

***THIS DOCUMENT IS FOR MAINTENANCE
PURPOSES ONLY AND IS NOT
RECOMMENDED FOR NEW DESIGNS***

15HSC Series

RADIATION HARD HIGH SPEED CMOS/SOS LOGIC

The 15HSC Series offer the combined benefits of low power, high speed CMOS with the inherent latch up immunity, Single Event Upset (SEU) immunity and high level of radiation hardness of Silicon on Sapphire technology.

The 15HSC Series of CMOS/SOS devices are pin compatible with the 54LS Series and the 54HSC Series, but with a higher speed capability.

Further device types to those listed will be available shortly. Please contact GPS for further information.

DEVICE TYPES

15HSC138	3-Line to 8-Line Decoder/Multiplexer
15HSC163	Synchronous 4-Bit Counter

FEATURES

- Radiation Hard to 1.5 μ m CMOS/SOS Technology
- High SEU Immunity
- Latch Up Free
- Low Power CMOS/SOS Technology
- Plug In Replacement for 54/74LS, HC and HCT
- Dual In Line or Flatpack Packages
- High Speed (Toggle Rate 100MHz)

15HSC Series

DC CHARACTERISTICS AND RATINGS

Parameter	Min	Max	Units
Supply Voltage	-0.5	10	V
Input Voltage	-0.3	$V_{DD}+0.3$	V
Current Through Any Pin	-25	+25	mA
Operating Temperature	-55	125	°C
Storage Temperature	-65	150	°C

Note: Stresses above those listed may cause permanent damage to the device. This is a stress rating only and functional operation of the device at these conditions, or at any other condition above those indicated in the operations section of this specification, is not implied. Exposure to absolute maximum rating conditions for extended periods may affect device reliability.

Figure 1: Absolute Maximum Ratings

Symbol	Parameter	Conditions	Total dose radiation not exceeding 3×10^5 Rad(Si)			Units
			Min	Typ	Max	
V_{DD}	Supply Voltage	-	4.5	5.0	5.5	V
V_{IH1}	HST Input High Voltage	-	2.0	-	-	V
V_{IL1}	HST Input Low Voltage	-	-	-	0.8	V
V_{IH2}	HSC Input High Voltage	-	3.5	-	-	V
V_{IL2}	HSC Input Low Voltage	-	-	-	1.5	V
V_{OH}	Output High Voltage	$V_{IN} = V_{IH}$ or V_{IL} $I_{OH} = -20\mu A^*$	$V_{DD}-0.1$	-	-	V
		$I_{OH} = -6.0mA^*$	3.7	-	-	V
		$I_{OH} = -11.0mA$	2.5	-	-	V
V_{OL}	Output Low Voltage	$V_{IN} = V_{IH}$ or V_{IL} $I_{OL} = 20\mu A^*$	-	-	0.1	V
		$I_{OL} = 6.0mA^*$	-	-	0.2	V
		$I_{OL} = 9.0mA$	-	-	0.4	V
I_{IL}	Input Leakage Current	$V_{IN} = V_{DD}$ or V_{SS} All inputs	-	-	± 10	μA
I_{OL}	Output Leakage Current	$V_{OUT} = V_{DD}$ or V_{SS} Outputs disabled	-	-	50	μA
I_{DD}	Quiescent Current	$V_{IN} = V_{DD}$ Outputs unloaded	-	-	1	mA

$V_{DD} = 5V \pm 10\%$, over full operating temperature range.

* = Guaranteed but not tested.

Figure 2: Electrical Characteristics

15HSC138 : 3-Line to 8-Line Decoder/Multiplexer

Enable Inputs			Select Inputs			Outputs							
G ₁	GN _{2A}	GN _{2B}	C	B	A	Y ₀	Y ₁	Y ₂	Y ₃	Y ₄	Y ₅	Y ₆	Y ₇
X	H	X	X	X	X	H	H	H	H	H	H	H	H
X	X	H	X	X	X	H	H	H	H	H	H	H	H
L	X	X	X	X	X	H	H	H	H	H	H	H	H
H	L	L	L	L	L	L	H	H	H	H	H	H	H
H	L	L	L	L	H	H	L	H	H	H	H	H	H
H	L	L	L	H	L	H	H	L	H	H	H	H	H
H	L	L	L	H	H	H	H	H	L	H	H	H	H
H	L	L	H	L	L	H	H	H	H	L	H	H	H
H	L	L	H	L	H	H	H	H	H	H	L	H	H
H	L	L	H	H	L	H	H	H	H	H	H	L	H
H	L	L	H	H	H	H	H	H	H	H	H	H	L

H = high level, L = low level, X = irrelevant

Figure 3: Function Table

Symbol	Parameter	Spice Simulation	Max.	Units
t _{PLH}	Propagation delay. Address to Output	7.6	15	ns
t _{PHL}	Propagation delay. Address to Output.	7.4	15	ns
t _{PLH}	Propagation delay. G to Output	9.3	15	ns
t _{PHL}	Propagation delay. G to Output	8.8	15	ns

Figure 4: Switching Characteristics

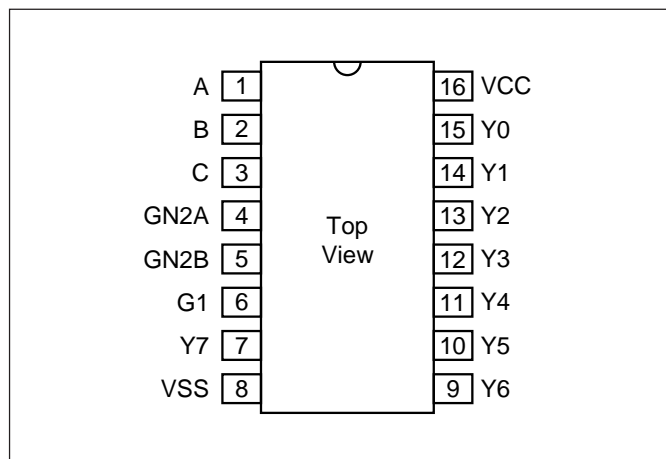

Figure 5: DIL Pin Out

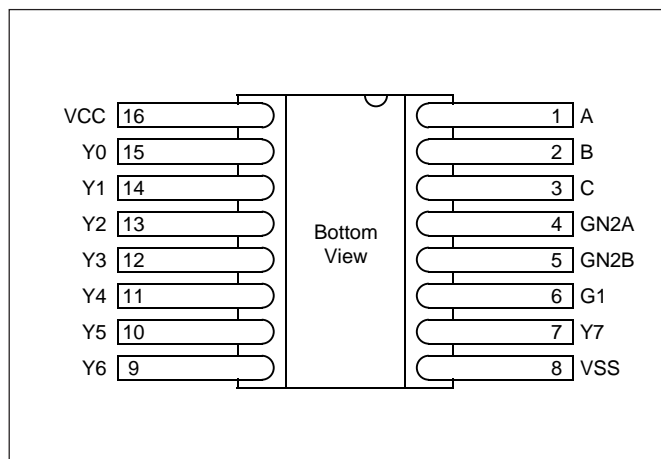

Figure 6: Flatpack Pin Out

15HSC Series

15HSC163 : 4-Bit Counter with Synchronous Clear

Symbol	Parameter	Spice Simulation	Max.	Units
t_{PLH}	Propagation delay. Clock to RCO	11.5	15	ns
t_{PHL}	Propagation delay. Clock to RCO	11.4	15	ns
t_{PLH}	Propagation delay. Clock to any Q	9.4	15	ns
t_{PHL}	Propagation delay. Clock to any Q	9.6	15	ns
t_{PLH}	Propagation delay. ENT to RCO	8.5	15	ns
t_{PHL}	Propagation delay. ENT to RCO	8.4	15	ns

Figure 7: Switching Characteristics

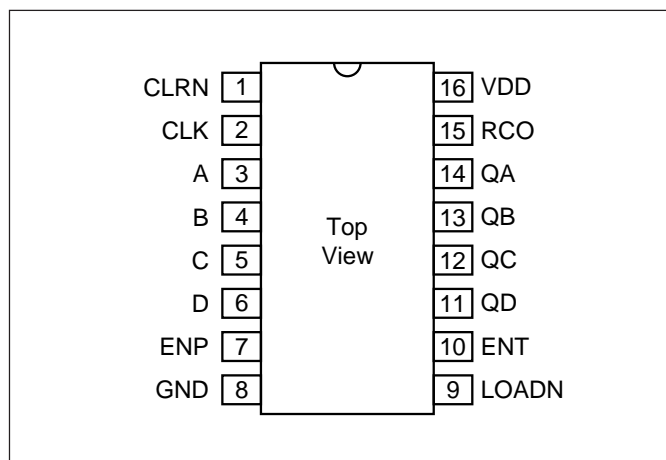

Figure 8: DIL Pin Out

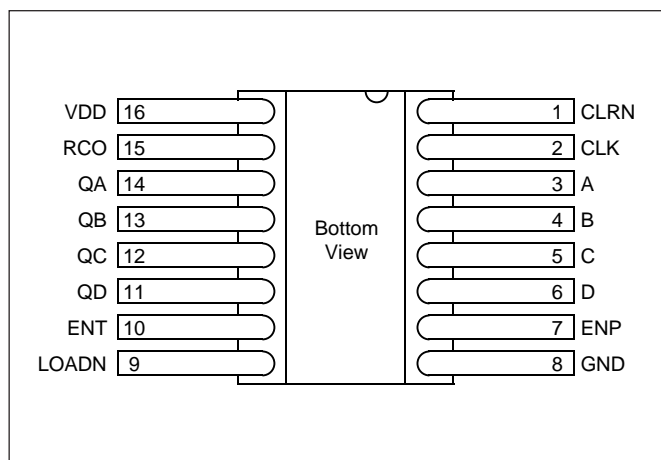

Figure 9: Flatpack Pin Out

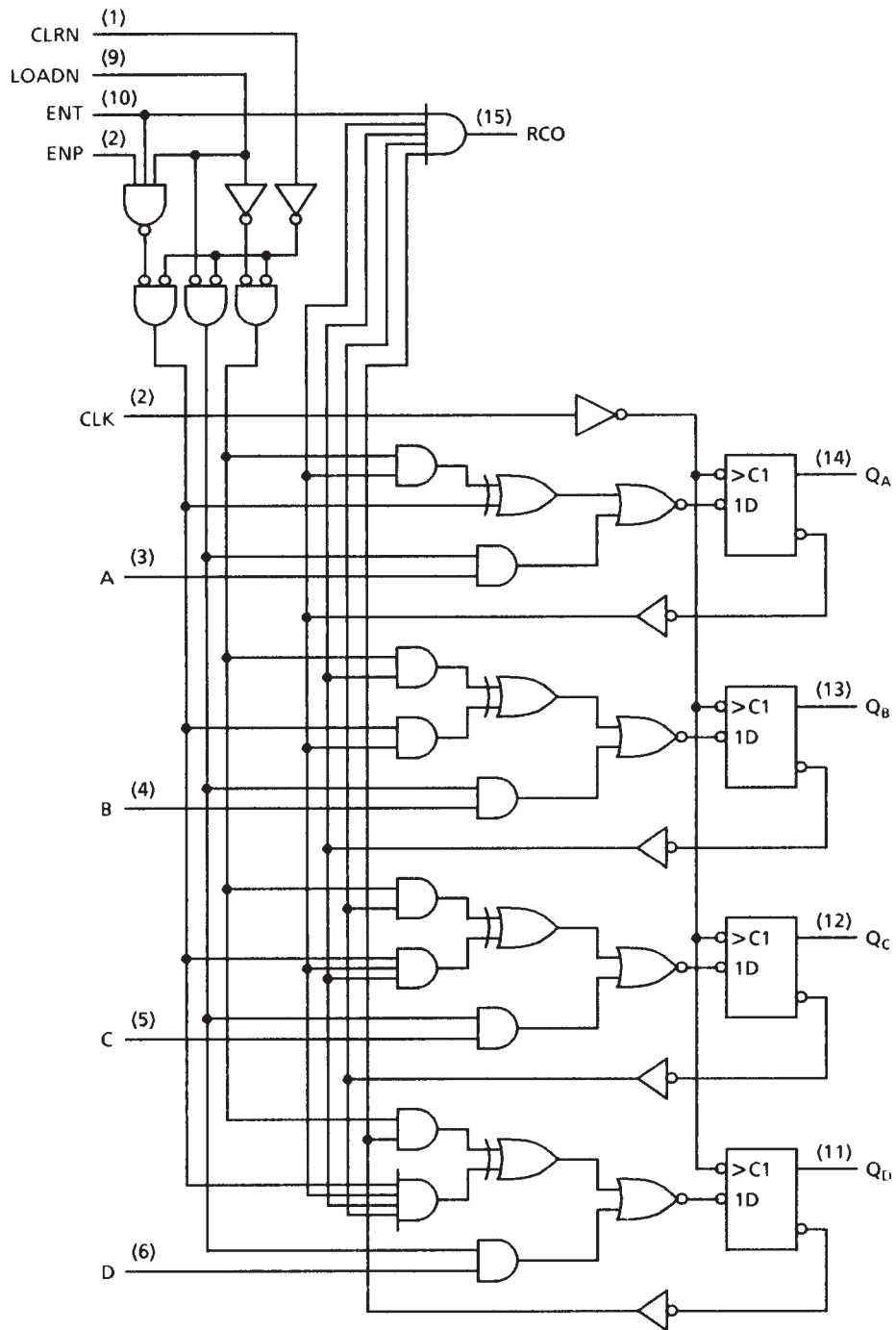

Figure 10: Logic Diagram

15HSC Series

Ref	Millimetres			Inches		
	Min.	Nom.	Max.	Min.	Nom.	Max.
A	-	-	5.60	-	-	0.220
A1	0.38	-	1.53	0.015	-	0.060
b	0.35	-	0.59	0.014	-	0.023
c	0.20	-	0.36	0.008	-	0.014
D	-	-	20.58	-	-	0.810
e	-	2.54 Typ.	-	-	0.100 Typ.	-
e1	-	7.62 Typ.	-	-	0.300 Typ.	-
H	4.45	-	5.38	0.175	-	0.212
Me	-	-	8.30	-	-	0.326
Z	-	-	1.27	-	-	0.050
W	-	-	1.53	-	-	0.060

XG402

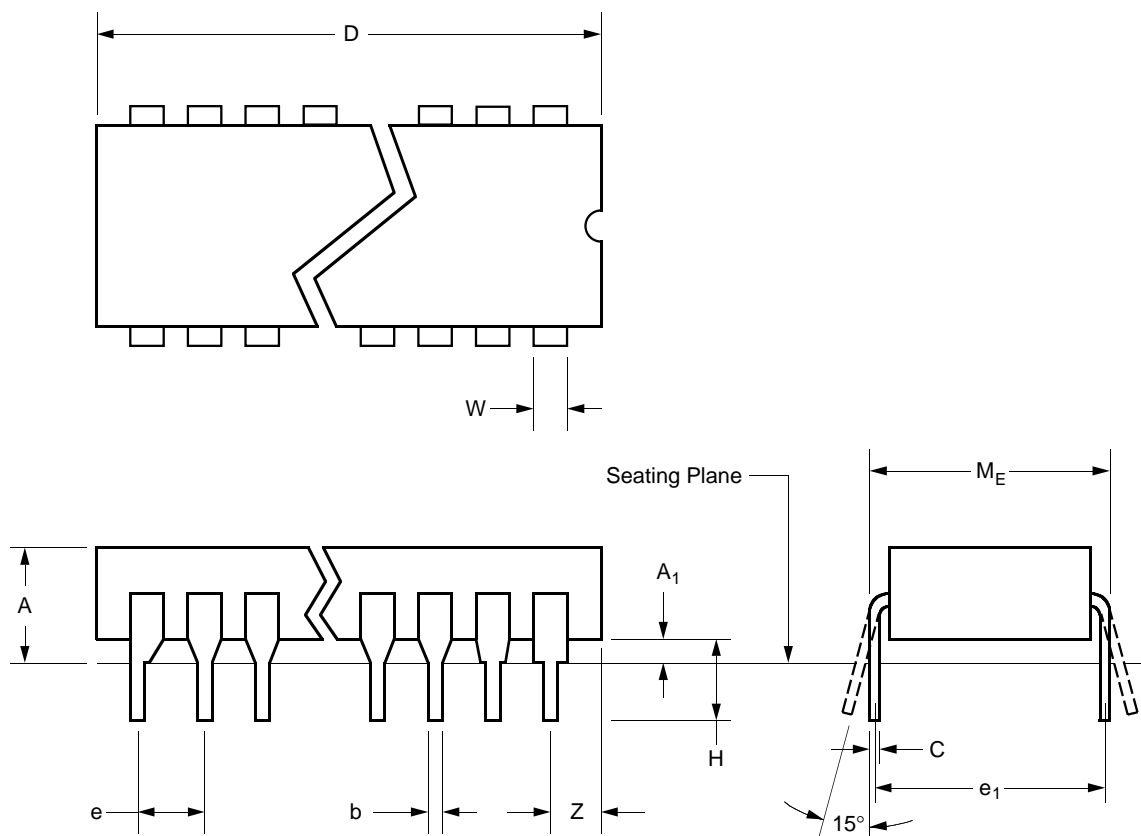

Figure 11: 16-Lead Ceramic DIL (Solder Seal) - Package Style C

Ref	Inches		
	Min.	Nom.	Max.
A	-	-	0.103
A1	0.026	-	-
b	0.015	-	0.019
c	0.004	-	0.006
D	0.392	-	0.408
e	-	0.050	-
L	0.250	-	0.305
M	0.264	-	0.276
E2	0.184	-	0.196
Z	0.005	-	-

XG534

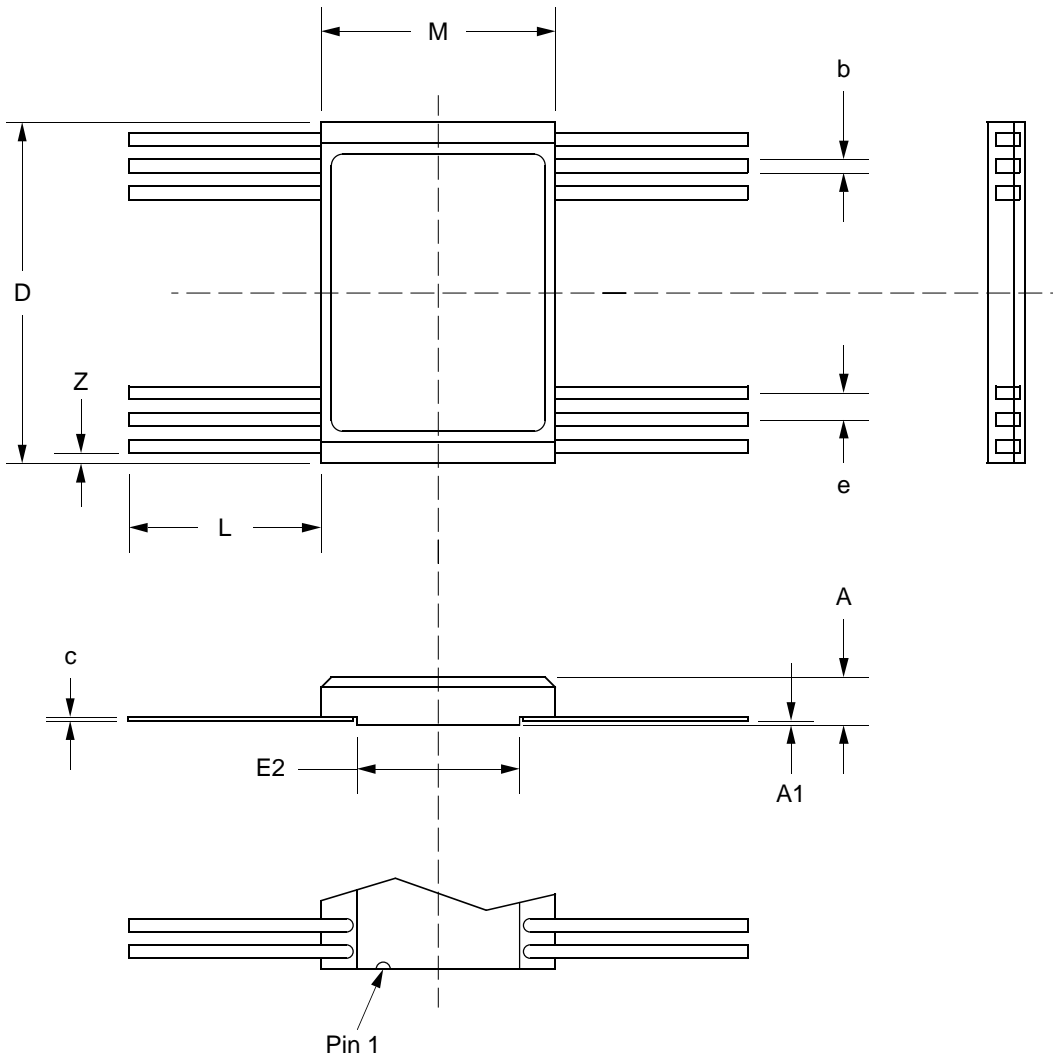

Figure 12: 16-Lead Bottom Braze Flatpack (Solder Seal) - Package Style F

15HSC Series

RADIATION TOLERANCE

Total Dose Radiation Testing

For product procured to guaranteed total dose radiation levels, each wafer lot will be approved when all sample devices from each lot pass the total dose radiation test.

The sample devices will be subjected to the total dose radiation level (Cobalt-60 Source), defined by the ordering code, and must continue to meet the electrical parameters specified in the data sheet. Electrical tests, pre and post irradiation, will be read and recorded.

GEC Plessey Semiconductors can provide radiation testing compliant with MIL-STD-883 test method 1019, Ionizing Radiation (Total Dose).

Total Dose (Function to specification)*	3x10 ⁵ Rad(Si)
Transient Upset (Stored data loss)	1x10 ¹¹ Rad(Si)/sec
Transient Upset (Survivability)	>1x10 ¹² Rad(Si)/sec
Neutron Hardness (Function to specification)	>1x10 ¹⁵ n/cm ²
Single Event Upset**	<1x10 ⁻¹⁰ Errors/bit day
Latch Up	Not possible

* Other total dose radiation levels available on request

** Worst case galactic cosmic ray upset - interplanetary/high altitude orbit

Figure 13: Radiation Hardness Parameters

ORDERING INFORMATION

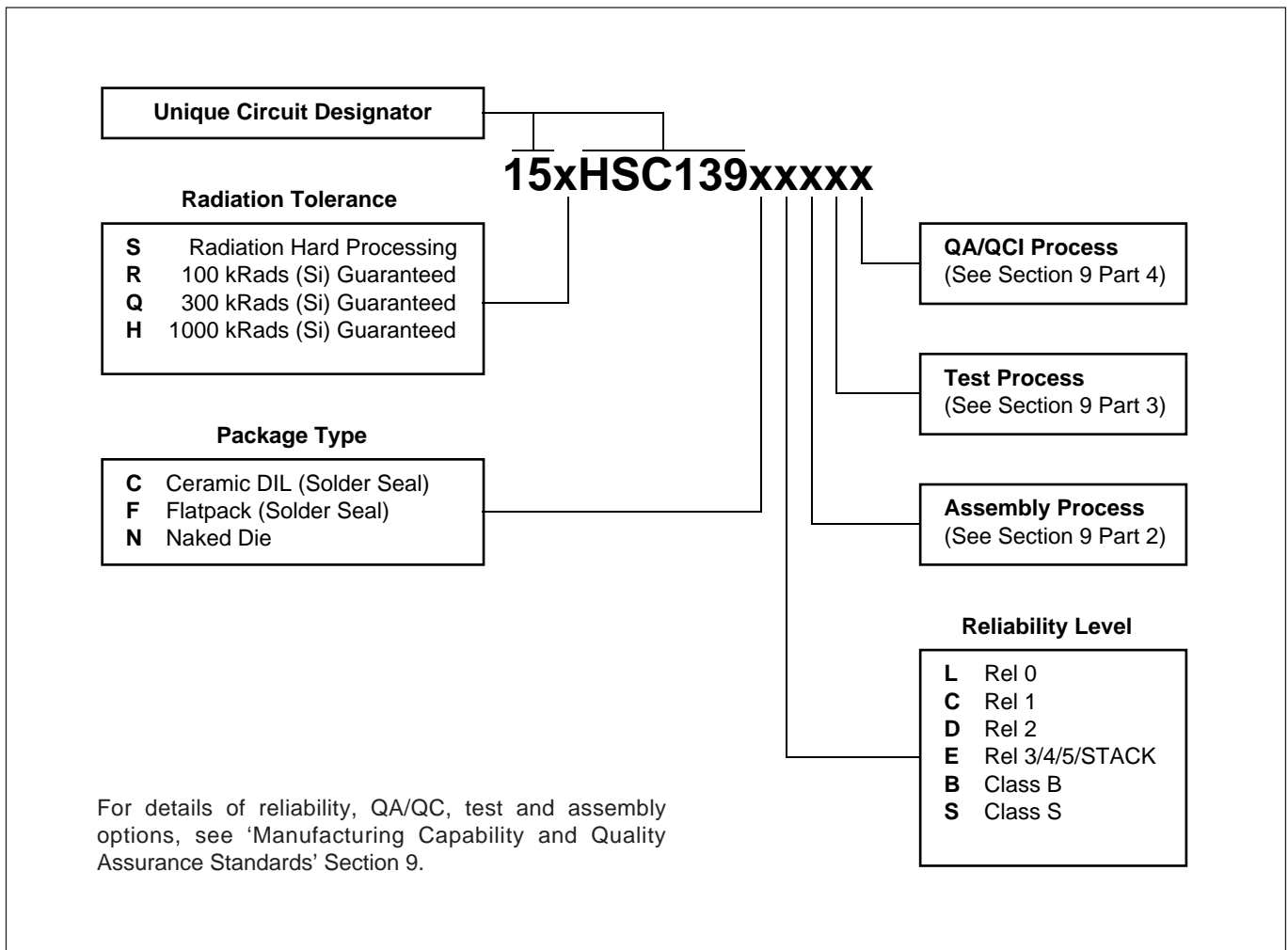



HEADQUARTERS OPERATIONS

GEC PLESSEY SEMICONDUCTORS

Cheney Manor, Swindon,
Wiltshire, SN2 2QW, United Kingdom.

Tel: (01793) 518000

Fax: (01793) 518411

GEC PLESSEY SEMICONDUCTORS

P.O. Box 660017,
1500 Green Hills Road, Scotts Valley,
California 95067-0017,
United States of America.

Tel: (408) 438 2900

Fax: (408) 438 5576

CUSTOMER SERVICE CENTRES

- **FRANCE & BENELUX** Les Ulis Cedex Tel: (1) 64 46 23 45 Fax: (1) 64 46 06 07
- **GERMANY** Munich Tel: (089) 3609 06-0 Fax: (089) 3609 06-55
- **ITALY** Milan Tel: (02) 66040867 Fax: (02) 66040993
- **JAPAN** Tokyo Tel: (03) 5276-5501 Fax: (03) 5276-5510
- **NORTH AMERICA** Scotts Valley, USA Tel: (408) 438 2900 Fax: (408) 438 7023
- **SOUTH EAST ASIA** Singapore Tel: (65) 3827708 Fax: (65) 3828872
- **SWEDEN** Stockholm Tel: 46 8 702 97 70 Fax: 46 8 640 47 36
- **TAIWAN, ROC** Taipei Tel: 886 2 5461260 Fax: 886 2 7190260
- **UK, EIRE, DENMARK, FINLAND & NORWAY** Swindon, UK Tel: (01793) 518527/518566
Fax: (01793) 518582

These are supported by Agents and Distributors in major countries world-wide.

© GEC Plessey Semiconductors 1995 Publication No. DS3593-2.3 April 1995

TECHNICAL DOCUMENTATION - NOT FOR RESALE. PRINTED IN UNITED KINGDOM.

This publication is issued to provide information only which (unless agreed by the Company in writing) may not be used, applied or reproduced for any purpose nor form part of any order or contract nor to be regarded as a representation relating to the products or services concerned. No warranty or guarantee express or implied is made regarding the capability, performance or suitability of any product or service. The Company reserves the right to alter without prior notice the specification, design or price of any product or service. Information concerning possible methods of use is provided as a guide only and does not constitute any guarantee that such methods of use will be satisfactory in a specific piece of equipment. It is the user's responsibility to fully determine the performance and suitability of any equipment using such information and to ensure that any publication or data used is up to date and has not been superseded. These products are not suitable for use in any medical products whose failure to perform may result in significant injury or death to the user. All products and materials are sold and services provided subject to the Company's conditions of sale, which are available on request.