

AK4601/..KD-3.5-V-P3.3-BK-HT

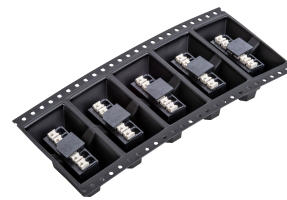

- Pin length 1.5 mm also available

Technical Data

Wire sizes		Insulating Material	
Solid min	0.2 mm ²	Material	PA
Solid max	1.5 mm ²	Flammability Class	UL 94 V-0
Stranded (flexible) min	0.2 mm ²	Temperatures	
Stranded (flexible) max	1.5 mm ²	Operating Temperature (without mech. load)	-40 °C - 105 °C
Stranded with Ferrule min	0.25 mm ²	Store Temperature	-40 °C - 105 °C
Stranded with Ferrule max	0.75 mm ²	Wave Soldering Process	
Dimensions		Soldering Temperature, recommended	260 °C
Stripped Length	10.0 mm	Peak Soldering Time, recommended	3-4 s
PCB Hole Diameter	1.2 mm	Reflow Process	
Materials		Soldering Temperature, recommended	217 - 245 °C
Solder Tab	Copper Alloy	Peak Soldering Time, recommended	60 s
Clamp Spring	Stainless Steel		

Colours

BLACK, RAL 9011

Colours according to RAL, there may be variations on colour due to production conditions.

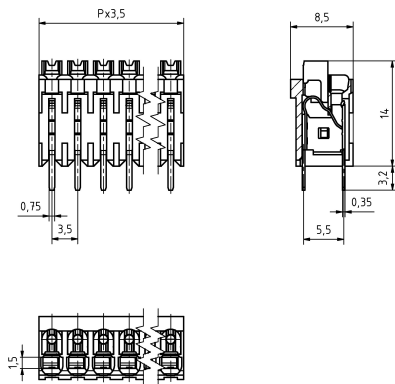

Order Data (Spacing 3.5 mm)

Poles	Width (mm)	Article Designation	Article Number	PU
2	7.00	AK4601/2KD-3.5-V-P3.3-BK-HT	54601020301R	150
3	10.50	AK4601/3KD-3.5-V-P3.3-BK-HT	54601030301R	150
4	14.00	AK4601/4KD-3.5-V-P3.3-BK-HT	54601040301R	150
...
10	35.00	AK4601/10KD-3.5-V-P3.3-BK-HT	54601100301R	150
11	38.50	AK4601/11KD-3.5-V-P3.3-BK-HT	54601110301R	150
12	42.00	AK4601/12KD-3.5-V-P3.3-BK-HT	54601120301R	150

Tape on Reel

Poles	Reel (RD/")	Width (R/mm)	Pitch (RP/mm)	Pieces (PCS)
2	13	44	20	150
3	13	44	20	150
4	13	44	20	150
...
10	13	72	20	150
11	13	72	20	150
12	13	72	20	150

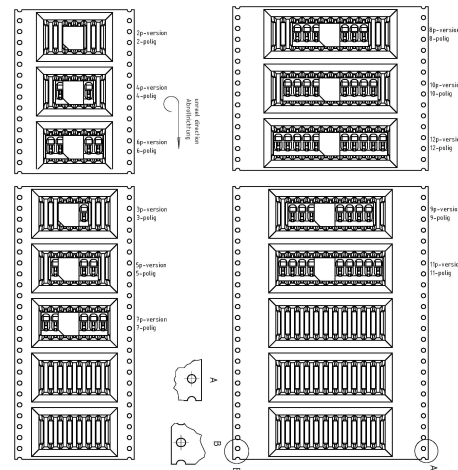

Ratings

UseGroup	C ^{RU} US			D'E	
	B	C	D		
Rated Voltage	300 V	-	300 V	250 V	
Rated Current	10 A	-	10 A	8 A	
Overvoltage Category				III	
Rated Wire Size				min	max
- solid	AWG 24-16	-	AWG 24-16	0.2 mm ²	1.5 mm ²
- stranded	AWG 24-16	-	AWG 24-16	0.2 mm ²	1.5 mm ²
Test Voltage	1.60 kV	-	1.60 kV	4.0 kV	
Pollution Degree				3	