

# IF DETECT ICs

TENTATIVE DATA

## FM IF DETECTOR IC FOR CELLULAR PHONE

### FEATURES

- 2 IF AMP circuits can limit a band width according to a usage.
- IF AMP has high performance carrier detection (RSSI).
- Low current consumption : 1.5mA (Typ.)
- Operating supply voltage range : 2.7~6.0V
- Small package (SSOP16 0.65mm pitch)

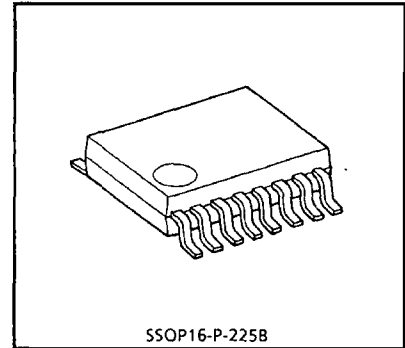

SSOP16-P-225B

Weight : 0.07g (Typ.)

### BLOCK DIAGRAM

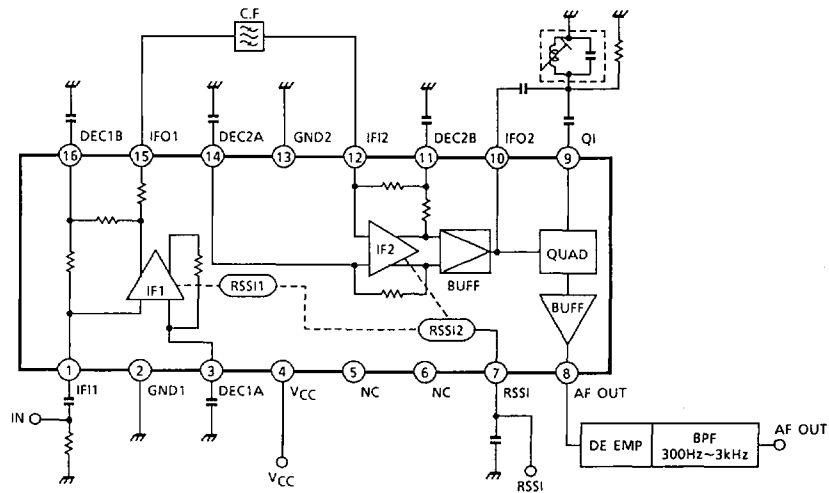

TA31133FN-1

# IF DETECT ICs

PIN FUNCTION (The values of resistor and capacitor are typical.)

PIN No.	PIN NAME	FUNCTION	INTERNAL EQUIVALENT CIRCUIT
1	IFI1	Input terminal for IF 1 AMP. Connect a capacitor for coupling.	
2	GND1	GND terminal for IF 1 AMP.	
3	EDC1A	Negative feedback (NF) terminal for IF 1 AMP. Connect GND through a capacitor.	
15	IFO1	Output terminal for IF 1 AMP. Output impedance is around 1.5kΩ. In case of connecting a ceramic filter, take note of matching.	
16	DEC1B	Connect a coupling capacitor for feedback loop of IF 1 AMP.	
4	VCC	The terminal for power supply.	
5	NC	NC terminal.	—
6	NC		
7	RSSI	Output terminal for RSSI. Output impedance is around 56kΩ. Connect a capacitor 1000pF for rectifying because of excepting AC element on this terminal.	
8	AF OUT	Output terminal for FM demodulator. Output impedance is around 1kΩ. Connect the De Emp. and BPF. circuit because of excepting Intermediate frequency element on this terminal.	
9	QI	Phase-shift input terminal for FM demodulator. Connect to the detector coil through a capacitor.	
10	IFO2	Output terminal for IF 2 AMP. Connect to the detector coil through a capacitor.	
11	DEC2B	Connect a coupling capacitor for feedback loop of IF 2 AMP.	
12	IFI2	Input terminal for IF 2 AMP. Connect a capacitor of coupling.	
13	GND2	GND terminal for IF 2 AMP.	
14	DEC2A	Negative feedback (NF) terminal for IF 2 AMP. Connect to GND through a capacitor.	

6

TA31133FN-2

# IF DETECT ICs

## DESCRIPTION

### 1. IF limiter and ceramic filter

This IC has double constitution of IF limiter AMP. It is available to limit a band width by sub-filter according to a usage. Connect a filter to serve an application.

Output of IF 1 limiter AMP. (pin 15) has the internal resistor (around  $1.3k\Omega$ ) for matching with filter.

And design the line on the board between IC and external parts as short as possible, because the gain of IF limiter is very high.

Especially design the line between pin 3, pin 14, pin 16, pin 11 and capacitors as short as possible.

### 2. FM detector

This IC uses a quadrature FM detection circuit.

Input to pin 9 the signal to shift the phase of IF AMP. Output in 90 degree with RCL resonance circuit. Tune with Tank circuit. (Recommended Tank circuit : 4164-102 (SUMIDA ELECTRIC CO., LTD.))

In case of connecting the discriminator, connect as follows.

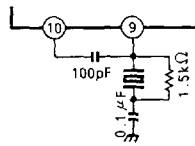

Ceramic discriminator  
CDB450C21 (MURATA MFG. CO., LTD.)

### 3. Demodulator output

The demodulated signal is outputted from pin 8.

Connect de-emphasis circuit and BPF for excepting carrier element in the demodulator output (pin 8). On the TA31133FN test circuit, connect the de-emphasis (0dB (at 1kHz),  $-6dB/OCT.$ ) and BPF (300Hz~3kHz).

### 4. RSSI circuit

Available to detect the input signal level with DC voltage on RSSI circuit.

RSSI is kept the linear characteristic period between  $20dB\mu V$  and  $100dB\mu V$  of IF input level.

The temperature regulation is very small.

The RSSI output is DC voltage on pin 7.

To change the output voltage is to connect a resistance between pin 7 and GND (in parallel with internal resistance  $56k\Omega$ ). But this IC has no temperature regulation internally, so note temperature regulation of external resistance. (In case of changing RSSI output voltage, connect the resistance to have small temperature regulation.)

TA31133FN-3

# IF DETECT ICs

## MAXIMUM RATINGS (Ta = 25°C)

CHARACTERISTIC	SYMBOL	RATING	UNIT
Supply Voltage	V <sub>CC</sub>	6.5	V
Power Dissipation	P <sub>D</sub>	560	mW
Operating Temperature	T <sub>opr</sub>	-30~85	°C
Storage Temperature	T <sub>stg</sub>	-55~150	°C

## ELECTRICAL CHARACTERISTICS

(Unless otherwise specified, Ta = 25°C, V<sub>CC</sub> = 3.5V, f<sub>I</sub>(IF) = 450kHz, Δf = ±1.75kHz, f<sub>MOD</sub> = 1kHz)

CHARACTERISTIC	SYMBOL	TEST CIRCUIT	TEST CONDITION	MIN.	TYP.	MAX.	UNIT
Quiescent Current Consumption	I <sub>CCQ</sub>	—	—	0.9	1.5	2.6	mA
Pre-stage IF AMP. Gain	GIF1	—	—	—	66	—	dB
Following-stage IF AMP. Gain	GIF2	—	—	—	52	—	dB
Level Detection Output 1	VRSSI1	—	V <sub>I</sub> (IF) = 20dBμV	0.3	0.42	0.6	V
Level Detection Output 2	VRSSI2	—	V <sub>I</sub> (IF) = 100dBμV	1.8	2.1	2.5	V
Demodulation Output	V <sub>OD</sub>	—	V <sub>I</sub> (IF) = 60dBμV with De Emp. and BPF	32	45	56	mV <sub>rms</sub>
Signal To Noise Ratio 1	S/N-1	—	V <sub>I</sub> (IF) = 20dBμV	22	25	—	dB
Signal To Noise Ratio 2	S/N-2	—	V <sub>I</sub> (IF) = 70dBμV	50	55	—	dB
AM Rejection Ratio	AMR	—	V <sub>I</sub> (IF) = 70dBμV, AM = 30%	—	45	—	dB

## TEST CIRCUIT

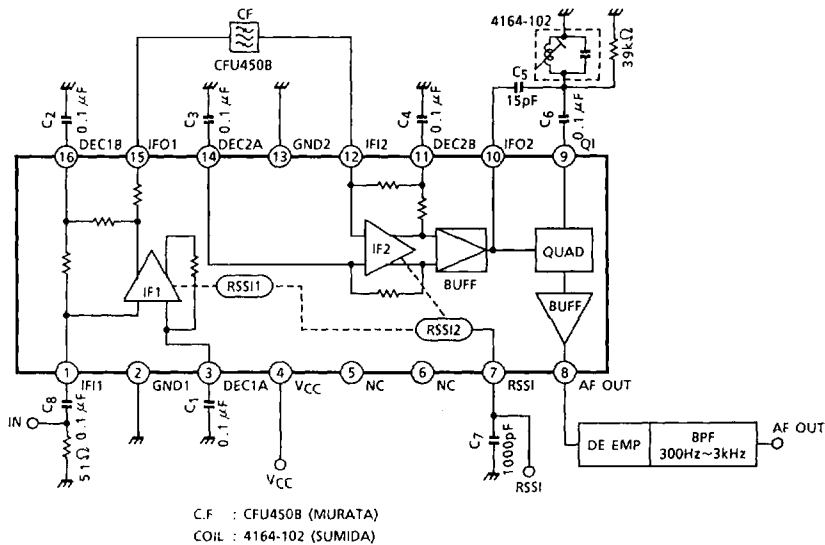

TA31133FN-4

# IF DETECT ICs

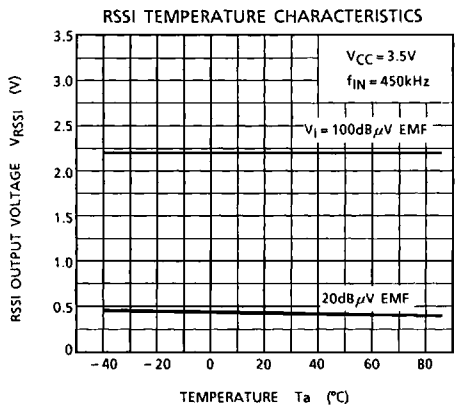
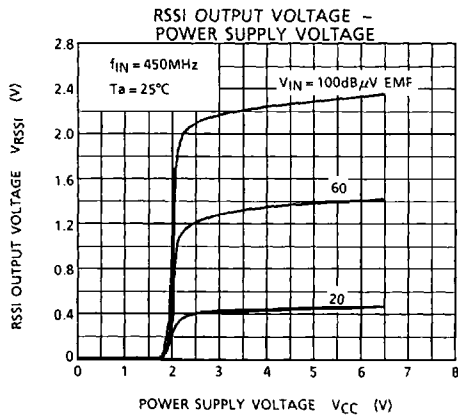
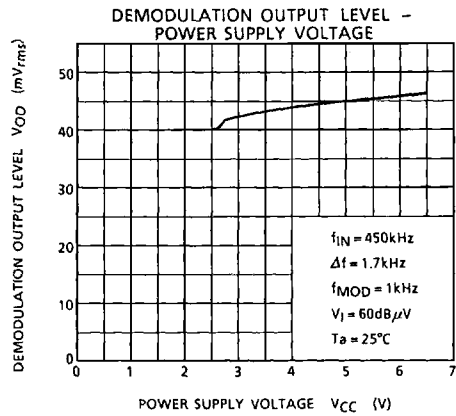
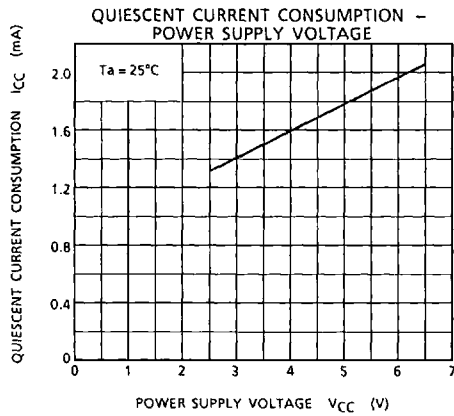
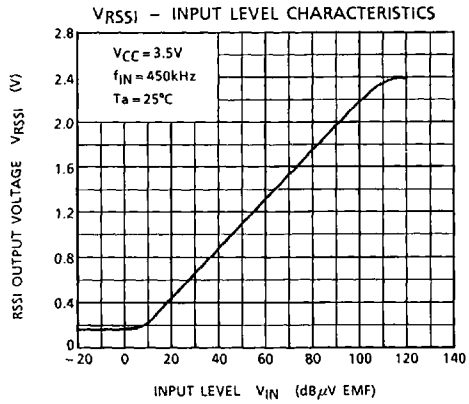
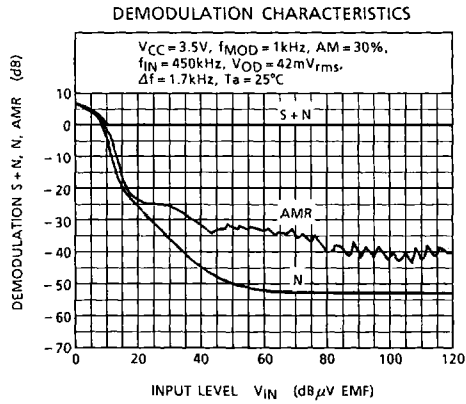

TA31133FN-5

# IF DETECT ICs

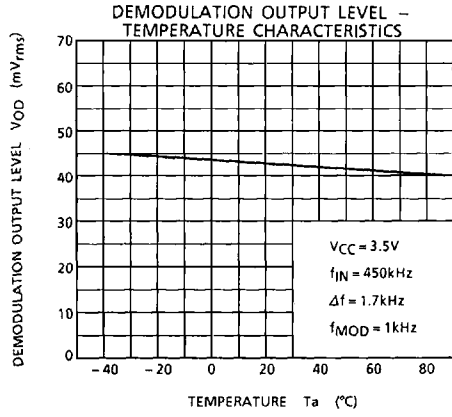

6

TA31133FN-6

331