

54AC11109, 74AC11109 DUAL J- \bar{K} POSITIVE-EDGE-TRIGGERED FLIP-FLOPS WITH CLEAR AND PRESET

SCAS450 – MARCH 1987 – REVISED APRIL 1993

- Flow-Through Architecture Optimizes PCB Layout
- Center-Pin V_{CC} and GND Configurations Minimize High-Speed Switching Noise
- EPIC™ (Enhanced-Performance Implanted CMOS) 1- μ m Process
- 500-mA Typical Latch-Up Immunity at 125°C
- ESD Protection Exceeds 2000 V, MIL STD-883C Method 3015
- Package Options Include Plastic Small-Outline Packages, Ceramic Chip Carriers, and Standard Plastic and Ceramic 300-mil DIPs

description

These devices contain two independent J- \bar{K} positive-edge-triggered flip-flops. A low level at the preset (\overline{PRE}) or clear (\overline{CLR}) inputs sets or resets the outputs regardless of the levels of the other inputs. When preset and clear are inactive (high), data at the J and \bar{K} inputs meeting the setup time requirements are transferred to the outputs on the positive-going edge of the clock pulse. Clock triggering occurs at a voltage level and is not directly related to the rise time of the clock pulse. Following the hold time interval, data at the J and \bar{K} inputs may be changed without affecting the levels at the outputs. These versatile flip-flops can perform as toggle flip-flops by grounding \bar{K} and tying J high. They also can perform as D-type flip-flops by tying the J and \bar{K} inputs together.

The 54AC11109 is characterized for operation over the full military temperature range of -55°C to 125°C . The 74AC11109 is characterized for operation from -40°C to 85°C .

54AC11109 . . . J PACKAGE
74AC11109 . . . D OR N PACKAGE
(TOP VIEW)

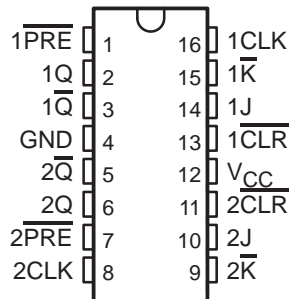

54AC11109 . . . FK PACKAGE
(TOP VIEW)

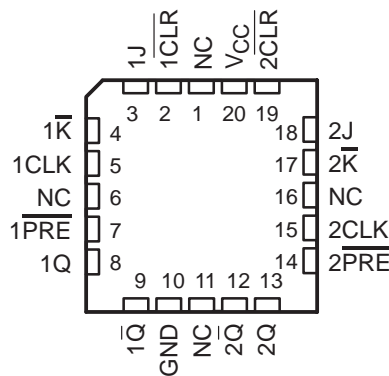

NC – No internal connection

FUNCTION TABLE
(each gate)

INPUTS					OUTPUTS	
\overline{PRE}	\overline{CLR}	CLK	J	\bar{K}	Q	\bar{Q}
L	H	X	X	X	H	L
H	L	X	X	X	L	H
L	L	X	X	X	H [†]	H [†]
H	H	↑	L	L	L	H
H	H	↑	H	L	Toggle	
H	H	↑	L	H	Q_0	\bar{Q}_0
H	H	↑	H	H	H	L
H	H	L	X	X	Q_0	\bar{Q}_0

[†] This configuration is nonstable; that is, it will not persist when either \overline{PRE} or \overline{CLR} returns to its inactive (high) level.

EPIC is a trademark of Texas Instruments Incorporated.

PRODUCTION DATA information is current as of publication date. Products conform to specifications per the terms of Texas Instruments standard warranty. Production processing does not necessarily include testing of all parameters.



POST OFFICE BOX 655303 • DALLAS, TEXAS 75265

Copyright © 1993, Texas Instruments Incorporated

54AC11109, 74AC11109 DUAL J-K POSITIVE-EDGE-TRIGGERED FLIP-FLOPS WITH CLEAR AND PRESET

SCAS450 – MARCH 1987 – REVISED APRIL 1993

logic symbol†

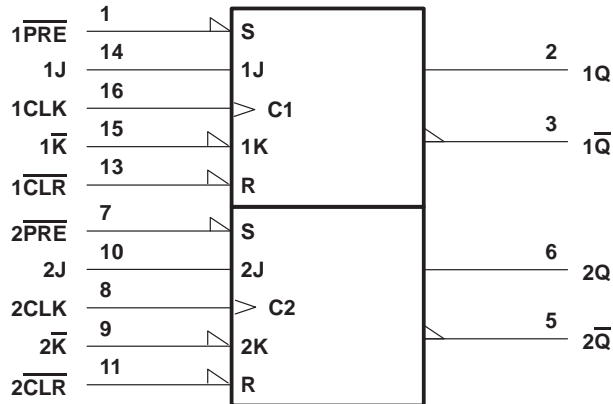

† This symbol is in accordance with ANSI/IEEE Std 91-1984 and IEC Publication 617-12.
Pin numbers shown are for the D, J, and N packages.

absolute maximum ratings over operating free-air temperature range (unless otherwise noted)‡

Supply voltage range, V_{CC}	-0.5 V to 7 V
Input voltage range, V_I (see Note 1)	-0.5 V to $V_{CC} + 0.5$ V
Output voltage range, V_O (see Note 1)	-0.5 V to $V_{CC} + 0.5$ V
Input clamp current, I_{IK} ($V_I < 0$ or $V_I > V_{CC}$)	± 20 mA
Output clamp current, I_{OK} ($V_O < 0$ or $V_O > V_{CC}$)	± 50 mA
Continuous output current, I_O ($V_O = 0$ to V_{CC})	± 50 mA
Continuous current through V_{CC} or GND	± 100 mA
Storage temperature range	-65°C to 150°C

‡ Stresses beyond those listed under "absolute maximum ratings" may cause permanent damage to the device. These are stress ratings only and functional operation of the device at these or any other conditions beyond those indicated under "recommended operating conditions" is not implied. Exposure to absolute-maximum-rated conditions for extended periods may affect device reliability.

NOTE 1: The input and output voltage ratings may be exceeded if the input and output current ratings are observed.

54AC11109, 74AC11109 DUAL J-K POSITIVE-EDGE-TRIGGERED FLIP-FLOPS WITH CLEAR AND PRESET

SCAS450 – MARCH 1987 – REVISED APRIL 1993

recommended operating conditions

		54AC11109			74AC11109			UNIT
		MIN	NOM	MAX	MIN	NOM	MAX	
V_{CC}	Supply voltage	3	5	5.5	3	5	5.5	V
V_{IH}	High-level input voltage	$V_{CC} = 3\text{ V}$	2.1		2.1			V
		$V_{CC} = 4.5\text{ V}$	3.15		3.15			
		$V_{CC} = 5.5\text{ V}$	3.85		3.85			
V_{IL}	Low-level input voltage	$V_{CC} = 3\text{ V}$		0.9		0.9		V
		$V_{CC} = 4.5\text{ V}$		1.35		1.35		
		$V_{CC} = 5.5\text{ V}$		1.65		1.65		
V_I	Input voltage	0		V_{CC}	0		V_{CC}	V
V_O	Output voltage	0		V_{CC}	0		V_{CC}	V
I_{OH}	High-level output current	$V_{CC} = 3\text{ V}$		-4		-4		mA
		$V_{CC} = 4.5\text{ V}$		-24		-24		
		$V_{CC} = 5.5\text{ V}$		-24		-24		
I_{OL}	Low-level output current	$V_{CC} = 3\text{ V}$		12		12		mA
		$V_{CC} = 4.5\text{ V}$		24		24		
		$V_{CC} = 5.5\text{ V}$		24		24		
$\Delta t/\Delta v$	Input transition rise or fall rate	0		10	0		10	ns/V
T_A	Operating free-air temperature	-55		125	-40		85	°C

electrical characteristics over recommended operating free-air temperature range (unless otherwise noted)

PARAMETER	TEST CONDITIONS	V_{CC}	$T_A = 25^\circ\text{C}$			54AC11109		74AC11109		UNIT
			MIN	TYP	MAX	MIN	MAX	MIN	MAX	
V_{OH}	$I_{OH} = -50\ \mu\text{A}$	3 V	2.9			2.9		2.9	V	
		4.5 V	4.4			4.4		4.4		
		5.5 V	5.4			5.4		5.4		
	$I_{OH} = -4\text{ mA}$	3 V	2.58			2.4		2.48		
		4.5 V	3.94			3.7		3.8		
		5.5 V	4.94			4.7		4.8		
		5.5 V				3.85				
$I_{OH} = -50\text{ mA}^\dagger$	5.5 V				3.85					
$I_{OH} = -75\text{ mA}^\dagger$	5.5 V					3.85				
V_{OL}	$I_{OL} = 50\ \mu\text{A}$	3 V			0.1		0.1	0.1	V	
		4.5 V			0.1		0.1	0.1		
		5.5 V			0.1		0.1	0.1		
	$I_{OL} = 12\text{ mA}$	3 V			0.36		0.5	0.44		
		4.5 V			0.36		0.5	0.44		
	$I_{OL} = 24\text{ mA}$	5.5 V			0.36		0.5	0.44		
		5.5 V					1.65			
$I_{OL} = 75\text{ mA}^\dagger$	5.5 V					1.65				
I_I	$V_I = V_{CC}$ or GND	5.5 V			± 0.1		± 1	± 1	μA	
I_{CC}	$V_I = V_{CC}$ or GND, $I_O = 0$	5.5 V			4		80	40	μA	
C_i	$V_I = V_{CC}$ or GND	5 V			3.5				pF	

[†] Not more than one output should be tested at a time, and the duration of the test should not exceed 10 ms.



54AC11109, 74AC11109
DUAL J-K POSITIVE-EDGE-TRIGGERED FLIP-FLOPS
WITH CLEAR AND PRESET

SCAS450 – MARCH 1987 – REVISED APRIL 1993

timing requirements, $V_{CC} = 3.3\text{ V} \pm 0.3\text{ V}$ (see Figure 1)

		$T_A = 25^\circ\text{C}$		54AC11109		74AC11109		UNIT
		MIN	MAX	MIN	MAX	MIN	MAX	
f_{clock}	Clock frequency	0	70	0	70	0	70	MHz
t_w	Pulse duration	$\overline{\text{PRE}}$ or $\overline{\text{CLR}}$ low		5		5		ns
		CLK low or CLK high		7.2		7.2		
t_{su}	Setup time before CLK \uparrow	Data high or low		5.5		5.5		ns
		$\overline{\text{PRE}}$ or $\overline{\text{CLR}}$ inactive		2.5		2.5		
t_h	Hold time after CLK \uparrow	0		0		0		ns

timing requirements, $V_{CC} = 5\text{ V} \pm 0.5\text{ V}$ (see Figure 1)

		$T_A = 25^\circ\text{C}$		54AC11109		74AC11109		UNIT
		MIN	MAX	MIN	MAX	MIN	MAX	
f_{clock}	Clock frequency	0	100	0	100	0	100	MHz
t_w	Pulse duration	$\overline{\text{PRE}}$ or $\overline{\text{CLR}}$ low		4		4		ns
		CLK low or CLK high		5		5		
t_{su}	Setup time, before CLK \uparrow	Data high or low		4.5		4.5	2.5	ns
		$\overline{\text{PRE}}$ or $\overline{\text{CLR}}$ inactive		2		2		
t_h	Hold time, after CLK \uparrow	0		0		0		ns

switching characteristics over recommended operating free-air temperature range, $V_{CC} = 3.3\text{ V} \pm 0.3\text{ V}$ (unless otherwise noted) (see Figure 1)

PARAMETER	FROM (INPUT)	TO (OUTPUT)	$T_A = 25^\circ\text{C}$			54AC11109		74AC11109		UNIT
			MIN	TYP	MAX	MIN	MAX	MIN	MAX	
f_{max}			70	100		70		70	MHz	
t_{PLH}	$\overline{\text{PRE}}$ or $\overline{\text{CLR}}$	Q or \overline{Q}	1.5	6.5	9	1.5	10.5	1.5	9.9	ns
t_{PHL}			1.5	8	12.6	1.5	14.4	1.5	13.7	
t_{PLH}	CLK	Q or \overline{Q}	1.5	8	11.4	1.5	13.5	1.5	12.7	ns
t_{PHL}			1.5	7.5	10.5	1.5	12.7	1.5	11.8	

switching characteristics over recommended operating free-air temperature range, $V_{CC} = 5\text{ V} \pm 0.5\text{ V}$ (unless otherwise noted) (see Figure 1)

PARAMETER	FROM (INPUT)	TO (OUTPUT)	$T_A = 25^\circ\text{C}$			54AC11109		74AC11109		UNIT
			MIN	TYP	MAX	MIN	MAX	MIN	MAX	
f_{max}			100	125		100		100	MHz	
t_{PLH}	$\overline{\text{PRE}}$ or $\overline{\text{CLR}}$	Q or \overline{Q}	1.5	4.5	6.5	1.5	7.6	1.5	7.1	ns
t_{PHL}			1.5	5	8.6	1.5	10.2	1.5	9.6	
t_{PLH}	CLK	Q or \overline{Q}	1.5	5.5	7.9	1.5	9.4	1.5	8.8	ns
t_{PHL}			1.5	5	7.3	1.5	8.6	1.5	8.1	

operating characteristics, $V_{CC} = 5\text{ V}$, $T_A = 25^\circ\text{C}$

PARAMETER	TEST CONDITIONS	TYP	UNIT
C_{pd}	Power dissipation capacitance per gate $C_L = 50\text{ pF}$, $f = 1\text{ MHz}$	32	pF



PARAMETER MEASUREMENT INFORMATION

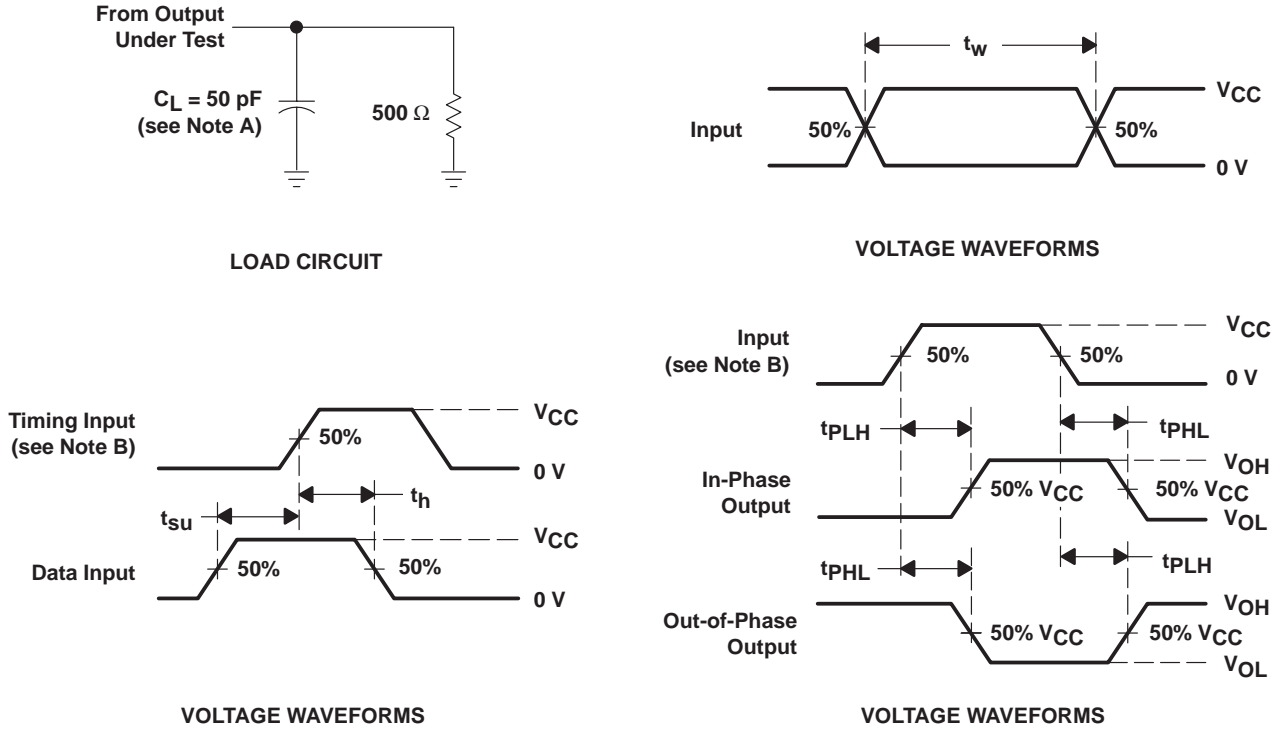

- NOTES: A. C_L includes probe and jig capacitance.
 B. All input pulses are supplied by generators having the following characteristics: $PRR \leq 10 \text{ MHz}$, $Z_O = 50 \Omega$, $t_r = 3 \text{ ns}$, $t_f = 3 \text{ ns}$.
 C. The outputs are measured one at a time with one input transition per measurement.

Figure 1. Load Circuit and Voltage Waveforms

IMPORTANT NOTICE

Texas Instruments and its subsidiaries (TI) reserve the right to make changes to their products or to discontinue any product or service without notice, and advise customers to obtain the latest version of relevant information to verify, before placing orders, that information being relied on is current and complete. All products are sold subject to the terms and conditions of sale supplied at the time of order acknowledgement, including those pertaining to warranty, patent infringement, and limitation of liability.

TI warrants performance of its semiconductor products to the specifications applicable at the time of sale in accordance with TI's standard warranty. Testing and other quality control techniques are utilized to the extent TI deems necessary to support this warranty. Specific testing of all parameters of each device is not necessarily performed, except those mandated by government requirements.

CERTAIN APPLICATIONS USING SEMICONDUCTOR PRODUCTS MAY INVOLVE POTENTIAL RISKS OF DEATH, PERSONAL INJURY, OR SEVERE PROPERTY OR ENVIRONMENTAL DAMAGE ("CRITICAL APPLICATIONS"). TI SEMICONDUCTOR PRODUCTS ARE NOT DESIGNED, AUTHORIZED, OR WARRANTED TO BE SUITABLE FOR USE IN LIFE-SUPPORT DEVICES OR SYSTEMS OR OTHER CRITICAL APPLICATIONS. INCLUSION OF TI PRODUCTS IN SUCH APPLICATIONS IS UNDERSTOOD TO BE FULLY AT THE CUSTOMER'S RISK.

In order to minimize risks associated with the customer's applications, adequate design and operating safeguards must be provided by the customer to minimize inherent or procedural hazards.

TI assumes no liability for applications assistance or customer product design. TI does not warrant or represent that any license, either express or implied, is granted under any patent right, copyright, mask work right, or other intellectual property right of TI covering or relating to any combination, machine, or process in which such semiconductor products or services might be or are used. TI's publication of information regarding any third party's products or services does not constitute TI's approval, warranty or endorsement thereof.