

NEW

MD5031T

DC-DC Converter Power IC

Control IC and Power MOSFET incorporated in SOP8 Package

MD5031T is a non-isolated, step down DC to DC converter power IC incorporating a main switch MOSFET and control circuit on a single chip.

Using surface mount SOP8 package, a circuit architecture has been achieved that requires very few external components. This has made it possible to realize a smaller and thinner power supply.



Standard Connection Diagram

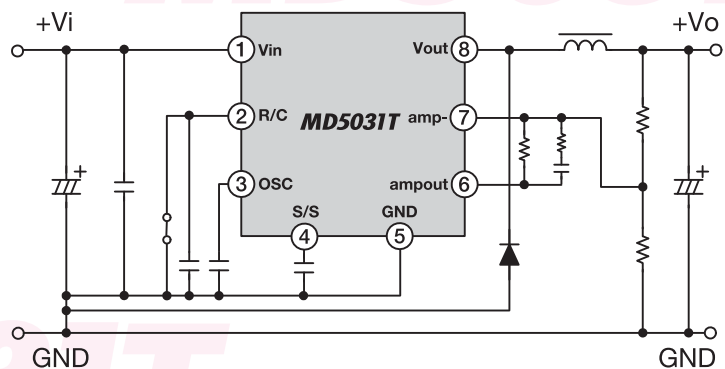

Features

- Input voltage range : 8V to 24V
- Output voltage range : 0.8V to 20V (adjustable by external resistors)
- Maximum output current : 1A (derating may be required depending on the condition of input and output voltages)
- Frequency 100kHz to 500kHz (adjustable by external capacitor)
- Built-in Power MOSFET
- Remote ON/OFF
- Over current protection
- Thermal shutdown

We are happy to provide circuit design support for safe use of our IC products.
Please consult our sales representatives or marketing sector.

Specifications

Recommended Operating Conditions

Item	Symbol	Recommendation	Units
Junction temperature	T _j	-40~125 ^{※6}	°C
Input voltage range	V _i ^{※3}	8~24	V
Output voltage setting range	V _o ^{※4}	0.8~20	V
Output current (ave)	I _{outave}	1 ^{※5}	A
Output current (peak)	I _{outpeak}	1.4 ^{※5}	A
Oscillation frequency	frq	100~500	kHz
Minimum ON time	T _{on min} ^{※7}	600	ns

※3 Input voltage at the time of power supply operation.

※4 Output voltage at the time of power supply operation.

※5 Refer to Calculation of junction temperature.

※6 In the case where the product is intended to be used for the equipment in which the long life is expected, we recommend to use at T_j = 100°C or less, as life of product may change depending on the use environment even used within the recommended operating conditions.

※7 ON time T_{on} is calculated by formula (V_o+V_F)/{(V_{in}+V_F-I_o×R_{on})×f} “f” represents oscillation frequency.

Calculation of junction temperature

Junction temperature can be calculated from power loss W_{IC}, thermal resistance θ_{jc} and case temperature T_c in actual operating conditions.

Calculation formula : T_j = T_c + (θ_{jc}×W_{IC})

W _{IC} = W _{circuit} - W _L - W _{SBD} - W _c	T _j junction temperature / θ _{jc} thermal resistance / W _{IC} IC loss
W _{circuit} = W _i - W _o	
W _i = V _i ×I _i	W _{IC} IC loss / W _{circuit} Circuit loss / W _L Choke loss
W _o = V _o ×I _o	W _{SBD} SBD loss / W _c Capacitor loss
W _L = I _o ² ×R _L	W _i Input capacitance / V _i Input voltage / I _i Input current
D = V _o /V _i	W _o Output capacitance / V _o Output voltage / I _o Output current
W _{SBD} = (1-D)×I _o ×V _F	R _L Resistance of choke / D Duty / V _F SBD forward voltage
W _c = (0.5×I _o) ² ×R _{c1} + (0.3×I _o /2√3) ² ×R _{c2}	R _{c1} ESR of input capacitor / R _{c2} ESR of output capacitor

Please make sure that junction temperature calculated from the above formula is within the range of “Recommended operating conditions”.

Caution : We do not guarantee to use the product beyond the Specifications. If you intend to use the product on conditions not described in the Specifications, please consult our Sales representatives in advance.

Electrical Characteristics

T_a=25°C

Item	Symbol	Condition	MIN	TYP	MAX	Units
Main MOSFET						
Drain-source breakdown voltage	V _{DSS}	I _D =5μA, V _{GS} =0V	26	—	—	V
Zero gate voltage drain current	I _{DSS}	V _{DS} =26V, V _{GS} =0V	—	—	10	μA
Static drain-source on-state resistance	R _{ON}	I _D =1A, V _{GS} =12V	—	700	850	mΩ
Source-drain diode forward voltage	V _{SD}	I _S =1A, V _{GS} =0V	—	—	1.5	V
Control IC						
Supply current (f=100kHz)	I _{CC_100}	V _{in} =8~24V	—	4	6	mA
Supply current (f=500kHz)	I _{CC_500}	V _{in} =8~24V	—	5	8	mA
Supply current at remote OFF	I _{CC_off}	V _{in} =8~24V	—	50	100	μA
Undervoltage lockout threshold (start)	V _{CC_start}	—	6.5	7.2	7.9	V
Undervoltage lockout hysteresis	V _{CC_hys}	—	0.4	0.5	0.6	V
Oscillation frequency1 (f=100kHz)	f _{osc1}	V _{in} =12V, C _{osc} =900pF	80	100	120	kHz
Oscillation frequency2 (f=500kHz)	f _{osc2}	V _{in} =12V, C _{osc} =120pF	400	500	600	kHz
Remote control ON input voltage	V _{R/C_ON}	V _{in} =12V	-0.2	—	0.5	V
Remote control OFF input voltage	V _{R/C_OFF}	V _{in} =12V	2	—	5.5	V
Remote control source current	I _{R/C}	V _{in} =8~24V	—	8	50	μA
Soft-start source current	I _{S/S}	V _{in} =12V	-3	-2	-1	μA
Error amplifier reference voltage	V _{amp}	V _{in} =8~24V	0.784	0.800	0.816	V
Threshold of over current limit	I _{th_OCL}	V _{in} =12V	1.41	—	—	A
Threshold of UVP	V _{th_UVP}	V _{in} =12V	V _{amp} ×74%	V _{amp} ×81.2%	V _{amp} ×90%	V
Thermal shutdown temperature	T _{TSD}	—	—	150	—	°C

Outline Dimensions

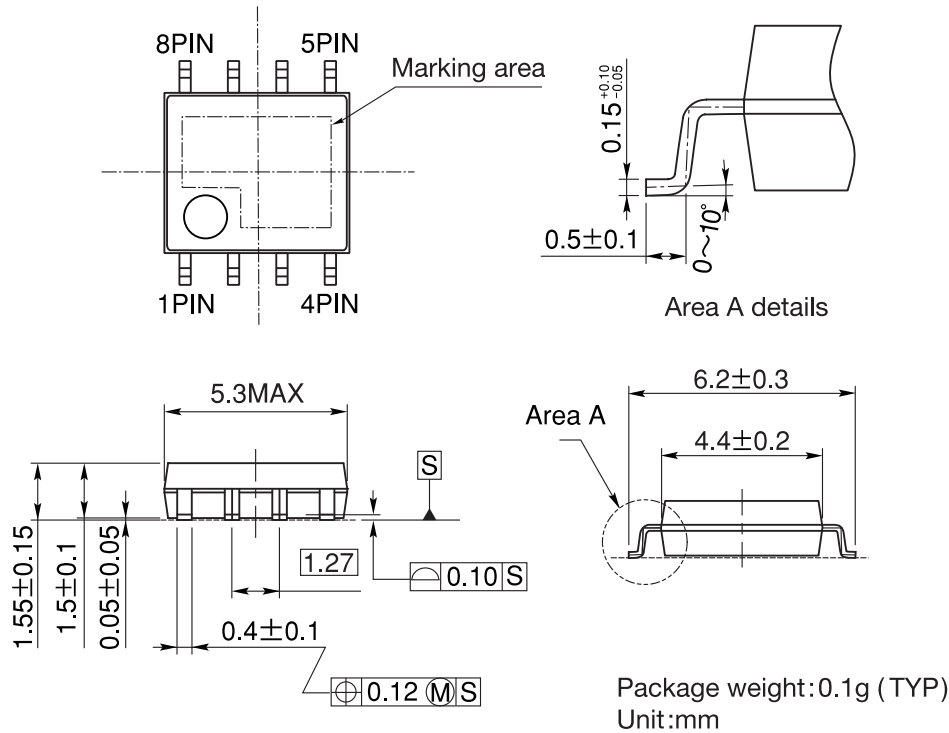

△ Although we are constantly making every effort to improve the quality and reliability of our products, there nevertheless remains a certain probability that the semiconductor products may occasionally fail or malfunction. Please take careful precautions against product failures or malfunctions to avoid any injuries, fire accidents or social loss by implementing safety designs such as redundancy designs, designs for fire spread prevention, and designs for preventing malfunctions.

△ Our semiconductor products listed in this document are not designed or manufactured to be used in devices or systems requiring extremely high levels of quality and reliability, or the failure or malfunction of which may directly threaten human lives or cause injury.

In the cases where the products are to be used in devices or systems for special applications or devices or systems for specialized applications shown below, always make sure to consult us in advance.

Special Applications

Transportation device (automotive, marine, etc), communication devices for core network, traffic signal devices, fire prevention/anticrime devices, various safety devices, medical devices, etc.

Specialized Applications

Nuclear power control systems, aircraft and aerospace devices, submarine relay devices, and devices and systems for preserving life, etc.

Even if it is not for a special or specialized application, when IC products are to be used for devices or systems that are desired to last for a long period under continuous operation, please make sure to consult us in advance.

* All specifications are subject to change without notice.

On Export Restrictions

● Restrictions List

This product corresponds the integrated circuit of Ministry Ordinance Article No. 6, Paragraph 7 of Separate Chart 1 of Exports of the Foreign Trade Control Law, but in a judgment on whether it applies or not, it was confirmed as not applying.

● Catch-All Restriction

This product is an article of Special Mention in Paragraph 16 of Separate Chart No.1 of the Exports of Foreign Trade Control Law and therefore comes under its jurisdiction.

February 2009

U.S.A.

Shindengen America, Inc. <www.shindengen.com/>

□ Head Office

2333 Waukegan Road Suite 170, Bannockburn, IL.60015 U.S.A.
Phone:+1-847-444-1363 Fax:+1-847-444-0654

□ Sales Office

21S. California St. Suite 408, Ventura, CA.93001 U.S.A.
Phone:+1-805-563-0823 Fax:+1-805-830-1706

Europe

Shindengen UK Ltd. <www.shindengen.co.uk/>

□ Head Office

Suite 4 Marquis House, 68 Great North Road,
Hatfield Hertfordshire, AL9 5ER U.K.
Phone:+44-1707-252550 Fax:+44-1707-252551

□ German Branch Office

Willstaetter Strasse 1, 40549, Dusseldorf, Germany
Phone:+49-211-4919680 Fax:+49-211-4986499

Asia

Shindengen Singapore PTE Ltd.

750D, Chai Chee Road, #05-01, Technopark @Chai Chee, Singapore 469004
Phone:+65-6445-0082 Fax:+65-6445-6089

Shindengen (H.K.) Co., Ltd.

□ Head Office

Suite 3206, 32/F, Tower 1, The Gateway, 25 Canton Road, TST,
Kowloon, Hong Kong
Phone:+852-2317-1884 Fax:+852-2314-8561

□ Taipei Branch

Room N1010, 10F, Chia-Hsin Bldg. 2 No. 96, SEC. 2, Chung
Shan N. Rd. Taipei, Taiwan R.O.C.
Phone:+886-2-2560-3990 Fax:+886-2-2560-3991

□ Shanghai Liaison Office

W504, Sun Plaza, No.88 Xianxia Road, Shanghai 200336, China
Phone:+86-21-6270-8000 Fax:+86-21-6270-0419

Shindengen Electric Mfg.Co., Ltd.

□ Seoul Office

Korea City Air-Terminal Bldg. 606, 159-6 Samsung-Dong
Kangnam-ku, Seoul, Korea
Phone:+82-2-551-1431 Fax:+82-2-551-1432



SHINDENGEN

www.shindengen.co.jp/

Shindengen Electric Mfg.Co., Ltd.

Head office

New-Ohtemachi Bldg., 2-1 Ohtemachi 2-chome, chiyoda-ku,
Tokyo 100-0004, Japan
Phone : +81-3-3279-4545, 4546, 4547
Fax : +81-3-3279-4519

Osaka Branch Office

Minami Senba Heart Bldg., 3-2, Minami Senba 2-chome,
Chuo-ku, Osaka City, Osaka 542-0081, Japan
Phone:+81-6-6264-7770 Fax:+81-6-6260-1222

Nagoya Branch Office

Nagoya-Daiichi Bldg., 1-19-24 Nishiki,
Naka-ku, Nagoya City, Aichi 460-0003, Japan
Phone:+81-52-221-1361 Fax:+81-52-201-4780