

2 M-WORD BY 72-BIT SYNCHRONOUS DYNAMIC RAM MODULE
BUFFERED TYPE
Description

The MC-452BA72 is a 2,097,152 words by 72 bits synchronous dynamic RAM module on which 9 pieces of 16 M SDRAM : μ PD4516821 are assembled.

This module provides high density and large quantities of memory in a small space without utilizing the surface-mounting technology on the printed circuit board.

Decoupling capacitors are mounted on power supply line for noise reduction.

Features

- 2,097,152 words by 72 bits organization
- Clock frequency and Burst cycle time

Family	Clock frequency (MAX.)	Burst cycle time (MIN.)	Power consumption (MAX.)	
			Active	Standby
★ MC-452BA72-A10	100 MHz	10 ns	5.29 W	64.8 mW (CMOS level input)
★ MC-452BA72-A12	83 MHz	12 ns	4.64 W	

- Fully Synchronous Dynamic RAM, with all signals referenced to a positive clock edge
- Pulsed interface
- Possible to assert random column address in every cycle
- Dual internal banks controlled by A11 (Bank Select)
- Programmable burst-length (1, 2, 4, 8 and Full Page)
- Programmable wrap sequence (Sequential/Interleave)
- Programmable /CAS latency (2, 3)
- Automatic precharge and controlled precharge
- CBR (Auto) refresh and self refresh
- ★ Single +3.3 +0.3/-0.15 V power supply
- LVTTTL compatible
- 2,048 refresh cycles/32 ms
- Burst termination by Burst Stop command and Precharge command
- 200-pin dual in-line memory module (Pin pitch = 1.27 mm)
- Buffered type

The information in this document is subject to change without notice.

Ordering Information

Part number	Clock frequency MHz (MAX.)	Package	Mounted devices
MC-452BA72F-A10	100 MHz	200-pin Dual In-line Memory Module (Socket Type)	9 pieces of 16M SDRAM :
MC-452BA72F-A12	83 MHz	Edge connector : Gold plated	μ PD4516821G5 (400 mil TSOP (II)) [Single side]

Pin Configuration

200-pin Dual In-line Memory Module Socket Type (Edge connector : Gold plated)

[MC-452BA72F]

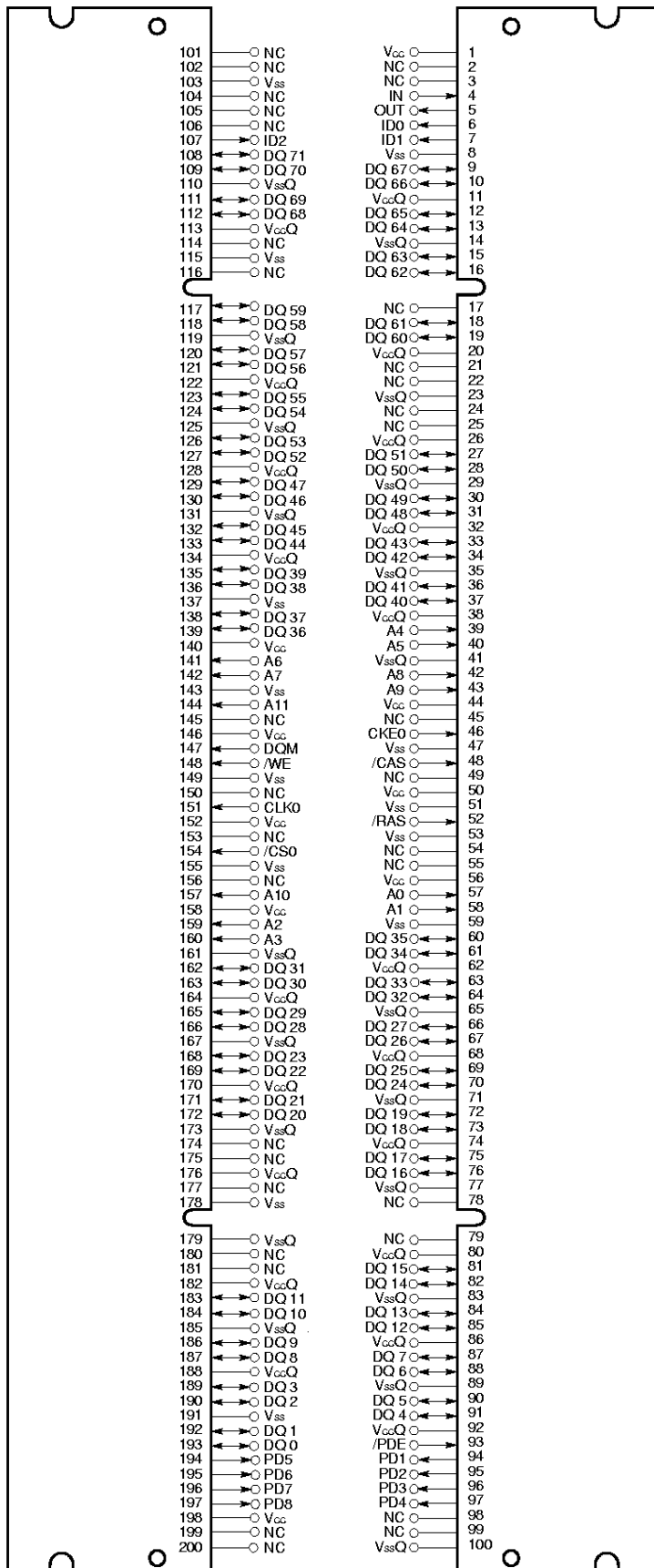

PD and ID Table

Pin name	Pin No.	Speed	
		10 ns	12 ns
PD1	94	H	H
PD2	95	L	L
PD3	96	L	L
PD4	97	H	H
PD5	194	H	L
PD6	195	L	H
PD7	196	H	H
PD8	197	H	H
ID0	6	H	H
ID1	7	L	L
ID2	107	L	L

Remark

PD : PD and ID must each be pulled up through a resistor to V_{cc} at the next higher level assembly. PDs will either be open (NC) or driven to V_{ss} via on-board buffer circuits.
 ID : IDs will either be open(NC) or connected directly to V_{ss} without a buffer.

A0 - A11 : Address Inputs

[Row : A0 - A10, Column : A0 - A8]

DQ0 - DQ71 : Data Inputs/Outputs

CLK0 : Clock Input

CKE0 : Clock Enable Input

/CS0 : Chip Select Input

/RAS : Row Address Strobe

/CAS : Column Address Strobe

/WE : Write Enable

DQM : DQ Mask Enable

/PDE : Presence Detect Enable

PD1 - PD8 : Presence Detect Pins

ID0 - ID2 : Identify Pins

IN, OUT : Unbuffered Physical Detect Input/Output (separate)

V_{cc} : Power Supply

V_{cc}Q : Power Supply for Data Input/Output

V_{ss} : Ground

V_{ss}Q : Ground for Data Input/Output

NC : No Connection

Block Diagram

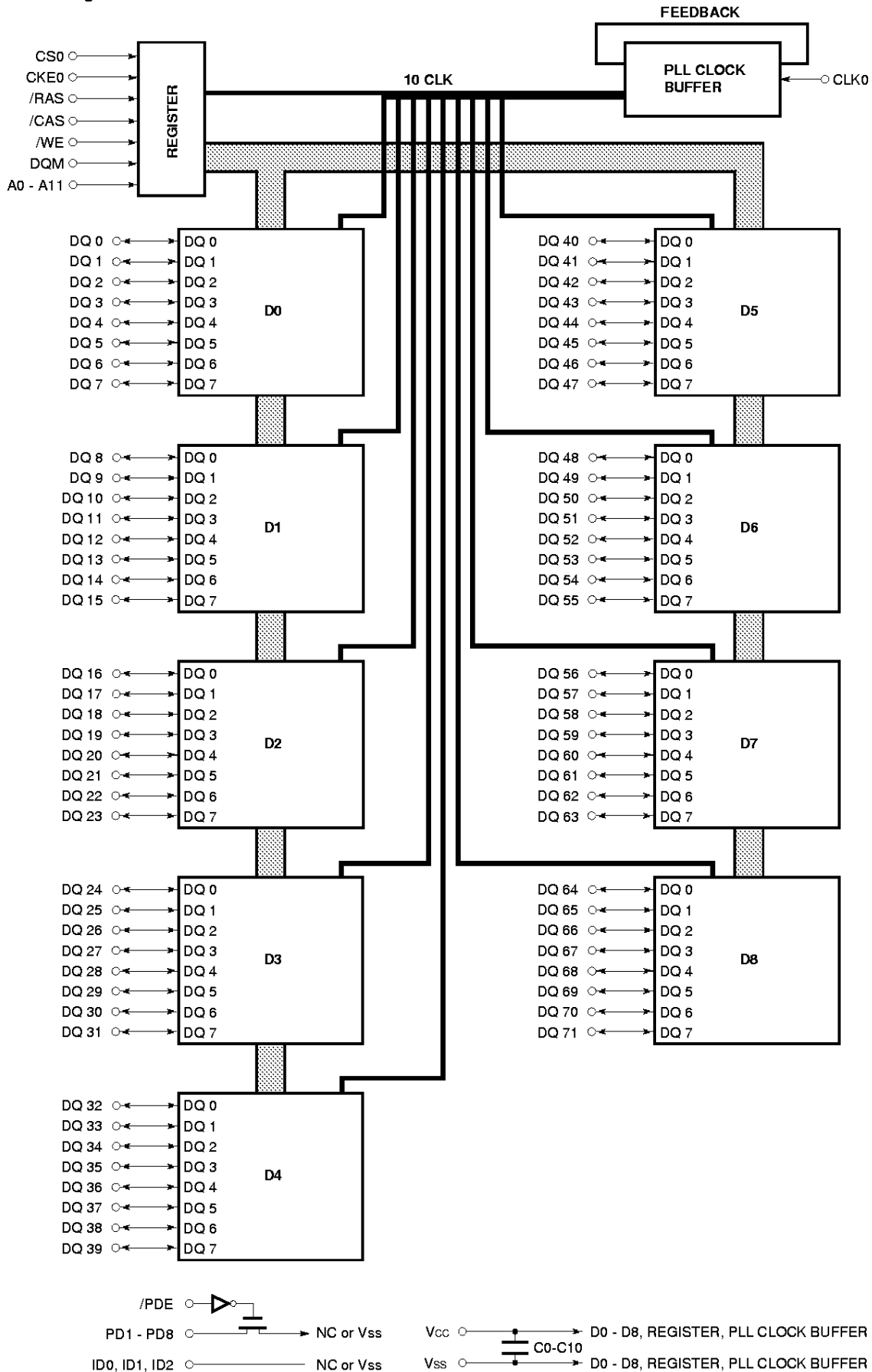

Remarks 1. A $10\Omega \pm 5\%$ resistor shall be wired in series with DQ0 - DQ71 near the card edge connector.
 All clock line outputs from the PLL CLOCK BUFFER shall be equal length.

Electrical Specifications (Preliminary)

- All voltages are referenced to V_{SS} (GND).
- After power up, wait more than 100 μ s and then, execute power on sequence and auto refresh before proper device operation is achieved.

Absolute Maximum Ratings

Parameter	Symbol	Condition	Rating	Unit
Voltage on power supply pin relative to GND	V _{CC}		-1.0 to +4.6	V
Voltage on input pin relative to GND	V _T		-1.0 to +4.6	V
Short circuit output current	I _o		50	mA
Power dissipation	P _D		11	W
Operating ambient temperature	T _A		0 to +70	°C
Storage temperature	T _{stg}		-55 to +125	°C

Caution Exposing the device to stress above those listed in Absolute Maximum Ratings could cause permanent damage. The device is not meant to be operated under conditions outside the limits described in the operational section of this specification. Exposure to Absolute Maximum Rating conditions for extended periods may affect device reliability.

Recommended Operating Conditions

Parameter	Symbol	Condition	MIN.	TYP.	MAX.	Unit
Supply voltage	V _{CC}		3.15	3.3	3.6	V
High level input voltage	V _{IH}		2.0		4.6	V
Low level input voltage	V _{IL}		-0.3		+0.8	V
Operating ambient temperature	T _A		0		70	°C

★

Capacitance (T_A = 25 °C, f = 1 MHz)

Parameter	Symbol	Test condition	MIN.	TYP.	MAX.	Unit
Input capacitance	C _{I1}	A0 - A11, CKE0, /CS0, /RAS, /CAS, /WE, DQM			15	pF
	C _{I2}	CLK0			8	
Data input/output capacitance	C _{I/O}	DQ0 - DQ71			10	pF

★ DC Characteristics (Recommended Operating Conditions unless otherwise noted)

Parameter	Symbol	Test condition		MIN.	MAX.	Unit	Notes
Operating current	I _{CC1}	Burst length = 1 t _{RC} ≥ t _{RC(MIN)} , I _O = 0 mA	/CAS latency = 2		1,020	mA	1
			/CAS latency = 3		1,065		
Precharge standby current in power down mode	I _{CC2P}	CKE ≤ V _{IL(MAX)} , t _{CK} = 15 ns			27	mA	2
	I _{CC2PS}	CKE ≤ V _{IL(MAX)} , t _{CK} = ∞			18		
Precharge standby current in non power down mode	I _{CC2N}	CKE ≥ V _{IH(MIN)} , t _{CK} = 15 ns, /CS ≥ V _{IH(MIN)} , Input signals are changed one time during 30 ns.			225	mA	2
	I _{CC2NS}	CKE ≥ V _{IH(MIN)} , t _{CK} = ∞ Input signals are stable.			54		
Active standby current in power down mode	I _{CC3P}	CKE ≤ V _{IL(MAX)} , t _{CK} = 15 ns			27	mA	2
	I _{CC3PS}	CKE ≤ V _{IL(MAX)} , t _{CK} = ∞			18		
Active standby current in non power down mode	I _{CC3N}	CKE ≥ V _{IH(MIN)} , t _{CK} = 15 ns, /CS ≥ V _{IH(MIN)} , Input signals are changed one time during 30 ns.			252	mA	2
	I _{CC3NS}	CKE ≥ V _{IH(MIN)} , t _{CK} = ∞ Input signals are stable.			90		
Operating current (Burst mode)	I _{CC4}	t _{CK} ≥ t _{CK(MIN)} I _O = 0 mA	/CAS latency = 2	-A10	1,200	mA	3
				-A12	1,020		
			/CAS latency = 3	-A10	1,470		
				-A12	1,290		
Refresh current	I _{CC5}	t _{RC} ≥ t _{RC(MIN)}			1,110	mA	4
Self refresh current	I _{CC6}	CKE ≤ 0.2 V			18	mA	2
Input leakage current	I _{I(L)}	V _I = 0 to 3.6 V, All other pins not under test = 0 V		-10	+10	μA	
Output leakage current	I _{O(L)}	D _{OUT} is disabled, V _O = 0 to 3.6 V		-10	+10	μA	
High level output voltage	V _{OH}	I _O = -2.0 mA		2.4		V	
Low level output voltage	V _{OL}	I _O = +2.0 mA			0.4	V	

- Notes**
- I_{CC1} depends on output loading and cycle rates. Specified values are obtained with the output open. In addition to this, I_{CC1} is measured on condition that addresses are changed only one time during t_{CK(MIN)}.
 - V_{CC} - 0.2 V ≤ V_{IH(CLK)} ≤ V_{IH(MAX)}, 0 V ≤ V_{IL} ≤ 0.2 V
 - I_{CC4} depends on output loading and cycle rates. Specified values are obtained with the output open. In addition to this, I_{CC4} is measured on condition that addresses are changed only one time during t_{CK(MIN)}.
 - I_{CC5} is measured on condition that addresses are changed only one time during t_{CK(MIN)}.

AC Characteristics (Recommended Operating Conditions unless otherwise noted)

AC Characteristics Test Conditions

- AC measurements assume $t_r = 1$ ns.
- Reference level for measuring timing of input signals is 1.4 V. Transition times are measured between V_{IH} and V_{IL} .
- If t_r is longer than 1 ns, reference level for measuring timing of input signals is $V_{IH(MIN)}$ and $V_{IL(MAX)}$.
- An access time is measured at 1.4 V.

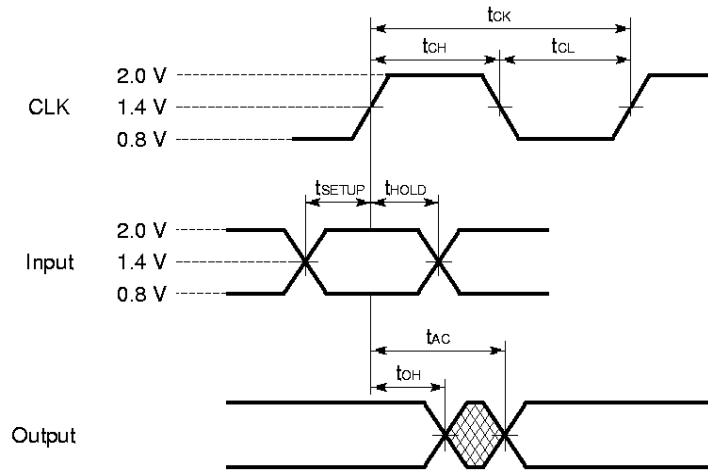

Synchronous Characteristics

Parameter	Symbol	-A10		-A12		Unit	Note	
		MIN.	MAX.	MIN.	MAX.			
Clock cycle time	/CAS latency = 3	t _{CK3}	10	(100 MHz)	12	(83 MHz)	ns	
	/CAS latency = 2	t _{CK2}	15	(67 MHz)	18	(55 MHz)	ns	
Access time from CLK	/CAS latency = 3	t _{AC3}		8.5		9.5	ns	1
	/CAS latency = 2	t _{AC2}		9.5		12.5	ns	1
Input CLK duty cycle			40	60	40	60	%	
Data-out hold time	t _{OH}		3.5		3.5		ns	1
Data-out low-impedance time	t _{LZ}		0		0		ns	
Data-out high-impedance time	t _{HZ}		3.5	8	3.5	8	ns	
Data-in setup time	t _{DS}		3.0		3.5		ns	
Data-in hold time	t _{DH}		1.5		2.0		ns	
Address setup time	t _{AS}		3.5		3.5		ns	
Address hold time	t _{AH}		0.5		0.5		ns	
CKE setup time	t _{CKS}		3.5		3.5		ns	
CKE hold time	t _{CKH}		0.5		0.5		ns	
CKE setup time (Power down exit)	t _{CKSP}		3.0		3.5		ns	
Command (/CS0, /RAS, /CAS, /WE, DQM) setup time	t _{CMS}		3.5		3.5		ns	
Command (/CS0, /RAS, /CAS, /WE, DQM) hold time	t _{CMH}		0.5		0.5		ns	

Note 1. Output load

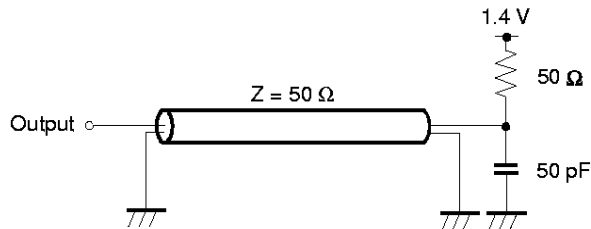

Asynchronous Characteristics

Parameter	Symbol	-A10		-A12		Unit	Note
		MIN.	MAX.	MIN.	MAX.		
REF to REF/ACT command period	t _{RC}	100		102		ns	
ACT to PRE command period	t _{RAS}	60	120,000	72	120,000	ns	
PRE to ACT command period	t _{RP}	30		30		ns	
Delay time ACT to READ/WRITE command	t _{RCD}	30		30		ns	
ACT(one) to ACT(another) command period	t _{RRD}	20		24		ns	
Data-in to PRE command period	t _{DPL}	-1CLK + 10		-1CLK + 12		ns	
Data-in to ACT(REF) command period (Auto precharge)	/CAS latency = 3 t _{DAL3}	1CLK + 30		1CLK + 30		ns	
	/CAS latency = 2 t _{DAL2}	30		30		ns	
Mode register set cycle time	t _{RSC}	20		20		ns	
Transition time	t _T	1	30	1	30	ns	
Refresh time	t _{REF}		32		32	ms	

- ★
- ★
- ★

Relationship between Frequency and Latency

Speed version	-A10		-A12	
Clock cycle time [ns]	10	15	12	18
Frequency [MHz]	100	67	83	55
/CAS latency + 1 cycle	3 + 1	2 + 1	3 + 1	2 + 1
[t _{RCD}]	3	2	3	2
/RAS latency (/CAS latency + [t _{RCD}])	7	5	7	5
[t _{RC}]	10	7	9	6
[t _{RAS}]	6	4	6	4
[t _{RRD}]	2	2	2	2
[t _{RP}]	3	2	3	2
[t _{DPL}]	0	0	0	0
[t _{DAL}]	4	2	4	2

- ★
- ★

Remark All internal signals (A0-A11, /CS0, CKE0, /RAS, /CAS, /WE, DQM) from register are delayed by one cycle. Therefore, DQ is delayed by one cycle.

★ AC Parameters for Read Timing (Burst length = 2, /CAS latency = 2)

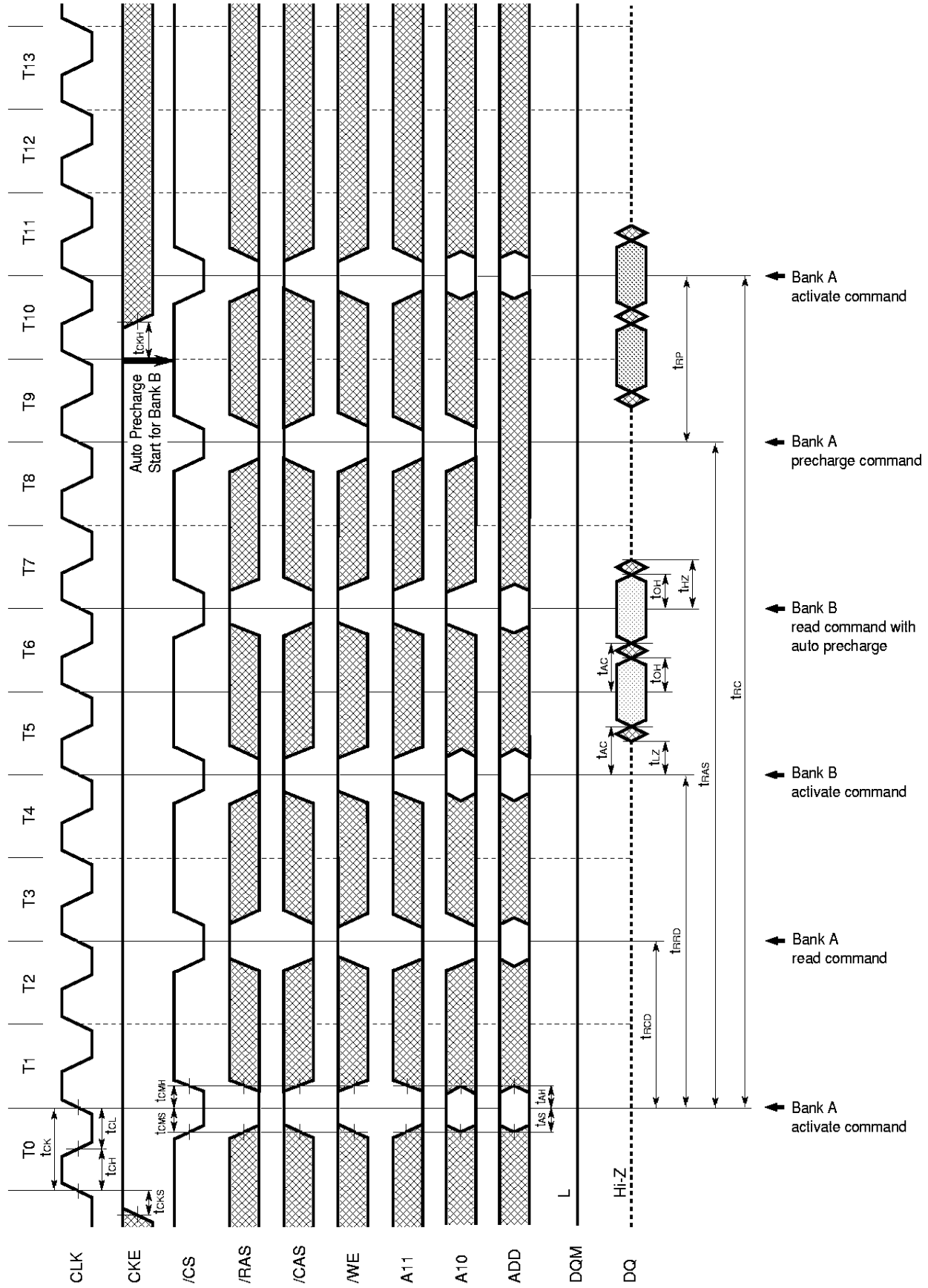

Remark All internal signals (A0 - A11, /CS0, /RAS, /CAS, /WE, DQM) from register are delayed by one cycle. Therefore, DQ is delayed by one cycle.

Package Drawing

200 PIN DUAL IN-LINE MODULE (SOKET TYPE)

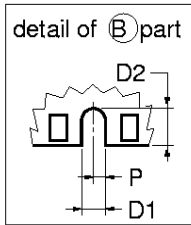
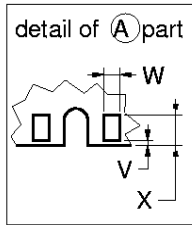
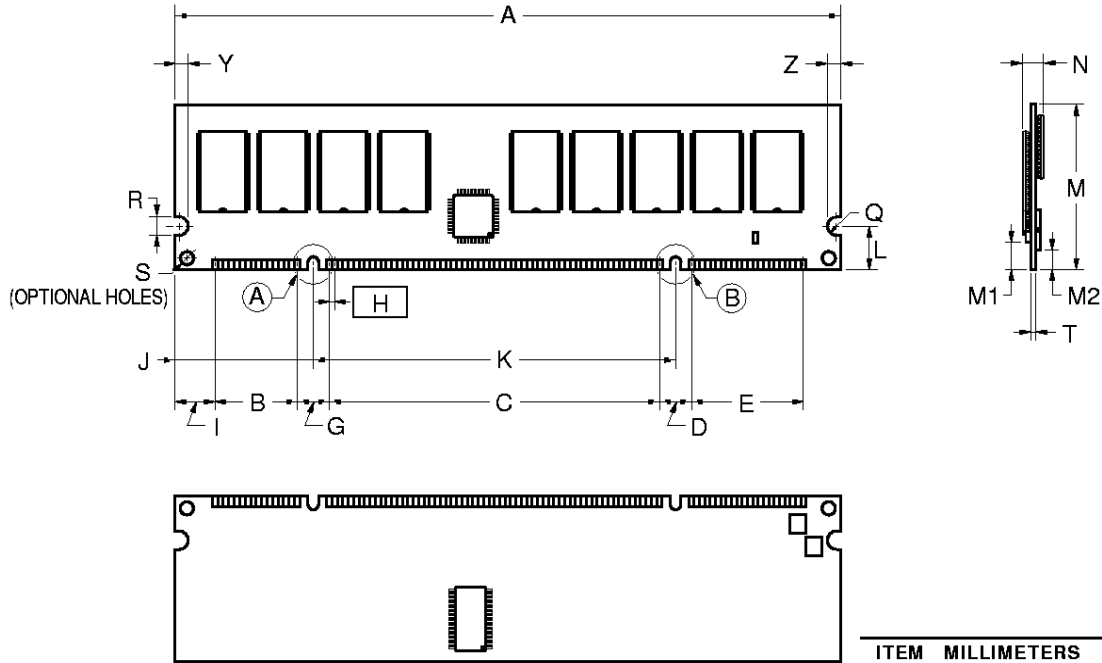

ITEM	MILLIMETERS	INCHES
A	153.7±0.13	6.051 ^{+0.006} _{-0.005}
B	19.05	0.750
C	77.47	3.050
D	6.35	0.250
D1	2.0	0.079
D2	3.125	0.123
E	26.67	1.050
G	6.35	0.250
H	1.27 (T.P.)	0.050 (T.P.)
I	8.91	0.351
J	31.130	1.226
K	83.82	3.300
L	10.0	0.394
M	38.1±0.13	1.500±0.006
M1	5.78 MIN.	0.227 MIN.
M2	5.45 MIN.	0.214 MIN.
N	4.0 MAX.	0.158 MAX.
P	1.0	0.039
Q	R2.0	R0.079
R	4.00±0.10	0.157 ^{+0.005} _{-0.004}
S	∅3.0	∅0.118
T	1.27±0.1	0.050±0.004
V	0.25 MAX.	0.010 MAX.
W	1.0±0.05	0.039 ^{+0.003} _{-0.002}
X	2.54±0.10	0.100±0.004
Y	3.0 MIN.	0.118 MIN.
Z	3.0 MIN.	0.118 MIN.

NOTES FOR CMOS DEVICES

① PRECAUTION AGAINST ESD FOR SEMICONDUCTORS

Note: Strong electric field, when exposed to a MOS device, can cause destruction of the gate oxide and ultimately degrade the device operation. Steps must be taken to stop generation of static electricity as much as possible, and quickly dissipate it once, when it has occurred. Environmental control must be adequate. When it is dry, humidifier should be used. It is recommended to avoid using insulators that easily build static electricity. Semiconductor devices must be stored and transported in an anti-static container, static shielding bag or conductive material. All test and measurement tools including work bench and floor should be grounded. The operator should be grounded using wrist strap. Semiconductor devices must not be touched with bare hands. Similar precautions need to be taken for PW boards with semiconductor devices on it.

② HANDLING OF UNUSED INPUT PINS FOR CMOS

Note: No connection for CMOS device inputs can be cause of malfunction. If no connection is provided to the input pins, it is possible that an internal input level may be generated due to noise, etc., hence causing malfunction. CMOS devices behave differently than Bipolar or NMOS devices. Input levels of CMOS device must be fixed high or low by using a pull-up or pull-down circuitry. Each unused pin should be connected to V_{DD} or GND with a resistor, if it is considered to have a possibility of being an output pin. All handling related to the unused pins must be judged device by device and related specifications governing the devices.

③ STATUS BEFORE INITIALIZATION OF MOS DEVICES

Note: Power-on does not necessarily define initial status of MOS device. Production process of MOS does not define the initial operation status of the device. Immediately after the power source is turned ON, the devices with reset function have not yet been initialized. Hence, power-on does not guarantee out-pin levels, I/O settings or contents of registers. Device is not initialized until the reset signal is received. Reset operation must be executed immediately after power-on for devices having reset function.

[MEMO]

No part of this document may be copied or reproduced in any form or by any means without the prior written consent of NEC Corporation. NEC Corporation assumes no responsibility for any errors which may appear in this document.

NEC Corporation does not assume any liability for infringement of patents, copyrights or other intellectual property rights of third parties by or arising from use of a device described herein or any other liability arising from use of such device. No license, either express, implied or otherwise, is granted under any patents, copyrights or other intellectual property rights of NEC Corporation or others.

While NEC Corporation has been making continuous effort to enhance the reliability of its semiconductor devices, the possibility of defects cannot be eliminated entirely. To minimize risks of damage or injury to persons or property arising from a defect in an NEC semiconductor device, customers must incorporate sufficient safety measures in its design, such as redundancy, fire-containment, and anti-failure features.

NEC devices are classified into the following three quality grades:

"Standard", "Special", and "Specific". The Specific quality grade applies only to devices developed based on a customer designated "quality assurance program" for a specific application. The recommended applications of a device depend on its quality grade, as indicated below. Customers must check the quality grade of each device before using it in a particular application.

Standard: Computers, office equipment, communications equipment, test and measurement equipment, audio and visual equipment, home electronic appliances, machine tools, personal electronic equipment and industrial robots

Special: Transportation equipment (automobiles, trains, ships, etc.), traffic control systems, anti-disaster systems, anti-crime systems, safety equipment and medical equipment (not specifically designed for life support)

Specific: Aircrafts, aerospace equipment, submersible repeaters, nuclear reactor control systems, life support systems or medical equipment for life support, etc.

The quality grade of NEC devices is "Standard" unless otherwise specified in NEC's Data Sheets or Data Books. If customers intend to use NEC devices for applications other than those specified for Standard quality grade, they should contact an NEC sales representative in advance.

Anti-radioactive design is not implemented in this product.