

**SN54HC147, SN54HC148**  
**SN74HC147, SN74HC148**  
**10-LINE TO 4-LINE AND 8-LINE TO 3-LINE PRIORITY ENCODERS**

D2844, MARCH 1984—REVISED SEPTEMBER 1987

**'HC147**

- Encodes 10-Line Decimal to 4-Line BCD
- Applications Include:  
 Keyboard Encoding  
 Range Selection

**'HC148**

- Encodes 8 Data Lines to 3-Line Binary (Octal)
- Applications Include:  
 N-Bit Encoding  
 Code Converters and Generators
- Package Options Include Plastic "Small Outline" Packages, Ceramic Chip Carriers, and Standard Plastic and Ceramic 300-mil DIPs
- Dependable Texas Instruments Quality and Reliability

**description**

These encoders feature priority decoding of the inputs to ensure that only the highest-order data line is encoded. The 'HC147 encodes nine data lines to four-line (8-4-2-1) BCD. The implied decimal zero condition requires no input condition as zero is encoded when all nine data lines are at a high logic level. The 'HC148 encodes eight data lines to three-line (4-2-1) binary (octal). Cascading circuitry (enable input EI and enable output EO) has been provided to allow octal expansion without the need for external circuitry. For all types, data inputs and outputs are active at the low logic level.

The SN54HC147 and SN54HC148 are characterized for operation over the full military temperature range of  $-55^{\circ}\text{C}$  to  $125^{\circ}\text{C}$ . The SN74HC147 and SN74HC148 are characterized for operation from  $-40^{\circ}\text{C}$  to  $85^{\circ}\text{C}$ .

**SN54HC147 . . . J PACKAGE**  
**SN74HC147 . . . DW OR N PACKAGE**

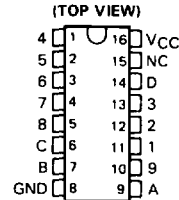

**SN54HC147 . . . FK PACKAGE**  
 (TOP VIEW)

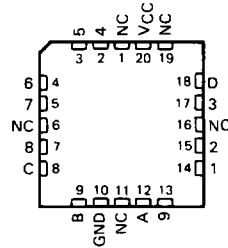

**SN54HC148 . . . J PACKAGE**  
**SN74HC148 . . . D/DW† OR N PACKAGE**

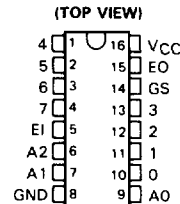

**SN54HC148 . . . FK PACKAGE**  
 (TOP VIEW)

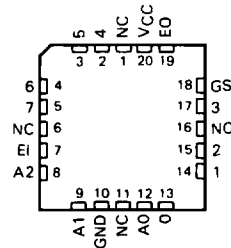

NC—No internal connection

†Contact the factory for D or DW availability.

**PRODUCTION DATA** documents contain information current as of publication date. Products conform to specifications per the terms of Texas Instruments standard warranty. Production processing does not necessarily include testing of all parameters.



**SN54HC147, SN54HC148  
SN74HC147, SN74HC148  
10-LINE TO 4-LINE AND 8-LINE TO 3-LINE PRIORITY ENCODERS**

**2**  
**HCMOS Devices**

**'HC147  
FUNCTION TABLE**

INPUTS									OUTPUTS			
1	2	3	4	5	6	7	8	9	D	C	B	A
H	H	H	H	H	H	H	H	H	H	H	H	H
X	X	X	X	X	X	X	X	L	L	H	H	L
X	X	X	X	X	X	X	L	H	L	H	H	H
X	X	X	X	X	X	L	H	H	H	L	L	L
X	X	X	X	X	L	H	H	H	H	L	L	H
X	X	X	X	L	H	H	H	H	H	L	H	L
X	X	X	L	H	H	H	H	H	H	L	H	H
X	X	L	H	H	H	H	H	H	H	L	L	L
X	L	H	H	H	H	H	H	H	H	L	L	H
L	H	H	H	H	H	H	H	H	H	H	L	H

**'HC148  
FUNCTION TABLE**

INPUTS								OUTPUTS					
EI	0	1	2	3	4	5	6	7	A2	A1	A0	GS	EO
H	X	X	X	X	X	X	X	X	H	H	H	H	H
L	H	H	H	H	H	H	H	H	H	H	H	H	L
L	X	X	X	X	X	X	X	L	L	L	L	L	H
L	X	X	X	X	X	X	L	H	L	L	H	L	H
L	X	X	X	X	L	H	H	H	L	H	L	L	H
L	X	X	X	X	L	H	H	H	L	H	H	L	H
L	X	X	X	L	H	H	H	H	H	L	L	L	H
L	X	X	L	H	H	H	H	H	H	L	H	L	H
L	X	L	H	H	H	H	H	H	H	H	L	L	H
L	L	H	H	H	H	H	H	H	H	H	H	L	H

H = high logic level, L = low logic level, X = irrelevant

logic symbols†

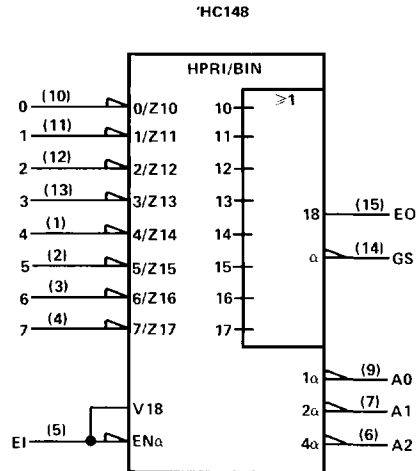
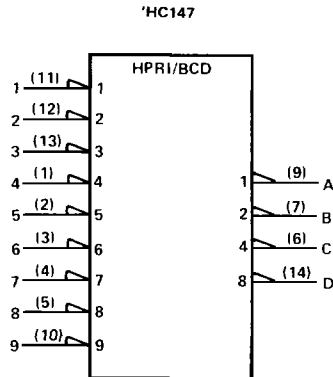

† These symbols are in accordance with ANSI/IEEE Std 91-1984 and IEC Publication 617-12. Pin numbers shown are for D<sup>2</sup>DW, J, and N packages.

**SN54HC147, SN54HC148**  
**SN74HC147, SN74HC148**  
**10-LINE TO 4-LINE AND 8-LINE TO 3-LINE PRIORITY ENCODERS**

logic diagrams (positive logic)

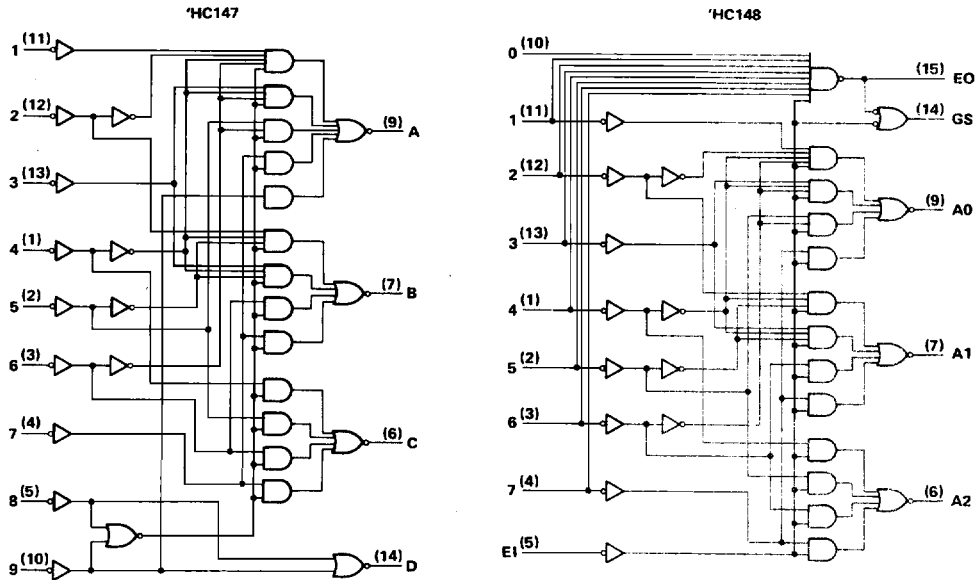

Pin numbers shown are for D/DW, J, and N packages.

**absolute maximum ratings over operating free-air temperature†**

Supply voltage, $V_{CC}$ .....	-0.5 V to 7 V
Input clamp current, $I_{IK}$ ( $V_I < 0$ or $V_I > V_{CC}$ ) .....	$\pm 20$ mA
Output clamp current, $I_{OK}$ ( $V_O < 0$ or $V_O > V_{CC}$ ) .....	$\pm 20$ mA
Continuous output current, $I_O$ ( $V_O = 0$ to $V_{CC}$ ) .....	$\pm 25$ mA
Continuous current through $V_{CC}$ or GND pins .....	$\pm 50$ mA
Lead temperature 1,6 mm (1/16 in) from case for 60 s: FK or J package .....	300°C
Lead temperature 1,6 mm (1/16 in) from case for 10 s: D or N package .....	260°C
Storage temperature range .....	-65°C to 150°C

† Stresses beyond those listed under "absolute maximum ratings" may cause permanent damage to the device. These are stress ratings only, and functional operation of the device at these or any other conditions beyond those indicated under "recommended operating conditions" is not implied. Exposure to absolute-maximum-rated conditions for extended periods may affect device reliability.

2

HC MOS Devices

**SN54HC147, SN54HC148**  
**SN74HC147, SN74HC148**  
**10-LINE TO 4-LINE AND 8-LINE TO 3-LINE PRIORITY ENCODERS**

**recommended operating conditions**

		SN54HC147 SN54HC148			SN74HC147 SN74HC148			UNIT
		MIN	NOM	MAX	MIN	NOM	MAX	
$V_{CC}$ Supply voltage		2	5	6	2	5	6	V
$V_{IH}$ High-level input voltage	$V_{CC} = 2\text{ V}$	1.5			1.5			V
	$V_{CC} = 4.5\text{ V}$	3.15			3.15			
	$V_{CC} = 6\text{ V}$	4.2			4.2			
$V_{IL}$ Low-level input voltage	$V_{CC} = 2\text{ V}$	0	0.3		0	0.3		V
	$V_{CC} = 4.5\text{ V}$	0	0.9		0	0.9		
	$V_{CC} = 6\text{ V}$	0	1.2		0	1.2		
$V_I$ Input voltage		0	$V_{CC}$		0	$V_{CC}$		V
$V_O$ Output voltage		0	$V_{CC}$		0	$V_{CC}$		V
$t_t$ Input transition (rise and fall) times	$V_{CC} = 2\text{ V}$	0	1000		0	1000		ns
	$V_{CC} = 4.5\text{ V}$	0	500		0	500		
	$V_{CC} = 6\text{ V}$	0	400		0	400		
$T_A$ Operating free-air temperature		-55	125		-40	85		°C

**electrical characteristics over recommended operating free-air temperature range (unless otherwise noted)**

PARAMETER	TEST CONDITIONS	$V_{CC}$	$T_A = 25^\circ\text{C}$			SN54HC147 SN54HC148	SN74HC147 SN74HC148	UNIT
			MIN	TYP	MAX	MIN	MAX	
$V_{OH}$	$V_I = V_{IH}$ or $V_{IL}$ , $I_{OH} = -20\ \mu\text{A}$	2 V	1.9	1.998		1.9	1.9	V
		4.5 V	4.4	4.499		4.4	4.4	
		6 V	5.9	5.999		5.9	5.9	
	4.5 V	3.98	4.30		3.7	3.84		
$V_{OL}$	$V_I = V_{IH}$ or $V_{IL}$ , $I_{OL} = 20\ \mu\text{A}$	2 V		0.002	0.1		0.1	V
		4.5 V		0.001	0.1		0.1	
		6 V		0.001	0.1		0.1	
	4.5 V		0.17	0.26		0.4	0.33	
$I_I$	$V_I = V_{CC}$ or 0	6 V	$\pm 0.1$	$\pm 100$		$\pm 1000$	$\pm 1000$	nA
		6 V		8		160	80	$\mu\text{A}$
$I_{CC}$	$V_I = V_{CC}$ or 0, $I_O = 0$	6 V		8		160	80	$\mu\text{A}$
$C_i$		2 to 6 V	3	10		10	10	pF

**\*HC147 switching characteristics over recommended operating free-air temperature range (unless otherwise noted),  $C_L = 50\text{ pF}$  (see Note 1)**

PARAMETER	FROM (INPUT)	TO (OUTPUT)	$V_{CC}$	$T_A = 25^\circ\text{C}$			SN54HC147	SN74HC147	UNIT	
				MIN	TYP	MAX	MIN	MAX		MIN
$t_{pd}$	Any	Any	2 V		75	190		285	240	ns
			4.5 V		25	38		57	48	
			6 V		21	32		48	41	
$t_t$		Any	2 V		28	75		110	95	ns
			4.5 V		8	15		22	19	
			6 V		6	13		19	16	

NOTE 1: Load circuit and voltage waveforms are shown in Section 1.

2

HCMOS Devices

**SN54HC147, SN54HC148**  
**SN74HC147, SN74HC148**  
**10-LINE TO 4-LINE AND 8-LINE TO 3-LINE PRIORITY ENCODERS**

**\*HC148 switching characteristics over recommended operating free-air temperature range (unless otherwise noted),  $C_L = 50$  pF (see Note 1)**

PARAMETER	FROM (INPUT)	TO (OUTPUT)	V <sub>CC</sub>	T <sub>A</sub> = 25°C			SN54HC148		SN74HC148		UNIT
				MIN	TYP	MAX	MIN	MAX	MIN	MAX	
t <sub>pd</sub>	1-7	A0, A1, or A2	2 V		69	180		270		225	ns
			4.5 V		23	36		54		45	
			6 V		21	31		46		38	
t <sub>pd</sub>	0-7	EO	2 V		60	150		225		190	ns
			4.5 V		20	30		45		38	
			6 V		17	26		38		33	
t <sub>pd</sub>	0-7	GS	2 V		75	190		285		240	ns
			4.5 V		25	38		57		48	
			6 V		21	32		48		41	
t <sub>pd</sub>	EI	A0, A1, or A2	2 V		78	195		295		245	ns
			4.5 V		26	39		59		49	
			6 V		22	33		50		42	
t <sub>pd</sub>	EI	GS	2 V		57	145		220		180	ns
			4.5 V		19	29		44		36	
			6 V		16	25		38		31	
t <sub>pd</sub>	EI	EO	2 V		66	165		250		205	ns
			4.5 V		22	33		50		41	
			6 V		19	28		43		35	
t <sub>t</sub>		Any	2 V		28	75		110		95	ns
			4.5 V		8	15		22		19	
			6 V		6	13		19		16	

NOTE 1: Load circuit and voltage waveforms are shown in Section 1.

**2**

**HCMOS Devices**

**SN54HC147, SN54HC148  
SN74HC147, SN74HC148  
10-LINE TO 4-LINE AND 8-LINE TO 3-LINE PRIORITY ENCODERS**

**2**

**HCMOS Devices**

**TYPICAL APPLICATION DATA**

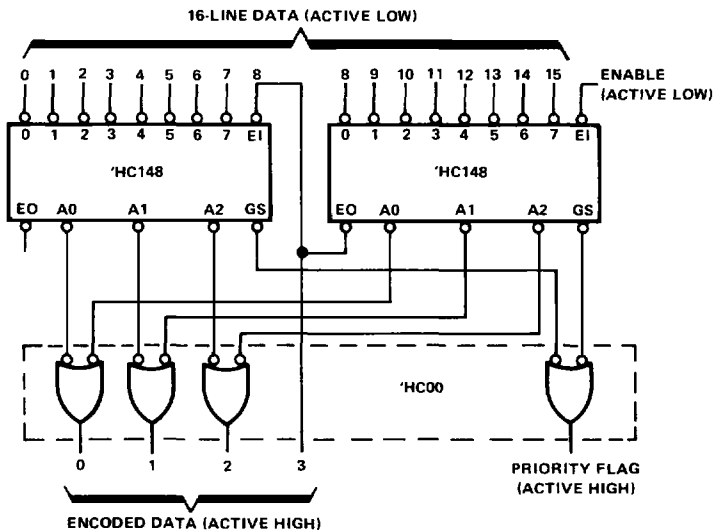
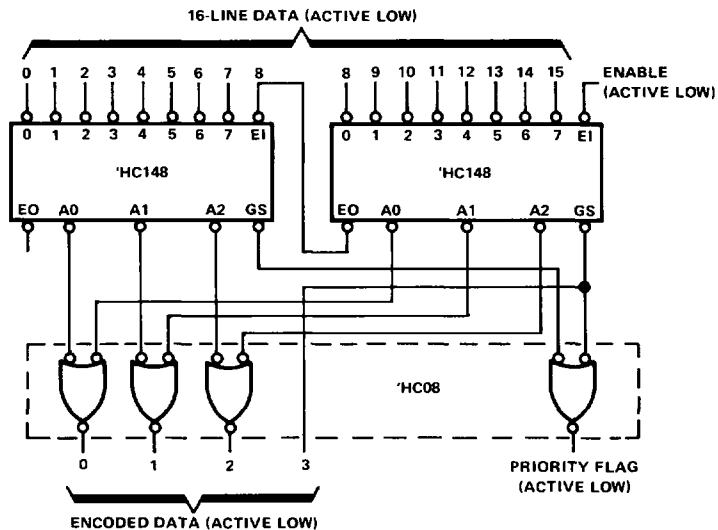

**PRIORITY ENCODER FOR 16 BITS**

Since the 'HC147 and 'HC148 are combinational logic circuits, wrong addresses can appear during input transients. Moreover, for the 'HC148, a change from high to low at input EI can cause a transient low on the GS output when all inputs are high. This must be considered when strobing the outputs.