

FOUR CHANNEL HD AUDIO CODEC

92HD75B

LOW POWER OPTIMIZED

Description

The 92HD75B is a low power optimized, high fidelity, 4-channel audio codec compatible with Intel's High Definition (HD) Audio Interface. The 92HD75B provides stereo 24-bit resolution with sample rates up to 192kHz. The 92HD75B provides high quality, HD Audio capability to notebook and business desktop PC applications.

Features

- **4 Channels (2 stereo DACs and 2 stereo ADCs) with 24-bit resolution**
 - Supports full-duplex stereo audio and simultaneous VoIP
 - Provides a mono output
- **Microsoft WLP 3/4 premium logo compliant, as defined in WLP 3.09**
- **Optimized and flexible power management with pop/click mitigation**
- **Support for 1.5V and 3.3V HDA signaling**

- **Digital microphone inputs (mono or stereo*)**
- **High performance analog mixer**
- **2 or 3* adjustable VREF Out pins for microphone bias**
- **5 or 6* analog ports with port presence detect**
- **Two-pin volume up/down control**
- **Digital and Analog PC Beep to all outputs**
- **Integrated headphone amp**
- **Sample rates up to 192kHz**
- **+3.3 V, +4.75 V and +5 V analog power supply options**
- **3.3V digital power supply options**
- **32-pad and 48-pad QFN RoHS packages**

*dependant on package option

Block Diagram

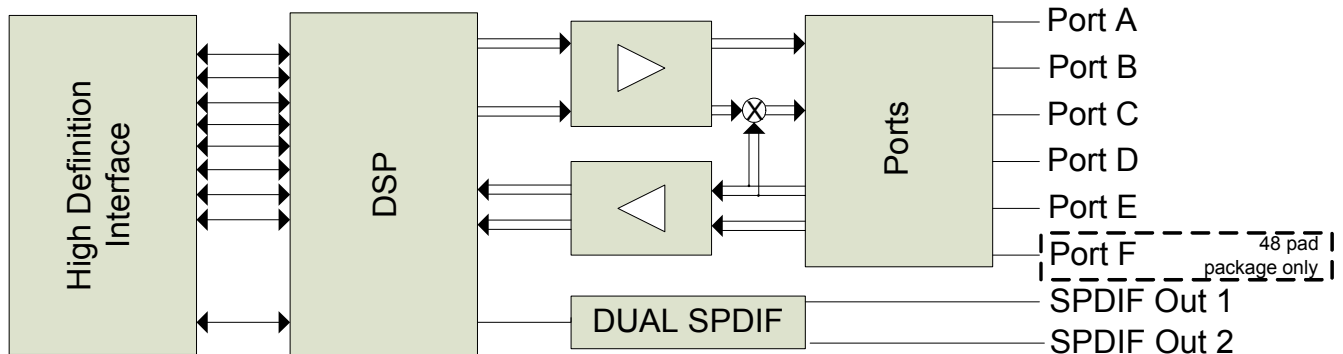

Software Support

- Intuitive graphical user interface that allows configurability and preference settings
- SKPI (Kernel Processing Interface)
 - Enables plug-ins that can operate globally on all audio streams of the system
- 12 band fully parametric equalizer (SKPI plug-in)
 - Constant, system-level effects tuned to optimize a particular platform can be combined with user-mode “presets” tailored for specific acoustical environments and applications
 - System-level effects automatically disabled when external audio connections made
- Dynamics Processing (SKPI plug-in)
 - Enables improved voice articulation
 - Compressor/limiter allows higher average noise level without resonances
- IDT Vista APO wrapper
 - Enables multiple APOs to be used with the IDT Driver
- Microphone Beam Forming, Acoustic Echo Cancellation, and Noise Suppression
- Dynamic Stream Switching
 - Improved multi-streaming user experience with less support calls
- Dolby PC Entertainment Experience Logo Program
 - Dolby Home Theater™ (HT)
 - Dolby Sound Room™ (SR)
- Dolby Technologies
 - Dolby Headphone™, Dolby Virtual Speaker™
 - Dolby ProLogic II™, Dolby ProLogic IIx™
 - Dolby Digital Live™ (DDL)
- Maxx Player™ from Waves
- WOW™ and Tru Surround™ from SRS

TABLE OF CONTENTS

1. DESCRIPTION	5
1.1. Overview	5
1.2. Orderable Part numbers	5
1.3. Block Diagram	6
1.4. Detailed Description	7
1.4.1. Low-voltage High Definition Audio Link Signaling	7
1.4.2. Port Functionality	7
1.4.3. Port Characteristics	7
1.4.4. Jack Detect	8
1.4.5. SPDIF Output	8
1.4.6. Mono Output	10
1.4.7. Input Multiplexers	10
1.4.8. ADC Multiplexers	10
1.4.9. Power Management	10
1.4.10. Multi-channel capture	11
1.4.11. EAPD	12
1.4.12. Digital Microphone Support	13
1.4.13. Analog PC-Beep	18
1.4.14. Headphone Drivers	18
1.4.15. GPIO	18
1.4.16. External Volume Control (48 pad package only)	19
2. CHARACTERISTICS	21
2.1. Electrical Specifications	21
2.1.1. Absolute Maximum Ratings	21
2.1.2. Recommended Operating Conditions	21
2.2. 92HD75B 5V, 4.75V, and 3.3V Analog Performance Characteristics	22
3. PORT CONFIGURATIONS	28
4. FUNCTIONAL BLOCK DIAGRAMS	29
4.1. 32 pad package, 5 port	29
4.2. 48 pad package, 6 port	30
5. WIDGET INFORMATION AND SUPPORTED COMMAND VERBS	31
5.1. 5-port 32 pad Widget Diagram	31
5.2. 6-port 48 pad Widget Diagram	32
5.3. Widget List 92HD75B	33
6. PIN CONFIGURATION DEFAULT REGISTER SETTINGS	34
7. WIDGET INFORMATION	35
8. SUPPORTED VERBS AND COMMANDS	36
8.1. Root Node (NID = 00)	36
8.1.1. Root VendorID	36
8.1.2. Root RevID	36
8.2. AFG Node (NID = 01)	37
8.2.1. AFG Reset	37
8.2.2. AFG NodeInfo	37
8.2.4. AFG AFGCap	38
8.2.3. AFG FGType	38
8.2.5. AFG PCMCap	39
8.2.6. AFG StreamCap	40
8.2.7. AFG InAmpCap	41
8.2.8. AFG PwrStateCap	41
8.2.10. AFG OutAmpCap	42
8.2.9. AFG GPIOCnt	42
8.2.12. AFG UnsolResp	43
8.2.11. AFG PwrState	43

8.2.13. AFG GPIO	44
8.2.14. AFG GPIOEn	45
8.2.15. AFG GPIODir	46
8.2.16. AFG GPIOWakeEn	47
8.2.17. AFG GPIOUnsol	49
8.2.18. AFG GPIOSticky	51
8.2.19. AFG SubID	52
8.2.20. AFG GPIOIrty	52
8.2.21. AFG GPIODrive	53
8.2.22. AFG DMic	54
8.2.23. AFG Misc. (B3 revision and beyond only)	55
8.3. Port A Node (NID = 0A)	56
8.3.1. PortA WCap	56
8.3.2. PortA PinCap	57
8.3.3. PortA ConLst	58
8.3.4. PortA ConLstEntry0	59
8.3.5. PortA ConSelectCtrl	59
8.3.6. PortA PinWCntrl	59
8.3.7. PortA UnsolResp	60
8.3.8. PortA ChSense	60
8.3.9. PortA InAmpLeft	61
8.3.10. PortA InAmpRight	61
8.3.11. PortA ConfigDefault	62
8.4. PortB Node (NID = 0B)	63
8.4.1. PortB WCap	63
8.4.2. PortB PinCap	64
8.4.3. PortB PinWCntrl	65
8.4.4. PortB UnsolResp	66
8.4.5. PortB ChSense	67
8.4.6. PortB ConfigDefault	67
8.5. Port C Node (NID = 0C)	68
8.5.1. PortC WCap	68
8.5.2. PortC PinCap	70
8.5.3. PortC PinWCntrl	71
8.5.4. PortC UnsolResp	71
8.5.5. PortC ChSense	72
8.5.6. PortC ConfigDefault	72
8.6. Port D Node (NID = 0D)	74
8.6.1. PortD WCap	74
8.6.2. PortD PinCap	75
8.6.3. PortD ConLst	76
8.6.4. PortD ConLstEntry0	76
8.6.5. PortD ConSelectCtrl	77
8.6.6. PortD PinWCntrl	77
8.6.7. PortD UnsolResp	78
8.6.8. PortD ChSense	78
8.6.9. PortD InAmpLeft	79
8.6.10. PortD InAmpRight	79
8.6.11. PortD ConfigDefault	80
8.7. PortE Node (NID = 0E)	81
8.7.1. PortE WCap	81
8.7.2. PortE PinCap	82
8.7.3. PortE PinWCntrl	83
8.7.4. PortE UnsolResp	84
8.7.5. PortE ChSense	85

8.7.6. PortE ConfigDefault	85
8.8. PortF Node (NID = 0F)	86
8.8.1. PortF WCap	86
8.8.2. PortF PinCap	88
8.8.3. PortF ConLst	89
8.8.4. PortF ConLstEntry0	89
8.8.5. PortF ConSelectCtrl	90
8.8.6. PortF PinWCntrl	90
8.8.7. PortF UnsolResp	90
8.8.8. PortF ChSense	91
8.8.9. PortF InAmpLeft	91
8.8.10. PortF InAmpRight	92
8.8.11. PortF ConfigDefault	92
8.9. DAC0 Node (NID = 10)	94
8.9.1. DAC0 WCap	94
8.9.2. DAC0 Cnvtr	95
8.9.3. DAC0 OutAmpLeft	96
8.9.4. DAC0 OutAmpRight	96
8.9.5. DAC0 PwrState	97
8.9.6. DAC0 CnvtrID	97
8.9.7. DAC0 LR	98
8.10. DAC1 Node (NID = 11)	98
8.10.1. DAC1 WCap	98
8.10.2. DAC1 Cnvtr	100
8.10.3. DAC1 OutAmpLeft	101
8.10.4. DAC1 OutAmpRight	101
8.10.5. DAC1 PwrState	102
8.10.6. DAC1 CnvtrID	102
8.10.7. DAC1 LR	103
8.11. ADC0 Node (NID = 12)	103
8.11.1. ADC0 WCap	103
8.11.2. ADC0 ConLst	104
8.11.3. ADC0 ConLstEntry0	105
8.11.4. ADC0 Cnvtr	105
8.11.5. ADC0 ProcState	106
8.11.6. ADC0 PwrState	107
8.11.7. ADC0 CnvtrID	107
8.12. ADC1 Node (NID = 13)	108
8.12.1. ADC1 WCap	108
8.12.2. ADC1 ConLst	109
8.12.3. ADC1 ConLstEntry0	110
8.12.4. ADC1 Cnvtr	110
8.12.5. ADC1 ProcState	111
8.12.6. ADC1 PwrState	112
8.12.7. ADC1 CnvtrID	112
8.13. PCBeep/MonoOut Node (NID = 14)	113
8.13.1. PCBeep/MonoOut WCap	113
8.13.2. PCBeep/MonoOut PinCap	114
8.13.3. PCBeep/MonoOut ConLst	115
8.13.4. PCBeep/MonoOut ConLstEntry0	115
8.13.5. PCBeep/MonoOut PinWCntrl	116
8.13.6. PCBeep/MonoOut InAmpLeft	116
8.13.7. PCBeep/MonoOut ConfigDefault	117
8.14. MonoMux Node (NID = 15)	118
8.14.1. MonoMux WCap	118

8.14.2. MonoMux ConLst	119
8.14.3. MonoMux ConLstEntry0	120
8.14.4. MonoMux ConSelectCtrl	120
8.15. MonoMixer Node (NID = 16)	121
8.15.1. MonoMixer WCap	121
8.15.2. MonoMixer ConLst	122
8.15.3. MonoMixer ConLstEntry0	123
8.16. InputMixer Node (NID = 17)	123
8.16.1. InputMixer WCap	123
8.16.2. InputMixer ConLst	124
8.16.3. InputMixer ConLstEntry4	125
8.16.4. InputMixer ConLstEntry0	125
8.16.5. InputMixer InAmpCap	126
8.16.6. InputMixer InAmpLeft0	127
8.16.7. InputMixer InAmpRight0	127
8.16.8. InputMixer InAmpLeft1	128
8.16.9. InputMixer InAmpRight1	128
8.16.10. InputMixer InAmpLeft2	129
8.16.11. InputMixer InAmpRight2	129
8.16.12. InputMixer InAmpLeft3	130
8.16.13. InputMixer InAmpRight3	130
8.16.14. InputMixer InAmpLeft4	131
8.16.15. InputMixer InAmpRight4	131
8.17. DMic0 Node (NID = 18)	132
8.17.1. DMic0 WCap	132
8.17.2. DMic0 PinCap	133
8.17.3. DMic0 PinWCntrl	134
8.17.4. DMic0 InAmpCap	134
8.17.5. DMic0 InAmpLeft	135
8.17.6. DMic0 InAmpRight	135
8.17.7. DMic0 ConfigDefault	136
8.18. DMic1 Node (NID = 19)	137
8.18.1. DMic1 WCap	137
8.18.2. DMic1 PinCap	138
8.18.3. DMic1 PinWCntrl	139
8.18.4. DMic1 InAmpCap	140
8.18.5. DMic1 InAmpLeft	141
8.18.6. DMic1 InAmpRight	141
8.18.7. DMic1 ConfigDefault	141
8.19. InPort0Mux Node (NID = 1A)	143
8.19.1. InPort0Mux WCap	143
8.19.2. InPort0Mux ConLst	144
8.19.3. InPort0Mux ConLstEntry0	144
8.19.4. InPort0Mux ConSelectCtrl	145
8.19.5. InPort0Mux OutAmpCap	145
8.19.6. InPort0Mux OutAmpLeft	146
8.19.7. InPort0Mux OutAmpRight	146
8.20. InPort1Mux Node (NID = 1B)	147
8.20.1. InPort1Mux WCap	147
8.20.2. InPort1Mux ConLst	148
8.20.3. InPort1Mux ConLstEntry0	149
8.20.4. InPort1Mux ConSelectCtrl	149
8.20.5. InPort1Mux OutAmpCap	149
8.20.6. InPort1Mux OutAmpLeft	150
8.20.7. InPort1Mux OutAmpRight	151

8.21. ADC0Mux Node (NID = 1C)	151
8.21.1. ADC0Mux WCap	151
8.21.2. ADC0Mux ConLst	152
8.21.3. ADC0Mux ConLstEntry0	153
8.21.4. ADC0Mux ConSelectCtrl	153
8.21.5. ADC0Mux LR	154
8.21.6. ADC0Mux OutAmpCap	154
8.21.7. ADC0Mux OutAmpLeft	155
8.21.8. ADC0Mux OutAmpRight	156
8.22. ADC1Mux Node (NID = 1D)	156
8.22.1. ADC1Mux WCap	156
8.22.2. ADC1Mux ConLst	157
8.22.3. ADC1Mux ConLstEntry0	158
8.22.4. ADC1Mux ConSelectCtrl	158
8.22.5. ADC1Mux LR	159
8.22.6. ADC1Mux OutAmpCap	159
8.22.7. ADC1Mux OutAmpLeft	160
8.22.8. ADC1Mux OutAmpRight	161
8.23. Dig0Pin Node (NID = 1E)	161
8.23.1. Dig0Pin WCap	161
8.23.2. Dig0Pin PinCap	162
8.23.3. Dig0Pin ConLst	163
8.23.4. Dig0Pin ConLstEntry0	164
8.23.5. Dig0Pin PinWCntrl	164
8.23.6. Dig0Pin ConfigDefault	165
8.24. Dig1Pin Node (NID = 1F)	166
8.24.1. Dig1Pin WCap	166
8.24.2. Dig1Pin PinCap	168
8.24.3. Dig1Pin ConLst	169
8.24.4. Dig1Pin ConLstEntry0	169
8.24.5. Dig1Pin ConSelectCtrl	170
8.24.6. Dig1Pin PinWCntrl	170
8.24.7. Dig1Pin PwrState	170
8.24.8. Dig1Pin EAPD	171
8.24.9. Dig1Pin ConfigDefault	171
8.25. Dig2Pin Node (NID = 20)	173
8.25.1. Dig2Pin WCap	173
8.25.2. Dig2Pin PinCap	174
8.25.3. Dig2Pin ConLst	175
8.25.4. Dig2Pin ConLstEntry0	175
8.25.5. Dig2Pin PinWCntrl	176
8.25.6. Dig2Pin ConfigDefault	176
8.26. SPDIFOut0 Node (NID = 21)	178
8.26.1. SPDIFOut0 WCap	178
8.26.2. SPDIFOut0 PCMCap	179
8.26.3. SPDIFOut0 StreamCap	180
8.26.4. SPDIFOut0 Cnvtr	181
8.26.5. SPDIFOut0 CnvtrID	182
8.26.6. SPDIFOut0 DigCnvtr	182
8.27. SPDIFOut1 Node (NID = 22)	183
8.27.1. SPDIFOut1 WCap	183
8.27.2. SPDIFOut1 PCMCap	184
8.27.3. SPDIFOut1 StreamCap	185
8.27.4. SPDIFOut1 Cnvtr	186
8.27.5. SPDIFOut1 CnvtrID	187

8.27.6. SPDIFOut1 DigCnvtr	187
8.28. Vendor Reserved (NID=23)	188
8.29. Dig0Mux Node (NID = 24)	188
8.29.1. Dig0Mux WCap	188
8.29.2. Dig0Mux ConLst	190
8.29.3. Dig0Mux ConLstEntry0	190
8.29.4. Dig0Mux ConSelectCtrl	191
8.30. Dig2Mux Node (NID = 25)	191
8.30.1. Dig2Mux WCap	191
8.30.2. Dig2Mux ConLst	192
8.30.3. Dig2Mux ConLstEntry0	193
8.30.4. Dig2Mux ConSelectCtrl	193
8.31. DigBeep Node (NID = 26)	194
8.31.1. DigBeep WCap	194
8.31.2. DigBeep OutAmpCap	195
8.31.3. DigBeep OutAmpLeft	195
8.31.4. DigBeep Gen	196
8.31.5. DigBeep Mode	197
8.32. VolumeKnob Node (NID = 27)	197
8.32.1. VolumeKnob WCap	197
8.32.2. VolumeKnob VolKnobCap	198
8.32.3. VolumeKnob ConLst	198
8.32.4. VolumeKnob ConLstEntry0	199
8.32.5. VolumeKnob UnsolResp	199
8.32.6. VolumeKnob Cntrl	200
8.32.7. VolumeKnob Update	200
9. DISCLAIMER	201
10. PINOUTS	202
10.1. Pin Assignment - 32 pad	202
10.2. Pin Assignment - 48 pad	203
10.3. Pin Descriptions	204
11. PACKAGE OUTLINE AND PACKAGE DIMENSIONS	206
11.1. 32-Pad QFN Package	206
11.2. 48-Pad QFN Package	207
12. SOLDER REFLOW PROFILE	208
12.1. Standard Reflow Profile Data	208
12.2. Pb Free Process - Package Classification Reflow Temperatures	209
13. REVISION HISTORY	209

LIST OF FIGURES

Figure 1. 92HD75B Block Diagram	11
Figure 2. System Diagram	11
Figure 3. Jack Detect	13
Figure 4. Multi-channel capture	17
Figure 5. Multi-channel timing diagram	17
Figure 6. Single Digital Microphone (data is ported to both left and right channels)	20
Figure 7. Stereo Digital Microphone Configuration	21
Figure 8. Quad Digital Microphone Configuration	22
Figure 9. Volume Knob	25
Figure 10. Port Configurations	33
Figure 11. 92HD75B 5-port 32 pad Functional Block Diagram	34
Figure 12. 92HD75B 6-port 48 pad Functional Block Diagram	35
Figure 13. 92HD75B 5-port 32 pad Widget Diagram	36
Figure 14. 92HD75B 6-port 48 pad Widget Diagram	37
Figure 15. 32 Pad Assignment	207
Figure 16. 48 Pad Assignment	208
Figure 17. 32-pad QFN Package Drawing	211
Figure 18. 48-pad QFN Package Drawing	212
Figure 19. Solder Reflow Profile	213

LIST OF TABLES

Table 1. Analog Output Port Behavior	13
Table 2. SPDIF OUT 0 (Pin 48) Behavior	14
Table 3. SPDIF OUT 1 (Pin 45) Behavior	14
Table 4. Power Managemen	16
Table 6. EAPD Behavior	18
Table 7. Valid Digital Mic Configurations	19
Table 8. DMIC_CLK and DMIC_0,1 Operation During Power States	19
Table 9. GPIO Pin mapping and shared functions	23
Table 10. Electrical Specification: Maximum Ratings	26
Table 11. Recommended Operating Conditions	26
Table 12. 92HD75B 5V, 4.75V, and 3.3V Analog Performance Characteristics	27
Table 13. High Definition Audio Widget	38
Table 14. Pin Configuration Default Settings	39
Table 15. Command Format for Verb with 4-bit Identifier	40
Table 16. Command Format for Verb with 12-bit Identifier	40
Table 17. Solicited Response Format	40
Table 18. Unsolicited Response Format	40
Table 19. Pin descriptions	209
Table 20. Standard Reflow Profile	213
Table 21. Pb-Free Process Reflow	214

1. DESCRIPTION

1.1. Overview

The 92HD75B is a high fidelity, 4-channel audio codec compatible with the Intel High Definition (HD) Audio Interface. The 92HD75B codecs provide high quality, HD Audio capability to notebook and cost sensitive desktop PC applications.

The higher performance and quality of IDT's audio solutions brings consumer electronics level performance to notebook and desktop PCs. 92HD75B is designed to meet or exceed premium logo requirements for Microsoft's Windows Logo Program (WLP) 3.09 and revisions 4 as indicated in WLP 3.09.

The 92HD75B provides stereo 24-bit, full duplex resolution supporting sample rates up to 192kHz by the DAC and ADC. The 92HD75B SPDIF outputs support sample rates of 192kHz, 96kHz, 88.2kHz, 48kHz, and 44.1kHz. Additional sample rates are supported by the driver software.

The 92HD75B supports a wide range of mobile and desktop 4 channel configurations. The 2 independent SPDIF output interfaces provide connectivity to Consumer Electronic equipment like Dolby Digital decoders, powered speakers, mini disk drives or to a home entertainment system. Simultaneous WLP compliant HDMI and SPDIF output is possible. All analog input pairs support LINE_IN and MIC.

MIC inputs can be programmed with 0/10/20/30dB boost. (40dB boost is available using the IDT driver.) For more advanced configurations, the 92HD75B has up to 8 General Purpose I/O (GPIO).

The port presence detect capabilities allow the codecs to detect when audio devices are connected to the codec. The fully parametric IDT SoftEQ can be initiated or disabled upon headphone jack removal and insertion for protection of notebook speakers.

The 92HD75B operates with a 3.3V digital supply and either 3.3V, 4V, 4.75V or 5V analog supply. It can also work with 1.5V and 3.3V HDA signaling; the correct signalling level is selected dynamically based on the power supply voltage on the DVDD-IO pin in 48 pad package or as an orderable option with 32 pad packages.

Available in a 32-pad QFN or 48-pad QFN Environmental (ROHS) packages.

1.2. Orderable Part numbers

92HD75B1X5NLGXyyX	Pico, 32QFN, 5 port, 5V Analog, 1.5V HD Audio signaling
92HD75B1X3NLGXyyX	Pico, 32QFN, 5 port, 3.3V Analog, 1.5V HD Audio signaling
92HD75B2X5NLGXyyX	Pico, 32QFN, 5 port, 5V Analog, 3.3V HD Audio signaling
92HD75B2X3NLGXyyX	Pico, 32QFN, 5 port, 3.3V Analog, 3.3V HD Audio signaling
92HD75B3X5NLGXyyX	Pico, 48QFN, 6 port, 5V Analog, 3.3V HD Audio signaling
92HD75B3X3NLGXyyX	Pico, 48QFN, 6 port, 3.3V Analog, 3.3V HD Audio signaling
92HD75B4X5NLGXyyX	Pico, 48QFN, 6 port, 5V Analog, 1.5V HD Audio signaling
92HD75B4X3NLGXyyX	Pico, 48QFN, 6 port, 3.3V Analog, 1.5V HD Audio signaling

yy = silicon stepping/revision, contact sales for current data. Add an "8" to the end for tape and reel delivery. Min/Mult order quantity 2ku for 48QFN, 2.5ku for 32QFN.

1.3. Block Diagram

Figure 1. 92HD75B Block Diagram

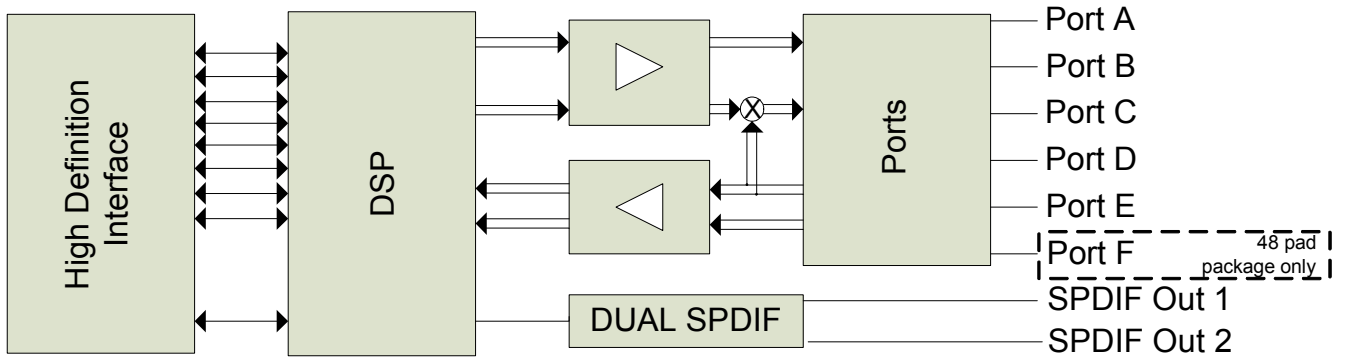
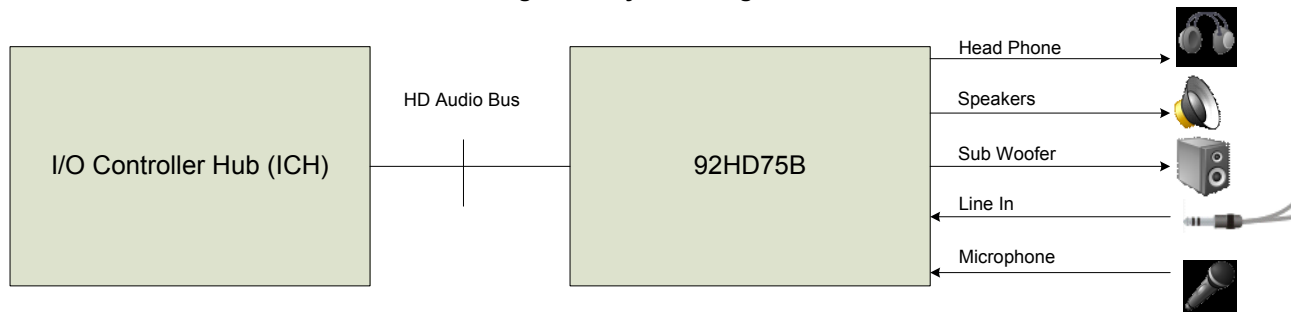

Figure 2. System Diagram



1.4. Detailed Description

1.4.1. Low-voltage High Definition Audio Link Signaling

The 92HD75B is compatible with either 1.5 V or 3.3 V High Definition Audio Link signaling; the voltage selection is performed dynamically based on the input voltage of DVDD_IO in 48 pad package. Note that DVDD_IO is not a logic configuration pin but provides the digital power supply to be used for the High Definition Audio Link signals. Different orderable part numbers are assigned. The 32 pad package does not have DVDD_IO so selection of 1.5V or 3.3V High Definition Audio Link signaling is by two different orderable parts. Please see the orderable part number section for more details.

When in 1.5 V mode, the 92HD75B can correctly decode BITCLK, SYNC, RESET# and SDO because they operate at 1.5 V. Additionally, it will drive SDI_CODEC at 1.5 V. None of the GPIOs are affected, as they always function at their nominal voltage (DVDD or AVDD).

1.4.2. Port Functionality

Single function (Input only / output only) ports allow for the highest possible performance.

- Port A supports
 - Headphone Out
 - Line Out
- Ports B and C support
 - Line In
 - Mic with 0/10/20/30/40 dB boost
- Port D supports
 - Line Out
- Port E supports
 - Line In
 - Mic with 0/10/20/30/40 dB boost
- Port F supports (48 version only)
 - Line Out

Note⁴: 40dB boost requires using the IDT driver. When the 40dB mic boost feature is enabled, additional gain increases greater than 6dB may result in significant audio quality degradation of the microphone audio input. In particular, when the 40dB MIC boost is active, the SNR, THD+N and DC offset will significantly degrade regardless of the input signal level.

1.4.3. Port Characteristics

Ports are designed to be dedicated inputs or outputs only. Universal (Bi-directional) jacks are not supported. Port A is designed to drive a set of 32 ohm (nominal) headphones or a 10K (nominal) load with on board shunt resistance as low as 20K ohms (typical - used to maintain coupling CAP bias.) Line Level outputs are intended to drive an external 10K speaker load (nominal) and an on board shunt resistor of 20-47K (nominal). However, applications may support load impedances of 5K ohms and above. Input ports are 47K impedance (nominal) at the pin.

DAC full scale outputs and intended full scale input levels are 1V rms. Line output ports and Head-on output ports on the 92HD75B may be configured for +3dBV full scale output levels by using a vendor specific verb.

Output ports are always on to prevent pops/clicks associated with charging and discharging output coupling capacitors. This maintains proper bias on output coupling caps even in D3 as long as AVDD is available. Unused ports should be left unconnected. When updating existing designs to use 92HD75B, ensure that there are no conflicts between the output ports on 92HD75B and existing circuitry.

Table 1. Analog Output Port Behavior

AFG Power State	Output Enable	Mute	Port Behavior
D0-D2	1	0	Active - audio enabled
	1	1	Active - audio mute. Port drives silence
	0	-	Inactive -port is powered on (low output impedance) but drives silence only.
D3	-	-	Inactive (lower power) - Port keeps output coupling caps charged and has low output impedance (not necessarily the same as in D0) but consumes less power.

1.4.4. Jack Detect

Plugs inserted to a jack on Ports A, B, C, & D are detected using SENSE_A. Plugs inserted to a jack on Ports E & F are detected using SENSE_B. The following figure shows external components. All external resistors are 1%, pull up is 2.5K Ω .

Figure 3. Jack Detect

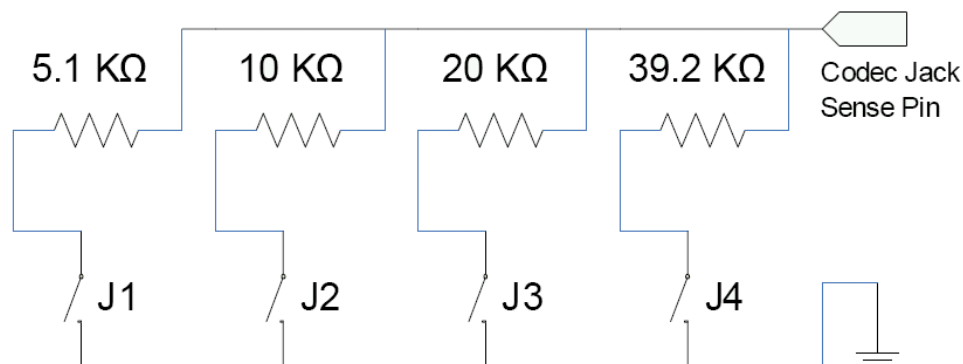

See reference design for more information on Jack Detect implementation.

1.4.5. SPDIF Output

All SPDIF Outputs can operate at 44.1kHz, 48kHz, 88.2kHz, 96kHz and 192kHz as defined in the Intel High Definition Audio Specification with resolutions up to 24 bits. This insures compatibility with

all consumer audio gear and allows for convenient integration into home theater systems and media center PCs.

A second independant SPDIF Output is provided as an option for WLP compliant HDMI and SPDIF outputs. Its function is identical to the primary SPDIF output.

Table 2. SPDIF OUT 0 (Pin 48) Behavior

AFG Power State	RESET#	Output Enable	Converter Dig Enable	Stream ID	Pin Behavior
D0-D3	Asserted (Low)	-	-	-	Hi-Z (internal pull-down enabled) immediately after power on, otherwise the previous state is retained until the rising edge of RESET#
	De-Asserted (High)	Disabled	-	-	Hi-Z (internal pull-down enabled)
	De-Asserted (High)	Enabled	Disabled	-	Active - Pin drives 0 (internal pull-down enabled)
	De-Asserted (High)	Enabled	Enabled	0	Active - Pin drives SPDIF-format, but data is zeroes (internal pull-down enabled)
	De-Asserted (High)	Enabled	Enabled	1-15	Active - Pin drives SPDIFOut0 data (internal pull-down enabled)

Table 3. SPDIF OUT 1 (Pin 45) Behavior

AFG Power State	RESET#	GPIO7 Enable	Output Enable	Converter Dig Enable	Stream ID	Pin Behavior
D0-D3	Asserted (Low)	-	-	-	-	Hi-Z (internal pull-down enabled) immediately after power on, otherwise the previous state is retained until the rising edge of RESET#
	De-Asserted (High)	Enabled	-	-	-	Active - Pin reflects GPIO7 configuration (internal pull-up enabled)
	De-Asserted (High)	Disabled	Disabled	-	-	Hi-Z (internal pull-down enabled)
	De-Asserted (High)	Disabled	Enabled	Disabled	-	Active - Pin drives 0 (internal pull-down enabled)
	De-Asserted (High)	Disabled	Enabled	Enabled	0	Active - Pin drives SPDIF-format, but data is zeroes (internal pull-down enabled)
	De-Asserted (High)	Disabled	Enabled	Enabled	1-15	Active - Pin drives SPDIFOut1 data (internal pull-down enabled)

1.4.6. **Mono Output**

The MONO Output has an independent mute (see the Widget listing for details). The MONO Output derives its input from the output of the summing node after the mono mux. The following sources are available for the mono pin:

- DAC0 Output: When enabled (by using port connection list), both DAC0 Outputs are summed together.
- DAC1 Output: When enabled (by using port connection list), both DAC1 Outputs are summed together.
- Input Mixer: When enabled (by using mono mix connection list and DAC mixer), both mixer outputs are summed together.

The stereo inputs are scaled by -6dB and then summed to provide an output that is the average of the two inputs. The full scale output at mono out is designed to be about 0dBV. It is not possible to adjust to a +3dBV output level.

Mono out and Analog PC Beep share a pin. If legacy Analog PC Beep input and mono out are required, Port E can be used as an optional Analog PC Beep Input.

1.4.7. **Input Multiplexers**

92HD75B implements 2 port input multiplexers. These multiplexers incorporate the microphone boost function (0, 10dB, 20dB, 30dB, and 40dB gain) as an output amp and allow a preselection of one of three possible inputs:

- Port B
- Port C
- Port E

NOTE: Changing the Input multiplexer setting will affect the ADC. This may present a negative user experience and must be exposed carefully to prevent problems. 40dB boost is implemented but the only 0-30dB gain steps are reported.

1.4.8. **ADC Multiplexers**

92HD75B implements 2 ADC input multiplexers. These multiplexers incorporate the ADC record gain function (0 to +22.5dB gain in 1.5dB steps) as an output amp and allow a preselection of one of four possible inputs:

- DMIC 0
- DMIC1 (48QFN package only)
- InPortMux (ADC0 selects inport0_mux / ADC1 selects inport1_mux)
- Mixer output

1.4.9. **Power Management**

The following table describes what functionality is active in each power state

The D3-default state is available for HD Audio compliance. The programmable values, exposed via vendor-specific settings, are under the IDT Device Driver control for further power reduction.

The default power state for the Audio Function Group after reset is D3-default..

Table 4. Power Managemen

D0	D1	D2 ¹	D3	vendor specific	Function
On	Off	Off	Off	-	DAC
On	Off	Off	Off	-	D2S
On	Off	Off	Off	-	ADC
On	Off	Off	Off	-	ADC Volume Control
On	Off	Off	Off	-	Ref ADC
On	Off	Off	Off	-	Analog Clocks
On	On	Off	Off	-	VrefOut Pins
On	On	Off	Off	-	Input Boost
On	On	On	Low Drive ²	Programmable	Lo Amp
On	On	On	Low Drive ²	Programmable	HP Amps
On	On	On	Low Drive ³	Programmable	VAG amp
On	On	On	On ⁴	Programmable	Port Sense
On	On	On	On	Programmable ⁵	Reference Bias generator
On	On	On	On	Programmable ⁵	Reference Bandgap core
On	On	On	On ⁶	-	AZ-Link

1.No DAC or ADC streams are active. Analog mixing and loop thru are supported.

2.VAG is kept active when ports are disabled or in D2/D3. Ports A, D, F and mono may be powered down using vendor specific verbs.

3.VAG is always ramped up and down gradually, except in the case of a sudden power removal. VAG is active in D2/D3 but in a low power state.

4. BITCLK must be active and both AVDD and DVDD must be available for Port Sense to operate.

5.Vendor specific bit for Ref Top controls VAG generator, Bandgap Reference, and Reference bias generator. Place part into D3 and power down all ports (using vendor specific verbs) before powering down Ref Top.

6.Not active if BITCLK is not running (Controller in D3).

1.4.10. Multi-channel capture

The capability to assign multiple “ADC Converters” to the same stream is supported to meet the microphone array requirements of Vista and future operating systems. Single converter streams are still supported and is done by assigning unique non zero Stream IDs to each converter. All capture devices (ADCs 0 and 1) must be used to create a multi-channel input stream. There are no restrictions regarding digital microphones.

The ADC Converters can be associated with a single stream as long the sample rate and the bits per sample are the same. The assignment of converter to channel is done using the “CnvtrID” widget and is restricted to even values. The ADC converters will always put out a stereo sample and therefore require 2 channels per converter.

The stream will not be generated unless all entries for the targeted converters are set identically, and the total number of assigned converter channels matches the value in the NmbrChan field. These are listed the “Multi-Converter Stream Critical Entries.” table.

An example of a 4 Channel Steam with ADC0 supplying channels 0&1 and ADC1 supplying channels 2 & 3 is shown below. A 4 Channel stream can be created by assigning the same non-zero stream id “Strm= N” to both ADC0 and ADC1. The sample rates must be set the same and the number of channels must be set to 4 channels “NmbrChan = 0011”.

Table 5: Example channel mapping

ADC1 CnvtrID	(NID = 0x08)	
	[3:0]	Ch = 2
ADC0 CnvtrID	(NID = 0x07)	
	[3:0]	Ch=0

Figure 4. Multi-channel capture

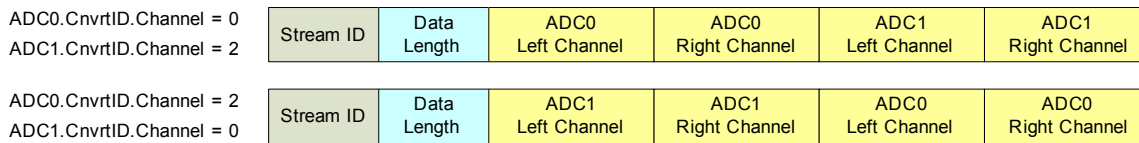

The following figure describes the bus waveform for a 24-bit, 48KHz capture stream with ID set to 1.

Figure 5. Multi-channel timing diagram

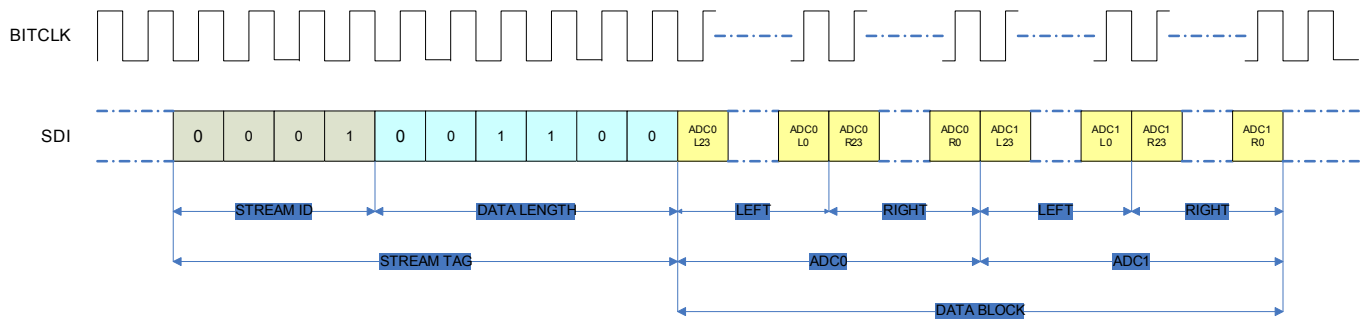

1.4.11. EAPD

The EAPD pin (pin 47) also supports SPDIF and GPIO functions. The pin defaults to EAPD after power on reset and will remain in EAPD mode until either GPIO is enabled for pin 47 or the port I/O is enabled to support SPDIF. The EAPD value is reflected on the EAPD pin; a 1 causes the external amplifier to power up, and a 0 causes it to power down. When the EAPD value = 1, the EAPD pin must be placed in a state appropriate to the current power state of the associated Pin Widget even though the EAPD value may remain 1. The default state of this pin is 0 (driving low) and a Pull-down prevents the line from floating high when the part is in reset.

Table 6. EAPD Behavior

AFG Power State	RESET#	GPIO Enable	Output Enable	EAPD Power State	Pin Behavior
D0-D3	Asserted (Low)	-	-	-	Hi-Z (internal pull-down enabled) immediately after power on, otherwise the previous state is retained until the rising edge of RESET#
	De-Asserted (High)	Enabled	-	-	Active - Pin reflects GPIO0 configuration (internal pull-up enabled)
	De-Asserted (High)	Disabled	Enabled	-	Active - Pin Drives SPDIFOut0/1 output (internal pull-down enabled)
	De-Asserted (High)	Disabled	Disabled	D2-D3	Hi-Z (internal pull-down enabled)
	De-Asserted (High)	Disabled	Disabled	D0-D1	Active - Pin drives the value of the EAPD bit (internal pull-down enabled)

1.4.12. Digital Microphone Support

The digital microphone interface permits connection of a digital microphone(s) to the CODEC via the DMIC0, DMIC1 (48QFN package only), and DMIC_CLK 3-pin interface. The DMIC0 and DMIC1 signals are inputs that carry individual channels of digital Mic data to the ADC. In the event that a single microphone is used, the data is ported to both ADC channels.

The DMIC_CLK output is controllable from 4.704Mhz, 3.528Mhz, 2.352Mhz, 1.176Mhz and is synchronous to the 24Mhz internal clock. The default frequency is 2.352Mhz.

92HD75B supports the following digital microphone configurations:

Table 7. Valid Digital Mic Configurations

Digital Mics	Data Sample	ADC Conn.	Notes
0	N/A	N/A	No Digital Microphones
1	Single Edge	0, or 1	Available on either DMIC_0 or DMIC_1 Both ADC Channels produce data, may be in phase or out by 1/2 DMIC_CLK period depending upon external configuration and timing
2	Double Edge on either DMIC_0 or 1 OR Single Edge on DMIC_0 and 1	0, or 1	Available on either DMIC_0 or DMIC_1, External logic required to support sampling on a single Digital Mic pin channel on rising edge and second Digital Mic right channel on falling edge of DMIC_CLK for those digital microphones that don't support alternative clock edge capability. If both DMIC_0 and DMIC_1 are used to support 2 digital microphones, 2 separate ADC units will be used, however, this configuration is not recommended since it consumes two stereo ADC resources.
3	Double Edge on one DMIC pin and Single Edge on the second DMIC pin.	0, or 1	Requires both DMIC_0 AND DMIC_1, External logic required to support sampling on a single Digital Mic pin channel on rising edge and second Digital Mic right channel on falling edge of DMIC_CLK for those digital microphones that don't support alternative clock edge capability. Two ADC units are required to support this configuration
4	Double Edge	0, or 1	Connected to DMIC_0 and DMIC_1, External logic required to support sampling on a single Digital Mic pin channel on rising edge and second Digital Mic right channel on falling edge of DMIC_CLK for those digital microphones that don't support alternative clock edge capability. Two ADC units are required to support this configuration

Table 8. DMIC_CLK and DMIC_0,1 Operation During Power States

Power State	DMIC Widget Enabled?	DMIC_CLK Output	DMIC_0,1	Notes
D0	Yes	Clock Capable	Input Capable	DMIC_CLK Output is Enabled when either DMIC_0 or DMIC_1 Input Widget is Enabled. Otherwise, the DMIC_CLK remains Low
D1	Yes	Clock Disabled	Input Disabled	DMIC_CLK Output is Enabled when either DMIC_0 or DMIC_1 Input Widget is Enabled. Otherwise, the DMIC_CLK remains Low
D2	Yes	Clock Disabled	Input Disabled	DMIC_CLK Remains Low
D3	Yes	Clock Disabled	Input Disabled	DMIC_CLK Remains Low
D0-D3	No	Clock Disabled	Input Disabled	DMIC_CLK is HIGH-Z with Weak Pull-down

Figure 6. Single Digital Microphone (data is ported to both left and right channels)

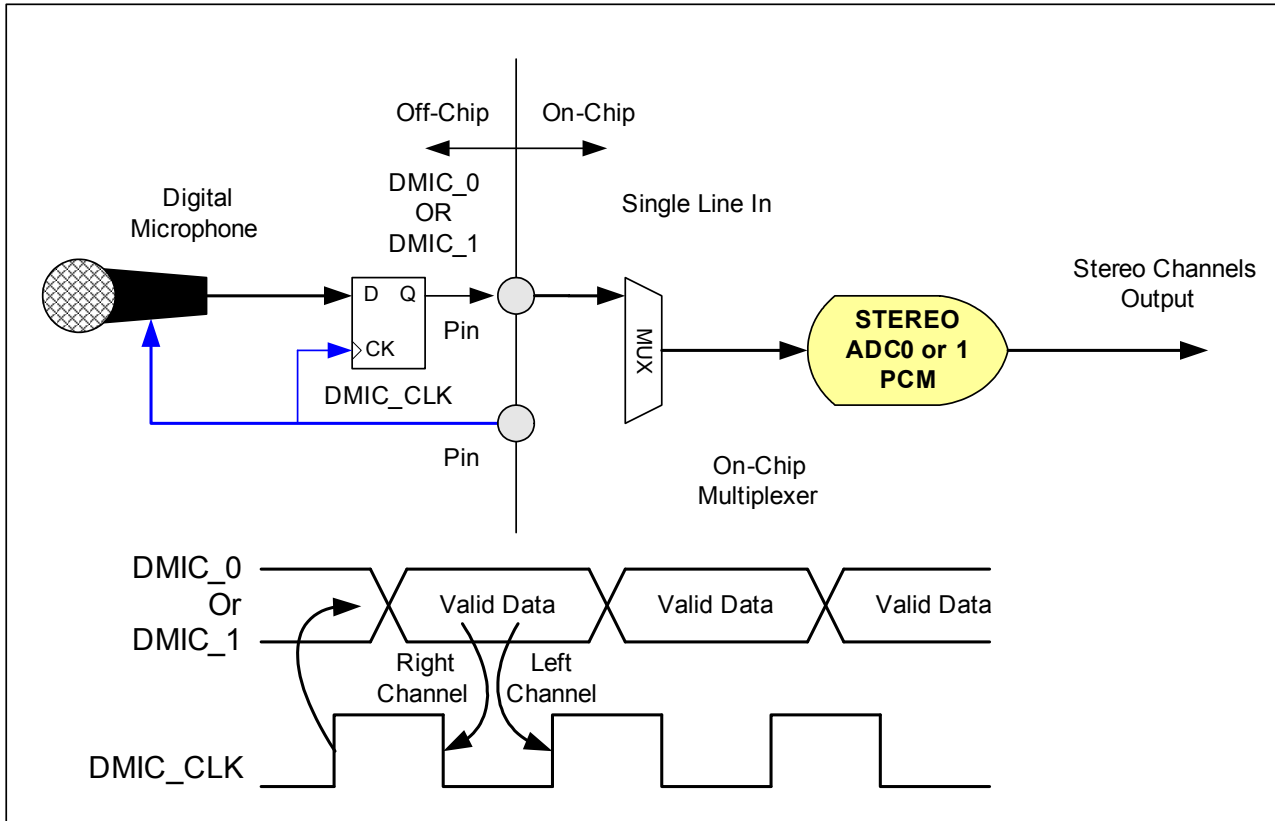
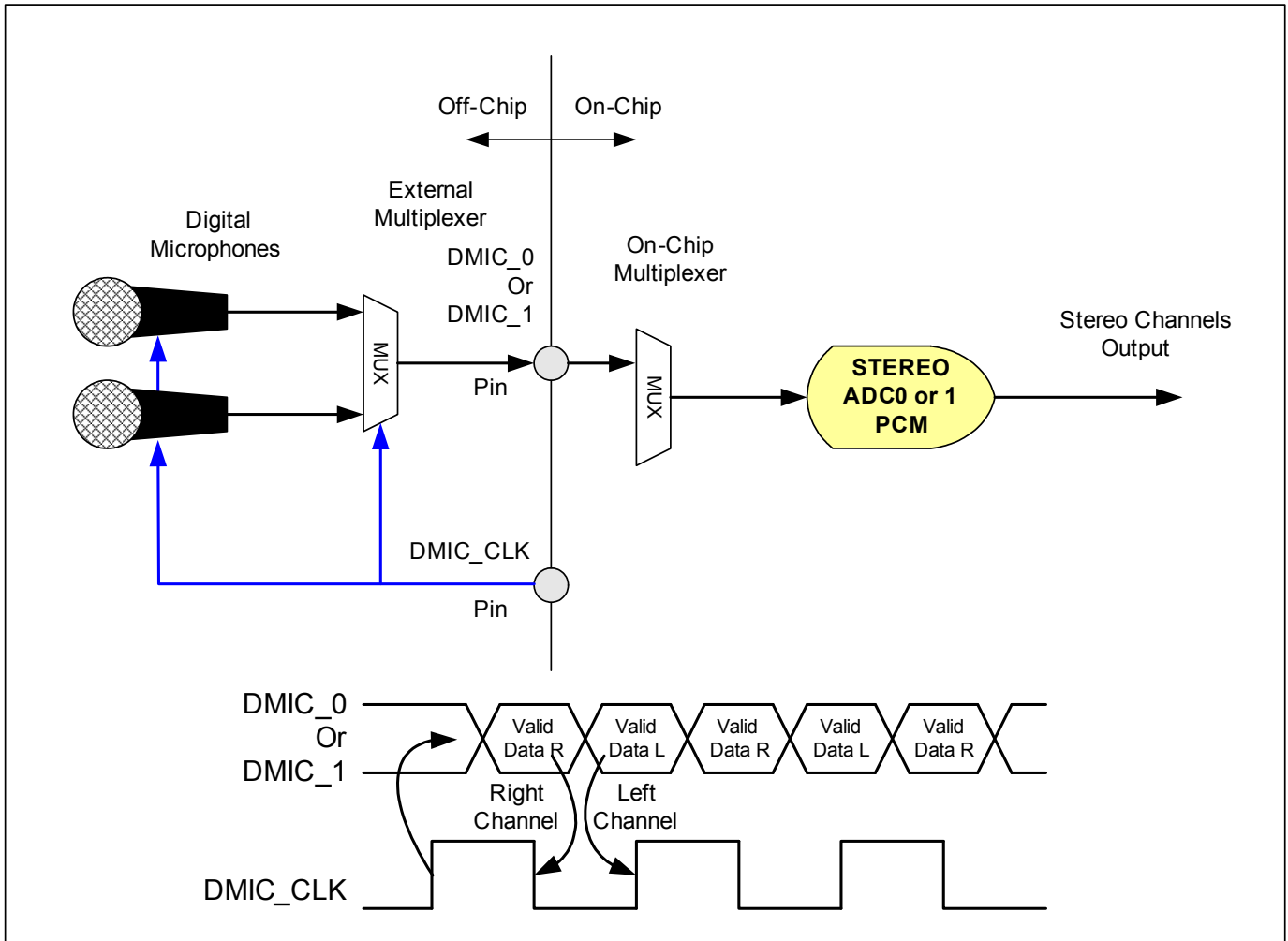
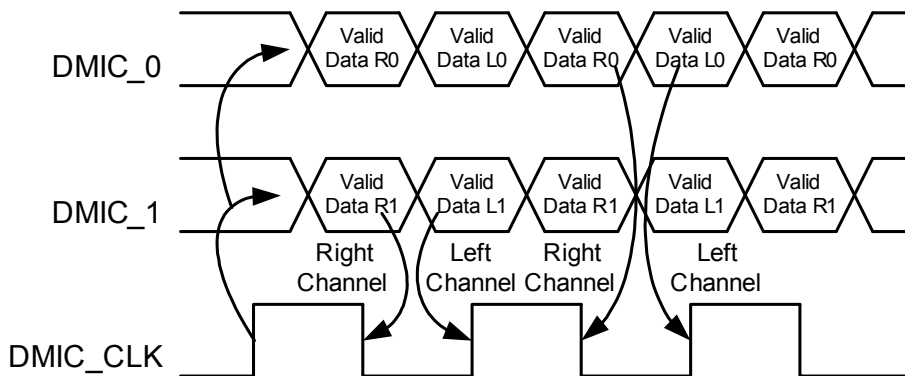
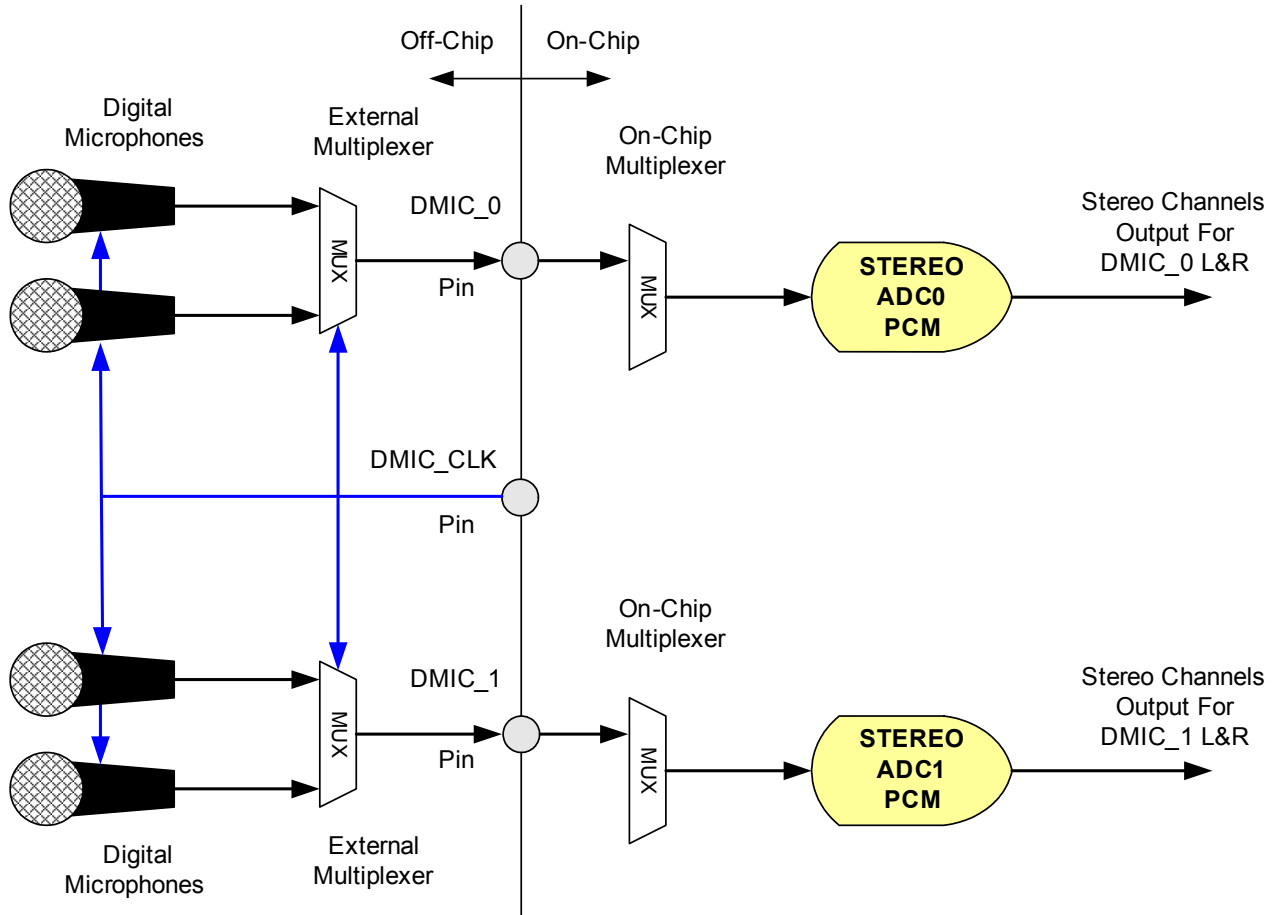

Figure 7. Stereo Digital Microphone Configuration



Note: Some Digital Microphone Implementations support data on either edge, therefore, the external mux may not be required.

Figure 8. Quad Digital Microphone Configuration



Note: Some Digital Microphone Implementations support data on either edge, therefore, the external mux may not be required.

1.4.13. Analog PC-Beep

92HD75B does not support automatic routing of the PC_Beep pin to all outputs when the link is in reset. Analog PC_BEEP is supported using a vendor specific verb.

Mono out and Analog PC Beep share a pin. If legacy Analog PC Beep input and mono out are required, Port E can be used as an optional Analog PC Beep Input.

1.4.14. Headphone Drivers

This product implements a +3dBV output option on headphone capable ports. (HP output and line output levels are defined as 1Vrms with an option to enable +3dBV FSOV using a vendor specific verb.)

1.4.15. GPIO

1.4.15.1. GPIO Pin mapping and shared functions.

Table 9. GPIO Pin mapping and shared functions

GPIO #	Supply	PKG	SPDIF Out	GPI/O	GPI	GPO	VrefOut	ADAT	DMIC	VOL	Pull Up	Pull Down
0	DVDD	32&48	YES	YES							50K (GPIO)	50K (EAPD/SPDIF)
1	DVDD	32&48		YES					YES	YES	50K (GPIO/VOL)	50K (DMIC)
2	DVDD	48	YES	YES					YES	YES	50K (GPIO/VOL)	50K (DMIC)
3	AVDD	48		YES							50K ¹	
4	AVDD	48		YES			YES					
5	DVDD	48		YES							50K ¹	
6	DVDD	48		YES							50K ¹	
7	DVDD	32&48	YES	YES							50K (GPIO)	50K (SPDIF)

1.Default condition.

1.4.15.2. Volume/Digital Microphone/GPIO Selection

To determine which function is actually enabled on pins2 and 4, the order of precedence is followed:

- 1) If the GPIOs are enabled, they override both Volume Control and Digital Mics
- 2) If the GPIOs are not enabled through the AFG, then at reset, the Volume control is enabled with the weak pull-up.
- 3) If BIOS or other software application enables either Digital Microphones inputs through the Configuration Default Register, the Volume is disconnected and the pull-ups are disconnected with the weak pull-downs enabled.

1.4.15.3. *VRefOut/GPIO Selection*

Two functions are available on pin 31. To determine which function is actually enabled, the order of precedence is followed:

- 1) If the GPIO4 function is enabled, it overrides VRefOut-E
- 2) If the GPIO4 function is not enabled through the AFG, then, at reset the VrefOut-E is enabled.
- 3) If using pin 31 as GPIO, make sure to incorporate a 10K ohm external pull-up to AVDD to prevent the pin from floating in GPI mode and to allow proper operation in open-drain GPO mode.

1.4.16. **External Volume Control (48 pad package only)**

92HD75B incorporates a 2-pin volume control interface. Volume up, down, and mute functions are easily implemented using 2 push-button switches. The CODEC provides internal pull-up resistors simplifying external CODEC circuitry. Also, repeat and direct modes of operation add flexibility to the interface. The typical usage model is for front panel master volume buttons on an entertainment PC, or case mounted hardware volume control for mobile platforms.

The external volume control is not available in the 32 pad package.

1.4.16.1. *Theory of Operation*

The codec monitors the volume up/down inputs for a change of state from high to low, and waits for the inputs to settle. If the inputs have not settled by the end of the de-bounce period, then the value at the end of the period is used. A 0 (low voltage) on the Down pin will decrement the volume register, while a 0 on the Up pin will increment the volume register. If both inputs are 0 at the same time, then the volume register will be set to its lowest value (mute). Pressing Up, Down, or both buttons at the same time when the volume control interface is in mute mode, will cause the part to un-mute.

The de-bounce / repeat rate is selectable from 2.5Hz to 20Hz in 2.5Hz increments using the Volume Knob VCSR0 verb (FE0) Rate bits (bits 2:0). This value is used for both de-bounce and repeat rates. The de-bounce period is the time that the CODEC waits for the inputs to settle, and the repeat rate is the rate at which the CODEC will increment/decrement the volume if a volume button is pushed and held. When a falling edge is detected on either one of the volume control pins, the codec will wait for (1/Rate) seconds for the input to settle. If the Continuous bit is set in the Volume Knob VCSR0 verb (bit 3), then the codec will wait for the de-bounce period to expire then repeatedly increment or decrement the volume register at the rate specified in the Rate bits until the button is released.

1.4.16.2. *Modes of Operation*

- DIRECT MODE
 - In Direct mode, the Volume Knob widget directly controls the volume of all of the DACs in the part. The volume in the Volume Knob widget acts as the master volume and limits the maximum volume for each of the DAC amplifiers. The amp gain for each of the DACs can also be adjusted using the DAC amplifiers. However, the actual gain for an individual DAC will be the sum of the Volume Knob volume and the DAC amplifier volume. For example, if the DAC amplifier gain is set to 0x7F (0dB) and the Volume Knob volume is set to 0x3F (-48dB) the resulting gain would be -48dB. If the combination of gains is less than -95.25dB (the equivalent to a value of 0x0 for the DAC or Volume Knob volume settings) then the

actual gain will be -95.25dB. For example, if the Volume Knob is set to 0x3F (-48dB) and the DAC amplifier volume is set to 0x1F (-72dB) then the DAC volume will be set to -95.25dB.

- Direct mode is enabled by setting bit 7 in the Volume Knob Cntrl verb (F0F). The volume is reflected in the Volume Knob Cntrl bits 6:0 and the step size is 0.75dB. In direct mode, software can read or write the volume in the Volume Knob widget.
- **INDIRECT MODE**
 - In indirect mode, the Volume Knob widget does not directly control the DAC amplifier gains. An event on the volume Up/Down pins will increment/decrement the value in the Volume Knob Cntrl verb (F0F) volume bits (bits 6:0) just as in Direct mode. However, instead of adjusting the DAC amplifier gain, an unsolicited response is generated (if enabled) and the control software must read the volume in the Volume Knob widget and take appropriate action. Indirect mode is particularly useful when it is undesirable to control all of the DAC amplifier volumes at the same time, or when implementing ADC volume control.
 - In indirect mode, there are only 128 volume levels in the Volume Knob Cntrl volume bits, the value will not go beyond the lower and upper limits (0x0 or 0x7F), and an unsolicited response will not be generated if an input event tries to go beyond these limits. Therefore, it is the responsibility of the controlling software to monitor the volume in the Volume Knob Widget and take appropriate action.
 - Indirect mode is enabled by clearing bit 7 in the Volume Knob Cntrl verb (F0F). The volume is reflected in the Volume Knob Cntrl bits 6:0 and the step size is 0.75dB. In direct mode, software can read or write the volume in the Volume Knob widget.

1.4.16.3. Hardware Implementation

The Volume Knob interface is comprised of two input pins, CODEC pins 2 and 4. Both pins have internal pull-up resistors, so only two push button switches are required for most implementations. Typically, a series resistor and shunt capacitor are used to help reduce noise and prevent damage from ESD and other potential faults. An example circuit is shown below.

Figure 9. Volume Knob

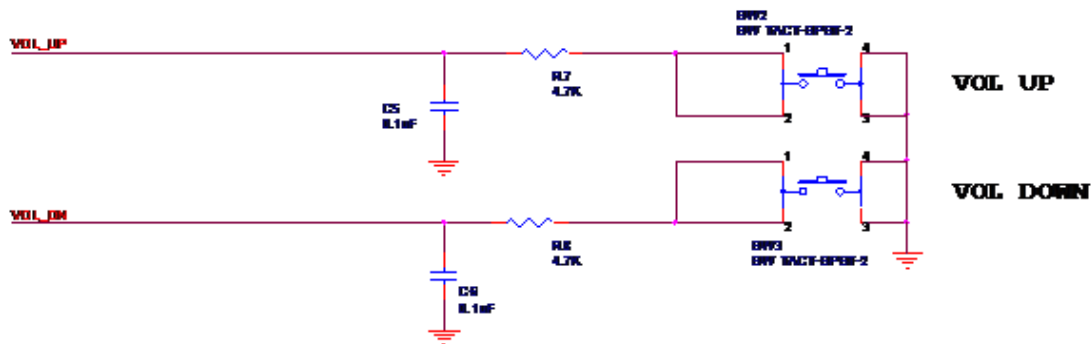

2. CHARACTERISTICS

2.1. Electrical Specifications

2.1.1. Absolute Maximum Ratings

Stresses above the ratings listed below can cause permanent damage to the 92HD75B. These ratings, which are standard values for IDT commercially rated parts, are stress ratings only. Functional operation of the device at these or any other conditions above those indicated in the operational sections of the specifications is not implied. Exposure to absolute maximum rating conditions for extended periods can affect product reliability. Electrical parameters are guaranteed only over the recommended operating temperature range.

Table 10. Electrical Specification: Maximum Ratings

Item	Pin	Maximum Rating
Analog maximum supply voltage	AVdd	6 Volts
Digital maximum supply voltage	DVdd	5.5 Volts
VREFOUT output current		5 mA
Voltage on any pin relative to ground		Vss - 0.3 V to Vdd + 0.3 V
Operating temperature		0 °C to +70 °C
Storage temperature		-55 °C to +125 °C
Soldering temperature		Soldering temperature information for all available in the package section of this datasheet.

2.1.2. Recommended Operating Conditions

Table 11. Recommended Operating Conditions

Parameter		Min.	Typ.	Max.	Units
Power Supply Voltage	Digital - Low V	1.4	1.5	1.98	V
	Digital - 3.3 V	3.135	3.3	3.465	V
	Analog - 3.3 V	3.135	3.3	3.465	V
(Note: With Supply Override Enable Bit set to force 5 V operation.)	Analog - 4 V	3.8	4	4.2	V
	Analog - 4.5 V	4.51	4.75	4.99	V
	Analog - 5 V	4.75	5	5.25	V
Ambient Operating Temperature		0		+70	°C
Case Temperature	T _{case} (32-QFN)			+95	°C
	T _{case} (48-QFN)			+95	°C

ESD: The 92HD75B is an ESD (electrostatic discharge) sensitive device. The human body and test equipment can accumulate and discharge electrostatic charges up to 4000 Volts without detection. Even though the 92HD75B implements internal ESD protection circuitry, proper ESD precautions should be followed to avoid damaging the functionality or performance.

2.2. 92HD75B 5V, 4.75V, and 3.3V Analog Performance Characteristics

(Tambient = 25 °C, AVdd = Supply ± 5%, DVdd = 3.3V ± 5%, AVss=DVss=0V; 20Hz to 20KHz swept sinusoidal input; Sample Frequency = 48 kHz; 0 dB = 1 VRMS, 10KΩ//50pF load, Testbench Characterization BW: 20 Hz – 20 kHz, 0 dB settings on all gain stages)

Table 12. 92HD75B 5V, 4.75V, and 3.3V Analog Performance Characteristics

Parameter	Conditions	AVdd	Min	Typ	Max	Unit
Digital to Analog Converters						
Resolution		All		24		Bits
Dynamic Range ¹ : PCM to All Analog Outputs	-60dB FS signal level	5V 4.75V 3.3V	93 93 93		-	dB
SNR ² - DAC to All Mono/Line-Out Ports	Analog Mixer Disabled, PCM data	5V 4.75V 3.3V	95 95 95			dB
THD+N ³ - DAC to All Mono/Line-Out Ports	Analog Mixer Disabled, 0dB FS Signal, PCM data	5V 4.75V 3.3V	83 83 83			dBr
THD+N ³ - DAC to All Mono/Line-Out Ports	Analog Mixer Disabled, -3dB FS Signal, PCM data	5V 4.75V 3.3V	83 83 83			dBr
Dynamic Range ³ : PCM to All Analog Outputs	Analog Mixer Enabled PC Beep enabled, -60dB FS signal level	5V 4.75V 3.3V	92 92 92			dB
THD+N ³ - DAC to All Mono/Line-Out Ports	Analog Mixer Enabled with Analog PC Beep enabled, 0dB FS Signal, PCM data	5V 4.75V 3.3V	81 81 81			dBr
THD+N ³ - DAC to All Mono/Line-Out Ports	Analog Mixer Enabled PC Beep enabled, -3dB FS Signal, PCM data	5V 4.75V 3.3V	81 81 81			dBr
SNR ² - DAC to All Headphone Ports	Analog Mixer Disabled, 10KΩ load, PCM data	5V 4.75V 3.3V	95 95 95			dB
THD+N ³ - DAC to All Headphone Ports	Analog Mixer Disabled, 0dB FS Signal, 10KΩ load, PCM data	5V 4.75V 3.3V	83 83 83			dBr

Table 12. 92HD75B 5V, 4.75V, and 3.3V Analog Performance Characteristics

Parameter	Conditions	AVdd	Min	Typ	Max	Unit
THD+N ³ - DAC to All Headphone Ports	Analog Mixer Disabled, -3dB FS Signal, 10K Ω load, PCM data	5V 4.75V 3.3V	83 83 83			dBr
SNR ² - DAC to All Headphone Ports	Analog Mixer Disabled, 32 Ω load, PCM data	5V 4.75V 3.3V	95 95 95			dB
THD+N ³ - DAC to All Headphone Ports	Analog Mixer Disabled, 0dB FS Signal, 32 Ω load, PCM data	5V 4.75V 3.3V	68 68 68			dBr
THD+N ³ - DAC to All Headphone Ports	Analog Mixer Disabled, -3dB FS Signal, 32 Ω load, PCM data	5V 4.75V 3.3V	68 68 68			dBr
Any Analog Input (ADC) to DAC Crosstalk	10KHz Signal Frequency	All	-65			dB
Any Analog Input (ADC) to DAC Crosstalk	1KHz Signal Frequency	All	-65			dB
DAC L/R crosstalk	DAC to LO or HP 20-15KHz into 10K Ω load	All	65			dB
DAC L/R crosstalk	DAC to HP 20-15KHz into 32 Ω load	All	65			dB
Gain Error		All			0.5	dB
Interchannel Gain Mismatch		All			0.5	dB
D/A Digital Filter Pass Band ⁴		All	20	-	21,000	Hz
D/A Digital Filter Transition Band		All	21,000	-	31,000	Hz
D/A Digital Filter Stop Band		All	31,000	-	-	Hz
D/A Digital Filter Stop Band Rejection ⁵		All	-100	-	-	dB
D/A Out-of-Band Rejection ⁶		All	-55	-	-	dB
Group Delay (48KHz sample rate)		All	-	-	1	ms
Attenuation, Gain Step Size DIGITAL		All	-	0.75	-	dB
DAC Offset Voltage		All	-	10	20	mV
Deviation from Linear Phase		All	-	10	1	deg.
Analog Outputs						
Full Scale All Line-Outs	DAC PCM Data	5V 4.75V 3.3V	1.00 1.00 0.707			Vrms
Full Scale All Line-Outs	DAC PCM Data	5V 4.75V 3.3V	2.83 2.83 2.00			Vp-p
All Headphone Capable Outputs	32 Ω load	5V 4.75V 3.3V	40 40 31		-	mW (peak)

Table 12. 92HD75B 5V, 4.75V, and 3.3V Analog Performance Characteristics

Parameter	Conditions	AVdd	Min	Typ	Max	Unit
Amplifier output impedance	Line Outputs Headphone Outputs	All		150 0.1		Ohms
External load Capacitance	Mono/Line Outputs Headphone Outputs	All			220 10,000 ⁷	pF
Analog inputs						
Full Scale Input Voltage	0dB Boost @4.75V (input voltage required for 0dB FS output)	5V 4.75V 3.3V	1.05 1.05 0.71			Vrms
All Analog Inputs with boost	10dB Boost	5V 4.75V 3.3V	0.31			Vrms
All Analog Inputs with boost	20dB Boost	5V 4.75V 3.3V	.10 0.10 0.07			Vrms
All Analog Inputs with boost	30dB Boost	5V 4.75V 3.3V	0.03			Vrms
All Analog Inputs with boost	40dB Boost	5V 4.75V 3.3V	0.01			Vrms
Boost Gain Accuracy		All	-1		1	dB
Input Impedance		All	-	50	-	KΩ
Input Capacitance		All	-	15	-	pF
Analog Mixer						
SNR ² - All Line-In to A D F & Mono Line-Outs		5V 4.75V 3.3V	85 85 85			dB
THD+N ³ - All Line-In to A D F & Mono Line-Out	0dBFS Input	5V 4.75V 3.3V	65 65 65			dBr
SNR ² - DAC to All Mono/Line-Out Ports	Analog Mixer Enabled, PCM data	5V 4.75V 3.3V	85 85 85			dB
THD+N ³ - DAC to All Mono/Line-Out Ports	Analog Mixer Enabled, 0dB FS Signal, PCM data	5V 4.75V 3.3V	75 75 75			dBr
SNR ² - DAC to All Headphone Ports	Analog Mixer Enabled, 10KΩ load, PCM data	5V 4.75V 3.3V	85 85 85			dB
THD+N ³ - DAC to All Headphone Ports	Analog Mixer Enabled, 0dB FS Signal, 10KΩ load, PCM data	5V 4.75V 3.3V	75 75 75			dBr

Table 12. 92HD75B 5V, 4.75V, and 3.3V Analog Performance Characteristics

Parameter	Conditions	AVdd	Min	Typ	Max	Unit
SNR ² - DAC to All Headphone Ports	Analog Mixer Enabled, 32Ω load, PCM data	5V 4.75V 3.3V	85 85 85			dB
THD+N ³ - DAC to All Headphone Ports	Analog Mixer Enabled, 0dB FS Signal, 32Ω load, PCM data	5V 4.75V 3.3V	60 60 60			dBr
Attenuation, Gain Step Size ANALOG		All	-	1.5		dB
Gain Drift ⁸		All	-	100		dB
Analog to Digital Converter						
Resolution		All		24		Bits
Full Scale Input Voltage	0dB Boost (input voltage required to generate 0dBFS per AES 17)	5V 4.75V 3.3V	1.05 1.05 0.71			Vrms
Dynamic Range ¹ , All Analog Inputs to A/D	High Pass Filter Enabled, -60dB FS, No boost	5V 4.75V 3.3V	86 86 82			dB
SNR ² - All Analog Inputs to A/D	High Pass Filter enabled	5V 4.75V 3.3V	86 86 82			dB
THD+N All Analog Inputs to A/D	High Pass Filter enabled, 0dB FS signal level	5V 4.75V 3.3V	78 78 78			dBr
THD+N All Analog Inputs to A/D	High Pass Filter enabled, -3dB FS signal level	5V 4.75V 3.3V	78 78 78			dBr
Analog Frequency Response ⁹		All	10	-	30,000	Hz
A/D Digital Filter Pass Band ⁴		All	20	-	21,000	Hz
A/D Digital Filter Transition Band		All	21,000	-	31,000	Hz
A/D Digital Filter Stop Band		All	31,000	-	-	Hz
A/D Digital Filter Stop Band Rejection ⁵		All	-100	-90	-	dB
Group Delay	48 KHz sample rate	All	-	-	1	ms
Any unselected analog Input to ADC Crosstalk	10KHz Signal Frequency VREF_OUT=80%, BOOST=0dB	All	-65			dB
Any unselected analog Input to ADC Crosstalk	1KHz Signal Frequency VREF_OUT=80%, BOOST=0dB	All	-65			dB
ADC L/R crosstalk	Any selected input to ADC 20-15Khz	All	-65			dB
DAC to ADC crosstalk	Any DAC output to ADC 20-15Khz VREF_OUT=80%, BOOST=0dB, 32Ω load	All	-65			dB
Spurious Tone Rejection ¹⁰		All	-	-100	-	dB

Table 12. 92HD75B 5V, 4.75V, and 3.3V Analog Performance Characteristics

Parameter	Conditions	AVdd	Min	Typ	Max	Unit
Attenuation, Gain Step Size (analog)		All	-	1.5	-	dB
Gain Drift		All	-	100	-	ppm/°C
Interchannel Gain Mismatch ADC		All	-	-	0.5	dB
40dB Mic Boost Enabled SNR	5mV Input	All		60		dB
40dB Mic Boost Enabled THD+N	5mV Input	All		55		dB
Power Supply¹¹						
Power Supply Rejection Ratio	10kHz	All	-	-60	-	dB
Power Supply Rejection Ratio	1kHz	All	-	-70	-	dB
D0 Didd ¹¹	3.3V			23		mA
D0 Aidd ¹¹	4.75V, 3.3V			70		mA
D0 Didd ¹³	3.3V			26		mA
D0 Aidd ¹³	4.75V, 3.3V			34		mA
D1 Didd	3.3V			8		mA
D1 Aidd	4.75V, 3.3V			28		mA
D2 Didd	3.3V			8		mA
D2 Aidd	4.75V, 3.3V			20		mA
D3 Didd ¹²	3.3V			6		mA
D3 Aidd ¹²	4.75V, 3.3V			9		mA
One Stereo ADC Didd	3.3V			4		mA
One Stereo ADC Aidd	4.75, 3.3V			10		mA
One Stereo DAC Didd	3.3V			4		mA
One Stereo DAC Aidd	4.75V, 3.3V			12		mA
User Digital I/O^{13,14}						
Input High Voltage (Vih)			0.6x VDD			V
Input Low Voltage (Vil)					0.35x VDD	V
Output High Voltage (Voh)	Iout = 4mA		0.9x VDD			V
Output Low Voltage (Vol)	Iout = -4mA				0.1x VDD	V
Input/Tristate High Leakage Current (Iih)	Vin = VDD			0.5		µA
Input/Tristate Low Leakage (Iol)	Vin = 0			-50		µA
Voltage Reference Outputs						
VREFOut ¹⁵		All	-	0.5 X AVdd	-	V

Table 12. 92HD75B 5V, 4.75V, and 3.3V Analog Performance Characteristics

Parameter	Conditions	AVdd	Min	Typ	Max	Unit
VREFOut Drive		All		1.6		mA
VREFILT (VAG)		All		0.45 X AVdd		V
Phased Locked Loop						
PLL lock time		All		96	200	usec
PLL (or Azalia Bit CLK) 24MHz clock jitter		All		150	500	psec
ESD / Latchup						
Latch-up	As described in JESD78A Class II	All		70		degC
ESD - Human Body Model	As described in JESD22-A114-B	All	2K	3K		V
Charged Device Model	As described in JESD22-C101	All	500	1K		V

1. Dynamic Range is the ratio of the full scale signal to the noise output with a -60dBFS signal as defined in AES17 as SNR in the presence of signal and outlined in AES6id, measured "A weighted" over 20 Hz to 20 kHz bandwidth.

2. Ratio of Full Scale signal to idle channel noise output is measured "A weighted" over a 20 Hz to a 20 kHz bandwidth. (AES17-1991 Idle Channel Noise or EIAJ CP-307 Signal-to-noise Ratio).

3. THD+N ratio as defined in AES17 and outlined in AES6id, non-weighted, over 20 Hz to 20 kHz bandwidth. Results at the jack are dependent on external components and will likely be 1 - 2dB worse.

4. Peak-to-Peak Ripple over Passband meets ± 0.125 dB limits, 48 kHz or 44.1 kHz Sample Frequency. 1dB limit.

5. Stop Band rejection determines filter requirements. Out-of-Band rejection determines audible noise.

6. The integrated Out-of-Band noise generated by the DAC process, during normal PCM audio playback, over a bandwidth 28.8 to 100 kHz, with respect to a 1 Vrms DAC output.

7. In series with 5 Ω . Maximum output capacitance is reduced to 220pF if a single pole 30kHz filter is added to attenuate conversion noise.

8. Gain drift is the change in analog volume control gain for each step across the supported 0 °C TO 70 °C temperature range referenced to the 25 °C gain value and specified in ppm per °C

9. ± 1 dB limits for Line Output & 0 dB gain, at -20dBV

10. Spurious tone rejection is tested with ADC dither enabled and compared to ADC performance without dither.

11. Everything enabled and active. Does not include 32 Ω load headphone power.

12. Idle measurement D3 set for minimum clicks/pops (biases and min. amps. on)

13. All GPIO and Digital microphone pins.

14. VDD is AVDD1 for GPIO5-7 and DVDD_CORE for others.

15. Can be set to 0.5 or 0.8 AVdd.

3. PORT CONFIGURATIONS

Figure 10. Port Configurations

32 pad package 4-port (2 out / 2 in)

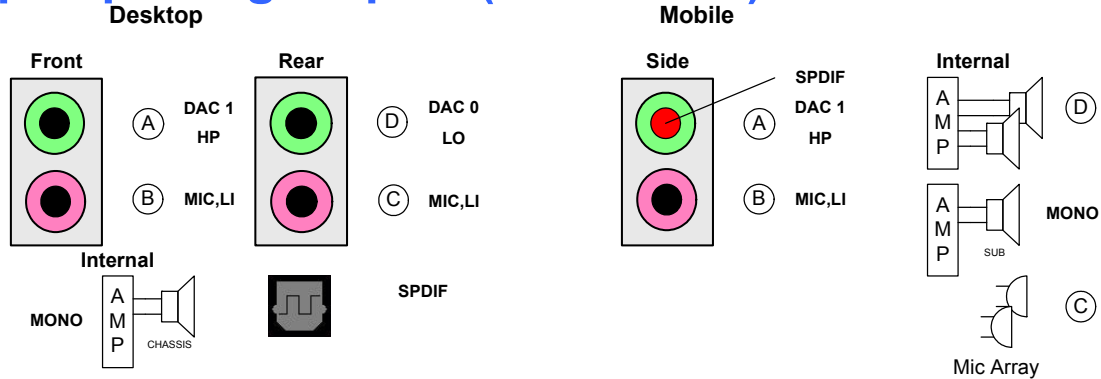

5th PORT E can be used for dock or optional Analog PC Beep input when Mono Out is used.

48 pad package 6-port (3 out / 3 in)

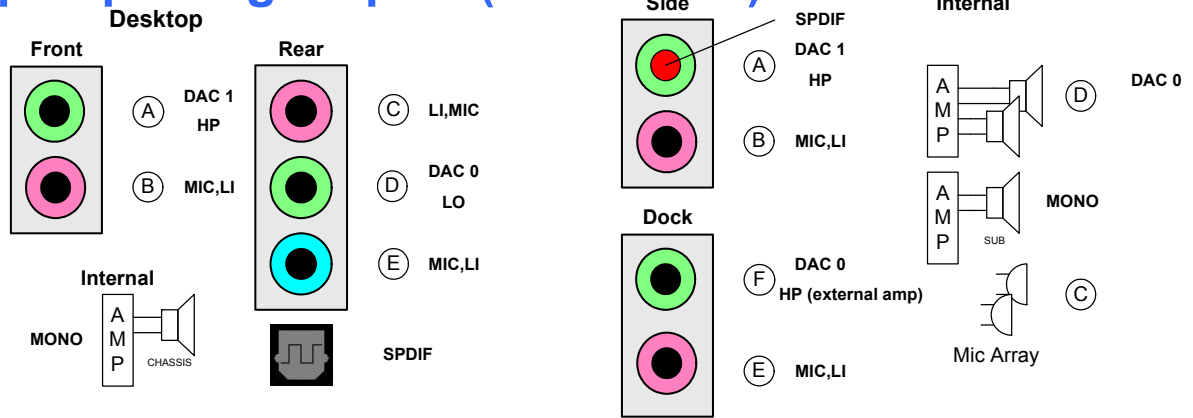

4. FUNCTIONAL BLOCK DIAGRAMS

4.1. 32 pad package, 5 port

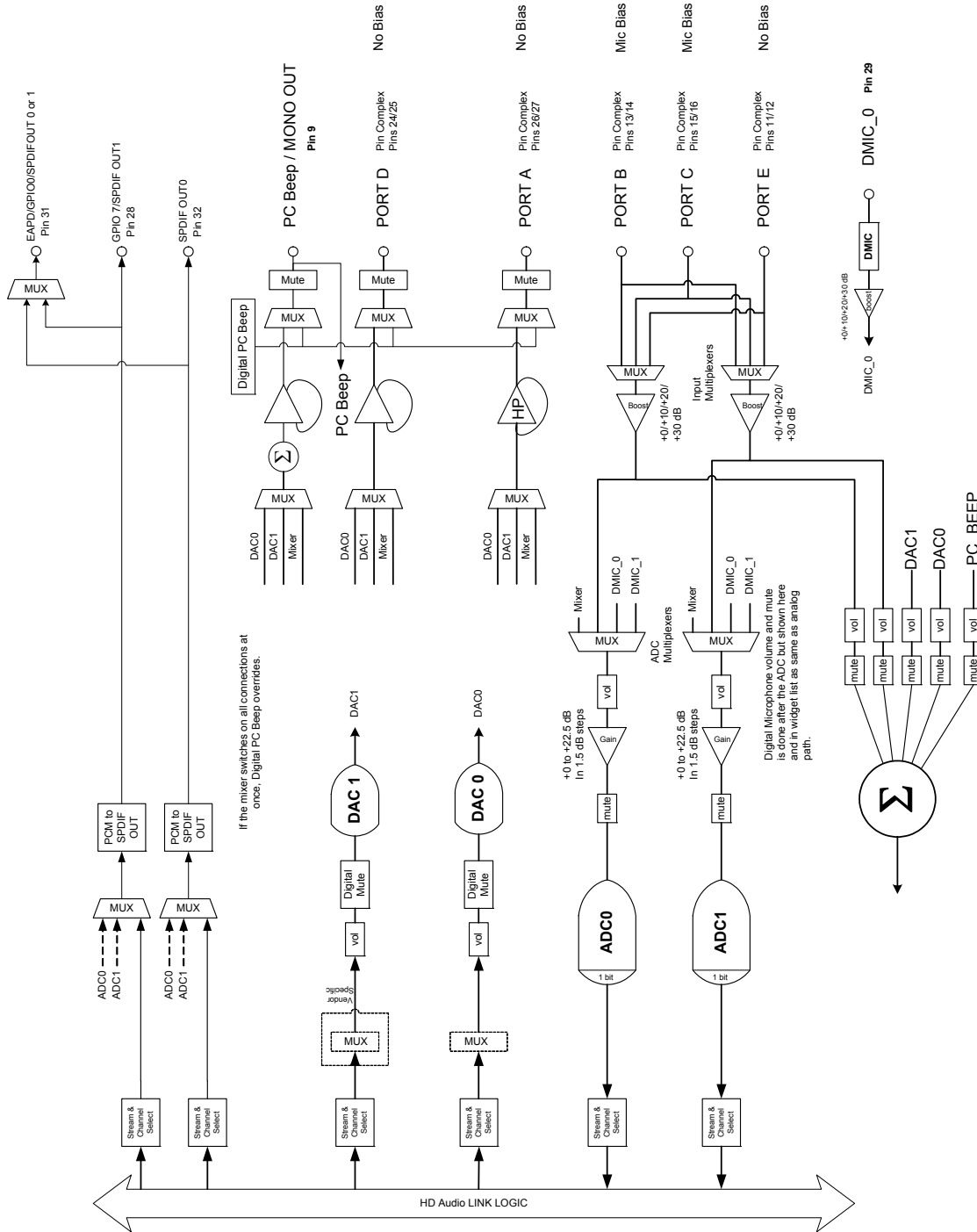

Figure 11. 92HD75B 5-port 32 pad Functional Block Diagram

4.2. 48 pad package, 6 port

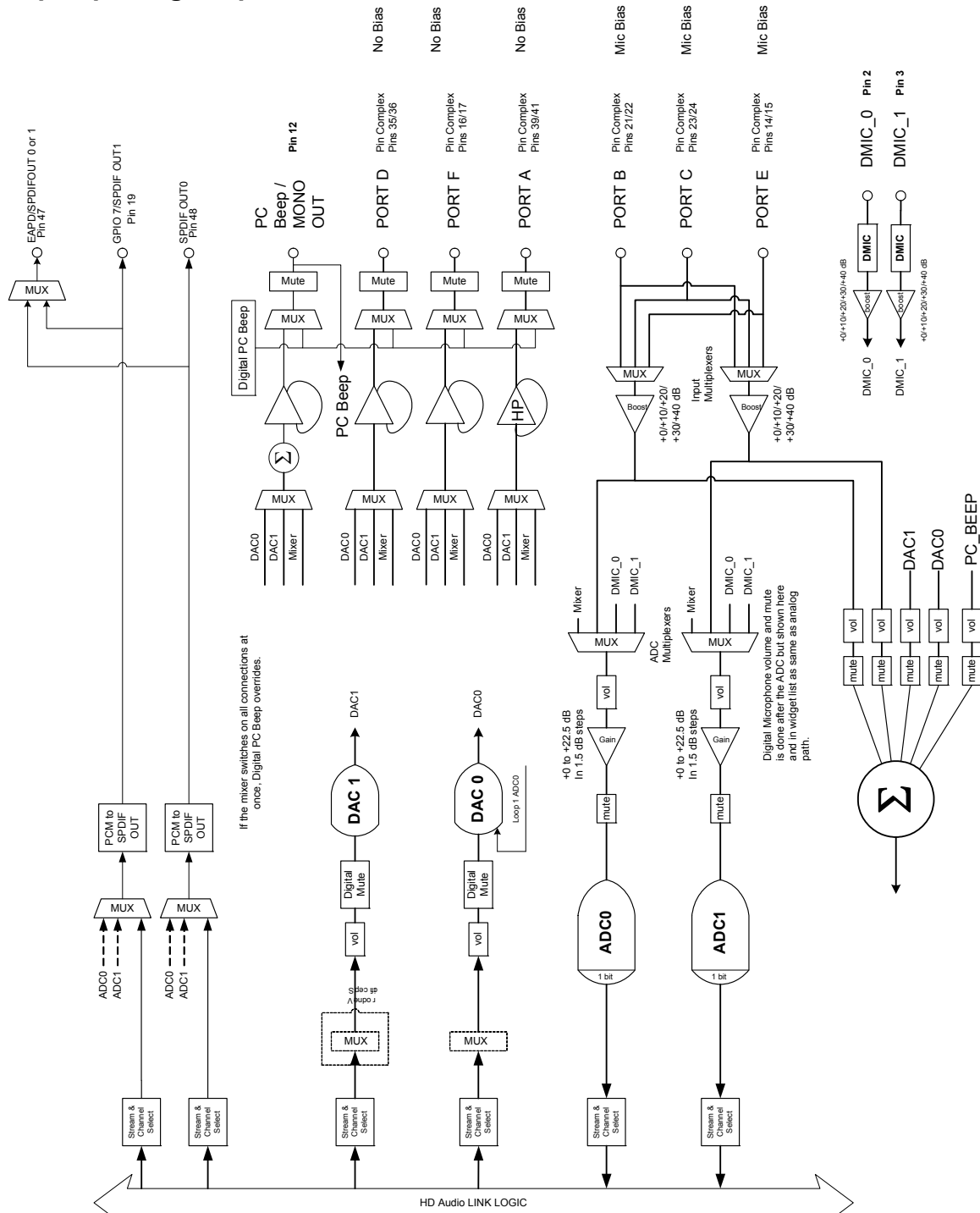

Figure 12. 92HD75B 6-port 48 pad Functional Block Diagram

5. WIDGET INFORMATION AND SUPPORTED COMMAND VERBS

5.1. 5-port 32 pad Widget Diagram

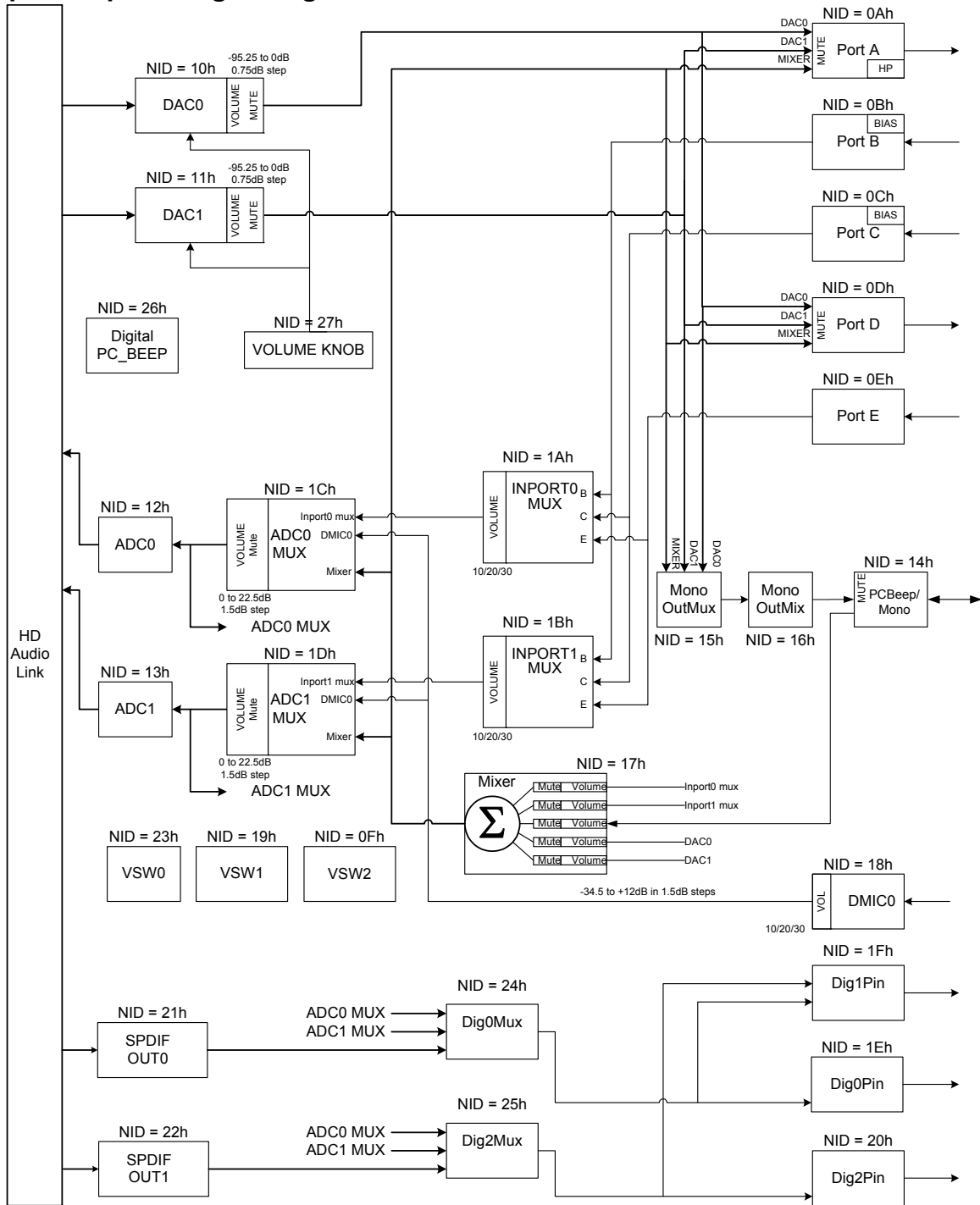

Figure 13. 92HD75B 5-port 32 pad Widget Diagram

5.2. 6-port 48 pad Widget Diagram

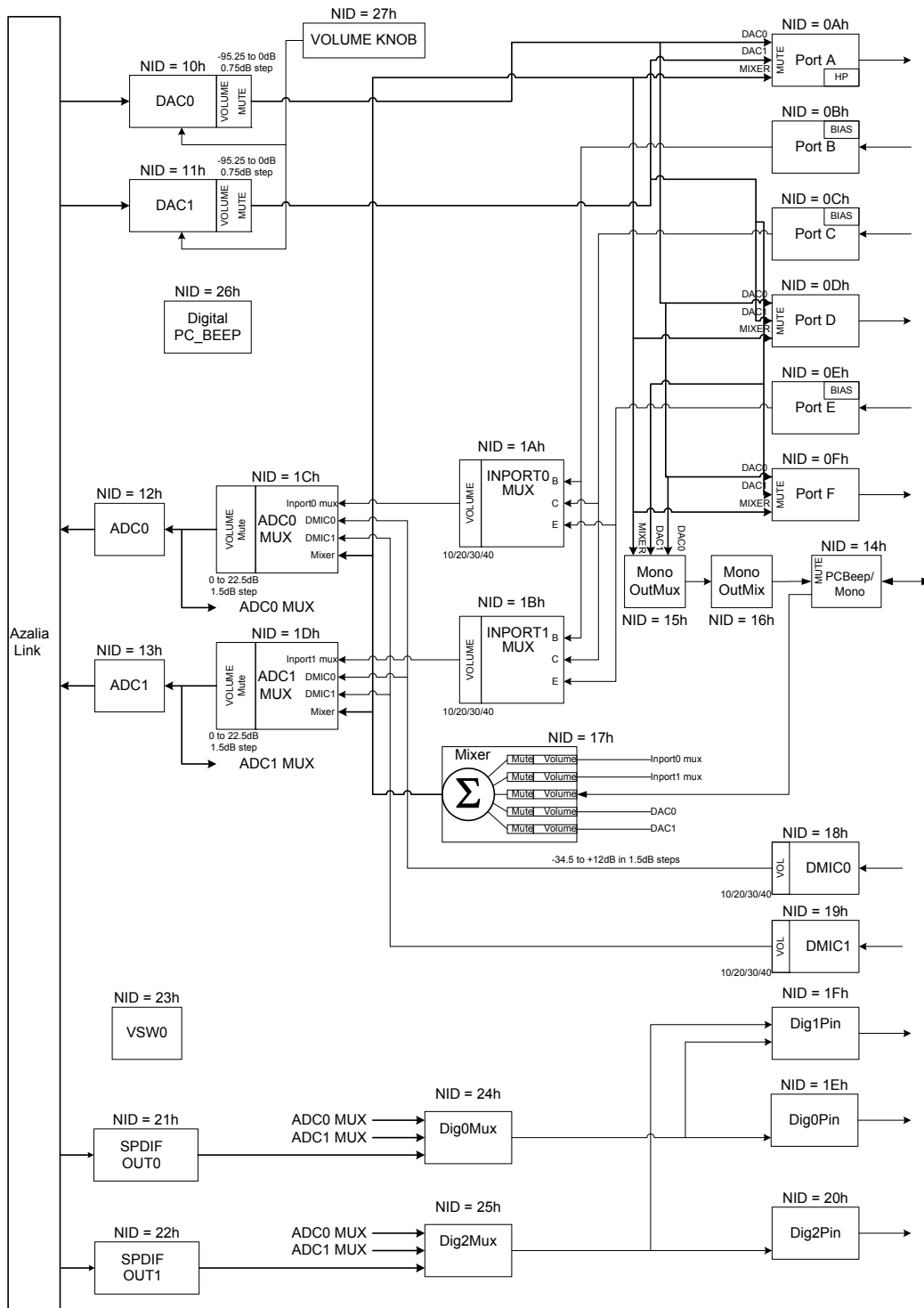

Figure 14. 92HD75B 6-port 48 pad Widget Diagram

5.3. Widget List 92HD75B

Table 13. High Definition Audio Widget

ID	Widget Name	Description
00h	Root	Root Node
01h	AFG	Audio Function Group
0Ah	Port A	Port A Pin Widget (Configurable as HP, Line Out)
0Bh	Port B	Port B Pin Widget (Configurable as Line In, Mic)
0Ch	Port C	Port C Pin Widget (Configurable as Line In, Mic)
0Dh	Port D	Port D Pin Widget (Configurable as Line Out)
0Eh	Port E	Port E Pin Widget (Configurable as Line In, Mic)
0Fh	Port F	Port F Pin Widget (Configurable as Line Out) (48QFN package only)
10h	DAC0	Stereo Output Converter to DAC
11h	DAC1	Stereo Output Converter to DAC
12h	ADC0	Stereo Input Converter to ADC
13h	ADC1	Stereo Input Converter to ADC
14h	MonoPcBeep	Port MonoOut and Pc Beep Pin Widget
15h	MonoOutMux	Mono output source selector
16h	MonoOutMix	Port MonoOut Mixer
17h	Input Mixer	Input Mixer (Input Ports, DACs, Analog PC_Beep)
18h	DigMic0	Digital Microphone 0 Pin Widget
19h	DigMic1	Digital Microphone 1 Pin Widget (48QFN package only)
1Ah	InPort0Mux	Input port pre-select for ADC0 (also for mixer)
1Bh	InPort1Mux	input port pre-select for ADC1 (also for mixer)
1Ch	ADC0Mux	ADC0 Mux with volume and mute
1Dh	ADC1Mux	ADC1 Mux with volume and mute
1Eh	Dig0Pin	Digital Output Pin
1Fh	Dig1Pin	EAPD and tertiary Digital Output Pin
20h	Dig2Pin	Secondary Digital Output Pin
21h	SPDIFOut0	Stereo Output for SPDIF_Out
22h	SPDIFOut1	Second Stereo Output for SPDIF_Out
23h	Reserved	Reserved
24h	Dig0Mux	Digital Output mux for Dig0Pin
25h	Dig2Mux	Digital Output Mux for Dig2Pin
26h	PCBeep	Digital PC Beep
27h	Volume Knob	Analog PC Beep Input Pin

6. PIN CONFIGURATION DEFAULT REGISTER SETTINGS

The configuration default registers are 32-bit registers required for each pin widget. These registers are normally used by the CODEC driver to determine the configuration of jacks and devices attached to the CODEC. When the CODEC is powered on, these registers are loaded with the default values provided by IDT for typical system usage, and are loaded in a way that is compatible with the Microsoft Universal Audio Architecture (UAA) driver. The values can be overridden by IDT customers according to their system configuration. Table 14 shows the Pin Widget Configuration Default settings.

Table 14. Pin Configuration Default Settings

Pin Name	Port	Location	Device	Connection	Color	Misc	Assoc.	Seq
PortAPin	Connect to Jack 00b	Mainboard Front 2h	HP Out 2h	1/8 inch Jack 1h	Green 4h	Jack Detect Override=0	3h	0h
PortBPin	Connect to Jack 00b	Mainboard Front 2h	Mic In Ah	1/8 inch Jack 1h	Pink 9h	Jack Detect Override=0	4h	0h
PortCPin	Connect to Jack 00b	Mainboard Rear 1h	Mic In Ah	1/8 inch Jack 1h	Pink 9h	Jack Detect Override=0	2h	0h
PortDPin	Connect to Jack 00b	Mainboard Rear 1h	Line Out 0h	1/8 inch Jack 1h	Green 4h	Jack Detect Override=0	1h	0h
MonoOutPin	Not Connected 01b	NA 000000b	Other Fh	Unknown 0h	Unknown 0h	Jack Detect Override=0	Fh	0h
DigOutPin0	Connect to Jack 00b	Mainboard Rear 000001b	SPDIF Out 4h	optical 5h	Gray 2h	Jack Detect Override=0	5h	0h
DigOutPin1	Connect to Jack 10b	Internal 011000b	Digital Other Out 5h	Other Digital 6h	Unknown 0h	Jack Detect Override=0	6h	0h
DigOutPin2	Not Connected 01b	NA 000000b	Other Fh	Unknown 0h	Unknown 0h	Jack Detect Override=0	Fh	0h
DigMic0Pin	Not Connected 01b	NA 000000b	Other Fh	Unknown 0h	Unknown 0h	Jack Detect Override=0	Fh	0h
DigMic1Pin	Not Connected 01b	NA 000000b	Other Fh	Unknown 0h	Unknown 0h	Jack Detect Override=0	Fh	0h
Analog PC_BEEP Pin	Not Connected 01b	NA 000000b	Other Fh	Unknown 0h	Unknown 0h	Jack Detect Override=0	Fh	0h

7. WIDGET INFORMATION

Table 15. Command Format for Verb with 4-bit Identifier

Bits [39:32]	Bits [31:28]	BITS [27:20]	BITS[19:16]	BITS [15:0]
Reserved	CODEC Address	NID	Verb ID (4-bit)	Payload Data (16-bit)

Table 16. Command Format for Verb with 12-bit Identifier

Bits [39:32]	Bits [31:28]	BITS [27:20]	BITS[19:8]	BITS [7:0]
Reserved	CODEC Address	NID	Verb ID (12-bit)	Payload Data (8-bit)

There are two types of responses: Solicited and Unsolicited. Solicited responses are provided as a direct response to an issued command and will be provided in the frame immediately following the command. Unsolicited responses are provided by the CODEC independent of any command. Unsolicited responses are the result of CODEC events such as a jack insertion detection. The formats for Solicited Responses and Unsolicited Responses are shown in Tables 17 and 18 respectively. The “Tag” field in bits [31:28] of the Unsolicited Response identify the event.

Table 17. Solicited Response Format

Bit [35]	Bit [34]	BITS [33:32]	BITS[31:0]
Valid (Valid = 1)	UnSol = 0	Reserved	Response

Table 18. Unsolicited Response Format

Bit [35]	Bit [34]	BITS [33:32]	BITS[31:28]	BITS [27:0]
Valid (Valid = 1)	UnSol = 1	Reserved	Tag	Response

8. SUPPORTED VERBS AND COMMANDS

8.1. Root Node (NID = 00)

)

8.1.1. *Root VendorID*

	Verb ID	Payload	Response
Get	F00	00	See bitfield table.

8.1.1.1. *Root VendorID*

Bit	Bitfield Name	RW	Reset	Description
[31.:16]	Vendor	R	111D	Vendor ID.
[15.:8]	DeviceFix	R	76	Device IDs 92HD75B1 (1.5V) = 7608h 92HD75B2 (3.3V) = 7608h 92HD75B3 or B4 = 7603h
[7.:0]	DeviceProg	R	xx	

8.1.2. *Root RevID*

	Verb ID	Payload	Response
Get	F00	02	See bitfield table.

8.1.2.1. *Root RevID*

Bit	Bitfield Name	RW	Reset	Description
[31.:24]	Rsvd	R	00	Reserved.
[23.:20]	Major	R	1	Compliant HDAudio spec major revision.
[19.:16]	Minor	R	0	Compliant HDAudio spec minor revision
[15.:12]	RevisionFix	R	0	Vendors rev number for this device.
[11.:8]	RevisionProg	R	1	Vendors rev number for this device.
[7.:4]	SteppingFix	R	0	Vendor RevID.
[3.:0]	SteppingProg	R	1	Vendor RevID.

8.1.2.2. *Root NodeInfo*

Bit	Bitfield Name	RW	Reset	Description
[31.:24]	Rsvd2	R	00	Reserved.
[23.:16]	StartNID	R	01	Starting node number (NID) of first function group
[15.:8]	Rsvd1	R	00	Reserved.
[7.:0]	TotalNodes	R	01	Total number of nodes

8.2. AFG Node (NID = 01

)

8.2.1. *AFG Reset*

	Verb ID	Payload	Response
Get			See bitfield table.

8.2.1.1. *AFG Reset*

Bit	Bitfield Name	RW	Reset	Description
[31.:8]	Rsvd1	R	000000	Reserved.
[7.:0]	Execute	W	00	Function Reset.

8.2.2. *AFG NodeInfo*

	Verb ID	Payload	Response
Get	F00	04	See bitfield table.

8.2.2.1. *AFG NodeInfo*

Bit	Bitfield Name	RW	Reset	Description
[31.:24]	Rsvd2	R	00	Reserved.
[23.:16]	StartNID	R	0A	Starting node number for function group subordinate nodes.

8.2.2.1. *AFG NodeInfo*

Bit	Bitfield Name	RW	Reset	Description
[15..8]	Rsvd1	R	00	Reserved.
[7..0]	TotalNodes	R	1Eh	Total number of nodes.

8.2.3. *AFG FGType*

	Verb ID	Payload	Response
Get	F00	05	See bitfield table.

8.2.3.1. *AFG FGType*

Bit	Bitfield Name	RW	Reset	Description
[31..9]	Rsvd	R	000000	Reserved.
[8]	UnSol	R	1	Unsolicited response supported: 1 = yes 0 = no.
[7..0]	NodeType	R	1	Function group type: 00h = Reserved; 01h = Audio Function Group; 02h = Vendor Defined Modem Function Group; 03h-7Fh = Reserved; 80h-FFh = Vendor Defined Function Group

8.2.4. *AFG AFGCap*

	Verb ID	Payload	Response
Get	F00	08	See bitfield table.

8.2.4.1. *AFG AFGCap*

Bit	Bitfield Name	RW	Reset	Description
[31..17]	Rsvd3	R	00	Reserved.
[16]	BeepGen	R	1	Beep generator present: 1 = yes 0 = no.
[15..12]	Rsvd2	R	0	Reserved.

8.2.4.1. *AFG AFGCap*

Bit	Bitfield Name	RW	Reset	Description
[11.:8]	InputDelay	R	D	Typical latency in frames. Number of samples between when the sample is received as an analog signal at the pin and when the digital representation is transmitted on the HD Audio link.
[7.:4]	Rsvd1	R	0	Reserved.
[3.:0]	OutputDelay	R	D	Typical latency in frames. Number of samples between when the signal is received from the HD Audio link and when it appears as an analog signal at the pin.

8.2.5. *AFG PCMCap*

	Verb ID	Payload	Response
Get	F00	0A	See bitfield table.

8.2.5.1. *AFG PCMCap*

Bit	Bitfield Name	RW	Reset	Description
[31.:21]	Rsvd2	R	000	Reserved.
[20]	B32	R	0	32 bit audio format support: 1 = yes 0 = no.
[19]	B24	R	1	24 bit audio format support: 1 = yes 0 = no.
[18]	B20	R	1	20 bit audio format support: 1 = yes 0 = no.
[17]	B16	R	1	16 bit audio format support: 1 = yes 0 = no.
[16]	B8	R	0	8 bit audio format support: 1 = yes 0 = no.
[15.:12]	Rsvd1	R	0	Reserved.
[11]	R12	R	0	384kHz rate support: 1 = yes 0 = no.

8.2.5.1. *AFG PCMCap*

Bit	Bitfield Name	RW	Reset	Description
[10]	R11	R	1	192kHz rate support: 1 = yes 0 = no.
[9]	R10	R	1	176.4kHz rate support: 1 = yes 0 = no.
[8]	R9	R	1	96kHz rate support: 1 = yes 0 = no.
[7]	R8	R	1	88.2kHz rate support: 1 = yes 0 = no.
[6]	R7	R	1	48kHz rate support: 1 = yes 0 = no.
[5]	R6	R	1	44.1kHz rate support: 1 = yes 0 = no.
[4]	R5	R	0	32kHz rate support: 1 = yes 0 = no.
[3]	R4	R	0	22.05kHz rate support: 1 = yes 0 = no.
[2]	R3	R	0	16kHz rate support: 1 = yes 0 = no.
[1]	R2	R	0	11.025kHz rate support: 1 = yes 0 = no.
[0]	R1	R	0	8kHz rate support: 1 = yes 0 = no.

8.2.6. *AFG StreamCap*

	Verb ID	Payload	Response
Get	F00	0B	See bitfield table.

8.2.6.1. *AFG StreamCap*

Bit	Bitfield Name	RW	Reset	Description
[31..3]	Rsvd	R	00000000	Reserved.
[2]	AC3	R	0	AC-3 formatted data support: 1 = yes 0 = no.
[1]	Float32	R	0	Float32 formatted data support: 1 = yes 0 = no.
[0]	PCM	R	1	PCM-formatted data support: 1 = yes 0 = no.

8.2.7. AFG InAmpCap

	Verb ID	Payload	Response
Get	F00	0D	See bitfield table.

8.2.7.1. AFG InAmpCap

Bit	Bitfield Name	RW	Reset	Description
[31]	Mute	R	1	Mute support: 1 = yes 0 = no.
[30.:23]	Rsvd3	R	00	Reserved.
[22.:16]	StepSize	R	00	Size of each step in the gain range: 0 to 127 = .25dB to 32dB in .25dB steps.
[15]	Rsvd2	R	0	Reserved.
[14.:8]	NumSteps	R	00	Number of gains steps (number of possible settings - 1).
[7]	Rsvd1	R	0	Reserved.
[6.:0]	Offset	R	00	Indicates which step is 0dB

8.2.8. AFG PwrStateCap

	Verb ID	Payload	Response
Get	F00	0F	See bitfield table.

8.2.8.1. AFG PwrStateCap

Bit	Bitfield Name	RW	Reset	Description
[31.:4]	Rsvd	R	0000000	Reserved.
[3]	D3Sup	R	1	D3 power state support: 1 = yes 0 = no.
[2]	D2Sup	R	1	D2 power state support: 1 = yes 0 = no.
[1]	D1Sup	R	1	D1 power state support: 1 = yes 0 = no.
[0]	D0Sup	R	1	D0 power state support: 1 = yes 0 = no.

8.2.9. AFG GPIOCnt

	Verb ID	Payload	Response
Get	F00	11	See bitfield table.

8.2.9.1. AFG GPIOCnt

Bit	Bitfield Name	RW	Reset	Description
[31]	GPIWake	R	1	Wake capability. Assuming the Wake Enable Mask controls are enabled GPIOs configured as inputs can cause a wake (generate a Status Change event on the link) when there is a change in level on the pin.
[30]	GPIUnsol	R	1	GPIO unsolicited response support: 1 = yes 0 = no.
[29.:24]	Rsvd	R	00	Reserved.
[23.:16]	NumGPIs	R	00	Number of GPI pins supported by function group.
[15.:8]	NumGPOs	R	00	Number of GPO pins supported by function group.
[7.:0]	NumGPIOs	R	08	Number of GPIO pins supported by function group.

8.2.10. AFG OutAmpCap

	Verb ID	Payload	Response
Get	F00	12	See bitfield table.

8.2.10.1. AFG OutAmpCap

Bit	Bitfield Name	RW	Reset	Description
[31]	Mute	R	1	Mute support: 1 = yes 0 = no.
[30.:23]	Rsvd3	R	00	Reserved.

8.2.10.1. AFG OutAmpCap

Bit	Bitfield Name	RW	Reset	Description
[22..16]	StepSize	R	02	Size of each step in the gain range: 0 to 127 = .25dB to 32dB in .25dB steps.
[15]	Rsvd2	R	0	Reserved.
[14..8]	NumSteps	R	7F	Number of gains steps (number of possible settings - 1).
[7]	Rsvd1	R	0	Reserved.
[6..0]	Offset	R	7F	Indicates which step is 0dB

8.2.11. AFG PwrState

	Verb ID	Payload	Response
Get	F05	00	See bitfield table.

8.2.11.1. AFG PwrState

Bit	Bitfield Name	RW	Reset	Description
[31..6]	Rsvd2	R	0000000	Reserved.
[5..4]	Act	R	3	Actual power state of this widget.
[3..2]	Rsvd1	R	0	Reserved.
[1..0]	Set	RW	3	Current power state setting for this widget.

8.2.12. AFG UnsolResp

	Verb ID	Payload	Response
Get	F08	00	See bitfield table.

8.2.12.1. AFG UnsolResp

Bit	Bitfield Name	RW	Reset	Description
[31..8]	Rsvd2	R	000000	Reserved.
[7]	En	RW	0	Unsolicited response enable: 1 = enabled 0 = disabled.
[6]	Rsvd1	R	0	Reserved.
[5..0]	Tag	RW	00	Software programmable field returned in top six bits (31:26) of every Unsolicited Response generated by this node.

8.2.13. AFG GPIO

	Verb ID	Payload	Response
Get	F15	00	See bitfield table.

8.2.13.1. AFG GPIO

Bit	Bitfield Name	RW	Reset	Description
[31..8]	Rsvd	R	000000	Reserved.
[7]	Data7	RW	0	Data for GPIO7. If this GPIO bit is configured as Sticky (edge-sensitive) input it can be cleared by writing "0". For details of read back value refer to HD Audio spec. section 7.3.3.22
[6]	Data6	RW	0	Data for GPIO6. If this GPIO bit is configured as Sticky (edge-sensitive) input it can be cleared by writing "0". For details of read back value refer to HD Audio spec. section 7.3.3.22
[5]	Data5	RW	0	Data for GPIO5. If this GPIO bit is configured as Sticky (edge-sensitive) input it can be cleared by writing "0". For details of read back value refer to HD Audio spec. section 7.3.3.22

8.2.13.1. AFG GPIO

Bit	Bitfield Name	RW	Reset	Description
[4]	Data4	RW	0	Data for GPIO4. If this GPIO bit is configured as Sticky (edge-sensitive) input it can be cleared by writing "0". For details of read back value refer to HD Audio spec. section 7.3.3.22
[3]	Data3	RW	0	Data for GPIO3. If this GPIO bit is configured as Sticky (edge-sensitive) input it can be cleared by writing "0". For details of read back value refer to HD Audio spec. section 7.3.3.22
[2]	Data2	RW	0	Data for GPIO2. If this GPIO bit is configured as Sticky (edge-sensitive) input it can be cleared by writing "0". For details of read back value refer to HD Audio spec. section 7.3.3.22
[1]	Data1	RW	0	Data for GPIO1. If this GPIO bit is configured as Sticky (edge-sensitive) input it can be cleared by writing "0". For details of read back value refer to HD Audio spec. section 7.3.3.22
[0]	Data0	RW	0	Data for GPIO0. If this GPIO bit is configured as Sticky (edge-sensitive) input it can be cleared by writing "0". For details of read back value refer to HD Audio spec. section 7.3.3.22

8.2.14. AFG GPIOEn

	Verb ID	Payload	Response
Get	F16	00	See bitfield table.

8.2.14.1. AFG GPIOEn

Bit	Bitfield Name	RW	Reset	Description
[31..8]	Rsvd	R	000000	Reserved.
[7]	Mask7	RW	0	Enable for GPIO7: 0 = pin is disabled (Hi-Z state); 1 = pin is enabled; behavior determined by GPIO Direction control
[6]	Mask6	RW	0	Enable for GPIO6: 0 = pin is disabled (Hi-Z state); 1 = pin is enabled; behavior determined by GPIO Direction control
[5]	Mask5	RW	0	Enable for GPIO5: 0 = pin is disabled (Hi-Z state); 1 = pin is enabled; behavior determined by GPIO Direction control
[4]	Mask4	RW	0	Enable for GPIO4: 0 = pin is disabled (Hi-Z state); 1 = pin is enabled; behavior determined by GPIO Direction control
[3]	Mask3	RW	0	Enable for GPIO3: 0 = pin is disabled (Hi-Z state); 1 = pin is enabled; behavior determined by GPIO Direction control
[2]	Mask2	RW	0	Enable for GPIO2: 0 = pin is disabled (Hi-Z state); 1 = pin is enabled; behavior determined by GPIO Direction control
[1]	Mask1	RW	0	Enable for GPIO1: 0 = pin is disabled (Hi-Z state); 1 = pin is enabled; behavior determined by GPIO Direction control
[0]	Mask0	RW	0	Enable for GPIO0: 0 = pin is disabled (Hi-Z state); 1 = pin is enabled; behavior determined by GPIO Direction control

8.2.15. AFG GPIODir

	Verb ID	Payload	Response
Get	F17	00	See bitfield table.

8.2.15.1. *AFG GPIODir*

Bit	Bitfield Name	RW	Reset	Description
[31..8]	Rsvd	R	000000	Reserved.
[7]	Control7	RW	0	Direction control for GPIO7: 0 = GPIO is configured as input; 1 = GPIO is configured as output
[6]	Control6	RW	0	Direction control for GPIO6: 0 = GPIO is configured as input; 1 = GPIO is configured as output
[5]	Control5	RW	0	Direction control for GPIO5: 0 = GPIO is configured as input; 1 = GPIO is configured as output
[4]	Control4	RW	0	Direction control for GPIO4: 0 = GPIO is configured as input; 1 = GPIO is configured as output
[3]	Control3	RW	0	Direction control for GPIO3: 0 = GPIO is configured as input; 1 = GPIO is configured as output
[2]	Control2	RW	0	Direction control for GPIO2: 0 = GPIO is configured as input; 1 = GPIO is configured as output
[1]	Control1	RW	0	Direction control for GPIO1: 0 = GPIO is configured as input; 1 = GPIO is configured as output
[0]	Control0	RW	0	Direction control for GPIO0: 0 = GPIO is configured as input; 1 = GPIO is configured as output

8.2.16. *AFG GPIOWakeEn*

	Verb ID	Payload	Response
Get	F18	00	See bitfield table.

8.2.16.1. AFG GPIOWakeEn

Bit	Bitfield Name	RW	Reset	Description
[31..8]	Rsvd	R	000000	Reserved.
[7]	W7	RW	0	Wake enable for GPIO7: 0 = wake-up event is disabled; 1 = When HD Audio link is powered down (RST# is asserted) a wake-up event will trigger a Status Change Request event on the link.
[6]	W6	RW	0	Wake enable for GPIO6: 0 = wake-up event is disabled; 1 = When HD Audio link is powered down (RST# is asserted) a wake-up event will trigger a Status Change Request event on the link.
[5]	W5	RW	0	Wake enable for GPIO5: 0 = wake-up event is disabled; 1 = When HD Audio link is powered down (RST# is asserted) a wake-up event will trigger a Status Change Request event on the link.
[4]	W4	RW	0	Wake enable for GPIO4: 0 = wake-up event is disabled; 1 = When HD Audio link is powered down (RST# is asserted) a wake-up event will trigger a Status Change Request event on the link.
[3]	W3	RW	0	Wake enable for GPIO3: 0 = wake-up event is disabled; 1 = When HD Audio link is powered down (RST# is asserted) a wake-up event will trigger a Status Change Request event on the link.
[2]	W2	RW	0	Wake enable for GPIO2: 0 = wake-up event is disabled; 1 = When HD Audio link is powered down (RST# is asserted) a wake-up event will trigger a Status Change Request event on the link.

8.2.16.1. AFG GPIOWakeEn

Bit	Bitfield Name	RW	Reset	Description
[1]	W1	RW	0	Wake enable for GPIO1: 0 = wake-up event is disabled; 1 = When HD Audio link is powered down (RST# is asserted) a wake-up event will trigger a Status Change Request event on the link.
[0]	W0	RW	0	Wake enable for GPIO0: 0 = wake-up event is disabled; 1 = When HD Audio link is powered down (RST# is asserted) a wake-up event will trigger a Status Change Request event on the link.

8.2.17. AFG GPIOUnsol

	Verb ID	Payload	Response
Get	F19	00	See bitfield table.

8.2.17.1. AFG GPIOUnsol

Bit	Bitfield Name	RW	Reset	Description
[31..8]	Rsvd	R	000000	Reserved.
[7]	EnMask7	RW	0	Unsolicited enable mask for GPIO7. If set and the Unsolicited Response control for this widget has been enabled an unsolicited response will be sent when GPIO2 is configured as input and changes state.
[6]	EnMask6	RW	0	Unsolicited enable mask for GPIO6. If set and the Unsolicited Response control for this widget has been enabled an unsolicited response will be sent when GPIO2 is configured as input and changes state.

8.2.17.1. AFG GPIOUnsol

Bit	Bitfield Name	RW	Reset	Description
[5]	EnMask5	RW	0	Unsolicited enable mask for GPIO5. If set and the Unsolicited Response control for this widget has been enabled an unsolicited response will be sent when GPIO2 is configured as input and changes state.
[4]	EnMask4	RW	0	Unsolicited enable mask for GPIO4. If set and the Unsolicited Response control for this widget has been enabled an unsolicited response will be sent when GPIO2 is configured as input and changes state.
[3]	EnMask3	RW	0	Unsolicited enable mask for GPIO3. If set and the Unsolicited Response control for this widget has been enabled an unsolicited response will be sent when GPIO2 is configured as input and changes state.
[2]	EnMask2	RW	0	Unsolicited enable mask for GPIO2. If set and the Unsolicited Response control for this widget has been enabled an unsolicited response will be sent when GPIO2 is configured as input and changes state.
[1]	EnMask1	RW	0	Unsolicited enable mask for GPIO1. If set and the Unsolicited Response control for this widget has been enabled an unsolicited response will be sent when GPIO1 is configured as input and changes state.
[0]	EnMask0	RW	0	Unsolicited enable mask for GPIO0. If set and the Unsolicited Response control for this widget has been enabled an unsolicited response will be sent when GPIO0 is configured as input and changes state.

8.2.18. AFG GPIOSticky

	Verb ID	Payload	Response
Get	F1A	00	See bitfield table.

8.2.18.1. AFG GPIOSticky

Bit	Bitfield Name	RW	Reset	Description
[31..8]	Rsvd	R	000000	Reserved.
[7]	Mask7	RW	0	GPIO7 input type (when configured as input): 0 = Non-Sticky (level-sensitive); 1 = Sticky (edge-sensitive).
[6]	Mask6	RW	0	GPIO6 input type (when configured as input): 0 = Non-Sticky (level-sensitive); 1 = Sticky (edge-sensitive).
[5]	Mask5	RW	0	GPIO5 input type (when configured as input): 0 = Non-Sticky (level-sensitive); 1 = Sticky (edge-sensitive).
[4]	Mask4	RW	0	GPIO4 input type (when configured as input): 0 = Non-Sticky (level-sensitive); 1 = Sticky (edge-sensitive).
[3]	Mask3	RW	0	GPIO3 input type (when configured as input): 0 = Non-Sticky (level-sensitive); 1 = Sticky (edge-sensitive).
[2]	Mask2	RW	0	GPIO2 input type (when configured as input): 0 = Non-Sticky (level-sensitive); 1 = Sticky (edge-sensitive).
[1]	Mask1	RW	0	GPIO1 input type (when configured as input): 0 = Non-Sticky (level-sensitive); 1 = Sticky (edge-sensitive).
[0]	Mask0	RW	0	GPIO0 input type (when configured as input): 0 = Non-Sticky (level-sensitive); 1 = Sticky (edge-sensitive).

8.2.19. AFG SubID

	Verb ID	Payload	Response
Get	F20	00	See bitfield table.

8.2.19.1. AFG SubID

Bit	Bitfield Name	RW	Reset	Description
[31..24]	Subsys3	RW	00	Subsystem ID (byte 3)
[23..16]	Subsys2	RW	00	Subsystem ID (byte 2)
[15..8]	Subsys1	RW	01	Subsystem ID (byte 1)
[7..0]	Assembly	RW	00	Assembly ID (Not applicable to codec vendors).

8.2.20. AFG GPIOIrty

	Verb ID	Payload	Response
Get	F70	00	See bitfield table.

8.2.20.1. AFG GPIOIrty

Bit	Bitfield Name	RW	Reset	Description
[31..8]	Rsvd	R	000000	Reserved.
[7]	GP7	RW	1	GPIO7 Polarity: If configured as output or non-sticky input: 0 = inverting; 1 = non-inverting. If configured as sticky input: 0 = falling edges will be detected; 1 = rising edges will be detected
[6]	GP6	RW	1	GPIO6 Polarity: If configured as output or non-sticky input: 0 = inverting; 1 = non-inverting. If configured as sticky input: 0 = falling edges will be detected; 1 = rising edges will be detected

8.2.20.1. AFG GPIOIrty

Bit	Bitfield Name	RW	Reset	Description
[5]	GP5	RW	1	GPIO5 Polarity: If configured as output or non-sticky input: 0 = inverting; 1 = non-inverting. If configured as sticky input: 0 = falling edges will be detected; 1 = rising edges will be detected
[4]	GP4	RW	1	GPIO4 Polarity: If configured as output or non-sticky input: 0 = inverting; 1 = non-inverting. If configured as sticky input: 0 = falling edges will be detected; 1 = rising edges will be detected
[3]	GP3	RW	1	GPIO3 Polarity: If configured as output or non-sticky input: 0 = inverting; 1 = non-inverting. If configured as sticky input: 0 = falling edges will be detected; 1 = rising edges will be detected
[2]	GP2	RW	1	GPIO2 Polarity: If configured as output or non-sticky input: 0 = inverting; 1 = non-inverting. If configured as sticky input: 0 = falling edges will be detected; 1 = rising edges will be detected
[1]	GP1	RW	1	GPIO1 Polarity: If configured as output or non-sticky input: 0 = inverting; 1 = non-inverting. If configured as sticky input: 0 = falling edges will be detected; 1 = rising edges will be detected
[0]	GP0	RW	1	GPIO0 Polarity: If configured as output or non-sticky input: 0 = inverting; 1 = non-inverting. If configured as sticky input: 0 = falling edges will be detected; 1 = rising edges will be detected

8.2.21. AFG GPIODrive

	Verb ID	Payload	Response
Get	F71	00	See bitfield table.

8.2.21.1. AFG GPIO Drive

Bit	Bitfield Name	RW	Reset	Description
[31..8]	Rsvd	R	000000	Reserved.
[7]	OD7	RW	0	GPIO7 Drive Mode: 0 = push-pull (drive 0 and 1); 1 = open drain (drive 0 float for 1).
[6]	OD6	RW	0	GPIO6 Drive Mode: 0 = push-pull (drive 0 and 1); 1 = open drain (drive 0 float for 1).
[5]	OD5	RW	0	GPIO5 Drive Mode: 0 = push-pull (drive 0 and 1); 1 = open drain (drive 0 float for 1).
[4]	OD4	RW	0	GPIO4 Drive Mode: 0 = push-pull (drive 0 and 1); 1 = open drain (drive 0 float for 1).
[3]	OD3	RW	0	GPIO3 Drive Mode: 0 = push-pull (drive 0 and 1); 1 = open drain (drive 0 float for 1).
[2]	OD2	RW	0	GPIO2 Drive Mode: 0 = push-pull (drive 0 and 1); 1 = open drain (drive 0 float for 1).
[1]	OD1	RW	0	GPIO1 Drive Mode: 0 = push-pull (drive 0 and 1); 1 = open drain (drive 0 float for 1).
[0]	OD0	RW	0	GPIO0 Drive Mode: 0 = push-pull (drive 0 and 1); 1 = open-drain (drive 0 float for 1).

8.2.22. AFG DMic

	Verb ID	Payload	Response
Get	F78	00	See bitfield table.

8.2.22.1. AFG DMic

Bit	Bitfield Name	RW	Reset	Description
[31..6]	Rsvd	R	0000000	Reserved.
[5]	Mono1	RW	0	DMic1 mono select: 0 = stereo operation, 1 = mono operation(left channel duplicated to the right channel).
[4]	Mono0	RW	0	DMic0 mono select: 0 = stereo operation, 1 = mono operation(left channel duplicated to the right channel)
[3..2]	PhAdj	RW	0	Selects what phase of the DMic clock the data should be latched: 0h = left data rising edge/right data falling edge; 1h = left data center of high/right data center of low; 2h = left data falling edge/right data rising edge; 3h = left data center of low/right data center of high
[1..0]	Rate	RW	2	Selects the DMic clock rate: 0h = 4.704MHz; 1h = 3.528MHz; 2h = 2.352MHz; 3h = 1.176MHz.

8.2.23. AFG Misc.

	Verb ID	Payload	Response
Get	F7F	00	See bitfield table.

8.2.23.1. AFG Misc.

Bit	Bitfield Name	RW	Reset	Description
[31..11]	Rsvd2	R	0000000	Reserved.
[10]	DMic1Mono	RW	0	Enable Mono Mode for DMIC1 0=disable, 1=enable mono mode
[9]	DMic0Mono	RW	0	Enable Mono Mode for DMIC0 0=disable, 1=enable mono mode

8.2.23.1. *AFG Misc.*

Bit	Bitfield Name	RW	Reset	Description
[8]	DMicSelect	RW	0	Digital Mic Select 0=DMic uses external pins 1=Volume knob uses external pins
[7..0]	Rsvd1	R	0000000	Reserved.

8.3. Port A Node (NID = 0A)

8.3.1. *PortA WCap*

	Verb ID	Payload	Response
Get	F00	09	See bitfield table.

8.3.1.1. *PortA WCap*

Bit	Bitfield Name	RW	Reset	Description
[31..24]	Rsvd2	R	00	Reserved.
[23..20]	Type	R	4	Widget type: 0h = Out Converter; 1h = In Converter; 2h = Summing (Mixer); 3h = Selector (Mux); 4h = Pin Complex; 5h = Power; 6h = Volume Knob; 7h = Beep Generator; 8h-Eh = Reserved; Fh = Vendor Defined
[19..16]	Delay	R	0	Number of sample delays through widget.
[15..12]	Rsvd1	R	0	Reserved.
[11]	SwapCap	R	0	Left/right swap support: 1 = yes 0 = no.
[10]	PwrCntrl	R	0	Power state support: 1 = yes 0 = no.
[9]	Dig	R	0	Digital stream support: 1 = yes (digital) 0 = no (analog).
[8]	ConnList	R	1	Connection list present: 1 = yes 0 = no.
[7]	UnSolCap	R	1	Unsolicited response support: 1 = yes 0 = no.

8.3.1.1. *PortA WCap*

Bit	Bitfield Name	RW	Reset	Description
[6]	ProcWidget	R	0	Processing state support: 1 = yes 0 = no.
[5]	Stripe	R	0	Striping support: 1 = yes 0 = no.
[4]	FormatOvrd	R	0	Stream format override: 1 = yes 0 = no.
[3]	AmpParOvrd	R	0	Amplifier capabilities override: 1 = yes no.
[2]	OutAmpPrsnt	R	0	Output amp present: 1 = yes 0 = no.
[1]	InAmpPrsnt	R	0	Input amp present: 1 = yes 0 = no.
[0]	Stereo	R	1	Stereo stream support: 1 = yes (stereo) 0 = no (mono).

8.3.2. *PortA PinCap*

	Verb ID	Payload	Response
Get	F00	0C	See bitfield table.

8.3.2.1. *PortA PinCap*

Bit	Bitfield Name	RW	Reset	Description
[31..17]	Rsvd2	R	0000	Reserved.
[16]	EapdCap	R	0	EAPD support: 1 = yes 0 = no.
[15..8]	VrefCntrl	R	00	Vref support: bit 7 = Reserved; bit 6 = Reserved; bit 5 = 100% support (1 = yes 0 = no); bit 4 = 80% support (1 = yes 0 = no); bit 3 = Reserved; bit 2 = GND support (1 = yes 0 = no); bit 1 = 50% support (1 = yes 0 = no); bit 0 = Hi-Z support (1 = yes 0 = no)
[7]	Rsvd1	R	0	Reserved.
[6]	BalancedIO	R	0	Balanced I/O support: 1 = yes 0 = no.

8.3.2.1. *PortA PinCap*

Bit	Bitfield Name	RW	Reset	Description
[5]	InCap	R	0	Input support: 1 = yes 0 = no.
[4]	OutCap	R	1	Output support: 1 = yes 0 = no.
[3]	HdphDrvCap	R	1	Headphone amp present: 1 = yes 0 = no.
[2]	PresDtctCap	R	1	Presence detection support: 1 = yes 0 = no.
[1]	TrigRqd	R	0	Trigger required for impedance sense: 1 = yes 0 = no.
[0]	ImpSenseCap	R	0	Impedance sense support: 1 = yes 0 = no.

8.3.3. *PortA ConLst*

	Verb ID	Payload	Response
Get	F00	0E	See bitfield table.

8.3.3.1. *PortA ConLst*

Bit	Bitfield Name	RW	Reset	Description
[31..8]	Rsvd	R	000000	Reserved.
[7]	LForm	R	0	Connection list format: 1 = long-form (15-bit) NID entries 0 = short-form (7-bit) NID entries.
[6..0]	ConL	R	03	Number of NID entries in connection list.

8.3.4. *PortA ConLstEntry0*

	Verb ID	Payload	Response
Get	F02	00	See bitfield table.

8.3.4.1. *PortA ConLstEntry0*

Bit	Bitfield Name	RW	Reset	Description
[31.:24]	ConL3	R	00	Unused list entry.
[23.:16]	ConL2	R	17	InputMixer Summing widget (0x17)
[15.:8]	ConL1	R	11	DAC1 Converter widget (0x11)
[7.:0]	ConL0	R	10	DAC0 Converter widget (0x10)

8.3.5. *PortA ConSelectCtrl*

	Verb ID	Payload	Response
Get	F01	00	See bitfield table.

8.3.5.1. *PortA ConSelectCtrl*

Bit	Bitfield Name	RW	Reset	Description
[31.:2]	Rsvd	R	00000000	Reserved.
[1.:0]	Index	RW	0	Connection select control index.

8.3.6. *PortA PinWCntrl*

	Verb ID	Payload	Response
Get	F07	00	See bitfield table.

8.3.6.1. *PortA PinWCntrl*

Bit	Bitfield Name	RW	Reset	Description
[31..8]	Rsvd2	R	000000	Reserved.
[7]	HPhnEn	RW	0	Headphone amp enable: 1 = enabled 0 = disabled.
[6]	OutEn	RW	0	Output enable: 1 = enabled 0 = disabled.
[5..0]	Rsvd1	R	0	Reserved.

8.3.7. *PortA UnsolicitedResp*

	Verb ID	Payload	Response
Get	F08	00	See bitfield table.

8.3.7.1. *PortA UnsolicitedResp*

Bit	Bitfield Name	RW	Reset	Description
[31..8]	Rsvd2	R	000000	Reserved.
[7]	En	RW	0	Unsolicited response enable: 1 = enabled 0 = disabled.
[6]	Rsvd1	R	0	Reserved.
[5..0]	Tag	RW	00	Software programmable field returned in top six bits (31:26) of every Unsolicited Response generated by this node.

8.3.8. *PortA ChSense*

	Verb ID	Payload	Response
Get	F09	00	See bitfield table.

8.3.8.1. PortA ChSense

Bit	Bitfield Name	RW	Reset	Description
[31]	PresDtct	R	0	Presence detection indicator: 1 = presence detected; 0 = presence not detected.
[30..:0]	Rsvd	R	0	Reserved.

8.3.9. PortA InAmpLeft

	Verb ID	Payload	Response
Get	B20	00	See bitfield table.

8.3.9.1. PortA InAmpLeft

Bit	Bitfield Name	RW	Reset	Description
[31..:8]	Rsvd2	R	000000	Reserved.
[7]	Mute	RW	1	Amp mute: 1 = muted 0 = not muted.
[6..:0]	Rsvd1	R	00	Reserved.

8.3.10. PortA InAmpRight

	Verb ID	Payload	Response
Get	B00	00	See bitfield table.

8.3.10.1. *PortA InAmpRight*

Bit	Bitfield Name	RW	Reset	Description
[31.:8]	Rsvd2	R	000000	Reserved.
[7]	Mute	RW	1	Amp mute: 1 = muted 0 = not muted.
[6.:0]	Rsvd1	R	00	Reserved.

8.3.11. *PortA ConfigDefault*

	Verb ID	Payload	Response
Get	F1C	00	See bitfield table.

8.3.11.1. *PortA ConfigDefault*

Bit	Bitfield Name	RW	Reset	Description
[31.:30]	PortConnectivity	RW	0	Port connectivity: 0h = Port complex is connected to a jack; 1h = No physical connection for port; 2h = Fixed function device is attached; 3h = Both jack and internal device attached (info in all other fields refers to integrated device any presence detection refers to jack)
[29.:24]	Location	RW	02	Location. Bits [5..4]: 0h = External on primary chassis; 1h = Internal; 2h = Separate chassis; 3h = Other. Bits [3..0]: 0h = N/A; 1h = Rear; 2h = Front; 3h = Left; 4h = Right; 5h = Top; 6h = Bottom; 7h-9h = Special; Ah-Fh = Reserved
[23.:20]	Device	RW	2	Default device: 0h = Line out; 1h = Speaker; 2h = HP out; 3h = CD; 4h = SPDIF Out; 5h = Digital other out; 6h = Modem line side; 7h = Modem handset side; 8h = Line in; 9h = Aux; Ah = Mic in; Bh = Telephony; Ch = SPDIF In; Dh = Digital other in; Eh = Reserved; Fh = Other

8.3.11.1. *PortA ConfigDefault*

Bit	Bitfield Name	RW	Reset	Description
[19.:16]	Connection Type	RW	1	Connection type: 0h = Unknown; 1h = 1/8" stereo/mono; 2h = 1/4" stereo/mono; 3h = ATAPI internal; 4h = RCA; 5h = Optical; 6h = Other digital; 7h = Other analog; 8h = Multichannel analog (DIN); 9h = XLR/Professional; Ah = RJ-11 (modem); Bh = Combination; Ch-Eh = Reserved; Fh = Other
[15.:12]	Color	RW	4	Color: 0h = Unknown; 1h = Black; 2h = Grey; 3h = Blue; 4h = Green; 5h = Red; 6h = Orange; 7h = Yellow; 8h = Purple; 9h = Pink; Ah-Dh = Reserved; Eh = White; Fh = Other
[11.:8]	Misc	RW	0	Miscellaneous: Bits [3..1] = Reserved; Bit 0 = Jack detect override
[7.:4]	Association	RW	3	Default association.
[3.:0]	Sequence	RW	0	Sequence.

8.4. **PortB Node (NID = 0B)**8.4.1. *PortB WCap*

	Verb ID	Payload	Response
Get	F00	09	See bitfield table.

8.4.1.1. *PortB WCap*

Bit	Bitfield Name	RW	Reset	Description
[31.:24]	Rsvd2	R	00	Reserved.
[23.:20]	Type	R	4	Widget type: 0h = Out Converter; 1h = In Converter; 2h = Summing (Mixer); 3h = Selector (Mux); 4h = Pin Complex; 5h = Power; 6h = Volume Knob; 7h = Beep Generator; 8h-Eh = Reserved; Fh = Vendor Defined

8.4.1.1. *PortB WCap*

Bit	Bitfield Name	RW	Reset	Description
[19.:16]	Delay	R	0	Number of sample delays through widget.
[15.:12]	Rsvd1	R	0	Reserved.
[11]	SwapCap	R	0	Left/right swap support: 1 = yes 0 = no.
[10]	PwrCntrl	R	0	Power state support: 1 = yes 0 = no.
[9]	Dig	R	0	Digital stream support: 1 = yes (digital) 0 = no (analog).
[8]	ConnList	R	0	Connection list present: 1 = yes 0 = no.
[7]	UnSolCap	R	1	Unsolicited response support: 1 = yes 0 = no.
[6]	ProcWidget	R	0	Processing state support: 1 = yes 0 = no.
[5]	Stripe	R	0	Striping support: 1 = yes 0 = no.
[4]	FormatOvrd	R	0	Stream format override: 1 = yes 0 = no.
[3]	AmpParOvrd	R	0	Amplifier capabilities override: 1 = yes no.
[2]	OutAmpPrsnt	R	0	Output amp present: 1 = yes 0 = no.
[1]	InAmpPrsnt	R	0	Input amp present: 1 = yes 0 = no.
[0]	Stereo	R	1	Stereo stream support: 1 = yes (stereo) 0 = no (mono).

8.4.2. *PortB PinCap*

	Verb ID	Payload	Response
Get	F00	0C	See bitfield table.

8.4.2.1. *PortB PinCap*

Bit	Bitfield Name	RW	Reset	Description
[31.:17]	Rsvd2	R	0000	Reserved.
[16]	EapdCap	R	0	EAPD support: 1 = yes 0 = no.
[15.:8]	VrefCntrl	R	17	Vref support: bit 7 = Reserved; bit 6 = Reserved; bit 5 = 100% support (1 = yes 0 = no); bit 4 = 80% support (1 = yes 0 = no); bit 3 = Reserved; bit 2 = GND support (1 = yes 0 = no); bit 1 = 50% support (1 = yes 0 = no); bit 0 = Hi-Z support (1 = yes 0 = no)
[7]	Rsvd1	R	0	Reserved.
[6]	BalancedIO	R	0	Balanced I/O support: 1 = yes 0 = no.
[5]	InCap	R	1	Input support: 1 = yes 0 = no.
[4]	OutCap	R	0	Output support: 1 = yes 0 = no.
[3]	HdphDrvCap	R	0	Headphone amp present: 1 = yes 0 = no.
[2]	PresDtctCap	R	1	Presence detection support: 1 = yes 0 = no.
[1]	TrigRqd	R	0	Trigger required for impedance sense: 1 = yes 0 = no.
[0]	ImpSenseCap	R	0	Impedance sense support: 1 = yes 0 = no.

8.4.3. *PortB PinWCntrl*

	Verb ID	Payload	Response
Get	F07	00	See bitfield table.

8.4.3.1. *PortB PinWCntrl*

Bit	Bitfield Name	RW	Reset	Description
[31.:6]	Rsvd2	R	0000000	Reserved.
[5]	InEn	RW	0	Input enable: 1 = enabled 0 = disabled.
[4.:3]	Rsvd1	R	0	Reserved.
[2.:0]	VRefEn	RW	0	Vref selection (See VrefCntrl field of PinCap parameter for supported selections): 000b= HI-Z; 001b= 50%; 010b= GND; 011b= Reserved; 100b= 80%; 101b= 100%; 110b= Reserved; 111b= Reserved

8.4.4. *PortB UnsolicitedResp*

	Verb ID	Payload	Response
Get	F08	00	See bitfield table.

8.4.4.1. *PortB UnsolicitedResp*

Bit	Bitfield Name	RW	Reset	Description
[31.:8]	Rsvd2	R	000000	Reserved.
[7]	En	RW	0	Unsolicited response enable: 1 = enabled 0 = disabled.
[6]	Rsvd1	R	0	Reserved.
[5.:0]	Tag	RW	00	Software programmable field returned in top six bits (31:26) of every Unsolicited Response generated by this node.

8.4.5. PortB ChSense

	Verb ID	Payload	Response
Get	F09	00	See bitfield table.

8.4.5.1. PortB ChSense

Bit	Bitfield Name	RW	Reset	Description
[31]	PresDtct	R	0	Presence detection indicator: 1 = presence detected; 0 = presence not detected.
[30.:0]	Rsvd	R	0	Reserved.

8.4.6. PortB ConfigDefault

	Verb ID	Payload	Response
Get	F1C	00	See bitfield table.

8.4.6.1. PortB ConfigDefault

Bit	Bitfield Name	RW	Reset	Description
[31.:30]	PortConnectivity	RW	0	Port connectivity: 0h = Port complex is connected to a jack; 1h = No physical connection for port; 2h = Fixed function device is attached; 3h = Both jack and internal device attached (info in all other fields refers to integrated device any presence detection refers to jack)
[29.:24]	Location	RW	02	Location. Bits [5..4]: 0h = External on primary chassis; 1h = Internal; 2h = Separate chassis; 3h = Other. Bits [3..0]: 0h = N/A; 1h = Rear; 2h = Front; 3h = Left; 4h = Right; 5h = Top; 6h = Bottom; 7h-9h = Special; Ah-Fh = Reserved

8.4.6.1. *PortB ConfigDefault*

Bit	Bitfield Name	RW	Reset	Description
[23.:20]	Device	RW	A	Default device: 0h = Line out; 1h = Speaker; 2h = HP out; 3h = CD; 4h = SPDIF Out; 5h = Digital other out; 6h = Modem line side; 7h = Modem handset side; 8h = Line in; 9h = Aux; Ah = Mic in; Bh = Telephony; Ch = SPDIF In; Dh = Digital other in; Eh = Reserved; Fh = Other
[19.:16]	ConnectionType	RW	1	Connection type: 0h = Unknown; 1h = 1/8" stereo/mono; 2h = 1/4" stereo/mono; 3h = ATAPI internal; 4h = RCA; 5h = Optical; 6h = Other digital; 7h = Other analog; 8h = Multichannel analog (DIN); 9h = XLR/Professional; Ah = RJ-11 (modem); Bh = Combination; Ch-Eh = Reserved; Fh = Other
[15.:12]	Color	RW	9	Color: 0h = Unknown; 1h = Black; 2h = Grey; 3h = Blue; 4h = Green; 5h = Red; 6h = Orange; 7h = Yellow; 8h = Purple; 9h = Pink; Ah-Dh = Reserved; Eh = White; Fh = Other
[11.:8]	Misc	RW	0	Miscellaneous: Bits [3..1] = Reserved; Bit 0 = Jack detect override
[7.:4]	Association	RW	4	Default association.
[3.:0]	Sequence	RW	0	Sequence.

8.5. **Port C Node (NID = 0C)**8.5.1. *PortC WCap*

	Verb ID	Payload	Response
Get	F00	09	See bitfield table.

8.5.1.1. *PortC WCap*

Bit	Bitfield Name	RW	Reset	Description
[31.:24]	Rsvd2	R	00	Reserved.
[23.:20]	Type	R	4	Widget type: 0h = Out Converter; 1h = In Converter; 2h = Summing (Mixer); 3h = Selector (Mux); 4h = Pin Complex; 5h = Power; 6h = Volume Knob; 7h = Beep Generator; 8h-Eh = Reserved; Fh = Vendor Defined
[19.:16]	Delay	R	0	Number of sample delays through widget.
[15.:12]	Rsvd1	R	0	Reserved.
[11]	SwapCap	R	0	Left/right swap support: 1 = yes 0 = no.
[10]	PwrCntrl	R	0	Power state support: 1 = yes 0 = no.
[9]	Dig	R	0	Digital stream support: 1 = yes (digital) 0 = no (analog).
[8]	ConnList	R	0	Connection list present: 1 = yes 0 = no.
[7]	UnSolCap	R	1	Unsolicited response support: 1 = yes 0 = no.
[6]	ProcWidget	R	0	Processing state support: 1 = yes 0 = no.
[5]	Stripe	R	0	Striping support: 1 = yes 0 = no.
[4]	FormatOvrd	R	0	Stream format override: 1 = yes 0 = no.
[3]	AmpParOvrd	R	0	Amplifier capabilities override: 1 = yes no.
[2]	OutAmpPrsnt	R	0	Output amp present: 1 = yes 0 = no.
[1]	InAmpPrsnt	R	0	Input amp present: 1 = yes 0 = no.
[0]	Stereo	R	1	Stereo stream support: 1 = yes (stereo) 0 = no (mono).

8.5.2. PortC PinCap

	Verb ID	Payload	Response
Get	F00	0C	See bitfield table.

8.5.2.1. PortC PinCap

Bit	Bitfield Name	RW	Reset	Description
[31.:17]	Rsvd2	R	0000	Reserved.
[16]	EapdCap	R	0	EAPD support: 1 = yes 0 = no.
[15.:8]	VrefCntrl	R	17	Vref support: bit 7 = Reserved; bit 6 = Reserved; bit 5 = 100% support (1 = yes 0 = no); bit 4 = 80% support (1 = yes 0 = no); bit 3 = Reserved; bit 2 = GND support (1 = yes 0 = no); bit 1 = 50% support (1 = yes 0 = no); bit 0 = Hi-Z support (1 = yes 0 = no)
[7]	Rsvd1	R	0	Reserved.
[6]	BalancedIO	R	0	Balanced I/O support: 1 = yes 0 = no.
[5]	InCap	R	1	Input support: 1 = yes 0 = no.
[4]	OutCap	R	0	Output support: 1 = yes 0 = no.
[3]	HdphDrvCap	R	0	Headphone amp present: 1 = yes 0 = no.
[2]	PresDtctCap	R	1	Presence detection support: 1 = yes 0 = no.
[1]	TrigRqd	R	0	Trigger required for impedance sense: 1 = yes 0 = no.
[0]	ImpSenseCap	R	0	Impedance sense support: 1 = yes 0 = no.

8.5.3. PortC PinWCntrl

	Verb ID	Payload	Response
Get	F07	00	See bitfield table.

8.5.3.1. PortC PinWCntrl

Bit	Bitfield Name	RW	Reset	Description
[31..6]	Rsvd2	R	0000000	Reserved.
[5]	InEn	RW	0	Input enable: 1 = enabled 0 = disabled.
[4..3]	Rsvd1	R	0	Reserved.
[2..0]	VRefEn	RW	0	Vref selection (See VrefCntrl field of PinCap parameter for supported selections): 000b= HI-Z; 001b= 50%; 010b= GND; 011b= Reserved; 100b= 80%; 101b= 100%; 110b= Reserved; 111b= Reserved

8.5.4. PortC UnsolResp

	Verb ID	Payload	Response
Get	F08	00	See bitfield table.

8.5.4.1. PortC UnsolResp

Bit	Bitfield Name	RW	Reset	Description
[31..8]	Rsvd2	R	000000	Reserved.
[7]	En	RW	0	Unsolicited response enable: 1 = enabled 0 = disabled.

8.5.4.1. *PortC UnsolicitedResponse*

Bit	Bitfield Name	RW	Reset	Description
[6]	Rsvd1	R	0	Reserved.
[5.:0]	Tag	RW	00	Software programmable field returned in top six bits (31:26) of every Unsolicited Response generated by this node.

8.5.5. *PortC ChSense*

	Verb ID	Payload	Response
Get	F09	00	See bitfield table.

8.5.5.1. *PortC ChSense*

Bit	Bitfield Name	RW	Reset	Description
[31]	PresDtct	R	0	Presence detection indicator: 1 = presence detected; 0 = presence not detected.
[30.:0]	Rsvd	R	0	Reserved.

8.5.6. *PortC ConfigDefault*

	Verb ID	Payload	Response
Get	F1C	00	See bitfield table.

8.5.6.1. *PortC ConfigDefault*

Bit	Bitfield Name	RW	Reset	Description
[31..30]	PortConnectivity	RW	0	Port connectivity: 0h = Port complex is connected to a jack; 1h = No physical connection for port; 2h = Fixed function device is attached; 3h = Both jack and internal device attached (info in all other fields refers to integrated device any presence detection refers to jack)
[29..24]	Location	RW	1	Location. Bits [5..4]: 0h = External on primary chassis; 1h = Internal; 2h = Separate chassis; 3h = Other. Bits [3..0]: 0h = N/A; 1h = Rear; 2h = Front; 3h = Left; 4h = Right; 5h = Top; 6h = Bottom; 7h-9h = Special; Ah-Fh = Reserved
[23..20]	Device	RW	A	Default device: 0h = Line out; 1h = Speaker; 2h = HP out; 3h = CD; 4h = SPDIF Out; 5h = Digital other out; 6h = Modem line side; 7h = Modem handset side; 8h = Line in; 9h = Aux; Ah = Mic in; Bh = Telephony; Ch = SPDIF In; Dh = Digital other in; Eh = Reserved; Fh = Other
[19..16]	ConnectionType	RW	1	Connection type: 0h = Unknown; 1h = 1/8" stereo/mono; 2h = 1/4" stereo/mono; 3h = ATAPI internal; 4h = RCA; 5h = Optical; 6h = Other digital; 7h = Other analog; 8h = Multichannel analog (DIN); 9h = XLR/Professional; Ah = RJ-11 (modem); Bh = Combination; Ch-Eh = Reserved; Fh = Other
[15..12]	Color	RW	9	Color: 0h = Unknown; 1h = Black; 2h = Grey; 3h = Blue; 4h = Green; 5h = Red; 6h = Orange; 7h = Yellow; 8h = Purple; 9h = Pink; Ah-Dh = Reserved; Eh = White; Fh = Other
[11..8]	Misc	RW	0	Miscellaneous: Bits [3..1] = Reserved; Bit 0 = Jack detect override
[7..4]	Association	RW	2	Default association.
[3..0]	Sequence	RW	0	Sequence.

8.6. Port D Node (NID = 0D)

8.6.1. PortD WCap

	Verb ID	Payload	Response
Get	F00	09	See bitfield table.

8.6.1.1. PortD WCap

Bit	Bitfield Name	RW	Reset	Description
[31..24]	Rsvd2	R	00	Reserved.
[23..20]	Type	R	4	Widget type: 0h = Out Converter; 1h = In Converter; 2h = Summing (Mixer); 3h = Selector (Mux); 4h = Pin Complex; 5h = Power; 6h = Volume Knob; 7h = Beep Generator; 8h-Eh = Reserved; Fh = Vendor Defined
[19..16]	Delay	R	0	Number of sample delays through widget.
[15..12]	Rsvd1	R	0	Reserved.
[11]	SwapCap	R	0	Left/right swap support: 1 = yes 0 = no.
[10]	PwrCntrl	R	0	Power state support: 1 = yes 0 = no.
[9]	Dig	R	0	Digital stream support: 1 = yes (digital) 0 = no (analog).
[8]	ConnList	R	1	Connection list present: 1 = yes 0 = no.
[7]	UnSolCap	R	1	Unsolicited response support: 1 = yes 0 = no.
[6]	ProcWidget	R	0	Processing state support: 1 = yes 0 = no.
[5]	Stripe	R	0	Striping support: 1 = yes 0 = no.
[4]	FormatOvrd	R	0	Stream format override: 1 = yes 0 = no.
[3]	AmpParOvrd	R	0	Amplifier capabilities override: 1 = yes no.
[2]	OutAmpPrsnt	R	0	Output amp present: 1 = yes 0 = no.

8.6.1.1. *PortD WCap*

Bit	Bitfield Name	RW	Reset	Description
[1]	InAmpPrsnt	R	0	Input amp present: 1 = yes 0 = no.
[0]	Stereo	R	1	Stereo stream support: 1 = yes (stereo) 0 = no (mono).

8.6.2. *PortD PinCap*

	Verb ID	Payload	Response
Get	F00	0C	See bitfield table.

8.6.2.1. *PortD PinCap*

Bit	Bitfield Name	RW	Reset	Description
[31.:17]	Rsvd2	R	0000	Reserved.
[16]	EapdCap	R	0	EAPD support: 1 = yes 0 = no.
[15.:8]	VrefCntrl	R	00	Vref support: bit 7 = Reserved; bit 6 = Reserved; bit 5 = 100% support (1 = yes 0 = no); bit 4 = 80% support (1 = yes 0 = no); bit 3 = Reserved; bit 2 = GND support (1 = yes 0 = no); bit 1 = 50% support (1 = yes 0 = no); bit 0 = Hi-Z support (1 = yes 0 = no)
[7]	Rsvd1	R	0	Reserved.
[6]	BalancedIO	R	0	Balanced I/O support: 1 = yes 0 = no.
[5]	InCap	R	0	Input support: 1 = yes 0 = no.
[4]	OutCap	R	1	Output support: 1 = yes 0 = no.
[3]	HdphDrvCap	R	0	Headphone amp present: 1 = yes 0 = no.
[2]	PresDtctCap	R	1	Presence detection support: 1 = yes 0 = no.

8.6.2.1. *PortD PinCap*

Bit	Bitfield Name	RW	Reset	Description
[1]	TrigRqd	R	0	Trigger required for impedance sense: 1 = yes 0 = no.
[0]	ImpSenseCap	R	0	Impedance sense support: 1 = yes 0 = no.

8.6.3. *PortD ConLst*

	Verb ID	Payload	Response
Get	F00	0E	See bitfield table.

8.6.3.1. *PortD ConLst*

Bit	Bitfield Name	RW	Reset	Description
[31..8]	Rsvd	R	000000	Reserved.
[7]	LForm	R	0	Connection list format: 1 = long-form (15-bit) NID entries 0 = short-form (7-bit) NID entries.
[6..0]	ConL	R	03	Number of NID entries in connection list.

8.6.4. *PortD ConLstEntry0*

	Verb ID	Payload	Response
Get	F02	00	See bitfield table.

8.6.4.1. *PortD ConLstEntry0*

Bit	Bitfield Name	RW	Reset	Description
[31.:24]	ConL3	R	00	Unused list entry.
[23.:16]	ConL2	R	17	InputMixer Summing widget (0x17)
[15.:8]	ConL1	R	11	DAC1 Converter widget (0x11)
[7.:0]	ConL0	R	10	DAC0 Converter widget (0x10)

8.6.5. *PortD ConSelectCtrl*

	Verb ID	Payload	Response
Get	F01	00	See bitfield table.

8.6.5.1. *PortD ConSelectCtrl*

Bit	Bitfield Name	RW	Reset	Description
[31.:2]	Rsvd	R	00000000	Reserved.
[1.:0]	Index	RW	0	Connection select control index.

8.6.6. *PortD PinWCntrl*

	Verb ID	Payload	Response
Get	F07	00	See bitfield table.

8.6.6.1. *PortD PinWCntrl*

Bit	Bitfield Name	RW	Reset	Description
[31.:7]	Rsvd2	R	000000	Reserved.
[6]	OutEn	RW	0	Output enable: 1 = enabled 0 = disabled.
[5.:0]	Rsvd1	R	0	Reserved.

8.6.7. *PortD UnsolicitedResp*

	Verb ID	Payload	Response
Get	F08	00	See bitfield table.

8.6.7.1. *PortD UnsolicitedResp*

Bit	Bitfield Name	RW	Reset	Description
[31.:8]	Rsvd2	R	000000	Reserved.
[7]	En	RW	0	Unsolicited response enable: 1 = enabled 0 = disabled.
[6]	Rsvd1	R	0	Reserved.
[5.:0]	Tag	RW	00	Software programmable field returned in top six bits (31:26) of every Unsolicited Response generated by this node.

8.6.8. *PortD ChSense*

	Verb ID	Payload	Response
Get	F09	00	See bitfield table.

8.6.8.1. PortD ChSense

Bit	Bitfield Name	RW	Reset	Description
[31]	PresDtct	R	0	Presence detection indicator: 1 = presence detected; 0 = presence not detected.
[30..:0]	Rsvd	R	0	Reserved.

8.6.9. PortD InAmpLeft

	Verb ID	Payload	Response
Get	B20	00	See bitfield table.

8.6.9.1. PortD InAmpLeft

Bit	Bitfield Name	RW	Reset	Description
[31..:8]	Rsvd2	R	000000	Reserved.
[7]	Mute	RW	1	Amp mute: 1 = muted 0 = not muted.
[6..:0]	Rsvd1	R	00	Reserved.

8.6.10. PortD InAmpRight

	Verb ID	Payload	Response
Get	B00	00	See bitfield table.

8.6.10.1. *PortD InAmpRight*

Bit	Bitfield Name	RW	Reset	Description
[31..8]	Rsvd2	R	000000	Reserved.
[7]	Mute	RW	1	Amp mute: 1 = muted 0 = not muted.
[6..0]	Rsvd1	R	00	Reserved.

8.6.11. *PortD ConfigDefault*

	Verb ID	Payload	Response
Get	F1C	00	See bitfield table.

8.6.11.1. *PortD ConfigDefault*

Bit	Bitfield Name	RW	Reset	Description
[31..30]	PortConnectivity	RW	0	Port connectivity: 0h = Port complex is connected to a jack; 1h = No physical connection for port; 2h = Fixed function device is attached; 3h = Both jack and internal device attached (info in all other fields refers to integrated device any presence detection refers to jack)
[29..24]	Location	RW	1	Location. Bits [5..4]: 0h = External on primary chassis; 1h = Internal; 2h = Separate chassis; 3h = Other. Bits [3..0]: 0h = N/A; 1h = Rear; 2h = Front; 3h = Left; 4h = Right; 5h = Top; 6h = Bottom; 7h-9h = Special; Ah-Fh = Reserved
[23..20]	Device	RW	0	Default device: 0h = Line out; 1h = Speaker; 2h = HP out; 3h = CD; 4h = SPDIF Out; 5h = Digital other out; 6h = Modem line side; 7h = Modem handset side; 8h = Line in; 9h = Aux; Ah = Mic in; Bh = Telephony; Ch = SPDIF In; Dh = Digital other in; Eh = Reserved; Fh = Other

8.6.11.1. *PortD ConfigDefault*

Bit	Bitfield Name	RW	Reset	Description
[19.:16]	ConnectionType	RW	1	Connection type: 0h = Unknown; 1h = 1/8" stereo/mono; 2h = 1/4" stereo/mono; 3h = ATAPI internal; 4h = RCA; 5h = Optical; 6h = Other digital; 7h = Other analog; 8h = Multichannel analog (DIN); 9h = XLR/Professional; Ah = RJ-11 (modem); Bh = Combination; Ch-Eh = Reserved; Fh = Other
[15.:12]	Color	RW	4	Color: 0h = Unknown; 1h = Black; 2h = Grey; 3h = Blue; 4h = Green; 5h = Red; 6h = Orange; 7h = Yellow; 8h = Purple; 9h = Pink; Ah-Dh = Reserved; Eh = White; Fh = Other
[11.:8]	Misc	RW	0	Miscellaneous: Bits [3..1] = Reserved; Bit 0 = Jack detect override
[7.:4]	Association	RW	1	Default association.
[3.:0]	Sequence	RW	0	Sequence.

8.7. **PortE Node (NID = 0E)**8.7.1. *PortE WCap*

	Verb ID	Payload	Response
Get	F00	09	See bitfield table.

8.7.1.1. *PortE WCap*

Bit	Bitfield Name	RW	Reset	Description
[31.:24]	Rsvd2	R	00	Reserved.
[23.:20]	Type	R	4	Widget type: 0h = Out Converter; 1h = In Converter; 2h = Summing (Mixer); 3h = Selector (Mux); 4h = Pin Complex; 5h = Power; 6h = Volume Knob; 7h = Beep Generator; 8h-Eh = Reserved; Fh = Vendor Defined

8.7.1.1. *PortE WCap*

Bit	Bitfield Name	RW	Reset	Description
[19.:16]	Delay	R	0	Number of sample delays through widget.
[15.:12]	Rsvd1	R	0	Reserved.
[11]	SwapCap	R	0	Left/right swap support: 1 = yes 0 = no.
[10]	PwrCntrl	R	0	Power state support: 1 = yes 0 = no.
[9]	Dig	R	0	Digital stream support: 1 = yes (digital) 0 = no (analog).
[8]	ConnList	R	0	Connection list present: 1 = yes 0 = no.
[7]	UnSolCap	R	1	Unsolicited response support: 1 = yes 0 = no.
[6]	ProcWidget	R	0	Processing state support: 1 = yes 0 = no.
[5]	Stripe	R	0	Striping support: 1 = yes 0 = no.
[4]	FormatOvrd	R	0	Stream format override: 1 = yes 0 = no.
[3]	AmpParOvrd	R	0	Amplifier capabilities override: 1 = yes no.
[2]	OutAmpPrsnt	R	0	Output amp present: 1 = yes 0 = no.
[1]	InAmpPrsnt	R	0	Input amp present: 1 = yes 0 = no.
[0]	Stereo	R	1	Stereo stream support: 1 = yes (stereo) 0 = no (mono).

8.7.2. *PortE PinCap*

	Verb ID	Payload	Response
Get	F00	0C	See bitfield table.

8.7.2.1. *PortE PinCap*

Bit	Bitfield Name	RW	Reset	Description
[31..17]	Rsvd2	R	0000	Reserved.
[16]	EapdCap	R	0	EAPD support: 1 = yes 0 = no.
[15..8]	VrefCntrl	R	17	Vref support: bit 7 = Reserved; bit 6 = Reserved; bit 5 = 100% support (1 = yes 0 = no); bit 4 = 80% support (1 = yes 0 = no); bit 3 = Reserved; bit 2 = GND support (1 = yes 0 = no); bit 1 = 50% support (1 = yes 0 = no); bit 0 = Hi-Z support (1 = yes 0 = no)
[7]	Rsvd1	R	0	Reserved.
[6]	BalancedIO	R	0	Balanced I/O support: 1 = yes 0 = no.
[5]	InCap	R	1	Input support: 1 = yes 0 = no.
[4]	OutCap	R	0	Output support: 1 = yes 0 = no.
[3]	HdphDrvCap	R	0	Headphone amp present: 1 = yes 0 = no.
[2]	PresDtctCap	R	1	Presence detection support: 1 = yes 0 = no.
[1]	TrigRqd	R	0	Trigger required for impedance sense: 1 = yes 0 = no.
[0]	ImpSenseCap	R	0	Impedance sense support: 1 = yes 0 = no.

8.7.3. *PortE PinWCntrl*

	Verb ID	Payload	Response
Get	F07	00	See bitfield table.

8.7.3.1. *PortE PinWCntrl*

Bit	Bitfield Name	RW	Reset	Description
[31.:6]	Rsvd2	R	0000000	Reserved.
[5]	InEn	RW	0	Input enable: 1 = enabled 0 = disabled.
[4.:3]	Rsvd1	R	0	Reserved.
[2.:0]	VRefEn	RW	0	Vref selection (See VrefCntrl field of PinCap parameter for supported selections): 000b= HI-Z; 001b= 50%; 010b= GND; 011b= Reserved; 100b= 80%; 101b= 100%; 110b= Reserved; 111b= Reserved

8.7.4. *PortE UnsolicitedResp*

	Verb ID	Payload	Response
Get	F08	00	See bitfield table.

8.7.4.1. *PortE UnsolicitedResp*

Bit	Bitfield Name	RW	Reset	Description
[31.:8]	Rsvd2	R	000000	Reserved.
[7]	En	RW	0	Unsolicited response enable: 1 = enabled 0 = disabled.
[6]	Rsvd1	R	0	Reserved.
[5.:0]	Tag	RW	00	Software programmable field returned in top six bits (31:26) of every Unsolicited Response generated by this node.

8.7.5. PortE ChSense

	Verb ID	Payload	Response
Get	F09	00	See bitfield table.

8.7.5.1. PortE ChSense

Bit	Bitfield Name	RW	Reset	Description
[31]	PresDtct	R	0	Presence detection indicator: 1 = presence detected; 0 = presence not detected.
[30.:0]	Rsvd	R	0	Reserved.

8.7.6. PortE ConfigDefault

	Verb ID	Payload	Response
Get	F1C	00	See bitfield table.

8.7.6.1. PortE ConfigDefault

Bit	Bitfield Name	RW	Reset	Description
[31.:30]	PortConnectivity	RW	0	Port connectivity: 0h = Port complex is connected to a jack; 1h = No physical connection for port; 2h = Fixed function device is attached; 3h = Both jack and internal device attached (info in all other fields refers to integrated device any presence detection refers to jack)
[29.:24]	Location	RW	1	Location. Bits [5..4]: 0h = External on primary chassis; 1h = Internal; 2h = Separate chassis; 3h = Other. Bits [3..0]: 0h = N/A; 1h = Rear; 2h = Front; 3h = Left; 4h = Right; 5h = Top; 6h = Bottom; 7h-9h = Special; Ah-Fh = Reserved

8.7.6.1. *PortE ConfigDefault*

Bit	Bitfield Name	RW	Reset	Description
[23.:20]	Device	RW	8	Default device: 0h = Line out; 1h = Speaker; 2h = HP out; 3h = CD; 4h = SPDIF Out; 5h = Digital other out; 6h = Modem line side; 7h = Modem handset side; 8h = Line in; 9h = Aux; Ah = Mic in; Bh = Telephony; Ch = SPDIF In; Dh = Digital other in; Eh = Reserved; Fh = Other
[19.:16]	ConnectionType	RW	1	Connection type: 0h = Unknown; 1h = 1/8" stereo/mono; 2h = 1/4" stereo/mono; 3h = ATAPI internal; 4h = RCA; 5h = Optical; 6h = Other digital; 7h = Other analog; 8h = Multichannel analog (DIN); 9h = XLR/Professional; Ah = RJ-11 (modem); Bh = Combination; Ch-Eh = Reserved; Fh = Other
[15.:12]	Color	RW	3	Color: 0h = Unknown; 1h = Black; 2h = Grey; 3h = Blue; 4h = Green; 5h = Red; 6h = Orange; 7h = Yellow; 8h = Purple; 9h = Pink; Ah-Dh = Reserved; Eh = White; Fh = Other
[11.:8]	Misc	RW	0	Miscellaneous: Bits [3..1] = Reserved; Bit 0 = Jack detect override
[7.:4]	Association	RW	2	Default association.
[3.:0]	Sequence	RW	E	Sequence.

8.8. **PortF Node (NID = 0F) 48QFN package only**8.8.1. *PortF WCap*

	Verb ID	Payload	Response
Get	F00	09	See bitfield table.

8.8.1.1. *PortF WCap*

Bit	Bitfield Name	RW	Reset	Description
[31.:24]	Rsvd2	R	00	Reserved.
[23.:20]	Type	R	4	Widget type: 0h = Out Converter; 1h = In Converter; 2h = Summing (Mixer); 3h = Selector (Mux); 4h = Pin Complex; 5h = Power; 6h = Volume Knob; 7h = Beep Generator; 8h-Eh = Reserved; Fh = Vendor Defined
[19.:16]	Delay	R	0	Number of sample delays through widget.
[15.:12]	Rsvd1	R	0	Reserved.
[11]	SwapCap	R	0	Left/right swap support: 1 = yes 0 = no.
[10]	PwrCntrl	R	0	Power state support: 1 = yes 0 = no.
[9]	Dig	R	0	Digital stream support: 1 = yes (digital) 0 = no (analog).
[8]	ConnList	R	1	Connection list present: 1 = yes 0 = no.
[7]	UnSolCap	R	1	Unsolicited response support: 1 = yes 0 = no.
[6]	ProcWidget	R	0	Processing state support: 1 = yes 0 = no.
[5]	Stripe	R	0	Striping support: 1 = yes 0 = no.
[4]	FormatOvrd	R	0	Stream format override: 1 = yes 0 = no.
[3]	AmpParOvrd	R	0	Amplifier capabilities override: 1 = yes no.
[2]	OutAmpPrsnt	R	0	Output amp present: 1 = yes 0 = no.
[1]	InAmpPrsnt	R	0	Input amp present: 1 = yes 0 = no.
[0]	Stereo	R	1	Stereo stream support: 1 = yes (stereo) 0 = no (mono).

8.8.2. PortF PinCap

	Verb ID	Payload	Response
Get	F00	0C	See bitfield table.

8.8.2.1. PortF PinCap

Bit	Bitfield Name	RW	Reset	Description
[31.:17]	Rsvd2	R	0000	Reserved.
[16]	EapdCap	R	0	EAPD support: 1 = yes 0 = no.
[15.:8]	VrefCntrl	R	00	Vref support: bit 7 = Reserved; bit 6 = Reserved; bit 5 = 100% support (1 = yes 0 = no); bit 4 = 80% support (1 = yes 0 = no); bit 3 = Reserved; bit 2 = GND support (1 = yes 0 = no); bit 1 = 50% support (1 = yes 0 = no); bit 0 = Hi-Z support (1 = yes 0 = no)
[7]	Rsvd1	R	0	Reserved.
[6]	BalancedIO	R	0	Balanced I/O support: 1 = yes 0 = no.
[5]	InCap	R	0	Input support: 1 = yes 0 = no.
[4]	OutCap	R	1	Output support: 1 = yes 0 = no.
[3]	HdphDrvCap	R	0	Headphone amp present: 1 = yes 0 = no.
[2]	PresDtctCap	R	1	Presence detection support: 1 = yes 0 = no.
[1]	TrigRqd	R	0	Trigger required for impedance sense: 1 = yes 0 = no.
[0]	ImpSenseCap	R	0	Impedance sense support: 1 = yes 0 = no.

8.8.3. PortF ConLst

	Verb ID	Payload	Response
Get	F00	0E	See bitfield table.

8.8.3.1. PortF ConLst

Bit	Bitfield Name	RW	Reset	Description
[31..8]	Rsvd	R	000000	Reserved.
[7]	LForm	R	0	Connection list format: 1 = long-form (15-bit) NID entries 0 = short-form (7-bit) NID entries.
[6..0]	ConL	R	03	Number of NID entries in connection list.

8.8.4. PortF ConLstEntry0

	Verb ID	Payload	Response
Get	F02	00	See bitfield table.

8.8.4.1. PortF ConLstEntry0

Bit	Bitfield Name	RW	Reset	Description
[31..24]	ConL3	R	00	Unused list entry.
[23..16]	ConL2	R	17	InputMixer Summing widget (0x17)
[15..8]	ConL1	R	11	DAC1 Converter widget (0x11)
[7..0]	ConL0	R	10	DAC0 Converter widget (0x10)

8.8.5. PortF ConSelectCtrl

	Verb ID	Payload	Response
Get	F01	00	See bitfield table.

8.8.5.1. PortF ConSelectCtrl

Bit	Bitfield Name	RW	Reset	Description
[31..2]	Rsvd	R	00000000	Reserved.
[1..0]	Index	RW	0	Connection select control index.

8.8.6. PortF PinWCntrl

	Verb ID	Payload	Response
Get	F07	00	See bitfield table.

8.8.6.1. PortF PinWCntrl

Bit	Bitfield Name	RW	Reset	Description
[31..7]	Rsvd2	R	000000	Reserved.
[6]	OutEn	RW	0	Output enable: 1 = enabled 0 = disabled.
[5..0]	Rsvd1	R	0	Reserved.

8.8.7. PortF UnsolResp

	Verb ID	Payload	Response
Get	F08	00	See bitfield table.

8.8.7.1. *PortF UnsolResp*

Bit	Bitfield Name	RW	Reset	Description
[31..8]	Rsvd2	R	000000	Reserved.
[7]	En	RW	0	Unsolicited response enable: 1 = enabled 0 = disabled.
[6]	Rsvd1	R	0	Reserved.
[5..0]	Tag	RW	00	Software programmable field returned in top six bits (31:26) of every Unsolicited Response generated by this node.

8.8.8. *PortF ChSense*

	Verb ID	Payload	Response
Get	F09	00	See bitfield table.

8.8.8.1. *PortF ChSense*

Bit	Bitfield Name	RW	Reset	Description
[31]	PresDtct	R	0	Presence detection indicator: 1 = presence detected; 0 = presence not detected.
[30..0]	Rsvd	R	0	Reserved.

8.8.9. *PortF InAmpLeft*

	Verb ID	Payload	Response
Get	B20	00	See bitfield table.

8.8.9.1. PortF InAmpLeft

Bit	Bitfield Name	RW	Reset	Description
[31..8]	Rsvd2	R	000000	Reserved.
[7]	Mute	RW	1	Amp mute: 1 = muted 0 = not muted.
[6.:0]	Rsvd1	R	00	Reserved.

8.8.10. PortF InAmpRight

	Verb ID	Payload	Response
Get	B00	00	See bitfield table.

8.8.10.1. PortF InAmpRight

Bit	Bitfield Name	RW	Reset	Description
[31..8]	Rsvd2	R	000000	Reserved.
[7]	Mute	RW	1	Amp mute: 1 = muted 0 = not muted.
[6.:0]	Rsvd1	R	00	Reserved.

8.8.11. PortF ConfigDefault

	Verb ID	Payload	Response
Get	F1C	00	See bitfield table.

8.8.11.1. *PortF ConfigDefault*

Bit	Bitfield Name	RW	Reset	Description
[31.:30]	PortConnectivity	RW	1	Port connectivity: 0h = Port complex is connected to a jack; 1h = No physical connection for port; 2h = Fixed function device is attached; 3h = Both jack and internal device attached (info in all other fields refers to integrated device any presence detection refers to jack)
[29.:24]	Location	RW	00	Location. Bits [5..4]: 0h = External on primary chassis; 1h = Internal; 2h = Separate chassis; 3h = Other. Bits [3..0]: 0h = N/A; 1h = Rear; 2h = Front; 3h = Left; 4h = Right; 5h = Top; 6h = Bottom; 7h-9h = Special; Ah-Fh = Reserved
[23.:20]	Device	RW	F	Default device: 0h = Line out; 1h = Speaker; 2h = HP out; 3h = CD; 4h = SPDIF Out; 5h = Digital other out; 6h = Modem line side; 7h = Modem handset side; 8h = Line in; 9h = Aux; Ah = Mic in; Bh = Telephony; Ch = SPDIF In; Dh = Digital other in; Eh = Reserved; Fh = Other
[19.:16]	ConnectionType	RW	0	Connection type: 0h = Unknown; 1h = 1/8" stereo/mono; 2h = 1/4" stereo/mono; 3h = ATAPI internal; 4h = RCA; 5h = Optical; 6h = Other digital; 7h = Other analog; 8h = Multichannel analog (DIN); 9h = XLR/Professional; Ah = RJ-11 (modem); Bh = Combination; Ch-Eh = Reserved; Fh = Other
[15.:12]	Color	RW	0	Color: 0h = Unknown; 1h = Black; 2h = Grey; 3h = Blue; 4h = Green; 5h = Red; 6h = Orange; 7h = Yellow; 8h = Purple; 9h = Pink; Ah-Dh = Reserved; Eh = White; Fh = Other
[11.:8]	Misc	RW	0	Miscellaneous: Bits [3..1] = Reserved; Bit 0 = Jack detect override
[7.:4]	Association	RW	F	Default association.
[3.:0]	Sequence	RW	0	Sequence.

8.9. DAC0 Node (NID = 10)

8.9.1. DAC0 WCap

	Verb ID	Payload	Response
Get	F00	09	See bitfield table.

8.9.1.1. DAC0 WCap

Bit	Bitfield Name	RW	Reset	Description
[31.:24]	Rsvd2	R	00	Reserved.
[23.:20]	Type	R	0	Widget type: 0h = Out Converter; 1h = In Converter; 2h = Summing (Mixer); 3h = Selector (Mux); 4h = Pin Complex; 5h = Power; 6h = Volume Knob; 7h = Beep Generator; 8h-Eh = Reserved; Fh = Vendor Defined
[19.:16]	Delay	R	D	Number of sample delays through widget.
[15.:12]	Rsvd1	R	0	Reserved.
[11]	SwapCap	R	1	Left/right swap support: 1 = yes 0 = no.
[10]	PwrCntrl	R	1	Power state support: 1 = yes 0 = no.
[9]	Dig	R	0	Digital stream support: 1 = yes (digital) 0 = no (analog).
[8]	ConnList	R	0	Connection list present: 1 = yes 0 = no.
[7]	UnSolCap	R	0	Unsolicited response support: 1 = yes 0 = no.
[6]	ProcWidget	R	0	Processing state support: 1 = yes 0 = no.
[5]	Stripe	R	0	Striping support: 1 = yes 0 = no.
[4]	FormatOvrd	R	0	Stream format override: 1 = yes 0 = no.
[3]	AmpParOvrd	R	0	Amplifier capabilities override: 1 = yes 0 = no.
[2]	OutAmpPrsnt	R	1	Output amp present: 1 = yes 0 = no.

8.9.1.1. *DAC0 WCap*

Bit	Bitfield Name	RW	Reset	Description
[1]	InAmpPrsnt	R	0	Input amp present: 1 = yes 0 = no.
[0]	Stereo	R	1	Stereo stream support: 1 = yes (stereo) 0 = no (mono).

8.9.2. *DAC0 Cnvtr*

	Verb ID	Payload	Response
Get	A	0000	See bitfield table.

8.9.2.1. *DAC0 Cnvtr*

Bit	Bitfield Name	RW	Reset	Description
[31.:16]	Rsvd2	R	0000	Reserved.
[15]	StrmType	R	0	Stream type: 1 = Non-PCM 0 = PCM.
[14]	FrmtSmplRate	RW	0	Sample base rate: 1 = 44.1kHz 0 = 48kHz.
[13.:11]	SmplRateMultp	RW	0	Sample base rate multiple: 000b= x1 (48kHz/44.1kHz or less); 001b= x2 (96kHz/88.2kHz/32kHz); 010b= x3 (144kHz); 011b= x4 (192kHz/176.4kHz); 100b-111b Reserved
[10.:8]	SmplRateDiv	RW	0	Sample base rate divider: 000b= Divide by 1 (48kHz/44.1kHz); 001b= Divide by 2 (24kHz/20.05kHz); 010b= Divide by 3 (16kHz/32kHz); 011b= Divide by 4 (11.025kHz); 100b= Divide by 5 (9.6kHz); 101b= Divide by 6 (8kHz); 110b= Divide by 7; 111b= Divide by 8 (6kHz)
[7]	Rsvd1	R	0	Reserved.

8.9.2.1. *DAC0 Cnvtr*

Bit	Bitfield Name	RW	Reset	Description
[6.:4]	BitsPerSmpl	RW	3	Bits per sample: 000b= 8 bits; 001b= 16 bits; 010b= 20 bits; 011b= 24 bits; 100b= 32 bits; 101b-111b= Reserved
[3.:0]	NmbrChan	RW	1	Total number of channels in the stream assigned to this converter: 0000b-1111b= 1-16 channels.

8.9.3. *DAC0 OutAmpLeft*

	Verb ID	Payload	Response
Get	BA0	00	See bitfield table.

8.9.3.1. *DAC0 OutAmpLeft*

Bit	Bitfield Name	RW	Reset	Description
[31.:8]	Rsvd	R	000000	Reserved.
[7]	Mute	RW	1	Amp mute: 1 = muted 0 = not muted.
[6.:0]	Gain	RW	7F	Amp gain step number (see OutAmp-Cap parameter pertaining to this widget).

8.9.4. *DAC0 OutAmpRight*

	Verb ID	Payload	Response
Get	B80	00	See bitfield table.

8.9.4.1. *DAC0 OutAmpRight*

Bit	Bitfield Name	RW	Reset	Description
[31..8]	Rsvd	R	000000	Reserved.
[7]	Mute	RW	1	Amp mute: 1 = muted 0 = not muted.
[6..0]	Gain	RW	7F	Amp gain step number (see OutAmp-Cap parameter pertaining to this widget).

8.9.5. *DAC0 PwrState*

	Verb ID	Payload	Response
Get	F05	00	See bitfield table.

8.9.5.1. *DAC0 PwrState*

Bit	Bitfield Name	RW	Reset	Description
[31..6]	Rsvd2	R	0000000	Reserved.
[5..4]	Act	R	3	Actual power state of this widget.
[3..2]	Rsvd1	R	0	Reserved.
[1..0]	Set	RW	3	Current power state setting for this widget.

8.9.6. *DAC0 CnvtrID*

	Verb ID	Payload	Response
Get	F06	00	See bitfield table.

8.9.6.1. *DAC0 CnvtrID*

Bit	Bitfield Name	RW	Reset	Description
[31..8]	Rsvd	R	000000	Reserved.
[7..4]	Strm	RW	0	Stream ID: 0h = Converter "off" 1h-Fh = valid IDs.
[3..0]	Ch	RW	0	Channel assignment ("Ch" and "Ch+1" assigned as a pair for a stereo converter).

8.9.7. *DAC0 LR*

	Verb ID	Payload	Response
Get	F0C	00	See bitfield table.

8.9.7.1. *DAC0 LR*

Bit	Bitfield Name	RW	Reset	Description
[31..3]	Rsvd2	R	00000000	Reserved.
[2]	SwapEn	RW	0	Swap enable: 1 = L/R swap enabled 0 = L/R swap disabled.
[1..0]	Rsvd1	R	0	Reserved.

8.10. *DAC1 Node (NID = 11)*8.10.1. *DAC1 WCap*

	Verb ID	Payload	Response
Get	F00	09	See bitfield table.

8.10.1.1. DAC1 WCap

Bit	Bitfield Name	RW	Reset	Description
[31.:24]	Rsvd2	R	00	Reserved.
[23.:20]	Type	R	0	Widget type: 0h = Out Converter; 1h = In Converter; 2h = Summing (Mixer); 3h = Selector (Mux); 4h = Pin Complex; 5h = Power; 6h = Volume Knob; 7h = Beep Generator; 8h-Eh = Reserved; Fh = Vendor Defined
[19.:16]	Delay	R	D	Number of sample delays through widget.
[15.:12]	Rsvd1	R	0	Reserved.
[11]	SwapCap	R	1	Left/right swap support: 1 = yes 0 = no.
[10]	PwrCntrl	R	1	Power state support: 1 = yes 0 = no.
[9]	Dig	R	0	Digital stream support: 1 = yes (digital) 0 = no (analog).
[8]	ConnList	R	0	Connection list present: 1 = yes 0 = no.
[7]	UnSolCap	R	0	Unsolicited response support: 1 = yes 0 = no.
[6]	ProcWidget	R	0	Processing state support: 1 = yes 0 = no.
[5]	Stripe	R	0	Striping support: 1 = yes 0 = no.
[4]	FormatOvrd	R	0	Stream format override: 1 = yes 0 = no.
[3]	AmpParOvrd	R	0	Amplifier capabilities override: 1 = yes no.
[2]	OutAmpPrsnt	R	1	Output amp present: 1 = yes 0 = no.
[1]	InAmpPrsnt	R	0	Input amp present: 1 = yes 0 = no.
[0]	Stereo	R	1	Stereo stream support: 1 = yes (stereo) 0 = no (mono).

8.10.2. DAC1 Cnvtr

	Verb ID	Payload	Response
Get	A	0000	See bitfield table.

8.10.2.1. DAC1 Cnvtr

Bit	Bitfield Name	RW	Reset	Description
[31.:16]	Rsvd2	R	0000	Reserved.
[15]	StrmType	R	0	Stream type: 1 = Non-PCM 0 = PCM.
[14]	FrmtSmplRate	RW	0	Sample base rate: 1 = 44.1kHz 0 = 48kHz.
[13.:11]	SmplRateMultp	RW	0	Sample base rate multiple: 000b= x1 (48kHz/44.1kHz or less); 001b= x2 (96kHz/88.2kHz/32kHz); 010b= x3 (144kHz); 011b= x4 (192kHz/176.4kHz); 100b-111b Reserved
[10.:8]	SmplRateDiv	RW	0	Sample base rate divider: 000b= Divide by 1 (48kHz/44.1kHz); 001b= Divide by 2 (24kHz/20.05kHz); 010b= Divide by 3 (16kHz/32kHz); 011b= Divide by 4 (11.025kHz); 100b= Divide by 5 (9.6kHz); 101b= Divide by 6 (8kHz); 110b= Divide by 7; 111b= Divide by 8 (6kHz)
[7]	Rsvd1	R	0	Reserved.
[6.:4]	BitsPerSmpl	RW	3	Bits per sample: 000b= 8 bits; 001b= 16 bits; 010b= 20 bits; 011b= 24 bits; 100b= 32 bits; 101b-111b= Reserved
[3.:0]	NmbrChan	RW	1	Total number of channels in the stream assigned to this converter: 0000b-1111b= 1-16 channels.

8.10.3. DAC1 OutAmpLeft

	Verb ID	Payload	Response
Get	BA0	00	See bitfield table.

8.10.3.1. DAC1 OutAmpLeft

Bit	Bitfield Name	RW	Reset	Description
[31..8]	Rsvd	R	000000	Reserved.
[7]	Mute	RW	1	Amp mute: 1 = muted 0 = not muted.
[6..0]	Gain	RW	7F	Amp gain step number (see OutAmp-Cap parameter pertaining to this widget).

8.10.4. DAC1 OutAmpRight

	Verb ID	Payload	Response
Get	B80	00	See bitfield table.

8.10.4.1. DAC1 OutAmpRight

Bit	Bitfield Name	RW	Reset	Description
[31..8]	Rsvd	R	000000	Reserved.
[7]	Mute	RW	1	Amp mute: 1 = muted 0 = not muted.
[6..0]	Gain	RW	7F	Amp gain step number (see OutAmp-Cap parameter pertaining to this widget).

8.10.5. DAC1 PwrState

	Verb ID	Payload	Response
Get	F05	00	See bitfield table.

8.10.5.1. DAC1 PwrState

Bit	Bitfield Name	RW	Reset	Description
[31..6]	Rsvd2	R	0000000	Reserved.
[5..4]	Act	R	3	Actual power state of this widget.
[3..2]	Rsvd1	R	0	Reserved.
[1..0]	Set	RW	3	Current power state setting for this widget.

8.10.6. DAC1 CnvtrID

	Verb ID	Payload	Response
Get	F06	00	See bitfield table.

8.10.6.1. DAC1 CnvtrID

Bit	Bitfield Name	RW	Reset	Description
[31..8]	Rsvd	R	000000	Reserved.
[7..4]	Strm	RW	0	Stream ID: 0h = Converter "off" 1h-Fh = valid IDs.
[3..0]	Ch	RW	0	Channel assignment ("Ch" and "Ch+1" assigned as a pair for a stereo converter).

8.10.7. DAC1 LR

	Verb ID	Payload	Response
Get	F0C	00	See bitfield table.

8.10.7.1. DAC1 LR

Bit	Bitfield Name	RW	Reset	Description
[31..3]	Rsvd2	R	00000000	Reserved.
[2]	SwapEn	RW	0	Swap enable: 1 = L/R swap enabled 0 = L/R swap disabled.
[1..0]	Rsvd1	R	0	Reserved.

8.11. ADC0 Node (NID = 12)**8.11.1. ADC0 WCap**

	Verb ID	Payload	Response
Get	F00	09	See bitfield table.

8.11.1.1. ADC0 WCap

Bit	Bitfield Name	RW	Reset	Description
[31..24]	Rsvd2	R	00	Reserved.
[23..20]	Type	R	1	Widget type: 0h = Out Converter; 1h = In Converter; 2h = Summing (Mixer); 3h = Selector (Mux); 4h = Pin Complex; 5h = Power; 6h = Volume Knob; 7h = Beep Generator; 8h-Eh = Reserved; Fh = Vendor Defined
[19..16]	Delay	R	D	Number of sample delays through widget.
[15..12]	Rsvd1	R	0	Reserved.

8.11.1.1. *ADC0 WCap*

Bit	Bitfield Name	RW	Reset	Description
[11]	SwapCap	R	0	Left/right swap support: 1 = yes 0 = no.
[10]	PwrCntrl	R	1	Power state support: 1 = yes 0 = no.
[9]	Dig	R	0	Digital stream support: 1 = yes (digital) 0 = no (analog).
[8]	ConnList	R	1	Connection list present: 1 = yes 0 = no.
[7]	UnSolCap	R	0	Unsolicited response support: 1 = yes 0 = no.
[6]	ProcWidget	R	1	Processing state support: 1 = yes 0 = no.
[5]	Stripe	R	0	Striping support: 1 = yes 0 = no.
[4]	FormatOvrd	R	0	Stream format override: 1 = yes 0 = no.
[3]	AmpParOvrd	R	0	Amplifier capabilities override: 1 = yes no.
[2]	OutAmpPrsnt	R	0	Output amp present: 1 = yes 0 = no.
[1]	InAmpPrsnt	R	0	Input amp present: 1 = yes 0 = no.
[0]	Stereo	R	1	Stereo stream support: 1 = yes (stereo) 0 = no (mono).

8.11.2. *ADC0 ConLst*

	Verb ID	Payload	Response
Get	F00	0E	See bitfield table.

8.11.2.1. *ADC0 ConLst*

Bit	Bitfield Name	RW	Reset	Description
[31..8]	Rsvd	R	000000	Reserved.
[7]	LForm	R	0	Connection list format: 1 = long-form (15-bit) NID entries 0 = short-form (7-bit) NID entries.
[6..0]	ConL	R	01	Number of NID entries in connection list.

8.11.3. *ADC0 ConLstEntry0*

	Verb ID	Payload	Response
Get	F02	00	See bitfield table.

8.11.3.1. *ADC0 ConLstEntry0*

Bit	Bitfield Name	RW	Reset	Description
[31..24]	ConL3	R	00	Unused list entry.
[23..16]	ConL2	R	00	Unused list entry.
[15..8]	ConL1	R	00	Unused list entry.
[7..0]	ConL0	R	1C	ADC0Mux Selector widget (0x1C)

8.11.4. *ADC0 Cnvtr*

	Verb ID	Payload	Response
Get	A	0000	See bitfield table.

8.11.4.1. *ADC0 Cnvtr*

Bit	Bitfield Name	RW	Reset	Description
[31..16]	Rsvd2	R	0000	Reserved.
[15]	StrmType	R	0	Stream type: 1 = Non-PCM 0 = PCM.
[14]	FrmtSmplRate	RW	0	Sample base rate: 1 = 44.1kHz 0 = 48kHz.
[13..11]	SmplRateMultp	RW	0	Sample base rate multiple: 000b= x1 (48kHz/44.1kHz or less); 001b= x2 (96kHz/88.2kHz/32kHz); 010b= x3 (144kHz); 011b= x4 (192kHz/176.4kHz); 100b-111b Reserved
[10..8]	SmplRateDiv	RW	0	Sample base rate divider: 000b= Divide by 1 (48kHz/44.1kHz); 001b= Divide by 2 (24kHz/20.05kHz); 010b= Divide by 3 (16kHz/32kHz); 011b= Divide by 4 (11.025kHz); 100b= Divide by 5 (9.6kHz); 101b= Divide by 6 (8kHz); 110b= Divide by 7; 111b= Divide by 8 (6kHz)
[7]	Rsvd1	R	0	Reserved.
[6..4]	BitsPerSmpl	RW	3	Bits per sample: 000b= 8 bits; 001b= 16 bits; 010b= 20 bits; 011b= 24 bits; 100b= 32 bits; 101b-111b= Reserved
[3..0]	NmbrChan	RW	1	Total number of channels in the stream assigned to this converter: 0000b-1111b= 1-16 channels.

8.11.5. *ADC0 ProcState*

	Verb ID	Payload	Response
Get	F03	00	See bitfield table.

8.11.5.1. ADC0 ProcState

Bit	Bitfield Name	RW	Reset	Description
[31..8]	Rsvd2	R	000000	Reserved.
[7]	HPFOCDIS	RW	0	HPF offset calculation disable. 1 = calculation disabled; 0 = calculation enabled.
[6..2]	Rsvd1	R	00	Reserved.
[1..0]	ADCHPFByP	RW	1	Processing State: 00b= bypass the ADC HPF ("off") 01b-11b= ADC HPF is enabled ("on" or "benign").

8.11.6. ADC0 PwrState

	Verb ID	Payload	Response
Get	F05	00	See bitfield table.

8.11.6.1. ADC0 PwrState

Bit	Bitfield Name	RW	Reset	Description
[31..6]	Rsvd2	R	0000000	Reserved.
[5..4]	Act	R	3	Actual power state of this widget.
[3..2]	Rsvd1	R	0	Reserved.
[1..0]	Set	RW	3	Current power state setting for this widget.

8.11.7. ADC0 CnvtrID

	Verb ID	Payload	Response
Get	F06	00	See bitfield table.

8.11.7.1. *ADC0 CnvtrID*

Bit	Bitfield Name	RW	Reset	Description
[31.:8]	Rsvd	R	000000	Reserved.
[7.:4]	Strm	RW	0	Stream ID: 0h = Converter "off" 1h-Fh = valid IDs.
[3.:0]	Ch	RW	0	Channel assignment ("Ch" and "Ch+1" assigned as a pair for a stereo converter).

8.12. ADC1 Node (NID = 13)

8.12.1. *ADC1 WCap*

	Verb ID	Payload	Response
Get	F00	09	See bitfield table.

8.12.1.1. *ADC1 WCap*

Bit	Bitfield Name	RW	Reset	Description
[31.:24]	Rsvd2	R	00	Reserved.
[23.:20]	Type	R	1	Widget type: 0h = Out Converter; 1h = In Converter; 2h = Summing (Mixer); 3h = Selector (Mux); 4h = Pin Complex; 5h = Power; 6h = Volume Knob; 7h = Beep Generator; 8h-Eh = Reserved; Fh = Vendor Defined
[19.:16]	Delay	R	D	Number of sample delays through widget.
[15.:12]	Rsvd1	R	0	Reserved.
[11]	SwapCap	R	0	Left/right swap support: 1 = yes 0 = no.
[10]	PwrCntrl	R	1	Power state support: 1 = yes 0 = no.

8.12.1.1. *ADC1 WCap*

Bit	Bitfield Name	RW	Reset	Description
[9]	Dig	R	0	Digital stream support: 1 = yes (digital) 0 = no (analog).
[8]	ConnList	R	1	Connection list present: 1 = yes 0 = no.
[7]	UnSolCap	R	0	Unsolicited response support: 1 = yes 0 = no.
[6]	ProcWidget	R	1	Processing state support: 1 = yes 0 = no.
[5]	Stripe	R	0	Striping support: 1 = yes 0 = no.
[4]	FormatOvrd	R	0	Stream format override: 1 = yes 0 = no.
[3]	AmpParOvrd	R	0	Amplifier capabilities override: 1 = yes no.
[2]	OutAmpPrsnt	R	0	Output amp present: 1 = yes 0 = no.
[1]	InAmpPrsnt	R	0	Input amp present: 1 = yes 0 = no.
[0]	Stereo	R	1	Stereo stream support: 1 = yes (stereo) 0 = no (mono).

8.12.2. *ADC1 ConLst*

	Verb ID	Payload	Response
Get	F00	0E	See bitfield table.

8.12.2.1. *ADC1 ConLst*

Bit	Bitfield Name	RW	Reset	Description
[31..8]	Rsvd	R	000000	Reserved.
[7]	LForm	R	0	Connection list format: 1 = long-form (15-bit) NID entries 0 = short-form (7-bit) NID entries.
[6.:0]	ConL	R	01	Number of NID entries in connection list.

8.12.3. ADC1 ConLstEntry0

	Verb ID	Payload	Response
Get	F02	00	See bitfield table.

8.12.3.1. ADC1 ConLstEntry0

Bit	Bitfield Name	RW	Reset	Description
[31..24]	ConL3	R	00	Unused list entry.
[23..16]	ConL2	R	00	Unused list entry.
[15..8]	ConL1	R	00	Unused list entry.
[7..0]	ConL0	R	1D	ADC1Mux widget (0x1D)

8.12.4. ADC1 Cnvtr

	Verb ID	Payload	Response
Get	A	0000	See bitfield table.

8.12.4.1. ADC1 Cnvtr

Bit	Bitfield Name	RW	Reset	Description
[31..16]	Rsvd2	R	0000	Reserved.
[15]	StrmType	R	0	Stream type: 1 = Non-PCM 0 = PCM.
[14]	FrmtSmplRate	RW	0	Sample base rate: 1 = 44.1kHz 0 = 48kHz.
[13..11]	SmplRateMultp	RW	0	Sample base rate multiple: 000b= x1 (48kHz/44.1kHz or less); 001b= x2 (96kHz/88.2kHz/32kHz); 010b= x3 (144kHz); 011b= x4 (192kHz/176.4kHz); 100b-111b Reserved

8.12.4.1. *ADC1 Cnvtr*

Bit	Bitfield Name	RW	Reset	Description
[10.:8]	SmplRateDiv	RW	0	Sample base rate divider: 000b= Divide by 1 (48kHz/44.1kHz); 001b= Divide by 2 (24kHz/20.05kHz); 010b= Divide by 3 (16kHz/32kHz); 011b= Divide by 4 (11.025kHz); 100b= Divide by 5 (9.6kHz); 101b= Divide by 6 (8kHz); 110b= Divide by 7; 111b= Divide by 8 (6kHz)
[7]	Rsvd1	R	0	Reserved.
[6.:4]	BitsPerSmpl	RW	3	Bits per sample: 000b= 8 bits; 001b= 16 bits; 010b= 20 bits; 011b= 24 bits; 100b= 32 bits; 101b-111b= Reserved
[3.:0]	NmbrChan	RW	1	Total number of channels in the stream assigned to this converter: 0000b-1111b= 1-16 channels.

8.12.5. *ADC1 ProcState*

	Verb ID	Payload	Response
Get	F03	00	See bitfield table.

8.12.5.1. *ADC1 ProcState*

Bit	Bitfield Name	RW	Reset	Description
[31.:8]	Rsvd2	R	000000	Reserved.
[7]	HPFOCDIS	RW	0	HPF offset calculation disable. 1 = calculation disabled; 0 = calculation enabled.
[6.:2]	Rsvd1	R	00	Reserved.
[1.:0]	ADCHPFByp	RW	1	Processing State: 00b= bypass the ADC HPF ("off") 01b-11b= ADC HPF is enabled ("on" or "benign").

8.12.6. ADC1 PwrState

	Verb ID	Payload	Response
Get	F05	00	See bitfield table.

8.12.6.1. ADC1 PwrState

Bit	Bitfield Name	RW	Reset	Description
[31..6]	Rsvd2	R	0000000	Reserved.
[5..4]	Act	R	3	Actual power state of this widget.
[3..2]	Rsvd1	R	0	Reserved.
[1..0]	Set	RW	3	Current power state setting for this widget.

8.12.7. ADC1 CnvtrID

	Verb ID	Payload	Response
Get	F06	00	See bitfield table.

8.12.7.1. ADC1 CnvtrID

Bit	Bitfield Name	RW	Reset	Description
[31..8]	Rsvd	R	000000	Reserved.
[7..4]	Strm	RW	0	Stream ID: 0h = Converter "off" 1h-Fh = valid IDs.
[3..0]	Ch	RW	0	Channel assignment ("Ch" and "Ch+1" assigned as a pair for a stereo converter).

8.13. PCBeep/MonoOut Node (NID = 14)

8.13.1. PCBeep/MonoOut WCap

	Verb ID	Payload	Response
Get	F00	09	See bitfield table.

8.13.1.1. PCBeep/MonoOut WCap

Bit	Bitfield Name	RW	Reset	Description
[31..24]	Rsvd2	R	00	Reserved.
[23..20]	Type	R	4	Widget type: 0h = Out Converter; 1h = In Converter; 2h = Summing (Mixer); 3h = Selector (Mux); 4h = Pin Complex; 5h = Power; 6h = Volume Knob; 7h = Beep Generator; 8h-Eh = Reserved; Fh = Vendor Defined
[19..16]	Delay	R	0	Number of sample delays through widget.
[15..12]	Rsvd1	R	0	Reserved.
[11]	SwapCap	R	0	Left/right swap support: 1 = yes 0 = no.
[10]	PwrCntrl	R	0	Power state support: 1 = yes 0 = no.
[9]	Dig	R	0	Digital stream support: 1 = yes (digital) 0 = no (analog).
[8]	ConnList	R	1	Connection list present: 1 = yes 0 = no.
[7]	UnSolCap	R	0	Unsolicited response support: 1 = yes 0 = no.
[6]	ProcWidget	R	0	Processing state support: 1 = yes 0 = no.
[5]	Stripe	R	0	Striping support: 1 = yes 0 = no.
[4]	FormatOvrd	R	0	Stream format override: 1 = yes 0 = no.
[3]	AmpParOvrd	R	0	Amplifier capabilities override: 1 = yes no.
[2]	OutAmpPrsnt	R	0	Output amp present: 1 = yes 0 = no.

8.13.1.1. *PCBeep/MonoOut WCap*

Bit	Bitfield Name	RW	Reset	Description
[1]	InAmpPrsnt	R	1	Input amp present: 1 = yes 0 = no.
[0]	Stereo	R	0	Stereo stream support: 1 = yes (stereo) 0 = no (mono).

8.13.2. *PCBeep/MonoOut PinCap*

	Verb ID	Payload	Response
Get	F00	0C	See bitfield table.

8.13.2.1. *PCBeep/MonoOut PinCap*

Bit	Bitfield Name	RW	Reset	Description
[31.:17]	Rsvd2	R	0000	Reserved.
[16]	EapdCap	R	0	EAPD support: 1 = yes 0 = no.
[15.:8]	VrefCntrl	R	00	Vref support: bit 7 = Reserved; bit 6 = Reserved; bit 5 = 100% support (1 = yes 0 = no); bit 4 = 80% support (1 = yes 0 = no); bit 3 = Reserved; bit 2 = GND support (1 = yes 0 = no); bit 1 = 50% support (1 = yes 0 = no); bit 0 = Hi-Z support (1 = yes 0 = no)
[7]	Rsvd1	R	0	Reserved.
[6]	BalancedIO	R	0	Balanced I/O support: 1 = yes 0 = no.
[5]	InCap	R	1	Input support: 1 = yes 0 = no.
[4]	OutCap	R	1	Output support: 1 = yes 0 = no.
[3]	HdphDrvCap	R	0	Headphone amp present: 1 = yes 0 = no.
[2]	PresDtctCap	R	0	Presence detection support: 1 = yes 0 = no.

8.13.2.1. *PCBeep/MonoOut PinCap*

Bit	Bitfield Name	RW	Reset	Description
[1]	TrigRqd	R	0	Trigger required for impedance sense: 1 = yes 0 = no.
[0]	ImpSenseCap	R	0	Impedance sense support: 1 = yes 0 = no.

8.13.3. *PCBeep/MonoOut ConLst*

	Verb ID	Payload	Response
Get	F00	0E	See bitfield table.

8.13.3.1. *PCBeep/MonoOut ConLst*

Bit	Bitfield Name	RW	Reset	Description
[31..8]	Rsvd	R	000000	Reserved.
[7]	LForm	R	0	Connection list format: 1 = long-form (15-bit) NID entries 0 = short-form (7-bit) NID entries.
[6..0]	ConL	R	01	Number of NID entries in connection list.

8.13.4. *PCBeep/MonoOut ConLstEntry0*

	Verb ID	Payload	Response
Get	F02	00	See bitfield table.

8.13.4.1. *PCBeep/MonoOut ConLstEntry0*

Bit	Bitfield Name	RW	Reset	Description
[31.:24]	ConL3	R	00	Unused list entry.
[23.:16]	ConL2	R	00	Unused list entry.
[15.:8]	ConL1	R	00	Unused list entry.
[7.:0]	ConL0	R	16	MonoMixer Summing widget

8.13.5. *PCBeep/MonoOut PinWCntrl*

	Verb ID	Payload	Response
Get	F07	00	See bitfield table.

8.13.5.1. *PCBeep/MonoOut PinWCntrl*

Bit	Bitfield Name	RW	Reset	Description
[31.:7]	Rsvd2	R	000000	Reserved.
[6]	OutEn	RW	0	Output enable: 1 = enabled 0 = disabled.
[5]	InEn	RW	0	Input enable: 1 = enabled 0 = disabled
[4.:0]	Rsvd1	R	0	Reserved.

8.13.6. *PCBeep/MonoOut InAmpLeft*

	Verb ID	Payload	Response
Get	B00	00	See bitfield table.

8.13.6.1. *PCBeep/MonoOut InAmpLeft*

Bit	Bitfield Name	RW	Reset	Description
[31.:8]	Rsvd2	R	000000	Reserved.
[7]	Mute	RW	1	Amp mute: 1 = muted 0 = not muted.
[6.:0]	Rsvd1	R	00	Reserved.

8.13.7. *PCBeep/MonoOut ConfigDefault*

	Verb ID	Payload	Response
Get	F1C	00	See bitfield table.

8.13.7.1. *PCBeep/MonoOut ConfigDefault*

Bit	Bitfield Name	RW	Reset	Description
[31.:30]	PortConnectivity	RW	1	Port connectivity: 0h = Port complex is connected to a jack; 1h = No physical connection for port; 2h = Fixed function device is attached; 3h = Both jack and internal device attached (info in all other fields refers to integrated device any presence detection refers to jack)
[29.:24]	Location	RW	00	Location. Bits [5..4]: 0h = External on primary chassis; 1h = Internal; 2h = Separate chassis; 3h = Other. Bits [3..0]: 0h = N/A; 1h = Rear; 2h = Front; 3h = Left; 4h = Right; 5h = Top; 6h = Bottom; 7h-9h = Special; Ah-Fh = Reserved
[23.:20]	Device	RW	F	Default device: 0h = Line out; 1h = Speaker; 2h = HP out; 3h = CD; 4h = SPDIF Out; 5h = Digital other out; 6h = Modem line side; 7h = Modem handset side; 8h = Line in; 9h = Aux; Ah = Mic in; Bh = Telephony; Ch = SPDIF In; Dh = Digital other in; Eh = Reserved; Fh = Other

8.13.7.1. *PCBeep/MonoOut ConfigDefault*

Bit	Bitfield Name	RW	Reset	Description
[19..16]	ConnectionType	RW	0	Connection type: 0h = Unknown; 1h = 1/8" stereo/mono; 2h = 1/4" stereo/mono; 3h = ATAPI internal; 4h = RCA; 5h = Optical; 6h = Other digital; 7h = Other analog; 8h = Multichannel analog (DIN); 9h = XLR/Professional; Ah = RJ-11 (modem); Bh = Combination; Ch-Eh = Reserved; Fh = Other
[15..12]	Color	RW	0	Color: 0h = Unknown; 1h = Black; 2h = Grey; 3h = Blue; 4h = Green; 5h = Red; 6h = Orange; 7h = Yellow; 8h = Purple; 9h = Pink; Ah-Dh = Reserved; Eh = White; Fh = Other
[11..8]	Misc	RW	0	Miscellaneous: Bits [3..1] = Reserved; Bit 0 = Jack detect override
[7..4]	Association	RW	F	Default association.
[3..0]	Sequence	RW	0	Sequence.

8.14. MonoMux Node (NID = 15)

8.14.1. *MonoMux WCap*

	Verb ID	Payload	Response
Get	F00	09	See bitfield table.

8.14.1.1. *MonoMux WCap*

Bit	Bitfield Name	RW	Reset	Description
[31..24]	Rsvd2	R	00	Reserved.
[23..20]	Type	R	3	Widget type: 0h = Out Converter; 1h = In Converter; 2h = Summing (Mixer); 3h = Selector (Mux); 4h = Pin Complex; 5h = Power; 6h = Volume Knob; 7h = Beep Generator; 8h-Eh = Reserved; Fh = Vendor Defined

8.14.1.1. *MonoMux WCap*

Bit	Bitfield Name	RW	Reset	Description
[19.:16]	Delay	R	0	Number of sample delays through widget.
[15.:12]	Rsvd1	R	0	Reserved.
[11]	SwapCap	R	0	Left/right swap support: 1 = yes 0 = no.
[10]	PwrCntrl	R	0	Power state support: 1 = yes 0 = no.
[9]	Dig	R	0	Digital stream support: 1 = yes (digital) 0 = no (analog).
[8]	ConnList	R	1	Connection list present: 1 = yes 0 = no.
[7]	UnSolCap	R	0	Unsolicited response support: 1 = yes 0 = no.
[6]	ProcWidget	R	0	Processing state support: 1 = yes 0 = no.
[5]	Stripe	R	0	Striping support: 1 = yes 0 = no.
[4]	FormatOvrd	R	0	Stream format override: 1 = yes 0 = no.
[3]	AmpParOvrd	R	0	Amplifier capabilities override: 1 = yes no.
[2]	OutAmpPrsnt	R	0	Output amp present: 1 = yes 0 = no.
[1]	InAmpPrsnt	R	0	Input amp present: 1 = yes 0 = no.
[0]	Stereo	R	1	Stereo stream support: 1 = yes (stereo) 0 = no (mono).

8.14.2. *MonoMux ConLst*

	Verb ID	Payload	Response
Get	F00	0E	See bitfield table.

8.14.2.1. MonoMux ConLst

Bit	Bitfield Name	RW	Reset	Description
[31..8]	Rsvd	R	000000	Reserved.
[7]	LForm	R	0	Connection list format: 1 = long-form (15-bit) NID entries 0 = short-form (7-bit) NID entries.
[6..0]	ConL	R	03	Number of NID entries in connection list.

8.14.3. MonoMux ConLstEntry0

	Verb ID	Payload	Response
Get	F02	00	See bitfield table.

8.14.3.1. MonoMux ConLstEntry0

Bit	Bitfield Name	RW	Reset	Description
[31..24]	ConL3	R	00	Unused list entry.
[23..16]	ConL2	R	17	Input Mixer widget (0x17)
[15..8]	ConL1	R	11	DAC1 Converter widget (0x11)
[7..0]	ConL0	R	10	DAC0 Converter widget (0x10)

8.14.4. MonoMux ConSelectCtrl

	Verb ID	Payload	Response
Get	F01	00	See bitfield table.

8.14.4.1. MonoMux ConSelectCtrl

Bit	Bitfield Name	RW	Reset	Description
[31..:2]	Rsvd	R	0000000	Reserved.
[1..:0]	Index	RW	0	Connection select control index.

8.15. MonoMixer Node (NID = 16)

8.15.1. MonoMixer WCap

	Verb ID	Payload	Response
Get	F00	09	See bitfield table.

8.15.1.1. MonoMixer WCap

Bit	Bitfield Name	RW	Reset	Description
[31..:24]	Rsvd2	R	00	Reserved.
[23..:20]	Type	R	2	Widget type: 0h = Out Converter; 1h = In Converter; 2h = Summing (Mixer); 3h = Selector (Mux); 4h = Pin Complex; 5h = Power; 6h = Volume Knob; 7h = Beep Generator; 8h-Eh = Reserved; Fh = Vendor Defined
[19..:16]	Delay	R	0	Number of sample delays through widget.
[15..:12]	Rsvd1	R	0	Reserved.
[11]	SwapCap	R	0	Left/right swap support: 1 = yes 0 = no.
[10]	PwrCntrl	R	0	Power state support: 1 = yes 0 = no.
[9]	Dig	R	0	Digital stream support: 1 = yes (digital) 0 = no (analog).
[8]	ConnList	R	1	Connection list present: 1 = yes 0 = no.

8.15.1.1. *MonoMixer WCap*

Bit	Bitfield Name	RW	Reset	Description
[7]	UnSolCap	R	0	Unsolicited response support: 1 = yes 0 = no.
[6]	ProcWidget	R	0	Processing state support: 1 = yes 0 = no.
[5]	Stripe	R	0	Striping support: 1 = yes 0 = no.
[4]	FormatOvrd	R	0	Stream format override: 1 = yes 0 = no.
[3]	AmpParOvrd	R	0	Amplifier capabilities override: 1 = yes no.
[2]	OutAmpPrsnt	R	0	Output amp present: 1 = yes 0 = no.
[1]	InAmpPrsnt	R	0	Input amp present: 1 = yes 0 = no.
[0]	Stereo	R	0	Stereo stream support: 1 = yes (stereo) 0 = no (mono).

8.15.2. *MonoMixer ConLst*

	Verb ID	Payload	Response
Get	F00	0E	See bitfield table.

8.15.2.1. *MonoMixer ConLst*

Bit	Bitfield Name	RW	Reset	Description
[31.:8]	Rsvd	R	000000	Reserved.
[7]	LForm	R	0	Connection list format: 1 = long-form (15-bit) NID entries 0 = short-form (7-bit) NID entries.
[6.:0]	ConL	R	01	Number of NID entries in connection list.

8.15.3. MonoMixer ConLstEntry0

	Verb ID	Payload	Response
Get	F02	00	See bitfield table.

8.15.3.1. MonoMixer ConLstEntry0

Bit	Bitfield Name	RW	Reset	Description
[31..:24]	ConL3	R	00	Unused list entry.
[23..:16]	ConL2	R	00	Unused list entry.
[15..:8]	ConL1	R	00	Unused list entry.
[7..:0]	ConL0	R	15	MonoMux Selector widget (0x15)

8.16. InputMixer Node (NID = 17)**8.16.1. InputMixer WCap**

	Verb ID	Payload	Response
Get	F00	09	See bitfield table.

8.16.1.1. InputMixer WCap

Bit	Bitfield Name	RW	Reset	Description
[31..:24]	Rsvd2	R	00	Reserved.
[23..:20]	Type	R	2	Widget type: 0h = Out Converter; 1h = In Converter; 2h = Summing (Mixer); 3h = Selector (Mux); 4h = Pin Complex; 5h = Power; 6h = Volume Knob; 7h = Beep Generator; 8h-Eh = Reserved; Fh = Vendor Defined
[19..:16]	Delay	R	0	Number of sample delays through widget.

8.16.1.1. *InputMixer WCap*

Bit	Bitfield Name	RW	Reset	Description
[15.:12]	Rsvd1	R	0	Reserved.
[11]	SwapCap	R	0	Left/right swap support: 1 = yes 0 = no.
[10]	PwrCntrl	R	0	Power state support: 1 = yes 0 = no.
[9]	Dig	R	0	Digital stream support: 1 = yes (digital) 0 = no (analog).
[8]	ConnList	R	1	Connection list present: 1 = yes 0 = no.
[7]	UnSolCap	R	0	Unsolicited response support: 1 = yes 0 = no.
[6]	ProcWidget	R	0	Processing state support: 1 = yes 0 = no.
[5]	Stripe	R	0	Striping support: 1 = yes 0 = no.
[4]	FormatOvrd	R	0	Stream format override: 1 = yes 0 = no.
[3]	AmpParOvrd	R	1	Amplifier capabilities override: 1 = yes no.
[2]	OutAmpPrsnt	R	0	Output amp present: 1 = yes 0 = no.
[1]	InAmpPrsnt	R	1	Input amp present: 1 = yes 0 = no.
[0]	Stereo	R	1	Stereo stream support: 1 = yes (stereo) 0 = no (mono).

8.16.2. *InputMixer ConLst*

	Verb ID	Payload	Response
Get	F00	0E	See bitfield table.

8.16.2.1. *InputMixer ConLst*

Bit	Bitfield Name	RW	Reset	Description
[31..8]	Rsvd	R	000000	Reserved.
[7]	LForm	R	0	Connection list format: 1 = long-form (15-bit) NID entries 0 = short-form (7-bit) NID entries.
[6..0]	ConL	R	05	Number of NID entries in connection list.

8.16.3. *InputMixer ConLstEntry4*

	Verb ID	Payload	Response
Get	F02	04	See bitfield table.

8.16.3.1. *InputMixer ConLstEntry4*

Bit	Bitfield Name	RW	Reset	Description
[31..24]	ConL7	R	00	Unused list entry.
[23..16]	ConL6	R	00	Unused list entry.
[15..8]	ConL5	R	00	Unused list entry.
[7..0]	ConL4	R	1B	InPort1Mux Selector widget (0x1B). Uses InAmpLeft4/InAmpRight4 controls.

8.16.4. *InputMixer ConLstEntry0*

	Verb ID	Payload	Response
Get	F02	00	See bitfield table.

8.16.4.1. *InputMixer ConLstEntry0*

Bit	Bitfield Name	RW	Reset	Description
[31.:24]	ConL3	R	1A	InPort0Mux Selector widget (0x1A). Uses InAmpLeft3/InAmpRight3 controls.
[23.:16]	ConL2	R	14	AnaBeep Pin widget (0x14). Uses InAmpLeft2/InAmpRight2 controls.
[15.:8]	ConL1	R	11	DAC1 Converter widget (0x11). Uses InAmpLeft1/InAmpRight1 controls.
[7.:0]	ConL0	R	10	DAC0 Converter widget (0x10). Uses InAmpLeft0/InAmpRight0 controls.

8.16.5. *InputMixer InAmpCap*

	Verb ID	Payload	Response
Get	F00	0D	See bitfield table.

8.16.5.1. *InputMixer InAmpCap*

Bit	Bitfield Name	RW	Reset	Description
[31]	Mute	R	1	Mute support: 1 = yes 0 = no.
[30.:23]	Rsvd3	R	00	Reserved.
[22.:16]	StepSize	R	05	Size of each step in the gain range: 0 to 127 = .25dB to 32dB in .25dB steps.
[15]	Rsvd2	R	0	Reserved.
[14.:8]	NumSteps	R	1F	Number of gains steps (number of possible settings - 1).
[7]	Rsvd1	R	0	Reserved.
[6.:0]	Offset	R	17	Indicates which step is 0dB

8.16.6. InputMixer InAmpLeft0

	Verb ID	Payload	Response
Get	B20	00	See bitfield table.

8.16.6.1. InputMixer InAmpLeft0

Bit	Bitfield Name	RW	Reset	Description
[31..8]	Rsvd2	R	000000	Reserved.
[7]	Mute	RW	1	Amp mute: 1 = muted 0 = not muted.
[6..5]	Rsvd1	R	0	Reserved.
[4..0]	Gain	RW	17	Amp gain step number (see InAmpCap parameter pertaining to this widget).

8.16.7. InputMixer InAmpRight0

	Verb ID	Payload	Response
Get	B00	00	See bitfield table.

8.16.7.1. InputMixer InAmpRight0

Bit	Bitfield Name	RW	Reset	Description
[31..8]	Rsvd2	R	000000	Reserved.
[7]	Mute	RW	1	Amp mute: 1 = muted 0 = not muted.
[6..5]	Rsvd1	R	0	Reserved.
[4..0]	Gain	RW	17	Amp gain step number (see InAmpCap parameter pertaining to this widget).

8.16.8. InputMixer InAmpLeft1

	Verb ID	Payload	Response
Get	B20	01	See bitfield table.

8.16.8.1. InputMixer InAmpLeft1

Bit	Bitfield Name	RW	Reset	Description
[31..8]	Rsvd2	R	000000	Reserved.
[7]	Mute	RW	1	Amp mute: 1 = muted 0 = not muted.
[6..5]	Rsvd1	R	0	Reserved.
[4..0]	Gain	RW	17	Amp gain step number (see InAmpCap parameter pertaining to this widget).

8.16.9. InputMixer InAmpRight1

	Verb ID	Payload	Response
Get	B00	01	See bitfield table.

8.16.9.1. InputMixer InAmpRight1

Bit	Bitfield Name	RW	Reset	Description
[31..8]	Rsvd2	R	000000	Reserved.
[7]	Mute	RW	1	Amp mute: 1 = muted 0 = not muted.
[6..5]	Rsvd1	R	0	Reserved.
[4..0]	Gain	RW	17	Amp gain step number (see InAmpCap parameter pertaining to this widget).

8.16.10. InputMixer InAmpLeft2

	Verb ID	Payload	Response
Get	B20	02	See bitfield table.

8.16.10.1. InputMixer InAmpLeft2

Bit	Bitfield Name	RW	Reset	Description
[31..8]	Rsvd2	R	000000	Reserved.
[7]	Mute	RW	1	Amp mute: 1 = muted 0 = not muted.
[6..5]	Rsvd1	R	0	Reserved.
[4..0]	Gain	RW	17	Amp gain step number (see InAmpCap parameter pertaining to this widget).

8.16.11. InputMixer InAmpRight2

	Verb ID	Payload	Response
Get	B00	02	See bitfield table.

8.16.11.1. InputMixer InAmpRight2

Bit	Bitfield Name	RW	Reset	Description
[31..8]	Rsvd2	R	000000	Reserved.
[7]	Mute	RW	1	Amp mute: 1 = muted 0 = not muted.
[6..5]	Rsvd1	R	0	Reserved.
[4..0]	Gain	RW	17	Amp gain step number (see InAmpCap parameter pertaining to this widget).

8.16.12. InputMixer InAmpLeft3

	Verb ID	Payload	Response
Get	B20	03	See bitfield table.

8.16.12.1. InputMixer InAmpLeft3

Bit	Bitfield Name	RW	Reset	Description
[31..8]	Rsvd2	R	000000	Reserved.
[7]	Mute	RW	1	Amp mute: 1 = muted 0 = not muted.
[6..5]	Rsvd1	R	0	Reserved.
[4..0]	Gain	RW	17	Amp gain step number (see InAmpCap parameter pertaining to this widget).

8.16.13. InputMixer InAmpRight3

	Verb ID	Payload	Response
Get	B00	03	See bitfield table.

8.16.13.1. InputMixer InAmpRight3

Bit	Bitfield Name	RW	Reset	Description
[31..8]	Rsvd2	R	000000	Reserved.
[7]	Mute	RW	1	Amp mute: 1 = muted 0 = not muted.
[6..5]	Rsvd1	R	0	Reserved.
[4..0]	Gain	RW	17	Amp gain step number (see InAmpCap parameter pertaining to this widget).

8.16.14. InputMixer InAmpLeft4

	Verb ID	Payload	Response
Get	B20	04	See bitfield table.

8.16.14.1. InputMixer InAmpLeft4

Bit	Bitfield Name	RW	Reset	Description
[31..8]	Rsvd2	R	000000	Reserved.
[7]	Mute	RW	1	Amp mute: 1 = muted 0 = not muted.
[6..5]	Rsvd1	R	0	Reserved.
[4..0]	Gain	RW	17	Amp gain step number (see InAmpCap parameter pertaining to this widget).

8.16.15. InputMixer InAmpRight4

	Verb ID	Payload	Response
Get	B00	04	See bitfield table.

8.16.15.1. InputMixer InAmpRight4

Bit	Bitfield Name	RW	Reset	Description
[31..8]	Rsvd2	R	000000	Reserved.
[7]	Mute	RW	1	Amp mute: 1 = muted 0 = not muted.
[6..5]	Rsvd1	R	0	Reserved.
[4..0]	Gain	RW	17	Amp gain step number (see InAmpCap parameter pertaining to this widget).

8.17. DMic0 Node (NID = 18)

8.17.1. DMic0 WCap

	Verb ID	Payload	Response
Get	F00	09	See bitfield table.

8.17.1.1. DMic0 WCap

Bit	Bitfield Name	RW	Reset	Description
[31.:24]	Rsvd2	R	00	Reserved.
[23.:20]	Type	R	4	Widget type: 0h = Out Converter; 1h = In Converter; 2h = Summing (Mixer); 3h = Selector (Mux); 4h = Pin Complex; 5h = Power; 6h = Volume Knob; 7h = Beep Generator; 8h-Eh = Reserved; Fh = Vendor Defined
[19.:16]	Delay	R	0	Number of sample delays through widget.
[15.:12]	Rsvd1	R	0	Reserved.
[11]	SwapCap	R	0	Left/right swap support: 1 = yes 0 = no.
[10]	PwrCntrl	R	0	Power state support: 1 = yes 0 = no.
[9]	DigitalStrm	R	0	Digital stream support: 1 = yes (digital) 0 = no (analog).
[8]	ConnList	R	0	Connection list present: 1 = yes 0 = no.
[7]	UnsolCap	R	0	Unsolicited response support: 1 = yes 0 = no.
[6]	ProcWidget	R	0	Processing state support: 1 = yes 0 = no.
[5]	Stripe	R	0	Striping support: 1 = yes 0 = no.
[4]	FormatOvrd	R	0	Stream format override: 1 = yes 0 = no.
[3]	AmpParOvrd	R	1	Amplifier capabilities override: 1 = yes no.
[2]	OutAmpPrsnt	R	0	Output amp present: 1 = yes 0 = no.

8.17.1.1. *DMic0 WCap*

Bit	Bitfield Name	RW	Reset	Description
[1]	InAmpPrsnt	R	1	Input amp present: 1 = yes 0 = no.
[0]	Stereo	R	1	Stereo stream support: 1 = yes (stereo) 0 = no (mono).

8.17.2. *DMic0 PinCap*

	Verb ID	Payload	Response
Get	F00	0C	See bitfield table.

8.17.2.1. *DMic0 PinCap*

Bit	Bitfield Name	RW	Reset	Description
[31.:17]	Rsvd2	R	0000	Reserved.
[16]	EapdCap	R	0	EAPD support: 1 = yes 0 = no.
[15.:8]	VRefCntrl	R	00	Vref support: bit 7 = Reserved; bit 6 = Reserved; bit 5 = 100% support (1 = yes 0 = no); bit 4 = 80% support (1 = yes 0 = no); bit 3 = Reserved; bit 2 = GND support (1 = yes 0 = no); bit 1 = 50% support (1 = yes 0 = no); bit 0 = Hi-Z support (1 = yes 0 = no)
[7]	Rsvd1	R	0	Reserved.
[6]	BalancedIO	R	0	Balanced I/O support: 1 = yes 0 = no.
[5]	InCap	R	1	Input support: 1 = yes 0 = no.
[4]	OutCap	R	0	Output support: 1 = yes 0 = no.
[3]	HPhnDrvCap	R	0	Headphone amp present: 1 = yes 0 = no.
[2]	PresDtctCap	R	0	Presence detection support: 1 = yes 0 = no.

8.17.2.1. *DMic0 PinCap*

Bit	Bitfield Name	RW	Reset	Description
[1]	TrigRqd	R	0	Trigger required for impedance sense: 1 = yes 0 = no.
[0]	ImpSenseCap	R	0	Impedance sense support: 1 = yes 0 = no.

8.17.3. *DMic0 PinWCntrl*

	Verb ID	Payload	Response
Get	F07	00	See bitfield table.

8.17.3.1. *DMic0 PinWCntrl*

Bit	Bitfield Name	RW	Reset	Description
[31..6]	Rsvd2	R	0000000	Reserved.
[5]	InEn	RW	0	Input enable: 1 = enabled 0 = disabled.
[4..0]	Rsvd1	R	00	Reserved.

8.17.4. *DMic0 InAmpCap*

	Verb ID	Payload	Response
Get	F00	0D	See bitfield table.

8.17.4.1. *DMic0 InAmpCap*

Bit	Bitfield Name	RW	Reset	Description
[31]	Mute	R	0	Mute support: 1 = yes 0 = no.
[30..23]	Rsvd3	R	00	Reserved.

8.17.4.1. *DMic0 InAmpCap*

Bit	Bitfield Name	RW	Reset	Description
[22..16]	StepSize	R	27	Size of each step in the gain range: 0 to 127 = .25dB to 32dB in .25dB steps.
[15]	Rsvd2	R	0	Reserved.
[14..8]	NumSteps	R	03	Number of gains steps (number of possible settings - 1).
[7]	Rsvd1	R	0	Reserved.
[6..0]	Offset	R	00	Indicates which step is 0dB

8.17.5. *DMic0 InAmpLeft*

	Verb ID	Payload	Response
Get	B2	00	See bitfield table.

8.17.5.1. *DMic0 InAmpLeft*

Bit	Bitfield Name	RW	Reset	Description
[31..3]	Rsvd1	R	00000000	Reserved.
[2..0]	Gain	RW	0	Amp gain step number (see OutAmp-Cap parameter pertaining to this widget).

8.17.6. *DMic0 InAmpRight*

	Verb ID	Payload	Response
Get	B00	00	See bitfield table.

8.17.6.1. *In0 OutAmpRight*

Bit	Bitfield Name	RW	Reset	Description
[31..3]	Rsvd1	R	00000000	Reserved.
[2..0]	Gain	RW	0	Amp gain step number (see OutAmp-Cap parameter pertaining to this widget).

8.17.7. *DMic0 ConfigDefault*

	Verb ID	Payload	Response
Get	F1C	00	See bitfield table.

8.17.7.1. *DMic0 ConfigDefault*

Bit	Bitfield Name	RW	Reset	Description
[31..30]	PortConnectivity	RW	1	Port connectivity: 0h = Port complex is connected to a jack; 1h = No physical connection for port; 2h = Fixed function device is attached; 3h = Both jack and internal device attached (info in all other fields refers to integrated device any presence detection refers to jack)
[29..24]	Location	RW	00	Location. Bits [5..4]: 0h = External on primary chassis; 1h = Internal; 2h = Separate chassis; 3h = Other. Bits [3..0]: 0h = N/A; 1h = Rear; 2h = Front; 3h = Left; 4h = Right; 5h = Top; 6h = Bottom; 7h-9h = Special; Ah-Fh = Reserved
[23..20]	Device	RW	F	Default device: 0h = Line out; 1h = Speaker; 2h = HP out; 3h = CD; 4h = SPDIF Out; 5h = Digital other out; 6h = Modem line side; 7h = Modem handset side; 8h = Line in; 9h = Aux; Ah = Mic in; Bh = Telephony; Ch = SPDIF In; Dh = Digital other in; Eh = Reserved; Fh = Other

8.17.7.1. *DMic0 ConfigDefault*

Bit	Bitfield Name	RW	Reset	Description
[19.:16]	ConnectionType	RW	0	Connection type: 0h = Unknown; 1h = 1/8" stereo/mono; 2h = 1/4" stereo/mono; 3h = ATAPI internal; 4h = RCA; 5h = Optical; 6h = Other digital; 7h = Other analog; 8h = Multichannel analog (DIN); 9h = XLR/Professional; Ah = RJ-11 (modem); Bh = Combination; Ch-Eh = Reserved; Fh = Other
[15.:12]	Color	RW	0	Color: 0h = Unknown; 1h = Black; 2h = Grey; 3h = Blue; 4h = Green; 5h = Red; 6h = Orange; 7h = Yellow; 8h = Purple; 9h = Pink; Ah-Dh = Reserved; Eh = White; Fh = Other
[11.:8]	Misc	RW	0	Miscellaneous: Bits [3..1] = Reserved; Bit 0 = Jack detect override
[7.:4]	Association	RW	F	Default association.
[3.:0]	Sequence	RW	0	Sequence.

8.18. **DMic1 Node (NID = 19), 48QFN package only**8.18.1. *DMic1 WCap*

	Verb ID	Payload	Response
Get	F00	09	See bitfield table.

8.18.1.1. *DMic1 WCap*

Bit	Bitfield Name	RW	Reset	Description
[31.:24]	Rsvd2	R	00	Reserved.
[23.:20]	Type	R	4	Widget type: 0h = Out Converter; 1h = In Converter; 2h = Summing (Mixer); 3h = Selector (Mux); 4h = Pin Complex; 5h = Power; 6h = Volume Knob; 7h = Beep Generator; 8h-Eh = Reserved; Fh = Vendor Defined

8.18.1.1. *DMic1 WCap*

Bit	Bitfield Name	RW	Reset	Description
[19.:16]	Delay	R	0	Number of sample delays through widget.
[15.:12]	Rsvd1	R	0	Reserved.
[11]	SwapCap	R	0	Left/right swap support: 1 = yes 0 = no.
[10]	PwrCntrl	R	0	Power state support: 1 = yes 0 = no.
[9]	DigitalStrm	R	0	Digital stream support: 1 = yes (digital) 0 = no (analog).
[8]	ConnList	R	0	Connection list present: 1 = yes 0 = no.
[7]	UnsolCap	R	0	Unsolicited response support: 1 = yes 0 = no.
[6]	ProcWidget	R	0	Processing state support: 1 = yes 0 = no.
[5]	Stripe	R	0	Striping support: 1 = yes 0 = no.
[4]	FormatOvrd	R	0	Stream format override: 1 = yes 0 = no.
[3]	AmpParOvrd	R	1	Amplifier capabilities override: 1 = yes no.
[2]	OutAmpPrsnt	R	0	Output amp present: 1 = yes 0 = no.
[1]	InAmpPrsnt	R	1	Input amp present: 1 = yes 0 = no.
[0]	Stereo	R	1	Stereo stream support: 1 = yes (stereo) 0 = no (mono).

8.18.2. *DMic1 PinCap*

	Verb ID	Payload	Response
Get	F00	0C	See bitfield table.

8.18.2.1. *DMic1 PinCap*

Bit	Bitfield Name	RW	Reset	Description
[31.:17]	Rsvd2	R	0000	Reserved.
[16]	EapdCap	R	0	EAPD support: 1 = yes 0 = no.
[15.:8]	VRefCntrl	R	00	Vref support: bit 7 = Reserved; bit 6 = Reserved; bit 5 = 100% support (1 = yes 0 = no); bit 4 = 80% support (1 = yes 0 = no); bit 3 = Reserved; bit 2 = GND support (1 = yes 0 = no); bit 1 = 50% support (1 = yes 0 = no); bit 0 = Hi-Z support (1 = yes 0 = no)
[7]	Rsvd1	R	0	Reserved.
[6]	BalancedIO	R	0	Balanced I/O support: 1 = yes 0 = no.
[5]	InCap	R	1	Input support: 1 = yes 0 = no.
[4]	OutCap	R	0	Output support: 1 = yes 0 = no.
[3]	HPhnDrvCap	R	0	Headphone amp present: 1 = yes 0 = no.
[2]	PresDtctCap	R	0	Presence detection support: 1 = yes 0 = no.
[1]	TrigRqd	R	0	Trigger required for impedance sense: 1 = yes 0 = no.
[0]	ImpSenseCap	R	0	Impedance sense support: 1 = yes 0 = no.

8.18.3. *DMic1 PinWCntrl*

	Verb ID	Payload	Response
Get	F07	00	See bitfield table.

8.18.3.1. DMic1 PinWCntrl

Bit	Bitfield Name	RW	Reset	Description
[31.:6]	Rsvd2	R	0000000	Reserved.
[5]	InEn	RW	0	Input enable: 1 = enabled 0 = disabled.
[4.:0]	Rsvd1	R	00	Reserved.

8.18.4. DMic1 InAmpCap

	Verb ID	Payload	Response
Get	F00	0D	See bitfield table.

8.18.4.1. DMic1 InAmpCap

Bit	Bitfield Name	RW	Reset	Description
[31]	Mute	R	0	Mute support: 1 = yes 0 = no.
[30.:23]	Rsvd3	R	00	Reserved.
[22.:16]	StepSize	R	27	Size of each step in the gain range: 0 to 127 = .25dB to 32dB in .25dB steps.
[15]	Rsvd2	R	0	Reserved.
[14.:8]	NumSteps	R	03	Number of gains steps (number of possible settings - 1).
[7]	Rsvd1	R	0	Reserved.
[6.:0]	Offset	R	00	Indicates which step is 0dB

8.18.5. DMic1 InAmpLeft

	Verb ID	Payload	Response
Get	B20	00	See bitfield table.

8.18.5.1. DMic1 InAmpLeft

Bit	Bitfield Name	RW	Reset	Description
[31..3]	Rsvd1	R	00000000	Reserved.
[2..0]	Gain	RW	0	Amp gain step number (see OutAmp-Cap parameter pertaining to this widget).

8.18.6. DMic1 InAmpRight

	Verb ID	Payload	Response
Get	B00	00	See bitfield table.

8.18.6.1. DMic1 InAmpRight

Bit	Bitfield Name	RW	Reset	Description
[31..3]	Rsvd1	R	00000000	Reserved.
[2..0]	Gain	RW	0	Amp gain step number (see OutAmp-Cap parameter pertaining to this widget).

8.18.7. DMic1 ConfigDefault

	Verb ID	Payload	Response
Get	F1C	00	See bitfield table.

8.18.7.1. *DMic1 ConfigDefault*

Bit	Bitfield Name	RW	Reset	Description
[31..30]	PortConnectivity	RW	1	Port connectivity: 0h = Port complex is connected to a jack; 1h = No physical connection for port; 2h = Fixed function device is attached; 3h = Both jack and internal device attached (info in all other fields refers to integrated device any presence detection refers to jack)
[29..24]	Location	RW	00	Location. Bits [5..4]: 0h = External on primary chassis; 1h = Internal; 2h = Separate chassis; 3h = Other. Bits [3..0]: 0h = N/A; 1h = Rear; 2h = Front; 3h = Left; 4h = Right; 5h = Top; 6h = Bottom; 7h-9h = Special; Ah-Fh = Reserved
[23..20]	Device	RW	F	Default device: 0h = Line out; 1h = Speaker; 2h = HP out; 3h = CD; 4h = SPDIF Out; 5h = Digital other out; 6h = Modem line side; 7h = Modem handset side; 8h = Line in; 9h = Aux; Ah = Mic in; Bh = Telephony; Ch = SPDIF In; Dh = Digital other in; Eh = Reserved; Fh = Other
[19..16]	ConnectionType	RW	0	Connection type: 0h = Unknown; 1h = 1/8" stereo/mono; 2h = 1/4" stereo/mono; 3h = ATAPI internal; 4h = RCA; 5h = Optical; 6h = Other digital; 7h = Other analog; 8h = Multichannel analog (DIN); 9h = XLR/Professional; Ah = RJ-11 (modem); Bh = Combination; Ch-Eh = Reserved; Fh = Other
[15..12]	Color	RW	0	Color: 0h = Unknown; 1h = Black; 2h = Grey; 3h = Blue; 4h = Green; 5h = Red; 6h = Orange; 7h = Yellow; 8h = Purple; 9h = Pink; Ah-Dh = Reserved; Eh = White; Fh = Other
[11..8]	Misc	RW	0	Miscellaneous: Bits [3..1] = Reserved; Bit 0 = Jack detect override
[7..4]	Association	RW	F	Default association.
[3..0]	Sequence	RW	0	Sequence.

8.19. InPort0Mux Node (NID = 1A)

8.19.1. InPort0Mux WCap

	Verb ID	Payload	Response
Get	F00	09	See bitfield table.

8.19.1.1. InPort0Mux WCap

Bit	Bitfield Name	RW	Reset	Description
[31.:24]	Rsvd2	R	00	Reserved.
[23.:20]	Type	R	3	Widget type: 0h = Out Converter; 1h = In Converter; 2h = Summing (Mixer); 3h = Selector (Mux); 4h = Pin Complex; 5h = Power; 6h = Volume Knob; 7h = Beep Generator; 8h-Eh = Reserved; Fh = Vendor Defined
[19.:16]	Delay	R	0	Number of sample delays through widget.
[15.:12]	Rsvd1	R	0	Reserved.
[11]	SwapCap	R	0	Left/right swap support: 1 = yes 0 = no.
[10]	PwrCntrl	R	0	Power state support: 1 = yes 0 = no.
[9]	Dig	R	0	Digital stream support: 1 = yes (digital) 0 = no (analog).
[8]	ConnList	R	1	Connection list present: 1 = yes 0 = no.
[7]	UnSolCap	R	0	Unsolicited response support: 1 = yes 0 = no.
[6]	ProcWidget	R	0	Processing state support: 1 = yes 0 = no.
[5]	Stripe	R	0	Striping support: 1 = yes 0 = no.
[4]	FormatOvrd	R	0	Stream format override: 1 = yes 0 = no.
[3]	AmpParOvrd	R	1	Amplifier capabilities override: 1 = yes no.
[2]	OutAmpPrsnt	R	1	Output amp present: 1 = yes 0 = no.

8.19.1.1. *InPort0Mux WCap*

Bit	Bitfield Name	RW	Reset	Description
[1]	InAmpPrsnt	R	0	Input amp present: 1 = yes 0 = no.
[0]	Stereo	R	1	Stereo stream support: 1 = yes (stereo) 0 = no (mono).

8.19.2. *InPort0Mux ConLst*

	Verb ID	Payload	Response
Get	F00	0E	See bitfield table.

8.19.2.1. *InPort0Mux ConLst*

Bit	Bitfield Name	RW	Reset	Description
[31..8]	Rsvd	R	000000	Reserved.
[7]	LForm	R	0	Connection list format: 1 = long-form (15-bit) NID entries 0 = short-form (7-bit) NID entries.
[6..0]	ConL	R	03	Number of NID entries in connection list.

8.19.3. *InPort0Mux ConLstEntry0*

	Verb ID	Payload	Response
Get	F02	00	See bitfield table.

8.19.3.1. *InPort0Mux ConLstEntry0*

Bit	Bitfield Name	RW	Reset	Description
[31..24]	ConL3	R	00	Unused list entry.
[23..16]	ConL2	R	0E	Port E Pin widget (0x0E)

8.19.3.1. *InPort0Mux ConLstEntry0*

Bit	Bitfield Name	RW	Reset	Description
[15.:8]	ConL1	R	0C	Port C Pin widget (0x0C)
[7.:0]	ConL0	R	0B	Port B Pin widget (0x0B)

8.19.4. *InPort0Mux ConSelectCtrl*

	Verb ID	Payload	Response
Get	F01	00	See bitfield table.

8.19.4.1. *InPort0Mux ConSelectCtrl*

Bit	Bitfield Name	RW	Reset	Description
[31.:2]	Rsvd	R	00000000	Reserved.
[1.:0]	Index	RW	0	Connection select control index.

8.19.5. *InPort0Mux OutAmpCap*

	Verb ID	Payload	Response
Get	F00	12	See bitfield table.

8.19.5.1. *InPort0Mux OutAmpCap*

Bit	Bitfield Name	RW	Reset	Description
[31]	Mute	R	0	Mute support: 1 = yes 0 = no.
[30.:23]	Rsvd3	R	00	Reserved.
[22.:16]	StepSize	R	27	Size of each step in the gain range: 0 to 127 = .25dB to 32dB in .25dB steps.
[15]	Rsvd2	R	0	Reserved.

8.19.5.1. *InPort0Mux OutAmpCap*

Bit	Bitfield Name	RW	Reset	Description
[14.:8]	NumSteps	R	03	Number of gains steps (number of possible settings - 1).
[7]	Rsvd1	R	0	Reserved.
[6.:0]	Offset	R	00	Indicates which step is 0dB

8.19.6. *InPort0Mux OutAmpLeft*

	Verb ID	Payload	Response
Get	BA0	00	See bitfield table.

8.19.6.1. *InPort0Mux OutAmpLeft*

Bit	Bitfield Name	RW	Reset	Description
[31.:3]	Rsvd1	R	00000000	Reserved.
[2.:0]	Gain	RW	0	Amp gain step number (see OutAmp-Cap parameter pertaining to this widget).

8.19.7. *InPort0Mux OutAmpRight*

	Verb ID	Payload	Response
Get	B80	00	See bitfield table.

8.19.7.1. *InPort0Mux OutAmpRight*

Bit	Bitfield Name	RW	Reset	Description
[31.:3]	Rsvd1	R	00000000	Reserved.
[2.:0]	Gain	RW	0	Amp gain step number (see OutAmp-Cap parameter pertaining to this widget).

8.20. InPort1Mux Node (NID = 1B)

8.20.1. *InPort1Mux WCap*

	Verb ID	Payload	Response
Get	F00	09	See bitfield table.

8.20.1.1. *InPort1Mux WCap*

Bit	Bitfield Name	RW	Reset	Description
[31.:24]	Rsvd2	R	00	Reserved.
[23.:20]	Type	R	3	Widget type: 0h = Out Converter; 1h = In Converter; 2h = Summing (Mixer); 3h = Selector (Mux); 4h = Pin Complex; 5h = Power; 6h = Volume Knob; 7h = Beep Generator; 8h-Eh = Reserved; Fh = Vendor Defined
[19.:16]	Delay	R	0	Number of sample delays through widget.
[15.:12]	Rsvd1	R	0	Reserved.
[11]	SwapCap	R	0	Left/right swap support: 1 = yes 0 = no.
[10]	PwrCntrl	R	0	Power state support: 1 = yes 0 = no.
[9]	Dig	R	0	Digital stream support: 1 = yes (digital) 0 = no (analog).
[8]	ConnList	R	1	Connection list present: 1 = yes 0 = no.

8.20.1.1. *InPort1Mux WCap*

Bit	Bitfield Name	RW	Reset	Description
[7]	UnSolCap	R	0	Unsolicited response support: 1 = yes 0 = no.
[6]	ProcWidget	R	0	Processing state support: 1 = yes 0 = no.
[5]	Stripe	R	0	Striping support: 1 = yes 0 = no.
[4]	FormatOvrd	R	0	Stream format override: 1 = yes 0 = no.
[3]	AmpParOvrd	R	1	Amplifier capabilities override: 1 = yes no.
[2]	OutAmpPrsnt	R	1	Output amp present: 1 = yes 0 = no.
[1]	InAmpPrsnt	R	0	Input amp present: 1 = yes 0 = no.
[0]	Stereo	R	1	Stereo stream support: 1 = yes (stereo) 0 = no (mono).

8.20.2. *InPort1Mux ConLst*

	Verb ID	Payload	Response
Get	F00	0E	See bitfield table.

8.20.2.1. *InPort1Mux ConLst*

Bit	Bitfield Name	RW	Reset	Description
[31.:8]	Rsvd	R	000000	Reserved.
[7]	LForm	R	0	Connection list format: 1 = long-form (15-bit) NID entries 0 = short-form (7-bit) NID entries.
[6.:0]	ConL	R	03	Number of NID entries in connection list.

8.20.3. InPort1Mux ConLstEntry0

	Verb ID	Payload	Response
Get	F02	00	See bitfield table.

8.20.3.1. InPort1Mux ConLstEntry0

Bit	Bitfield Name	RW	Reset	Description
[31..24]	ConL3	R	00	Unused list entry.
[23..16]	ConL2	R	0E	Port E Pin widget (0x0E)
[15..8]	ConL1	R	0C	Port C Pin widget (0x0C)
[7..0]	ConL0	R	0B	Port B Pin widget (0x0B)

8.20.4. InPort1Mux ConSelectCtrl

	Verb ID	Payload	Response
Get	F01	00	See bitfield table.

8.20.4.1. InPort1Mux ConSelectCtrl

Bit	Bitfield Name	RW	Reset	Description
[31..2]	Rsvd	R	00000000	Reserved.
[1..0]	Index	RW	0	Connection select control index.

8.20.5. InPort1Mux OutAmpCap

	Verb ID	Payload	Response
Get	F00	12	See bitfield table.

8.20.5.1. *InPort1Mux OutAmpCap*

Bit	Bitfield Name	RW	Reset	Description
[31]	Mute	R	0	Mute support: 1 = yes 0 = no.
[30.:23]	Rsvd3	R	00	Reserved.
[22.:16]	StepSize	R	27	Size of each step in the gain range: 0 to 127 = .25dB to 32dB in .25dB steps.
[15]	Rsvd2	R	0	Reserved.
[14.:8]	NumSteps	R	03	Number of gains steps (number of possible settings - 1).
[7]	Rsvd1	R	0	Reserved.
[6.:0]	Offset	R	00	Indicates which step is 0dB

8.20.6. *InPort1Mux OutAmpLeft*

	Verb ID	Payload	Response
Get	BA0	00	See bitfield table.

8.20.6.1. *InPort1Mux OutAmpLeft*

Bit	Bitfield Name	RW	Reset	Description
[31.:3]	Rsvd1	R	00000000	Reserved.
[2.:0]	Gain	RW	0	Amp gain step number (see OutAmp-Cap parameter pertaining to this widget).

8.20.7. InPort1Mux OutAmpRight

	Verb ID	Payload	Response
Get	B80	00	See bitfield table.

8.20.7.1. InPort1Mux OutAmpRight

Bit	Bitfield Name	RW	Reset	Description
[31..3]	Rsvd1	R	00000000	Reserved.
[2..0]	Gain	RW	0	Amp gain step number (see OutAmp-Cap parameter pertaining to this widget).

8.21. ADC0Mux Node (NID = 1C)**8.21.1. ADC0Mux WCap**

	Verb ID	Payload	Response
Get	F00	09	See bitfield table.

8.21.1.1. ADC0Mux WCap

Bit	Bitfield Name	RW	Reset	Description
[31..24]	Rsvd2	R	00	Reserved.
[23..20]	Type	R	3	Widget type: 0h = Out Converter; 1h = In Converter; 2h = Summing (Mixer); 3h = Selector (Mux); 4h = Pin Complex; 5h = Power; 6h = Volume Knob; 7h = Beep Generator; 8h-Eh = Reserved; Fh = Vendor Defined
[19..16]	Delay	R	0	Number of sample delays through widget.
[15..12]	Rsvd1	R	0	Reserved.

8.21.1.1. *ADC0Mux WCap*

Bit	Bitfield Name	RW	Reset	Description
[11]	SwapCap	R	1	Left/right swap support: 1 = yes 0 = no.
[10]	PwrCntrl	R	0	Power state support: 1 = yes 0 = no.
[9]	DigitalStrm	R	0	Digital stream support: 1 = yes (digital) 0 = no (analog).
[8]	ConnList	R	1	Connection list present: 1 = yes 0 = no.
[7]	UnsolCap	R	0	Unsolicited response support: 1 = yes 0 = no.
[6]	ProcWidget	R	0	Processing state support: 1 = yes 0 = no.
[5]	Stripe	R	0	Striping support: 1 = yes 0 = no.
[4]	FormatOvrd	R	0	Stream format override: 1 = yes 0 = no.
[3]	AmpParamOvrd	R	1	Amplifier capabilities override: 1 = yes no.
[2]	OutAmpPrsnt	R	1	Output amp present: 1 = yes 0 = no.
[1]	InAmpPrsnt	R	0	Input amp present: 1 = yes 0 = no.
[0]	Stereo	R	1	Stereo stream support: 1 = yes (stereo) 0 = no (mono).

8.21.2. *ADC0Mux ConLst*

	Verb ID	Payload	Response
Get	F00	0E	See bitfield table.

8.21.2.1. *ADC0Mux ConLst*

Bit	Bitfield Name	RW	Reset	Description
[31..8]	Rsvd	R	000000	Reserved.
[7]	LForm	R	0	Connection list format: 1 = long-form (15-bit) NID entries 0 = short-form (7-bit) NID entries.
[6..0]	ConL	R	04	Number of NID entries in connection list.

8.21.3. *ADC0Mux ConLstEntry0*

	Verb ID	Payload	Response
Get	F02	00	See bitfield table.

8.21.3.1. *ADC0Mux ConLstEntry0*

Bit	Bitfield Name	RW	Reset	Description
[31..24]	ConL3	R	19	DMic1 Pin widget (0x19)
[23..16]	ConL2	R	18	DMic0 Pin widget (0x18)
[15..8]	ConL1	R	17	InputMixer Summing widget (0x17)
[7..0]	ConL0	R	1A	InPort0Mux Selector widget (0x1A)

8.21.4. *ADC0Mux ConSelectCtrl*

	Verb ID	Payload	Response
Get	F01	00	See bitfield table.

8.21.4.1. *ADC0Mux ConSelectCtrl*

Bit	Bitfield Name	RW	Reset	Description
[31..2]	Rsvd	R	00000000	Reserved.
[1..0]	Index	RW	0	Connection select control index.

8.21.5. *ADC0Mux LR*

	Verb ID	Payload	Response
Get	F0C	00	See bitfield table.

8.21.5.1. *ADC0Mux LR*

Bit	Bitfield Name	RW	Reset	Description
[31..3]	Rsvd2	R	00000000	Reserved.
[2]	SwapEn	RW	0	Swap enable: 1 = L/R swap enabled 0 = L/R swap disabled.
[1..0]	Rsvd1	R	0	Reserved.

8.21.6. *ADC0Mux OutAmpCap*

	Verb ID	Payload	Response
Get	F00	12	See bitfield table.

8.21.6.1. ADC0Mux OutAmpCap

Bit	Bitfield Name	RW	Reset	Description
[31]	Mute	R	1	Mute support: 1 = yes 0 = no.
[30.:23]	Rsvd3	R	00	Reserved.
[22.:16]	StepSize	R	05	Size of each step in the gain range: 0 to 127 = .25dB to 32dB in .25dB steps.
[15]	Rsvd2	R	0	Reserved.
[14.:8]	NumSteps	R	0F	Number of gains steps (number of possible settings - 1).
[7]	Rsvd1	R	0	Reserved.
[6.:0]	Offset	R	00	Indicates which step is 0dB

8.21.7. ADC0Mux OutAmpLeft

	Verb ID	Payload	Response
Get	BA0	00	See bitfield table.

8.21.7.1. ADC0Mux OutAmpLeft

Bit	Bitfield Name	RW	Reset	Description
[31.:8]	Rsvd2	R	000000	Reserved.
[7]	Mute	RW	1	Amp mute: 1 = muted 0 = not muted.
[6.:4]	Rsvd1	R	0	Reserved.
[3.:0]	Gain	RW	0	Amp gain step number (see OutAmpCap parameter pertaining to this widget).

8.21.8. ADC0Mux OutAmpRight

	Verb ID	Payload	Response
Get	B80	00	See bitfield table.

8.21.8.1. ADC0Mux OutAmpRight

Bit	Bitfield Name	RW	Reset	Description
[31..8]	Rsvd2	R	000000	Reserved.
[7]	Mute	RW	1	Amp mute: 1 = muted 0 = not muted.
[6..4]	Rsvd1	R	0	Reserved.
[3..0]	Gain	RW	0	Amp gain step number (see OutAmp-Cap parameter pertaining to this widget).

8.22. ADC1Mux Node (NID = 1D)**8.22.1. ADC1Mux WCap**

	Verb ID	Payload	Response
Get	F00	09	See bitfield table.

8.22.1.1. ADC1Mux WCap

Bit	Bitfield Name	RW	Reset	Description
[31..24]	Rsvd2	R	00	Reserved.
[23..20]	Type	R	3	Widget type: 0h = Out Converter; 1h = In Converter; 2h = Summing (Mixer); 3h = Selector (Mux); 4h = Pin Complex; 5h = Power; 6h = Volume Knob; 7h = Beep Generator; 8h-Eh = Reserved; Fh = Vendor Defined

8.22.1.1. *ADC1Mux WCap*

Bit	Bitfield Name	RW	Reset	Description
[19.:16]	Delay	R	0	Number of sample delays through widget.
[15.:12]	Rsvd1	R	0	Reserved.
[11]	SwapCap	R	1	Left/right swap support: 1 = yes 0 = no.
[10]	PwrCntrl	R	0	Power state support: 1 = yes 0 = no.
[9]	DigitalStrm	R	0	Digital stream support: 1 = yes (digital) 0 = no (analog).
[8]	ConnList	R	1	Connection list present: 1 = yes 0 = no.
[7]	UnsolCap	R	0	Unsolicited response support: 1 = yes 0 = no.
[6]	ProcWidget	R	0	Processing state support: 1 = yes 0 = no.
[5]	Stripe	R	0	Striping support: 1 = yes 0 = no.
[4]	FormatOvrd	R	0	Stream format override: 1 = yes 0 = no.
[3]	AmpParamOvrd	R	1	Amplifier capabilities override: 1 = yes no.
[2]	OutAmpPrsnt	R	1	Output amp present: 1 = yes 0 = no.
[1]	InAmpPrsnt	R	0	Input amp present: 1 = yes 0 = no.
[0]	Stereo	R	1	Stereo stream support: 1 = yes (stereo) 0 = no (mono).

8.22.2. *ADC1Mux ConLst*

	Verb ID	Payload	Response
Get	F00	0E	See bitfield table.

8.22.2.1. *ADC1Mux ConLst*

Bit	Bitfield Name	RW	Reset	Description
[31..8]	Rsvd	R	000000	Reserved.
[7]	LForm	R	0	Connection list format: 1 = long-form (15-bit) NID entries 0 = short-form (7-bit) NID entries.
[6..0]	ConL	R	04	Number of NID entries in connection list.

8.22.3. *ADC1Mux ConLstEntry0*

	Verb ID	Payload	Response
Get	F02	00	See bitfield table.

8.22.3.1. *ADC1Mux ConLstEntry0*

Bit	Bitfield Name	RW	Reset	Description
[31..24]	ConL3	R	19	DMic1 Pin widget (0x19)
[23..16]	ConL2	R	18	DMic0 Pin widget (0x18)
[15..8]	ConL1	R	17	InputMixer Summing widget (0x17)
[7..0]	ConL0	R	1B	InPort1Mux Selector widget (0x1B)

8.22.4. *ADC1Mux ConSelectCtrl*

	Verb ID	Payload	Response
Get	F01	00	See bitfield table.

8.22.4.1. *ADC1Mux ConSelectCtrl*

Bit	Bitfield Name	RW	Reset	Description
[31..2]	Rsvd	R	00000000	Reserved.
[1..0]	Index	RW	0	Connection select control index.

8.22.5. *ADC1Mux LR*

	Verb ID	Payload	Response
Get	F0C	00	See bitfield table.

8.22.5.1. *ADC1Mux LR*

Bit	Bitfield Name	RW	Reset	Description
[31..3]	Rsvd2	R	00000000	Reserved.
[2]	SwapEn	RW	0	Swap enable: 1 = L/R swap enabled 0 = L/R swap disabled.
[1..0]	Rsvd1	R	0	Reserved.

8.22.6. *ADC1Mux OutAmpCap*

	Verb ID	Payload	Response
Get	F00	12	See bitfield table.

8.22.6.1. *ADC1Mux OutAmpCap*

Bit	Bitfield Name	RW	Reset	Description
[31]	Mute	R	1	Mute support: 1 = yes 0 = no.
[30.:23]	Rsvd3	R	00	Reserved.
[22.:16]	StepSize	R	05	Size of each step in the gain range: 0 to 127 = .25dB to 32dB in .25dB steps.
[15]	Rsvd2	R	0	Reserved.
[14.:8]	NumSteps	R	0F	Number of gains steps (number of possible settings - 1).
[7]	Rsvd1	R	0	Reserved.
[6.:0]	Offset	R	00	Indicates which step is 0dB

8.22.7. *ADC1Mux OutAmpLeft*

	Verb ID	Payload	Response
Get	BA0	00	See bitfield table.

8.22.7.1. *ADC1Mux OutAmpLeft*

Bit	Bitfield Name	RW	Reset	Description
[31.:8]	Rsvd2	R	000000	Reserved.
[7]	Mute	RW	1	Amp mute: 1 = muted 0 = not muted.
[6.:4]	Rsvd1	R	0	Reserved.
[3.:0]	Gain	RW	0	Amp gain step number (see OutAmpCap parameter pertaining to this widget).

8.22.8. ADC1Mux OutAmpRight

	Verb ID	Payload	Response
Get	B80	00	See bitfield table.

8.22.8.1. ADC1Mux OutAmpRight

Bit	Bitfield Name	RW	Reset	Description
[31..8]	Rsvd2	R	000000	Reserved.
[7]	Mute	RW	1	Amp mute: 1 = muted 0 = not muted.
[6..4]	Rsvd1	R	0	Reserved.
[3..0]	Gain	RW	0	Amp gain step number (see OutAmp-Cap parameter pertaining to this widget).

8.23. Dig0Pin Node (NID = 1E)**8.23.1. Dig0Pin WCap**

	Verb ID	Payload	Response
Get	F00	09	See bitfield table.

8.23.1.1. Dig0Pin WCap

Bit	Bitfield Name	RW	Reset	Description
[31..24]	Rsvd2	R	00	Reserved.
[23..20]	Type	R	4	Widget type: 0h = Out Converter; 1h = In Converter; 2h = Summing (Mixer); 3h = Selector (Mux); 4h = Pin Complex; 5h = Power; 6h = Volume Knob; 7h = Beep Generator; 8h-Eh = Reserved; Fh = Vendor Defined

8.23.1.1. *Dig0Pin WCap*

Bit	Bitfield Name	RW	Reset	Description
[19.:16]	Delay	R	0	Number of sample delays through widget.
[15.:12]	Rsvd1	R	0	Reserved.
[11]	SwapCap	R	0	Left/right swap support: 1 = yes 0 = no.
[10]	PwrCntrl	R	0	Power state support: 1 = yes 0 = no.
[9]	Dig	R	1	Digital stream support: 1 = yes (digital) 0 = no (analog).
[8]	ConnList	R	1	Connection list present: 1 = yes 0 = no.
[7]	UnSolCap	R	0	Unsolicited response support: 1 = yes 0 = no.
[6]	ProcWidget	R	0	Processing state support: 1 = yes 0 = no.
[5]	Stripe	R	0	Striping support: 1 = yes 0 = no.
[4]	FormatOvrd	R	0	Stream format override: 1 = yes 0 = no.
[3]	AmpParOvrd	R	0	Amplifier capabilities override: 1 = yes no.
[2]	OutAmpPrsnt	R	0	Output amp present: 1 = yes 0 = no.
[1]	InAmpPrsnt	R	0	Input amp present: 1 = yes 0 = no.
[0]	Stereo	R	1	Stereo stream support: 1 = yes (stereo) 0 = no (mono).

8.23.2. *Dig0Pin PinCap*

	Verb ID	Payload	Response
Get	F00	0C	See bitfield table.

8.23.2.1. *Dig0Pin PinCap*

Bit	Bitfield Name	RW	Reset	Description
[31.:17]	Rsvd2	R	0000	Reserved.
[16]	EapdCap	R	0	EAPD support: 1 = yes 0 = no.
[15.:8]	VrefCntrl	R	00	Vref support: bit 7 = Reserved; bit 6 = Reserved; bit 5 = 100% support (1 = yes 0 = no); bit 4 = 80% support (1 = yes 0 = no); bit 3 = Reserved; bit 2 = GND support (1 = yes 0 = no); bit 1 = 50% support (1 = yes 0 = no); bit 0 = Hi-Z support (1 = yes 0 = no)
[7]	Rsvd1	R	0	Reserved.
[6]	BalancedIO	R	0	Balanced I/O support: 1 = yes 0 = no.
[5]	InCap	R	0	Input support: 1 = yes 0 = no.
[4]	OutCap	R	1	Output support: 1 = yes 0 = no.
[3]	HdphDrvCap	R	0	Headphone amp present: 1 = yes 0 = no.
[2]	PresDtctCap	R	0	Presence detection support: 1 = yes 0 = no.
[1]	TrigRqd	R	0	Trigger required for impedance sense: 1 = yes 0 = no.
[0]	ImpSenseCap	R	0	Impedance sense support: 1 = yes 0 = no.

8.23.3. *Dig0Pin ConLst*

	Verb ID	Payload	Response
Get	F00	0E	See bitfield table.

8.23.3.1. *Dig0Pin ConLst*

Bit	Bitfield Name	RW	Reset	Description
[31..8]	Rsvd	R	000000	Reserved.
[7]	LForm	R	0	Connection list format: 1 = long-form (15-bit) NID entries 0 = short-form (7-bit) NID entries.
[6..0]	ConL	R	01	Number of NID entries in connection list.

8.23.4. *Dig0Pin ConLstEntry0*

	Verb ID	Payload	Response
Get	F02	00	See bitfield table.

8.23.4.1. *Dig0Pin ConLstEntry0*

Bit	Bitfield Name	RW	Reset	Description
[31..24]	ConL3	R	00	Unused list entry.
[23..16]	ConL2	R	00	Unused list entry.
[15..8]	ConL1	R	00	Unused list entry.
[7..0]	ConL0	R	24	Dig0Mux Selector widget (0x24)

8.23.5. *Dig0Pin PinWCntrl*

	Verb ID	Payload	Response
Get	F07	00	See bitfield table.

8.23.5.1. *Dig0Pin PinWCntrl*

Bit	Bitfield Name	RW	Reset	Description
[31..7]	Rsvd2	R	0000000	Reserved.
[6]	OutEn	RW	0	Output enable: 1 = enabled 0 = disabled.
[5..0]	Rsvd1	R	00	Reserved.

8.23.6. *Dig0Pin ConfigDefault*

	Verb ID	Payload	Response
Get	F1C	00	See bitfield table.

8.23.6.1. *Dig0Pin ConfigDefault*

Bit	Bitfield Name	RW	Reset	Description
[31..30]	PortConnectivity	RW	0	Port connectivity: 0h = Port complex is connected to a jack; 1h = No physical connection for port; 2h = Fixed function device is attached; 3h = Both jack and internal device attached (info in all other fields refers to integrated device any presence detection refers to jack)
[29..24]	Location	RW	1	Location. Bits [5..4]: 0h = External on primary chassis; 1h = Internal; 2h = Separate chassis; 3h = Other. Bits [3..0]: 0h = N/A; 1h = Rear; 2h = Front; 3h = Left; 4h = Right; 5h = Top; 6h = Bottom; 7h-9h = Special; Ah-Fh = Reserved

8.23.6.1. *Dig0Pin ConfigDefault*

Bit	Bitfield Name	RW	Reset	Description
[23.:20]	Device	RW	4	Default device: 0h = Line out; 1h = Speaker; 2h = HP out; 3h = CD; 4h = SPDIF Out; 5h = Digital other out; 6h = Modem line side; 7h = Modem handset side; 8h = Line in; 9h = Aux; Ah = Mic in; Bh = Telephony; Ch = SPDIF In; Dh = Digital other in; Eh = Reserved; Fh = Other
[19.:16]	ConnectionType	RW	5	Connection type: 0h = Unknown; 1h = 1/8" stereo/mono; 2h = 1/4" stereo/mono; 3h = ATAPI internal; 4h = RCA; 5h = Optical; 6h = Other digital; 7h = Other analog; 8h = Multichannel analog (DIN); 9h = XLR/Professional; Ah = RJ-11 (modem); Bh = Combination; Ch-Eh = Reserved; Fh = Other
[15.:12]	Color	RW	2	Color: 0h = Unknown; 1h = Black; 2h = Grey; 3h = Blue; 4h = Green; 5h = Red; 6h = Orange; 7h = Yellow; 8h = Purple; 9h = Pink; Ah-Dh = Reserved; Eh = White; Fh = Other
[11.:8]	Misc	RW	0	Miscellaneous: Bits [3..1] = Reserved; Bit 0 = Jack detect override
[7.:4]	Association	RW	5	Default association.
[3.:0]	Sequence	RW	0	Sequence.

8.24. **Dig1Pin Node (NID = 1F)**8.24.1. *Dig1Pin WCap*

	Verb ID	Payload	Response
Get	F00	09	See bitfield table.

8.24.1.1. *Dig1Pin WCap*

Bit	Bitfield Name	RW	Reset	Description
[31.:24]	Rsvd2	R	00	Reserved.
[23.:20]	Type	R	4	Widget type: 0h = Out Converter; 1h = In Converter; 2h = Summing (Mixer); 3h = Selector (Mux); 4h = Pin Complex; 5h = Power; 6h = Volume Knob; 7h = Beep Generator; 8h-Eh = Reserved; Fh = Vendor Defined
[19.:16]	Delay	R	0	Number of sample delays through widget.
[15.:12]	Rsvd1	R	0	Reserved.
[11]	SwapCap	R	0	Left/right swap support: 1 = yes 0 = no.
[10]	PwrCntrl	R	1	Power state support: 1 = yes 0 = no.
[9]	Dig	R	1	Digital stream support: 1 = yes (digital) 0 = no (analog).
[8]	ConnList	R	1	Connection list present: 1 = yes 0 = no.
[7]	UnSolCap	R	0	Unsolicited response support: 1 = yes 0 = no.
[6]	ProcWidget	R	0	Processing state support: 1 = yes 0 = no.
[5]	Stripe	R	0	Striping support: 1 = yes 0 = no.
[4]	FormatOvrd	R	0	Stream format override: 1 = yes 0 = no.
[3]	AmpParOvrd	R	0	Amplifier capabilities override: 1 = yes no.
[2]	OutAmpPrsnt	R	0	Output amp present: 1 = yes 0 = no.
[1]	InAmpPrsnt	R	0	Input amp present: 1 = yes 0 = no.
[0]	Stereo	R	1	Stereo stream support: 1 = yes (stereo) 0 = no (mono).

8.24.2. Dig1Pin PinCap

	Verb ID	Payload	Response
Get	F00	0C	See bitfield table.

8.24.2.1. Dig1Pin PinCap

Bit	Bitfield Name	RW	Reset	Description
[31.:17]	Rsvd2	R	0000	Reserved.
[16]	EapdCap	R	1	EAPD support: 1 = yes 0 = no.
[15.:8]	VrefCntrl	R	00	Vref support: bit 7 = Reserved; bit 6 = Reserved; bit 5 = 100% support (1 = yes 0 = no); bit 4 = 80% support (1 = yes 0 = no); bit 3 = Reserved; bit 2 = GND support (1 = yes 0 = no); bit 1 = 50% support (1 = yes 0 = no); bit 0 = Hi-Z support (1 = yes 0 = no)
[7]	Rsvd1	R	0	Reserved.
[6]	BalancedIO	R	0	Balanced I/O support: 1 = yes 0 = no.
[5]	InCap	R	0	Input support: 1 = yes 0 = no.
[4]	OutCap	R	1	Output support: 1 = yes 0 = no.
[3]	HdphDrvCap	R	0	Headphone amp present: 1 = yes 0 = no.
[2]	PresDtctCap	R	0	Presence detection support: 1 = yes 0 = no.
[1]	TrigRqd	R	0	Trigger required for impedance sense: 1 = yes 0 = no.
[0]	ImpSenseCap	R	0	Impedance sense support: 1 = yes 0 = no.

8.24.3. Dig1Pin ConLst

	Verb ID	Payload	Response
Get	F00	0E	See bitfield table.

8.24.3.1. Dig1Pin ConLst

Bit	Bitfield Name	RW	Reset	Description
[31..8]	Rsvd	R	000000	Reserved.
[7]	LForm	R	0	Connection list format: 1 = long-form (15-bit) NID entries 0 = short-form (7-bit) NID entries.
[6..0]	ConL	R	02	Number of NID entries in connection list.

8.24.4. Dig1Pin ConLstEntry0

	Verb ID	Payload	Response
Get	F02	00	See bitfield table.

8.24.4.1. Dig1Pin ConLstEntry0

Bit	Bitfield Name	RW	Reset	Description
[31..24]	ConL3	R	00	Unused list entry.
[23..16]	ConL2	R	00	Unused list entry.
[15..8]	ConL1	R	25	Dig2Mux Selector widget (0x25)
[7..0]	ConL0	R	24	Dig0Mux Selector widget (0x24)

8.24.5. Dig1Pin ConSelectCtrl

	Verb ID	Payload	Response
Get	F01	00	See bitfield table.

8.24.5.1. Dig1Pin ConSelectCtrl

Bit	Bitfield Name	RW	Reset	Description
[31.:1]	Rsvd	R	00000000	Reserved.
[0]	Index	RW	0	Connection select control index.

8.24.6. Dig1Pin PinWCntrl

	Verb ID	Payload	Response
Get	F07	00	See bitfield table.

8.24.6.1. Dig1Pin PinWCntrl

Bit	Bitfield Name	RW	Reset	Description
[31.:7]	Rsvd2	R	00000000	Reserved.
[6]	OutEn	RW	0	Output enable: 1 = enabled 0 = disabled.
[5.:0]	Rsvd1	R	00	Reserved.

8.24.7. Dig1Pin PwrState

	Verb ID	Payload	Response
Get	F05	00	See bitfield table.

8.24.7.1. *Dig1Pin PwrState*

Bit	Bitfield Name	RW	Reset	Description
[31.:6]	Rsvd2	R	0000000	Reserved.
[5.:4]	Act	R	3	Actual power state of this widget.
[3.:2]	Rsvd1	R	0	Reserved.
[1.:0]	Set	RW	3	Current power state setting for this widget used for EAPD control in this case: 0h-1h = Pin drives the value of the EAPD control bit; 2h-3h = Pin tri-stated

8.24.8. *Dig1Pin EAPD*

	Verb ID	Payload	Response
Get	F0C	00	See bitfield table.

8.24.8.1. *Dig1Pin EAPD*

Bit	Bitfield Name	RW	Reset	Description
[31.:2]	Rsvd2	R	00000000	Reserved.
[1]	Control	RW	0	EAPD value reflected on the EAPD pin: 0 = Power down external amplifier; 1 = Power up external amplifier
[0]	Rsvd1	R	0	Reserved.

8.24.9. *Dig1Pin ConfigDefault*

	Verb ID	Payload	Response
Get	F1C	00	See bitfield table.

8.24.9.1. *Dig1Pin ConfigDefault*

Bit	Bitfield Name	RW	Reset	Description
[31..30]	PortConnectivity	RW	2	Port connectivity: 0h = Port complex is connected to a jack; 1h = No physical connection for port; 2h = Fixed function device is attached; 3h = Both jack and internal device attached (info in all other fields refers to integrated device any presence detection refers to jack)
[29..24]	Location	RW	18	Location. Bits [5..4]: 0h = External on primary chassis; 1h = Internal; 2h = Separate chassis; 3h = Other. Bits [3..0]: 0h = N/A; 1h = Rear; 2h = Front; 3h = Left; 4h = Right; 5h = Top; 6h = Bottom; 7h-9h = Special; Ah-Fh = Reserved
[23..20]	Device	RW	5	Default device: 0h = Line out; 1h = Speaker; 2h = HP out; 3h = CD; 4h = SPDIF Out; 5h = Digital other out; 6h = Modem line side; 7h = Modem handset side; 8h = Line in; 9h = Aux; Ah = Mic in; Bh = Telephony; Ch = SPDIF In; Dh = Digital other in; Eh = Reserved; Fh = Other
[19..16]	ConnectionType	RW	6	Connection type: 0h = Unknown; 1h = 1/8" stereo/mono; 2h = 1/4" stereo/mono; 3h = ATAPI internal; 4h = RCA; 5h = Optical; 6h = Other digital; 7h = Other analog; 8h = Multichannel analog (DIN); 9h = XLR/Professional; Ah = RJ-11 (modem); Bh = Combination; Ch-Eh = Reserved; Fh = Other
[15..12]	Color	RW	0	Color: 0h = Unknown; 1h = Black; 2h = Grey; 3h = Blue; 4h = Green; 5h = Red; 6h = Orange; 7h = Yellow; 8h = Purple; 9h = Pink; Ah-Dh = Reserved; Eh = White; Fh = Other
[11..8]	Misc	RW	0	Miscellaneous: Bits [3..1] = Reserved; Bit 0 = Jack detect override
[7..4]	Association	RW	6	Default association.
[3..0]	Sequence	RW	0	Sequence.

8.25. Dig2Pin Node (NID = 20)

8.25.1. Dig2Pin WCap

	Verb ID	Payload	Response
Get	F00	09	See bitfield table.

8.25.1.1. Dig2Pin WCap

Bit	Bitfield Name	RW	Reset	Description
[31..24]	Rsvd2	R	00	Reserved.
[23..20]	Type	R	4	Widget type: 0h = Out Converter; 1h = In Converter; 2h = Summing (Mixer); 3h = Selector (Mux); 4h = Pin Complex; 5h = Power; 6h = Volume Knob; 7h = Beep Generator; 8h-Eh = Reserved; Fh = Vendor Defined
[19..16]	Delay	R	0	Number of sample delays through widget.
[15..12]	Rsvd1	R	0	Reserved.
[11]	SwapCap	R	0	Left/right swap support: 1 = yes 0 = no.
[10]	PwrCntrl	R	0	Power state support: 1 = yes 0 = no.
[9]	Dig	R	1	Digital stream support: 1 = yes (digital) 0 = no (analog).
[8]	ConnList	R	1	Connection list present: 1 = yes 0 = no.
[7]	UnSolCap	R	0	Unsolicited response support: 1 = yes 0 = no.
[6]	ProcWidget	R	0	Processing state support: 1 = yes 0 = no.
[5]	Stripe	R	0	Striping support: 1 = yes 0 = no.
[4]	FormatOvrd	R	0	Stream format override: 1 = yes 0 = no.
[3]	AmpParOvrd	R	0	Amplifier capabilities override: 1 = yes no.
[2]	OutAmpPrsnt	R	0	Output amp present: 1 = yes 0 = no.

8.25.1.1. *Dig2Pin WCap*

Bit	Bitfield Name	RW	Reset	Description
[1]	InAmpPrsnt	R	0	Input amp present: 1 = yes 0 = no.
[0]	Stereo	R	1	Stereo stream support: 1 = yes (stereo) 0 = no (mono).

8.25.2. *Dig2Pin PinCap*

	Verb ID	Payload	Response
Get	F00	0C	See bitfield table.

8.25.2.1. *Dig2Pin PinCap*

Bit	Bitfield Name	RW	Reset	Description
[31.:17]	Rsvd2	R	0000	Reserved.
[16]	EapdCap	R	0	EAPD support: 1 = yes 0 = no.
[15.:8]	VrefCntrl	R	00	Vref support: bit 7 = Reserved; bit 6 = Reserved; bit 5 = 100% support (1 = yes 0 = no); bit 4 = 80% support (1 = yes 0 = no); bit 3 = Reserved; bit 2 = GND support (1 = yes 0 = no); bit 1 = 50% support (1 = yes 0 = no); bit 0 = Hi-Z support (1 = yes 0 = no)
[7]	Rsvd1	R	0	Reserved.
[6]	BalancedIO	R	0	Balanced I/O support: 1 = yes 0 = no.
[5]	InCap	R	0	Input support: 1 = yes 0 = no.
[4]	OutCap	R	1	Output support: 1 = yes 0 = no.
[3]	HdphDrvCap	R	0	Headphone amp present: 1 = yes 0 = no.
[2]	PresDtctCap	R	0	Presence detection support: 1 = yes 0 = no.

8.25.2.1. *Dig2Pin PinCap*

Bit	Bitfield Name	RW	Reset	Description
[1]	TrigRqd	R	0	Trigger required for impedance sense: 1 = yes 0 = no.
[0]	ImpSenseCap	R	0	Impedance sense support: 1 = yes 0 = no.

8.25.3. *Dig2Pin ConLst*

	Verb ID	Payload	Response
Get	F00	0E	See bitfield table.

8.25.3.1. *Dig2Pin ConLst*

Bit	Bitfield Name	RW	Reset	Description
[31..8]	Rsvd	R	000000	Reserved.
[7]	LForm	R	0	Connection list format: 1 = long-form (15-bit) NID entries 0 = short-form (7-bit) NID entries.
[6..0]	ConL	R	01	Number of NID entries in connection list.

8.25.4. *Dig2Pin ConLstEntry0*

	Verb ID	Payload	Response
Get	F02	00	See bitfield table.

8.25.4.1. *Dig2Pin ConLstEntry0*

Bit	Bitfield Name	RW	Reset	Description
[31.:24]	ConL3	R	00	Unused list entry.
[23.:16]	ConL2	R	00	Unused list entry.
[15.:8]	ConL1	R	00	Unused list entry.
[7.:0]	ConL0	R	25	Dig2Mux Selector widget (0x25)

8.25.5. *Dig2Pin PinWCntrl*

	Verb ID	Payload	Response
Get	F07	00	See bitfield table.

8.25.5.1. *Dig2Pin PinWCntrl*

Bit	Bitfield Name	RW	Reset	Description
[31.:7]	Rsvd2	R	0000000	Reserved.
[6]	OutEn	RW	0	Output enable: 1 = enabled 0 = disabled.
[5.:0]	Rsvd1	R	00	Reserved.

8.25.6. *Dig2Pin ConfigDefault*

	Verb ID	Payload	Response
Get	F1C	00	See bitfield table.

8.25.6.1. *Dig2Pin ConfigDefault*

Bit	Bitfield Name	RW	Reset	Description
[31..30]	PortConnectivity	RW	1	Port connectivity: 0h = Port complex is connected to a jack; 1h = No physical connection for port; 2h = Fixed function device is attached; 3h = Both jack and internal device attached (info in all other fields refers to integrated device any presence detection refers to jack)
[29..24]	Location	RW	00	Location. Bits [5..4]: 0h = External on primary chassis; 1h = Internal; 2h = Separate chassis; 3h = Other. Bits [3..0]: 0h = N/A; 1h = Rear; 2h = Front; 3h = Left; 4h = Right; 5h = Top; 6h = Bottom; 7h-9h = Special; Ah-Fh = Reserved
[23..20]	Device	RW	F	Default device: 0h = Line out; 1h = Speaker; 2h = HP out; 3h = CD; 4h = SPDIF Out; 5h = Digital other out; 6h = Modem line side; 7h = Modem handset side; 8h = Line in; 9h = Aux; Ah = Mic in; Bh = Telephony; Ch = SPDIF In; Dh = Digital other in; Eh = Reserved; Fh = Other
[19..16]	ConnectionType	RW	0	Connection type: 0h = Unknown; 1h = 1/8" stereo/mono; 2h = 1/4" stereo/mono; 3h = ATAPI internal; 4h = RCA; 5h = Optical; 6h = Other digital; 7h = Other analog; 8h = Multichannel analog (DIN); 9h = XLR/Professional; Ah = RJ-11 (modem); Bh = Combination; Ch-Eh = Reserved; Fh = Other
[15..12]	Color	RW	0	Color: 0h = Unknown; 1h = Black; 2h = Grey; 3h = Blue; 4h = Green; 5h = Red; 6h = Orange; 7h = Yellow; 8h = Purple; 9h = Pink; Ah-Dh = Reserved; Eh = White; Fh = Other
[11..8]	Misc	RW	0	Miscellaneous: Bits [3..1] = Reserved; Bit 0 = Jack detect override
[7..4]	Association	RW	F	Default association.
[3..0]	Sequence	RW	0	Sequence.

8.26. SPDIFOut0 Node (NID = 21)

8.26.1. SPDIFOut0 WCap

	Verb ID	Payload	Response
Get	F00	09	See bitfield table.

8.26.1.1. SPDIFOut0 WCap

Bit	Bitfield Name	RW	Reset	Description
[31..24]	Rsvd2	R	00	Reserved.
[23..20]	Type	R	0	Widget type: 0h = Out Converter; 1h = In Converter; 2h = Summing (Mixer); 3h = Selector (Mux); 4h = Pin Complex; 5h = Power; 6h = Volume Knob; 7h = Beep Generator; 8h-Eh = Reserved; Fh = Vendor Defined
[19..16]	Delay	R	4	Number of sample delays through widget.
[15..12]	Rsvd1	R	0	Reserved.
[11]	SwapCap	R	0	Left/right swap support: 1 = yes 0 = no.
[10]	PwrCntrl	R	0	Power state support: 1 = yes 0 = no.
[9]	Dig	R	1	Digital stream support: 1 = yes (digital) 0 = no (analog).
[8]	ConnList	R	0	Connection list present: 1 = yes 0 = no.
[7]	UnSolCap	R	0	Unsolicited response support: 1 = yes 0 = no.
[6]	ProcWidget	R	0	Processing state support: 1 = yes 0 = no.
[5]	Stripe	R	0	Striping support: 1 = yes 0 = no.
[4]	FormatOvrd	R	1	Stream format override: 1 = yes 0 = no.
[3]	AmpParOvrd	R	0	Amplifier capabilities override: 1 = yes no.
[2]	OutAmpPrsnt	R	0	Output amp present: 1 = yes 0 = no.

8.26.1.1. *SPDIFOut0 WCap*

Bit	Bitfield Name	RW	Reset	Description
[1]	InAmpPrsnt	R	0	Input amp present: 1 = yes 0 = no.
[0]	Stereo	R	1	Stereo stream support: 1 = yes (stereo) 0 = no (mono).

8.26.2. *SPDIFOut0 PCMCap*

	Verb ID	Payload	Response
Get	F00	0A	See bitfield table.

8.26.2.1. *SPDIFOut0 PCMCap*

Bit	Bitfield Name	RW	Reset	Description
[31.:21]	Rsvd2	R	000	Reserved.
[20]	B32	R	0	32 bit audio format support: 1 = yes, 0 = no.
[19]	B24	R	1	24 bit audio format support: 1 = yes, 0 = no.
[18]	B20	R	1	20 bit audio format support: 1 = yes, 0 = no.
[17]	B16	R	1	16 bit audio format support: 1 = yes, 0 = no.
[16]	B8	R	0	8 bit audio format support: 1 = yes, 0 = no.
[15.:12]	Rsvd1	R	0	Reserved.
[11]	R12	R	0	384kHz rate support: 1 = yes, 0 = no.
[10]	R11	R	1	192kHz rate support: 1 = yes, 0 = no.
[9]	R10	R	1	176.4kHz rate support: 1 = yes, 0 = no.
[8]	R9	R	1	96kHz rate support: 1 = yes, 0 = no.
[7]	R8	R	1	88.2kHz rate support: 1 = yes, 0 = no.

8.26.2.1. *SPDIFOut0 PCMCap*

Bit	Bitfield Name	RW	Reset	Description
[6]	R7	R	1	48kHz rate support: 1 = yes, 0 = no.
[5]	R6	R	1	44.1kHz rate support: 1 = yes, 0 = no.
[4]	R5	R	0	32kHz rate support: 1 = yes, 0 = no.
[3]	R4	R	0	22.05kHz rate support: 1 = yes, 0 = no.
[2]	R3	R	0	16kHz rate support: 1 = yes, 0 = no.
[1]	R2	R	0	11.025kHz rate support: 1 = yes, 0 = no.
[0]	R1	R	0	8kHz rate support: 1 = yes, 0 = no.

8.26.3. *SPDIFOut0 StreamCap*

	Verb ID	Payload	Response
Get	F00	0B	See bitfield table.

8.26.3.1. *SPDIFOut0 StreamCap*

Bit	Bitfield Name	RW	Reset	Description
[31..3]	Rsvd	R	00000000	Reserved.
[2]	AC3	R	1	AC-3 formatted data support: 1 = yes, 0 = no.
[1]	Float32	R	0	Float32 formatted data support: 1 = yes, 0 = no.
[0]	PCM	R	1	PCM-formatted data support: 1 = yes, 0 = no.

8.26.4. SPDIFOut0 Cnvtr

	Verb ID	Payload	Response
Get	A	0000	See bitfield table.

8.26.4.1. SPDIFOut0 Cnvtr

Bit	Bitfield Name	RW	Reset	Description
[31.:16]	Rsvd2	R	0000	Reserved.
[15]	FrmtNonPCM	RW	0	Stream type: 1 = Non-PCM, 0 = PCM.
[14]	FrmtSmplRate	RW	0	Sample base rate: 1 = 44.1kHz, 0 = 48kHz.
[13.:11]	SmplRateMultp	RW	0	Sample base rate multiple: 000b= x1 (48kHz/44.1kHz or less); 001b= x2 (96kHz/88.2kHz/32kHz); 010b= x3 (144kHz); 011b= x4 (192kHz/176.4kHz); 100b-111b Reserved
[10.:8]	SmplRateDiv	RW	0	Sample base rate divider: 000b= Divide by 1 (48kHz/44.1kHz); 001b= Divide by 2 (24kHz/20.05kHz); 010b= Divide by 3 (16kHz/32kHz); 011b= Divide by 4 (11.025kHz); 100b= Divide by 5 (9.6kHz); 101b= Divide by 6 (8kHz); 110b= Divide by 7; 111b= Divide by 8 (6kHz)
[7]	Rsvd1	R	0	Reserved.
[6.:4]	BitsPerSmpl	RW	3	Bits per sample: 000b= 8 bits; 001b= 16 bits; 010b= 20 bits; 011b= 24 bits; 100b= 32 bits; 101b-111b= Reserved
[3.:0]	NmbrChan	RW	1	Total number of channels in the stream assigned to this converter: 0000b-1111b= 1-16 channels.

8.26.5. SPDIFOut0 CnvtrID

	Verb ID	Payload	Response
Get	F06	00	See bitfield table.

8.26.5.1. SPDIFOut0 CnvtrID

Bit	Bitfield Name	RW	Reset	Description
[31..8]	Rsvd	R	000000	Reserved.
[7..4]	Strm	RW	0	Stream ID: 0h = Converter "off", 1h-Fh = valid IDs.
[3..0]	Ch	RW	0	Channel assignment ("Ch" and "Ch+1" assigned as a pair, for a stereo converter).

8.26.6. SPDIFOut0 DigCnvtr

	Verb ID	Payload	Response
Get	F0D	00	See bitfield table.

8.26.6.1. SPDIFOut0 DigCnvtr

Bit	Bitfield Name	RW	Reset	Description
[31..16]	Rsvd2	R	0000	Reserved.
[15]	Rsvd1	R	0	Reserved.
[14..8]	CC	RW	00	CC: Category Code.
[7]	L	RW	0	L: Generation Level.
[6]	PRO	RW	0	PRO: Professional.
[5]	AUDIO	RW	0	/AUDIO: Non-Audio.
[4]	COPY	RW	0	COPY: Copyright.

8.26.6.1. SPDIFOut0 DigCnvtr

Bit	Bitfield Name	RW	Reset	Description
[3]	PRE	RW	0	PRE: Preemphasis.
[2]	VCFG	RW	0	VCFG: Validity Config.
[1]	V	RW	0	V: Validity.
[0]	DigEn	RW	0	Digital enable: 1 = converter enabled, 0 = converter disable.

8.27. SPDIFOut1 Node (NID = 22)

8.27.1. SPDIFOut1 WCap

	Verb ID	Payload	Response
Get	F00	09	See bitfield table.

8.27.1.1. SPDIFOut1 WCap

Bit	Bitfield Name	RW	Reset	Description
[31.:24]	Rsvd2	R	00	Reserved.
[23.:20]	Type	R	0	Widget type: 0h = Out Converter; 1h = In Converter; 2h = Summing (Mixer); 3h = Selector (Mux); 4h = Pin Complex; 5h = Power; 6h = Volume Knob; 7h = Beep Generator; 8h-Eh = Reserved; Fh = Vendor Defined
[19.:16]	Delay	R	4	Number of sample delays through widget.
[15.:12]	Rsvd1	R	0	Reserved.
[11]	SwapCap	R	0	Left/right swap support: 1 = yes, 0 = no.
[10]	PwrCntrl	R	0	Power state support: 1 = yes, 0 = no.
[9]	Dig	R	1	Digital stream support: 1 = yes (digital), 0 = no (analog).
[8]	ConnList	R	0	Connection list present: 1 = yes, 0 = no.

8.27.1.1. SPDIFOut1 WCap

Bit	Bitfield Name	RW	Reset	Description
[7]	UnSolCap	R	0	Unsolicited response support: 1 = yes, 0 = no.
[6]	ProcWidget	R	0	Processing state support: 1 = yes, 0 = no.
[5]	Stripe	R	0	Striping support: 1 = yes, 0 = no.
[4]	FormatOvrd	R	1	Stream format override: 1 = yes, 0 = no.
[3]	AmpParOvrd	R	0	Amplifier capabilities override: 1 = yes, no.
[2]	OutAmpPrsnt	R	0	Output amp present: 1 = yes, 0 = no.
[1]	InAmpPrsnt	R	0	Input amp present: 1 = yes, 0 = no.
[0]	Stereo	R	1	Stereo stream support: 1 = yes (stereo), 0 = no (mono).

8.27.2. SPDIFOut1 PCMCap

	Verb ID	Payload	Response
Get	F00	0A	See bitfield table.

8.27.2.1. SPDIFOut1 PCMCap

Bit	Bitfield Name	RW	Reset	Description
[31.:21]	Rsvd2	R	000	Reserved.
[20]	B32	R	0	32 bit audio format support: 1 = yes, 0 = no.
[19]	B24	R	1	24 bit audio format support: 1 = yes, 0 = no.
[18]	B20	R	1	20 bit audio format support: 1 = yes, 0 = no.
[17]	B16	R	1	16 bit audio format support: 1 = yes, 0 = no.

8.27.2.1. SPDIFOut1 PCMCap

Bit	Bitfield Name	RW	Reset	Description
[16]	B8	R	0	8 bit audio format support: 1 = yes, 0 = no.
[15..12]	Rsvd1	R	0	Reserved.
[11]	R12	R	0	384kHz rate support: 1 = yes, 0 = no.
[10]	R11	R	1	192kHz rate support: 1 = yes, 0 = no.
[9]	R10	R	1	176.4kHz rate support: 1 = yes, 0 = no.
[8]	R9	R	1	96kHz rate support: 1 = yes, 0 = no.
[7]	R8	R	1	88.2kHz rate support: 1 = yes, 0 = no.
[6]	R7	R	1	48kHz rate support: 1 = yes, 0 = no.
[5]	R6	R	1	44.1kHz rate support: 1 = yes, 0 = no.
[4]	R5	R	0	32kHz rate support: 1 = yes, 0 = no.
[3]	R4	R	0	22.05kHz rate support: 1 = yes, 0 = no.
[2]	R3	R	0	16kHz rate support: 1 = yes, 0 = no.
[1]	R2	R	0	11.025kHz rate support: 1 = yes, 0 = no.
[0]	R1	R	0	8kHz rate support: 1 = yes, 0 = no.

8.27.3. SPDIFOut1 StreamCap

	Verb ID	Payload	Response
Get	F00	0B	See bitfield table.

8.27.3.1. SPDIFOut1 StreamCap

Bit	Bitfield Name	RW	Reset	Description
[31..3]	Rsvd	R	00000000	Reserved.
[2]	AC3	R	1	AC-3 formatted data support: 1 = yes, 0 = no.

8.27.3.1. *SPDIFOut1 StreamCap*

Bit	Bitfield Name	RW	Reset	Description
[1]	Float32	R	0	Float32 formatted data support: 1 = yes, 0 = no.
[0]	PCM	R	1	PCM-formatted data support: 1 = yes, 0 = no.

8.27.4. *SPDIFOut1 Cnvtr*

	Verb ID	Payload	Response
Get	A	0000	See bitfield table.

8.27.4.1. *SPDIFOut1 Cnvtr*

Bit	Bitfield Name	RW	Reset	Description
[31.:16]	Rsvd2	R	0000	Reserved.
[15]	FrmtNonPCM	RW	0	Stream type: 1 = Non-PCM, 0 = PCM.
[14]	FrmtSmplRate	RW	0	Sample base rate: 1 = 44.1kHz, 0 = 48kHz.
[13.:11]	SmplRateMultp	RW	0	Sample base rate multiple: 000b= x1 (48kHz/44.1kHz or less); 001b= x2 (96kHz/88.2kHz/32kHz); 010b= x3 (144kHz); 011b= x4 (192kHz/176.4kHz); 100b-111b Reserved
[10.:8]	SmplRateDiv	RW	0	Sample base rate divider: 000b= Divide by 1 (48kHz/44.1kHz); 001b= Divide by 2 (24kHz/20.05kHz); 010b= Divide by 3 (16kHz/32kHz); 011b= Divide by 4 (11.025kHz); 100b= Divide by 5 (9.6kHz); 101b= Divide by 6 (8kHz); 110b= Divide by 7; 111b= Divide by 8 (6kHz)
[7]	Rsvd1	R	0	Reserved.

8.27.4.1. *SPDIFOut1 Cnvtr*

Bit	Bitfield Name	RW	Reset	Description
[6.:4]	BitsPerSmpl	RW	3	Bits per sample: 000b= 8 bits; 001b= 16 bits; 010b= 20 bits; 011b= 24 bits; 100b= 32 bits; 101b-111b= Reserved
[3.:0]	NmbrChan	RW	1	Total number of channels in the stream assigned to this converter: 0000b-1111b= 1-16 channels.

8.27.5. *SPDIFOut1 CnvtrID*

	Verb ID	Payload	Response
Get	F06	00	See bitfield table.

8.27.5.1. *SPDIFOut1 CnvtrID*

Bit	Bitfield Name	RW	Reset	Description
[31.:8]	Rsvd	R	000000	Reserved.
[7.:4]	Strm	RW	0	Stream ID: 0h = Converter "off", 1h-Fh = valid IDs.
[3.:0]	Ch	RW	0	Channel assignment ("Ch" and "Ch+1" assigned as a pair, for a stereo converter).

8.27.6. *SPDIFOut1 DigCnvtr*

	Verb ID	Payload	Response
Get	F0D	00	See bitfield table.

8.27.6.1. *SPDIFOut1 DigCnvtr*

Bit	Bitfield Name	RW	Reset	Description
[31.:16]	Rsvd2	R	0000	Reserved.
[15]	Rsvd1	R	0	Reserved.
[14.:8]	CC	RW	00	CC: Category Code.
[7]	L	RW	0	L: Generation Level.
[6]	PRO	RW	0	PRO: Professional.
[5]	AUDIO	RW	0	/AUDIO: Non-Audio.
[4]	COPY	RW	0	COPY: Copyright.
[3]	PRE	RW	0	PRE: Preemphasis.
[2]	VCFG	RW	0	VCFG: Validity Config.
[1]	V	RW	0	V: Validity.
[0]	DigEn	RW	0	Digital enable: 1 = converter enabled, 0 = converter disable.

8.28. Vendor Reserved (NID=23)

8.29. Dig0Mux Node (NID = 24)

8.29.1. *Dig0Mux WCap*

	Verb ID	Payload	Response
Get	F00	09	See bitfield table.

8.29.1.1. *Dig0Mux WCap*

Bit	Bitfield Name	RW	Reset	Description
[31.:24]	Rsvd2	R	00	Reserved.
[23.:20]	Type	R	3	Widget type: 0h = Out Converter; 1h = In Converter; 2h = Summing (Mixer); 3h = Selector (Mux); 4h = Pin Complex; 5h = Power; 6h = Volume Knob; 7h = Beep Generator; 8h-Eh = Reserved; Fh = Vendor Defined
[19.:16]	Delay	R	0	Number of sample delays through widget.
[15.:12]	Rsvd1	R	0	Reserved.
[11]	SwapCap	R	0	Left/right swap support: 1 = yes, 0 = no.
[10]	PwrCntrl	R	0	Power state support: 1 = yes, 0 = no.
[9]	DigitalStrm	R	0	Digital stream support: 1 = yes (digital), 0 = no (analog).
[8]	ConnList	R	1	Connection list present: 1 = yes, 0 = no.
[7]	UnsolCap	R	0	Unsolicited response support: 1 = yes, 0 = no.
[6]	ProcWidget	R	0	Processing state support: 1 = yes, 0 = no.
[5]	Stripe	R	0	Striping support: 1 = yes, 0 = no.
[4]	FormatOvrd	R	0	Stream format override: 1 = yes, 0 = no.
[3]	AmpParamOvrd	R	0	Amplifier capabilities override: 1 = yes, no.
[2]	OutAmpPrsnt	R	0	Output amp present: 1 = yes, 0 = no.
[1]	InAmpPrsnt	R	0	Input amp present: 1 = yes, 0 = no.
[0]	Stereo	R	1	Stereo stream support: 1 = yes (stereo), 0 = no (mono).

8.29.2. Dig0Mux ConLst

	Verb ID	Payload	Response
Get	F00	0E	See bitfield table.

8.29.2.1. Dig0Mux ConLst

Bit	Bitfield Name	RW	Reset	Description
[31..8]	Rsvd	R	000000	Reserved.
[7]	LForm	R	0	Connection list format: 1 = long-form (15-bit) NID entries, 0 = short-form (7-bit) NID entries.
[6..0]	ConL	R	03	Number of NID entries in connection list.

8.29.3. Dig0Mux ConLstEntry0

	Verb ID	Payload	Response
Get	F02	00	See bitfield table.

8.29.3.1. Dig0Mux ConLstEntry0

Bit	Bitfield Name	RW	Reset	Description
[31..24]	ConL3	R	00	Unused list entry.
[23..16]	ConL2	R	1D	ADC1Mux Selector widget (0x1D)
[15..8]	ConL1	R	1C	ADC0Mux Selector widget (0x1C)
[7..0]	ConL0	R	21	SPDIFOut0 Converter widget (0x21)

8.29.4. Dig0Mux ConSelectCtrl

	Verb ID	Payload	Response
Get	F01	00	See bitfield table.

8.29.4.1. Dig0Mux ConSelectCtrl

Bit	Bitfield Name	RW	Reset	Description
[31..2]	Rsvd	R	00000000	Reserved.
[1..0]	Index	RW	0	Connection select control index.

8.30. Dig2Mux Node (NID = 25)**8.30.1. Dig2Mux WCap**

	Verb ID	Payload	Response
Get	F00	09	See bitfield table.

8.30.1.1. Dig2Mux WCap

Bit	Bitfield Name	RW	Reset	Description
[31..24]	Rsvd2	R	00	Reserved.
[23..20]	Type	R	3	Widget type: 0h = Out Converter; 1h = In Converter; 2h = Summing (Mixer); 3h = Selector (Mux); 4h = Pin Complex; 5h = Power; 6h = Volume Knob; 7h = Beep Generator; 8h-Eh = Reserved; Fh = Vendor Defined
[19..16]	Delay	R	0	Number of sample delays through widget.
[15..12]	Rsvd1	R	0	Reserved.
[11]	SwapCap	R	0	Left/right swap support: 1 = yes, 0 = no.

8.30.1.1. *Dig2Mux WCap*

Bit	Bitfield Name	RW	Reset	Description
[10]	PwrCntrl	R	0	Power state support: 1 = yes, 0 = no.
[9]	DigitalStrm	R	0	Digital stream support: 1 = yes (digital), 0 = no (analog).
[8]	ConnList	R	1	Connection list present: 1 = yes, 0 = no.
[7]	UnsolCap	R	0	Unsolicited response support: 1 = yes, 0 = no.
[6]	ProcWidget	R	0	Processing state support: 1 = yes, 0 = no.
[5]	Stripe	R	0	Striping support: 1 = yes, 0 = no.
[4]	FormatOvrd	R	0	Stream format override: 1 = yes, 0 = no.
[3]	AmpParamOvrd	R	0	Amplifier capabilities override: 1 = yes, no.
[2]	OutAmpPrsnt	R	0	Output amp present: 1 = yes, 0 = no.
[1]	InAmpPrsnt	R	0	Input amp present: 1 = yes, 0 = no.
[0]	Stereo	R	1	Stereo stream support: 1 = yes (stereo), 0 = no (mono).

8.30.2. *Dig2Mux ConLst*

	Verb ID	Payload	Response
Get	F00	0E	See bitfield table.

8.30.2.1. *Dig2Mux ConLst*

Bit	Bitfield Name	RW	Reset	Description
[31..8]	Rsvd	R	000000	Reserved.

8.30.2.1. *Dig2Mux ConLst*

Bit	Bitfield Name	RW	Reset	Description
[7]	LForm	R	0	Connection list format: 1 = long-form (15-bit) NID entries, 0 = short-form (7-bit) NID entries.
[6.:0]	ConL	R	03	Number of NID entries in connection list.

8.30.3. *Dig2Mux ConLstEntry0*

	Verb ID	Payload	Response
Get	F02	00	See bitfield table.

8.30.3.1. *Dig2Mux ConLstEntry0*

Bit	Bitfield Name	RW	Reset	Description
[31.:24]	ConL3	R	00	Unused list entry.
[23.:16]	ConL2	R	1D	ADC1Mux Selector widget (0x1D)
[15.:8]	ConL1	R	1C	ADC0Mux Selector widget (0x1C)
[7.:0]	ConL0	R	22	SPDIFOut1 Converter widget (0x22)

8.30.4. *Dig2Mux ConSelectCtrl*

	Verb ID	Payload	Response
Get	F01	00	See bitfield table.

8.30.4.1. *Dig2Mux ConSelectCtrl*

Bit	Bitfield Name	RW	Reset	Description
[31..2]	Rsvd	R	00000000	Reserved.
[1..0]	Index	RW	0	Connection select control index.

8.31. DigBeep Node (NID = 26)

8.31.1. *DigBeep WCap*

	Verb ID	Payload	Response
Get	F00	09	See bitfield table.

8.31.1.1. *DigBeep WCap*

Bit	Bitfield Name	RW	Reset	Description
[31..24]	Rsvd3	R	00	Reserved.
[23..20]	Type	R	7	Widget type: 0h = Out Converter; 1h = In Converter; 2h = Summing (Mixer); 3h = Selector (Mux); 4h = Pin Complex; 5h = Power; 6h = Volume Knob; 7h = Beep Generator; 8h-Eh = Reserved; Fh = Vendor Defined
[19..4]	Rsvd2	R	0	Reserved.
[3]	AmpParOvrd	R	1	Amplifier capabilities override: 1 = yes, no.
[2]	OutAmpPrsnt	R	1	Output amp present: 1 = yes, 0 = no.
[1..0]	Rsvd1	R	0	Reserved.

8.31.2. DigBeep OutAmpCap

	Verb ID	Payload	Response
Get	F00	12	See bitfield table.

8.31.2.1. DigBeep OutAmpCap

Bit	Bitfield Name	RW	Reset	Description
[31]	Mute	R	1	Mute support: 1 = yes, 0 = no.
[30.:23]	Rsvd3	R	00	Reserved.
[22.:16]	StepSize	R	17	Size of each step in the gain range: 0 to 127 = .25dB to 32dB, in .25dB steps.
[15]	Rsvd2	R	0	Reserved.
[14.:8]	NumSteps	R	03	Number of gains steps (number of possible settings - 1).
[7]	Rsvd1	R	0	Reserved.
[6.:0]	Offset	R	03	Indicates which step is 0dB

8.31.3. DigBeep OutAmpLeft

	Verb ID	Payload	Response
Get	BA0	00	See bitfield table.

8.31.3.1. DigBeep OutAmpLeft

Bit	Bitfield Name	RW	Reset	Description
[31.:8]	Rsvd2	R	000000	Reserved.
[7]	Mute	RW	0	Amp mute: 1 = muted, 0 = not muted.

8.31.3.1. *DigBeep OutAmpLeft*

Bit	Bitfield Name	RW	Reset	Description
[6.:2]	Rsvd1	R	00	Reserved.
[1.:0]	Gain	RW	0	Amp gain step number (see OutAmp-Cap parameter pertaining to this widget).

8.31.4. *DigBeep Gen*

	Verb ID	Payload	Response
Get	F0A	00	See bitfield table.

8.31.4.1. *DigBeep Gen*

Bit	Bitfield Name	RW	Reset	Description
[31.:8]	Rsvd	R	000000	Reserved.
[7.:0]	Divider	RW	00	Enable internal PC-Beep generation. Divider == 00h disables internal PC Beep generation and enables normal operation of the codec. Divider != 00h generates the beep tone on all Pin Complexes that are currently configured as outputs. The HD Audio spec states that the beep tone frequency = (48kHz HD Audio SYNC rate) / (4*Divider), producing tones from 47 Hz to 12 kHz (logarithmic scale). This part can selectively generate tones with frequency = 48KHz * (257 - Divider) / 1024, yielding a linear range from 12kHz to 93.75Hz in steps of 46.875Hz. If the FreqShift bit is set, then the beep tones generated have frequency = 48KHz * (513 - Divider) / 1024, yielding a range of 24kHz to 12093.75Hz in steps of 46.875Hz.

8.31.5. DigBeep Mode

	Verb ID	Payload	Response
Get	FE0	00	See bitfield table.

8.31.5.1. DigBeep Mode

Bit	Bitfield Name	RW	Reset	Description
[31..2]	Rsvd1	R	00000000	Reserved.
[1]	FreqShift	RW	0	Digital PCBeep frequency range shift (for linear mode only): 0 = 47Hz-12kHz, 1 = 12.047kHz-24kHz.
[0]	LinearSel	RW	0	Linear PCBeep frequency select. 0 = HD Audio Rev.1.0 frequencies ; 1 = linear frequencies

8.32. VolumeKnob Node (NID = 27)**8.32.1. VolumeKnob WCap**

	Verb ID	Payload	Response
Get	F00	09	See bitfield table.

8.32.1.1. VolumeKnob WCap

Bit	Bitfield Name	RW	Reset	Description
[31..24]	Rsvd2	R	00	Reserved.
[23..20]	Type	R	6	Widget type: 0h = Out Converter; 1h = In Converter; 2h = Summing (Mixer); 3h = Selector (Mux); 4h = Pin Complex; 5h = Power; 6h = Volume Knob; 7h = Beep Generator; 8h-Eh = Reserved; Fh = Vendor Defined
[19..0]	Rsvd1	R	0	Reserved.

8.32.2. VolumeKnob VolKnobCap

	Verb ID	Payload	Response
Get	F00	13	See bitfield table.

8.32.2.1. VolumeKnob VolKnobCap

Bit	Bitfield Name	RW	Reset	Description
[31..8]	Rsvd	R	000000	Reserved.
[7]	Delta	R	1	Indicates if software can write a base volume to the Volume Control Knob.
[6..0]	NumSteps	R	7F	Number of gains steps (number of possible settings - 1).

8.32.3. VolumeKnob ConLst

	Verb ID	Payload	Response
Get	F00	0E	See bitfield table.

8.32.3.1. VolumeKnob ConLst

Bit	Bitfield Name	RW	Reset	Description
[31..8]	Rsvd	R	000000	Reserved.
[7]	LForm	R	0	Connection list format: 1 = long-form (15-bit) NID entries, 0 = short-form (7-bit) NID entries.
[6..0]	ConL	R	02	Number of NID entries in connection list.

8.32.4. VolumeKnob ConLstEntry0

	Verb ID	Payload	Response
Get	F02	00	See bitfield table.

8.32.4.1. VolumeKnob ConLstEntry0

Bit	Bitfield Name	RW	Reset	Description
[31..24]	ConL3	R	00	Unused list entry.
[23..16]	ConL2	R	00	Unused list entry.
[15..8]	ConL1	R	11	DAC1 Converter widget (0x11)
[7..0]	ConL0	R	10	DAC0 Converter widget (0x10)

8.32.5. VolumeKnob UnsolResp

	Verb ID	Payload	Response
Get	F08	00	See bitfield table.

8.32.5.1. VolumeKnob UnsolResp

Bit	Bitfield Name	RW	Reset	Description
[31..8]	Rsvd2	R	000000	Reserved.
[7]	En	RW	0	Unsolicited response enable: 1 = enabled, 0 = disabled.
[6]	Rsvd1	R	0	Reserved.
[5..0]	Tag	RW	00	Software programmable field returned in top six bits (31:26) of every Unsolicit- ed Response generated by this node.

8.32.6. VolumeKnob Cntrl

	Verb ID	Payload	Response
Get	F0F	00	See bitfield table.

8.32.6.1. VolumeKnob Cntrl

Bit	Bitfield Name	RW	Reset	Description
[31..8]	Rsvd	R	000000	Reserved.
[7]	Direct	RW	0	Direct = 1 causes the volume control to directly control the hardware volume of the slave amps. Direct = 0 causes unsolicited responses to be generated.
[6..0]	Volume	RW	7F	Volume, specified in steps of amplifier gain

8.32.7. VolumeKnob Update

	Verb ID	Payload	Response
Get	FE0	00	See bitfield table.

8.32.7.1. VolumeKnob Update

Bit	Bitfield Name	RW	Reset	Description
[31..5]	Rsvd	R	0000000	Reserved.
[4]	Continuous	RW	1	Allow continuous incrementing/decrementing of the volume knob value.

8.32.7.1. *VolumeKnob Update*

Bit	Bitfield Name	RW	Reset	Description
[3..1]	Rate	RW	0	Volume knob update rate, for continuous mode and de-bouncing (0..7 = 2.5..20Hz, in increments of 2.5Hz)
[0]	Enable	RW	0	Volume knob Enable (0=pin used for digital microphone. 1=pin used for volume control)"

9. **DISCLAIMER**

While the information presented herein has been checked for both accuracy and reliability, manufacturer assumes no responsibility for either its use or for the infringement of any patents or other rights of third parties, which would result from its use. No other circuits, patents, or licenses are implied. This product is intended for use in normal commercial applications. Any other applications, such as those requiring extended temperature range, high reliability, or other extraordinary environmental requirements, are not recommended without additional processing by manufacturer. Manufacturer reserves the right to change any circuitry or specifications without notice. Manufacturer does not authorize or warrant any product for use in life support devices or critical medical instruments.

10. PINOUTS

10.1. Pin Assignment - 32 pad

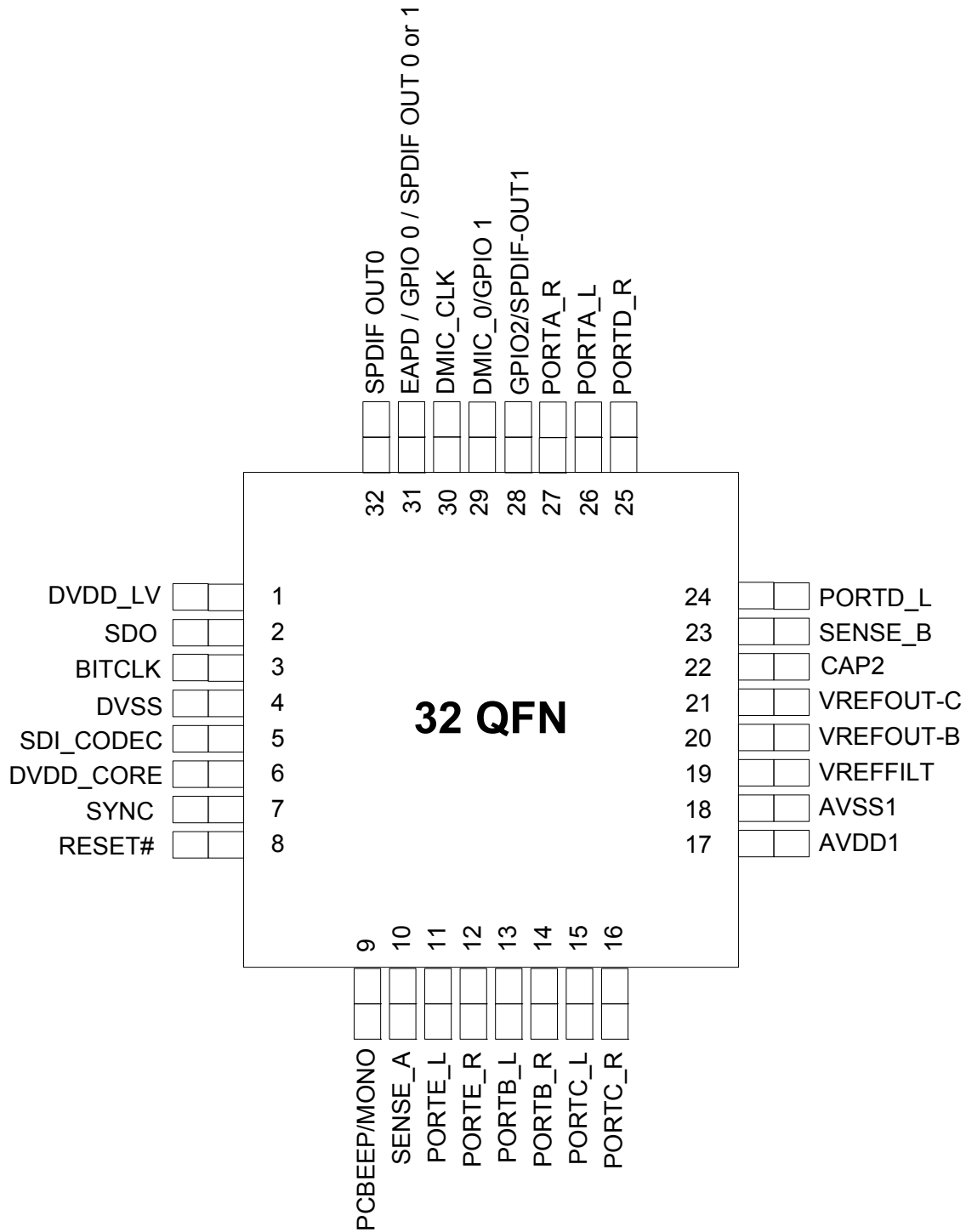

Figure 15. 32 Pad Assignment

10.2. Pin Assignment - 48 pad

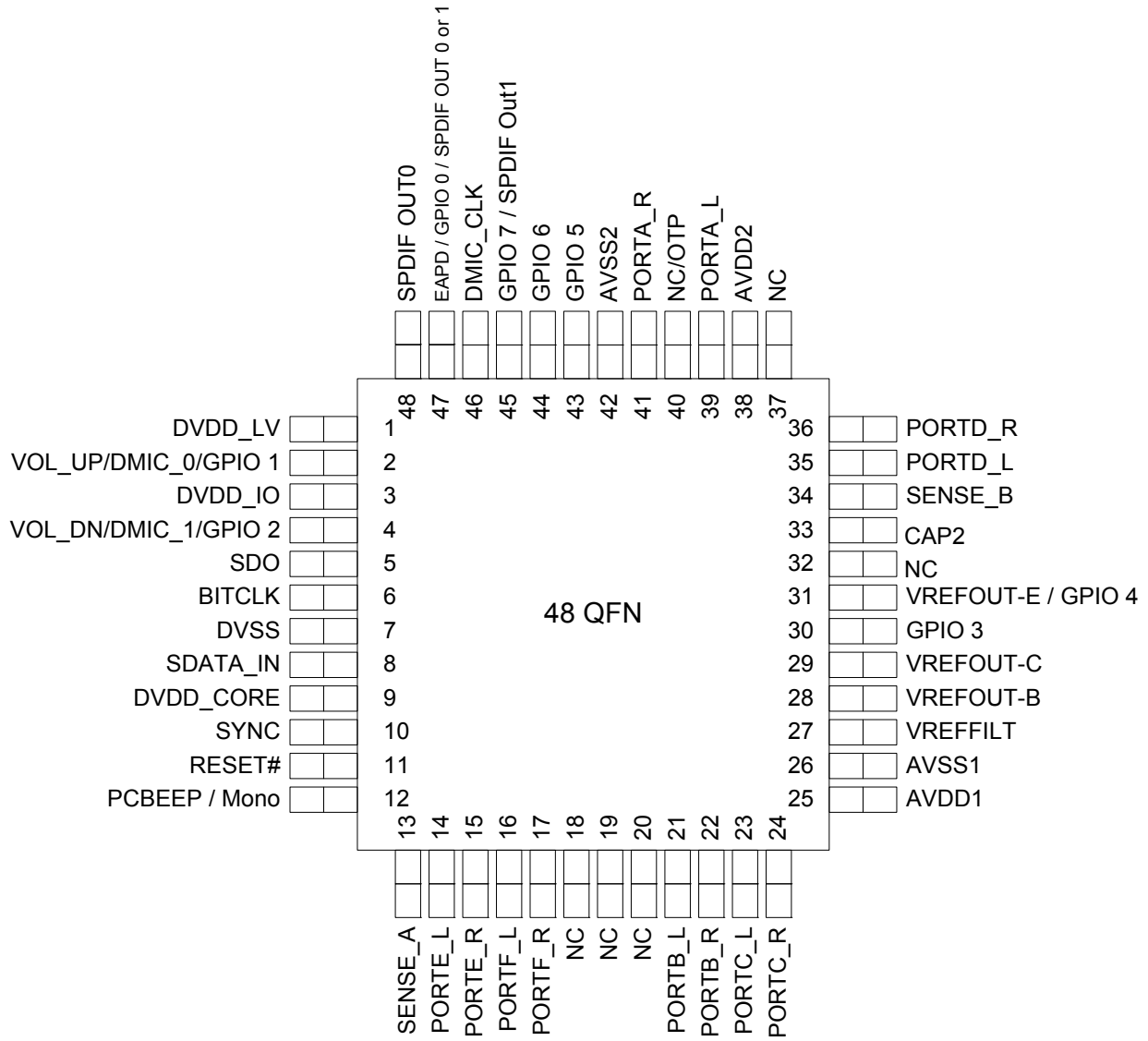

Figure 16. 48 Pad Assignment

10.3. Pin Descriptions

Table 19. Pin descriptions

Pin Name	Pin Function	I/O	Internal Pull-up/Pull-down	48 pin location	32 Pin location
DVDD_LV	Low Voltage Digital Vdd = 1.5V or 1.8V for core logic. Connected to internal regulation which is always on. Please see reference design for more information.	I(Digital)	None	1	1
VOL_UP/DMIC0/GPIO1	Volume Control OR Digital Mic 0 Input/General Purpose I/O	I/O(Digital)	Pull-up 50K GPIO/VOL or Pull-down 50k with Digital Mic	2	29
DVDD_IO	HDA Interface Voltage (1.5V or 3.3V)	I(Digital)	None	3	NA, for 32QFN, orderable part number drives the permanent setting of the HDA voltage
VOL_DN/DMIC1/GPIO2	SPDIF1/Digital Mic 1 Input/General Purpose I/O	I/O(Digital)	Pull-up 50K GPIO/VOL or Pull-down 50k with Digital Mic	4	NA
SDO	HD Audio Serial Data output (inbound stream)	I/O(Digital)	None	5	2
BITCLK	HD Audio Bit Clock	I(Digital)	None	6	3
DVSS	Digital Ground	I(Digital)	None	7	4
SDI_CODEC	HD Audio Serial Data (outbound stream), audio module	I/O(Digital)	None	8	5
DVDD_CORE	Digital Vdd= 3.3V for I/O, PLL and internal regulator	I(Digital)	None	9	6
SYNC	HD Audio Frame Sync	I(Digital)	None	10	7
RESET#	HD Audio Reset	I(Digital)	None	11	8
PCBEEP/MONO	Mono / PC Beep	I(Analog)	None	12	9
SENSE_A	Jack insertion detection Ports A,B,C,D	I(Analog)	None	13	10
PORTE_L	Port E Input Left	I(Analog)	None	14	11
PORTE_R	Port E Input Right	I(Analog)	None	15	12
PORTF_L	Port F Output Left	O(Analog)	None	16	NA
PORTF_R	Port F Output Right	O(Analog)	None	17	NA
PORTB_L	Port B Input Left	I(Analog)	None	21	13
PORTB_R	Port B Input Right	I(Analog)	None	22	14
PORTC_L	Port C Input Left	I(Analog)	None	23	15
PORTC_R	Port C Input Right	I(Analog)	None	24	16

Table 19. Pin descriptions

Pin Name	Pin Function	I/O	Internal Pull-up/Pull-down	48 pin location	32 Pin location
AVDD1	Analog Vdd=4.75V or 3.3V	I(Analog)	None	25	17
AVSS1	Analog Ground	I(Analog)	None	26	18
VREFFILT	Analog Virtual Ground	O(Analog)	None	27	19
VREFOUT-B	Reference Voltage out drive (intended for mic bias) for Port B	O(Analog)	None	28	20
VREFOUT-C	Reference Voltage out drive (intended for mic bias) for Port C	O(Analog)	None	29	21
GPIO3	Analog GPIO3	I/O(Analog)	Pull-Up 50k with GPIO	30	NA
VREFOUT-E / GPIO4	Reference Voltage out drive (intended for mic bias) for Port E / Analog GPIO4	I/O(Analog)	None	31	NA
CAP2	ADC reference Cap	O(Analog)	None	33	22
SENSE_B/NC	Jack insertion detection Ports E, F	I(Analog)	None	34	23
PORT-D_L	Port D Output Left	O(Analog)	None	35	24
PORT-D_R	Port D Output Right	O(Analog)	None	36	25
NC			None	37	NA
AVDD2	Analog Vdd=5.0V or 3.3V	I(Analog)	None	38	NA
PORTA_L (HP)	Port A Output Left	O(Analog)	None	39	26
NC			None	40	NA
PORTA_R (HP)	Port A Output Right	O(Analog)	None	41	27
AVSS2	Analog Ground	I(Analog)	None	42	NA
GPIO5	General Purpose I/O	I/O(Digital)	Pull-up 50K	43	NA
GPIO6	General Purpose I/O	I/O(Digital)	Pull-up 50K	44	NA
SPDIF-OUT1/GPIO7	Output from second SPDIF converter or General Purpose I/O	I/O(Digital)	Pull-up 50K (GPIO) Pull-down 50K (SPDIF)	45	28
DMIC_CLK	Digital Mic Output Clock	O(Digital)	Pull-down 50k	46	30
GPIO0/EAPD/SPDIF-OUT 0or1	General Purpose I/O,EAPD, SPDIF Out from first or second SPDIF converter	I/O(Digital)	Pull-down 50K	47	31
S/SPDIF-OUT0	Output from first SPDIF converter(50K internal pull-down	O(Digital)	50K internal pull-down	48	32

11. PACKAGE OUTLINE AND PACKAGE DIMENSIONS

Package dimensions are kept current with JEDEC Publication No. 95

11.1. 32-Pad QFN Package

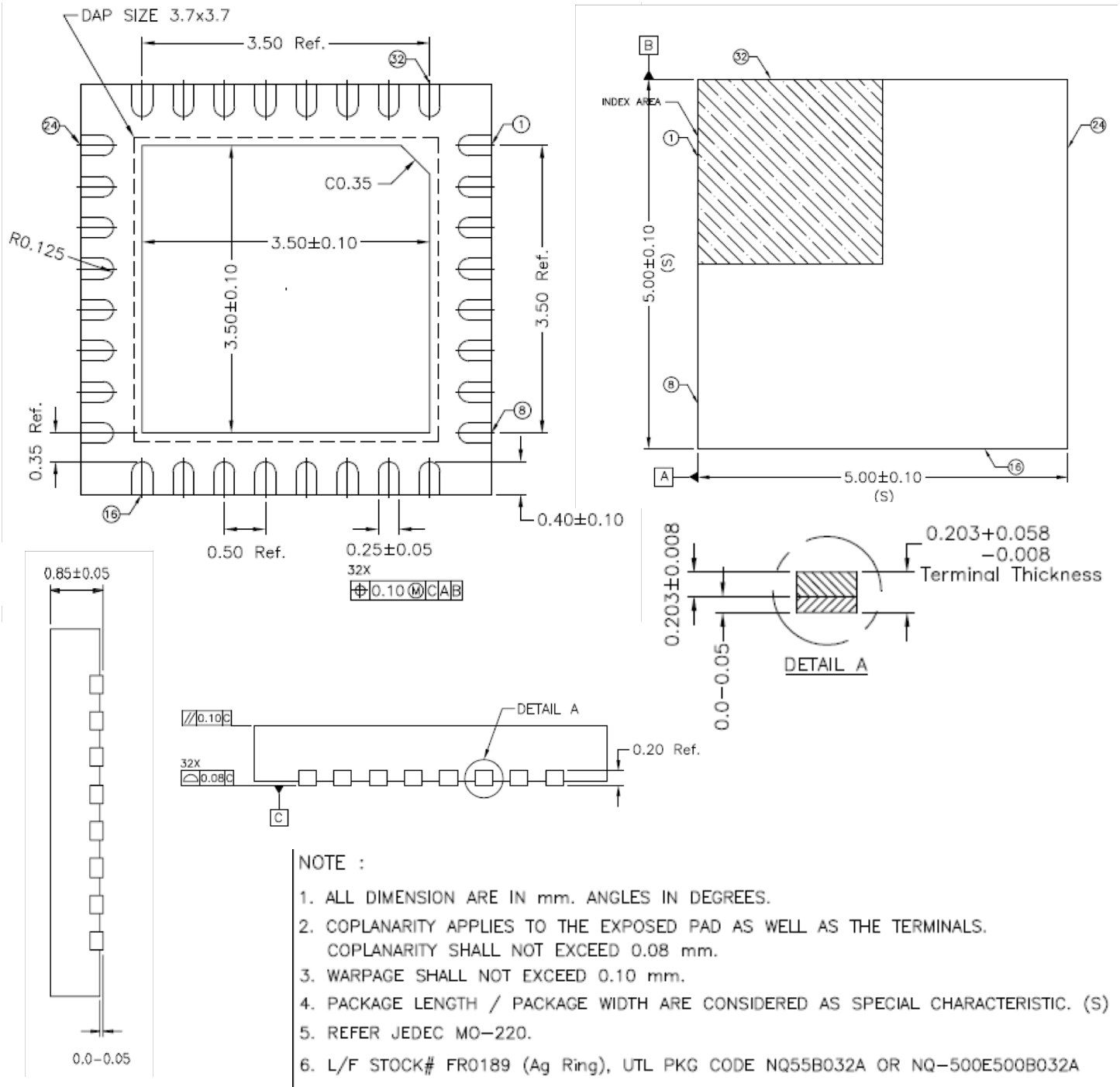

Figure 17. 32-pad QFN Package Drawing

11.2. 48-Pad QFN Package

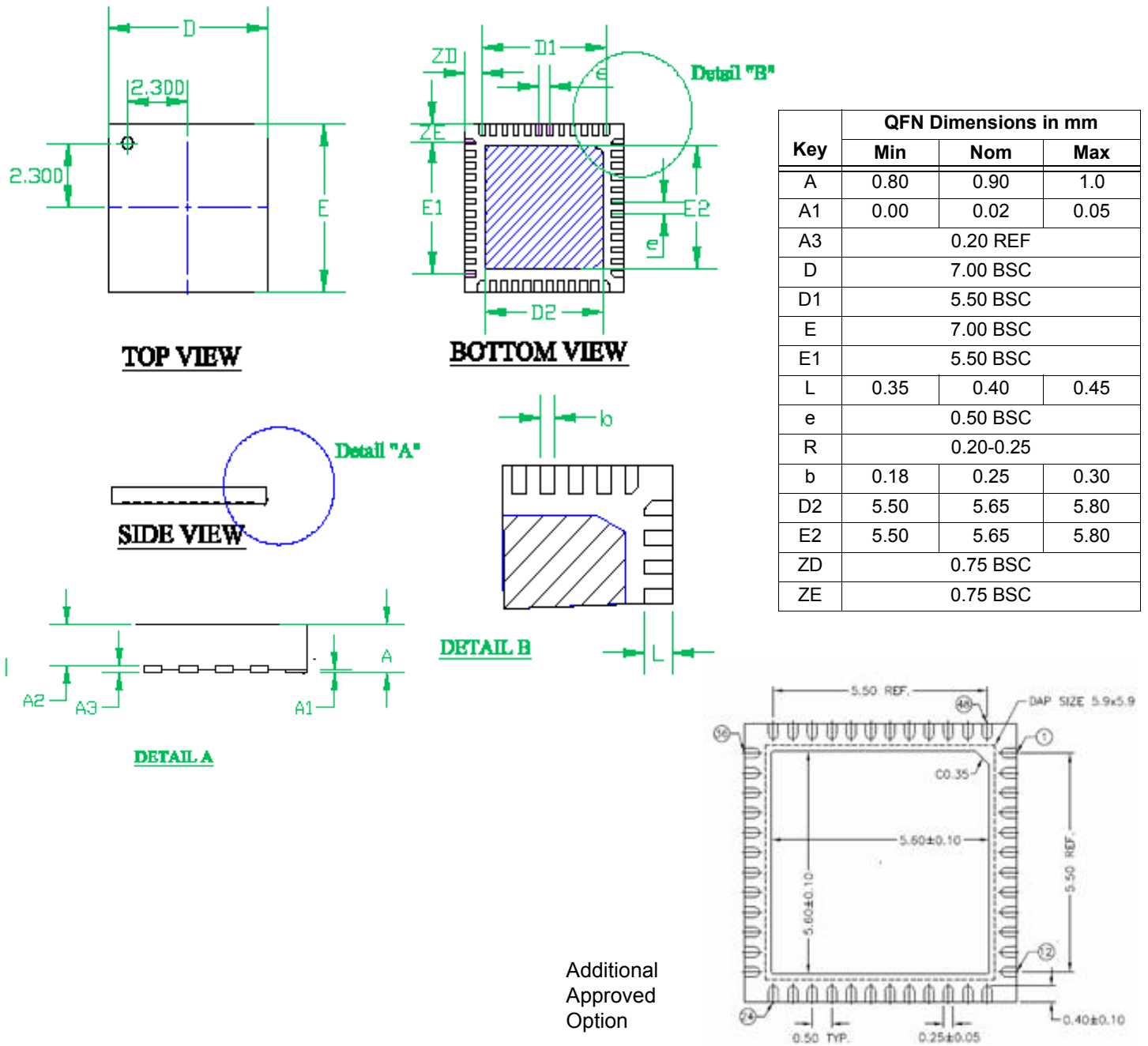

Figure 18. 48-pad QFN Package Drawing

12. SOLDER REFLOW PROFILE

12.1. Standard Reflow Profile Data

Note: These devices can be hand soldered at 360 °C for 3 to 5 seconds.

FROM: IPC / JEDEC J-STD-020C "Moisture/Reflow Sensitivity Classification for Nonhermetic Solid State Surface Mount Devices" (www.jedec.org/download).

Table 20. Standard Reflow Profile

Profile Feature	Pb Free Assembly
Average Ramp-Up Rate ($T_{s_{max}} - T_p$)	3 °C / second max
Preheat: Temperature Min ($T_{s_{min}}$) Temperature Max ($T_{s_{max}}$) Time ($t_{s_{min}} - t_{s_{max}}$)	150 °C 200 °C 60 - 180 seconds
Time maintained above: Temperature (T_L) Time (t_L)	217 °C 60 - 150 seconds
Peak / Classification Temperature (T_p)	See "Package Classification Reflow Temperatures" .
Time within 5 °C of actual Peak Temperature (t_p)	20 - 40 seconds
Ramp-Down rate	6 °C / second max
Time 25 °C to Peak Temperature	8 minutes max

Note: All temperatures refer to topside of the package, measured on the package body surface.

Figure 19. Solder Reflow Profile

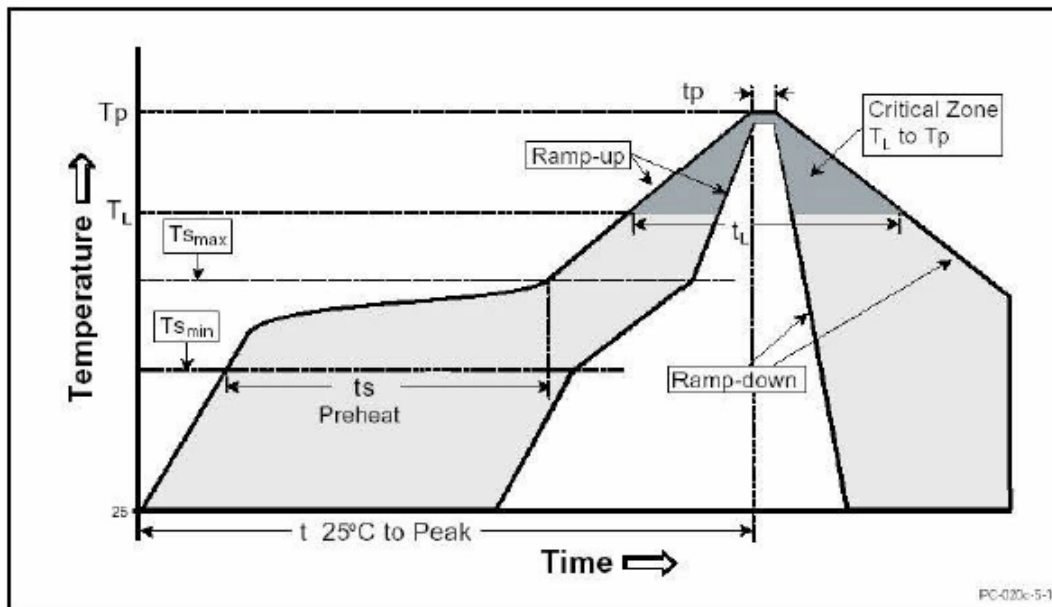

12.2. Pb Free Process - Package Classification Reflow Temperatures

Table 21. Pb-Free Process Reflow

Package Type	MSL	Reflow Temperature
QFN 32-pad	3	260 °C
QFN 48-pad	3	260 °C

13. REVISION HISTORY

Revision	Date	Description of Change
0.5	Dec. 2007	initial release
0.55	Jan. 2008	corrected footnotes on power supply numbers and D0 Didd/Aidd value
0.8	Jan. 2008	added widget details, corrected ESD/latchup specification/description, corrected value of THD+N specifications to dBr.
0.85	April 10, 2008	updated 32QFN package diagram to include package thickness
0.86	April 16, 2008	corrected pin28 in 32QFN in pin table
0.90	November 10, 2008	removed confidential tags, corrected 32QFN widget and block diagrams, clarified DMIC1 and Port_F as 48QFN package only
0.91	November 14, 2008	Updated orderable part numbers to reflect "B3" and "B4" seperate part numbers for the 1.5V and 3.3V HD Audio signaling
1.0	January 8, 2009	Removed preliminary tags
1.0a	July 29, 2009	Corrected Pin 1 description in pin table related to the internal regulator. Added request to see reference design for more information on Pin 1..
1.0b	November 2009	Clarification of Pin 1 in 32QFN package.



Innovate with IDT audio for high fidelity. Contact:

www.IDT.com

For Sales

800-345-7015
408-284-8200
Fax: 408-284-2775

For Tech Support

HA.CM@idt.com

Corporate Headquarters

Integrated Device Technology, Inc.
6024 Silver Creek Valley Road
San Jose, CA 95138
United States
800 345 7015
+408 284 8200 (outside U.S.)

Asia Pacific and Japan

Integrated Device Technology
Singapore (1997) Pte. Ltd.
Reg. No. 199707558G
435 Orchard Road
#20-03 Wisma Atria
Singapore 238877
+65 6 887 5505

Europe

IDT Europe, Limited
Prime House
Barnett Wood Lane
Leatherhead, Surrey
United Kingdom KT22 7DE
+44 1372 363 339