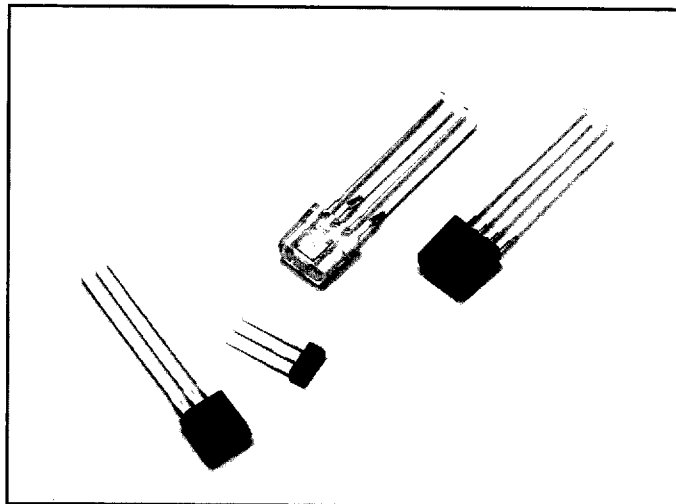

PHOTO ICs

A photodiode and signal processing circuit are integrated.

Photo ICs are intelligent light sensors consisting of a photodiode, signal processing circuit and signal output circuit. Molded in subminiature packages, these photo ICs are especially suited for miniaturization of electronic equipment. Various types are available to meet extensive applications. Typical photo ICs available from Hamamatsu are listed below.

Type No.	Product Name	Features
S2827 S2828	Photo IC sensor	Amplifier and Schmitt trigger circuit are integrated. Digital output, TTL compatible
S4282-11 S4285-40 (High-sensitivity type)	Light modulation Photo IC	Built-in oscillator and LED driver circuit enable optical synchronous detection under background light. Digital output, TTL compatible
S4810	Low voltage drive photo IC	Low voltage operation (2.2 to 7V), high sensitivity, low current consumption



CHARGE SENSITIVE AMPLIFIER

H4083

For detection of radiation and high-energy particles

The H4083 is a hybrid type low-noise amplifier that can be used in a wide range of applications including soft X-ray and low to high energy gamma-ray spectrometry. The H4083 is optimized for use with the Hamamatsu PIN silicon photodiode (S3590 and S3204 series). In particular, since the S3590 series can be directly mounted on the reverse side of the H4083, there will be no trouble from increases in stray capacitance. Moreover, its compactness and light weight render freedom to the design and development of a detector. Hamamatsu will modify the existing types or will design and manufacture completely new types with circuit components and configurations that match your requirements.

Type No.	Feedback Capacitance Cf (pF)	Feedback Resistance Rf (MΩ)	Charge Gain (V/coulomb)	Equivalent Input Noise Electrons (electrons FWHM)
H4083	2	50	0.5	550

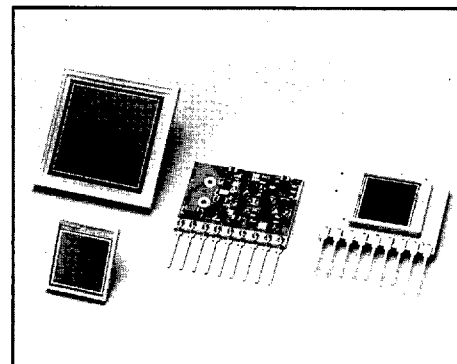

PHOTOSENSOR AMPLIFIER

C2719

Amplifies a low level photocurrent with low noise

The Hamamatsu C2719 Photosensor Amplifier is a low-noise current-to-voltage conversion amplifier used to amplify the very low photocurrents from a photodiode. Since the C2719 operates from dry batteries, it can be readily used anywhere and there is no problem with noise pickup from power supply lines. The photocurrent detection sensitivity can be chosen according to the amount of signal. Fine zero adjustment is possible with good resolution. As options, the S2281 series photodiodes equipped with a BNC connector and the E2573 coaxial cable (1m) with BNC connectors at both ends are available.

Type No.	Detection Sensitivity	Dimensions
C2719	10 ⁹ /10 ⁷ /10 ⁵ (V/A)	114W×39H×90D(mm)



Dimensional Outlines

Unit : mm

1 S1226-18BQ etc.

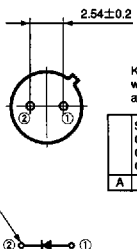
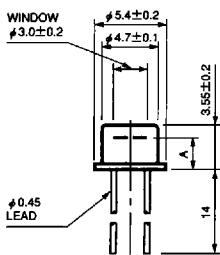

K type (borosilicate glass) window protrudes 0.1mm Max. above the rim.

S1226 Series	S1190
G1115	S1336 Series
G1735	S2386-18K
G1961	
A	2.4

KSPDA0047EA

2 S2386-18L

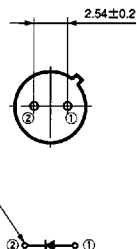
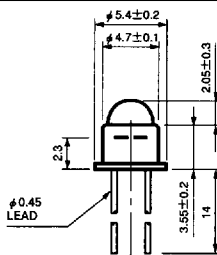

COMMON TO CASE

KSPDA0048EA

3 S1190-01 etc.

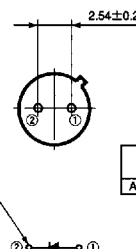
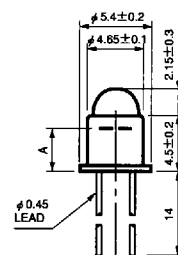

COMMON TO CASE

S1190-01	G3067
	G3297
A	2.4

KPINA0029EA

4 S1190-13

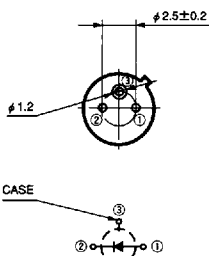
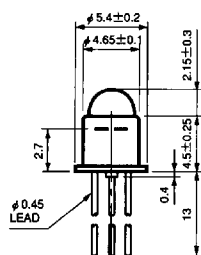

CASE

KPINA0030EA

5 S2216-01 etc.

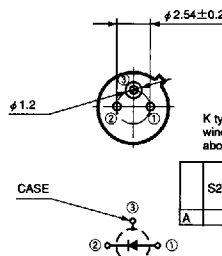
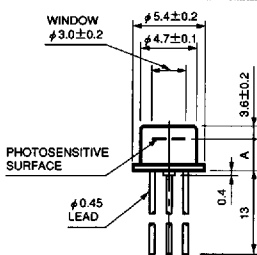

K type (borosilicate glass) window protrudes 0.1mm Max. above the rim.

S2216-01	S2838, S2840	S1190-03
	S4280, S4751	
	S4752, S4753	
A	2.6	2.7

KPINA0022EA

6 S5531, S5532, S5533

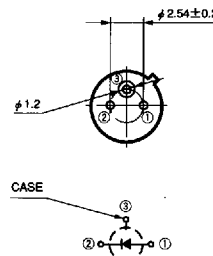
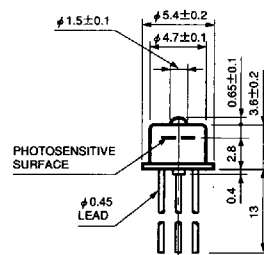

CASE

KPINA0023EA

7 S2381, S2382, S2383

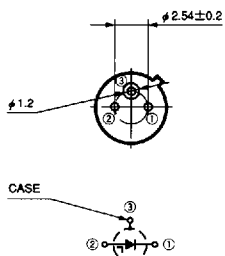
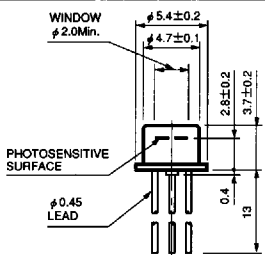

CASE

KAPDA0010EA

8 S1226-5BQ etc.

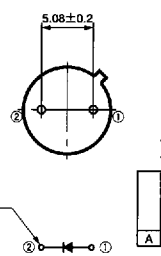
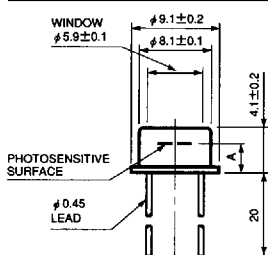

K type (borosilicate glass) window protrudes 0.2mm Max. above the rim.

S1226 Series	S2386 Series
G1118, G1738	S1336 Series
G125-02	S1223
G1746, G1962	S1223-01
A	2.9

KSPDA0049EA

9 S3072

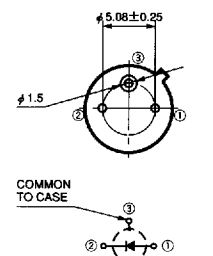
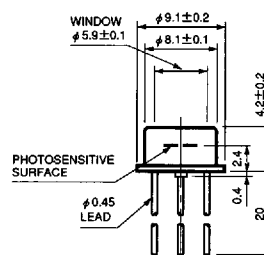

COMMON TO CASE

The window protrudes 0.2mm Max. above the rim.

KPINA0024EA

10 S3884

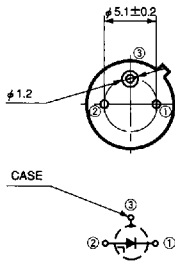
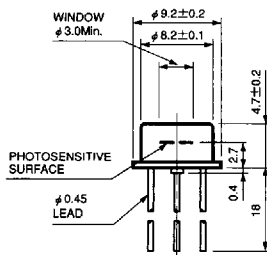

KAPDA0011EA

11 S2384

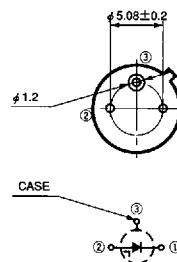
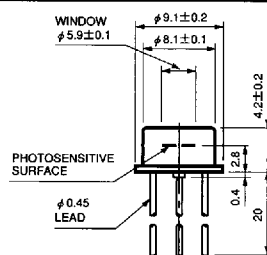

The window protrudes 0.2mm Max. above the rim.

KAPDA0012EA

12 S1226-8BQ etc.

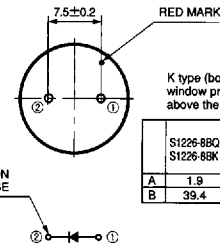
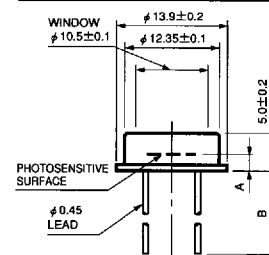

K type (borosilicate glass) window protrudes 0.3mm Max. above the rim.

	S1226-8BQ S1226-8BK	S2386-8BK S1336-8BQ S1336-8BK	G1117, G1737 G1127-02 G1747 G1963
A	1.9	1.8	1.9
B	39.4	39.4	15.0

KSPDA0050EA

13 S3071

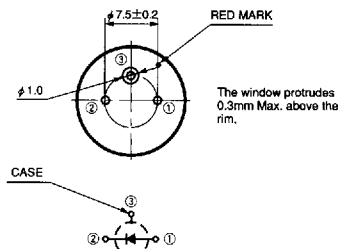
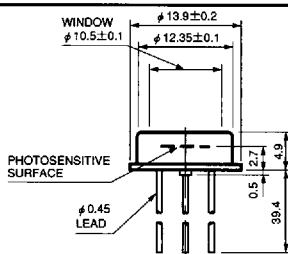

The window protrudes 0.3mm Max. above the rim.

KPINA0027EA

14 S1863-01

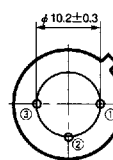
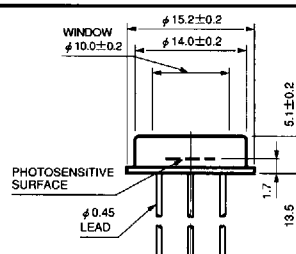

The window protrudes 0.3mm Max. above the rim.

KPINA0028EA

15 S2385

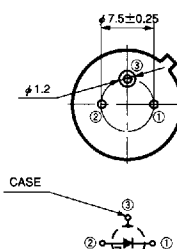
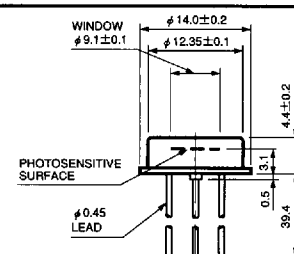

KAPDA0013EA

16 S3883

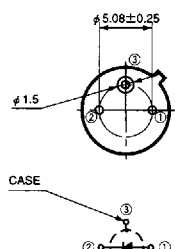
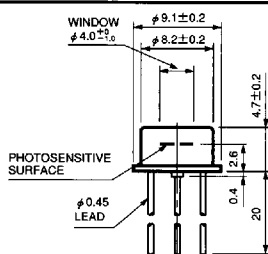

KPINA0025EA

17 S3399

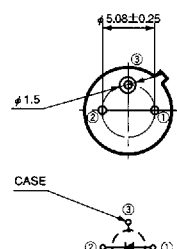
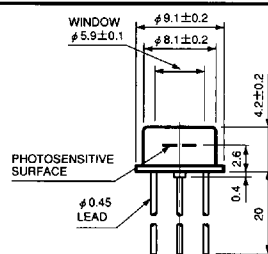

The window protrudes 0.2mm Max. above the rim.

KPINA0026EA

18 S1227-16BQ etc.

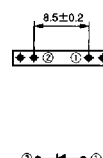
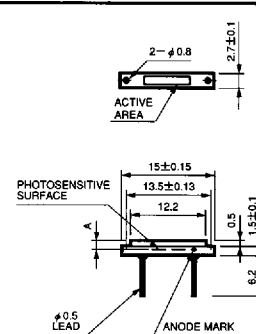

	S1227-16BQ	S1337-16BQ
A	0.85	0.95

KSPDA0033EA

Unit : mm

19 S1227-16BR etc.

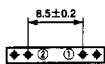
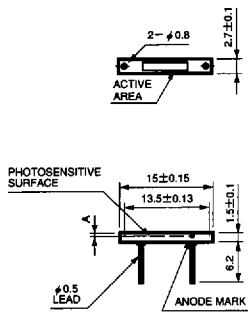

	S1227-16BQ	S1337-16BR S2387-16R
A	0.35	0.45



KSPDA0034EB

20 S1227-33BQ etc.

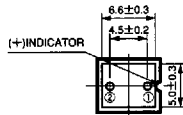
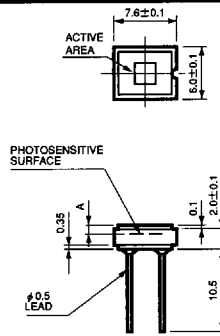

	S1227-33BQ	S1337-33BQ
A	0.75	0.85



KSPDA0035EB

21 S1227-33BR etc.

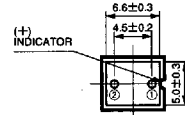
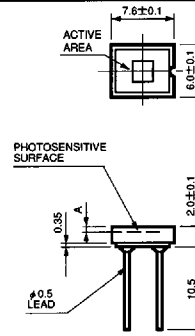

	S1227-33BR	S1337-33BR S2387-33R
A	0.65	0.75



KSPDA0036EB

22 S1227-66BQ etc.

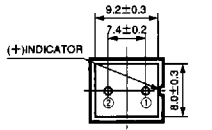
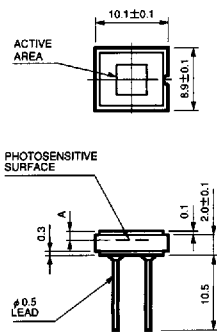

	S1227-66BQ	S1337-66BQ
A	0.75	0.85



KSPDA0037EA

23 S1227-66BR etc.

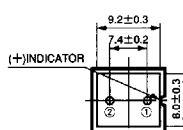
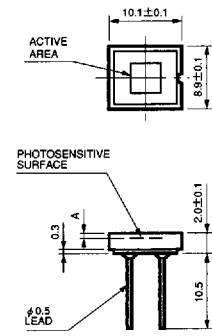

	S1227-66BR G1120	S1337-66BR S2387-66R
A	0.65	0.75



KSPDA0038EA

24 S1227-1010BQ etc.

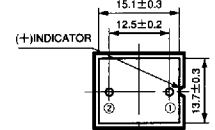
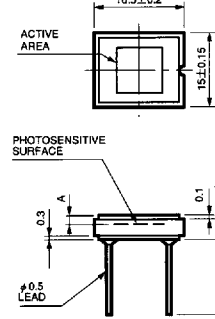

	S1227-1010BQ G2119	S1337-1010BQ
A	0.9	1.0



KSPDA0039EA

25 S1227-1010BR etc.

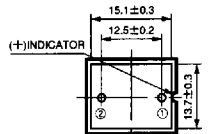
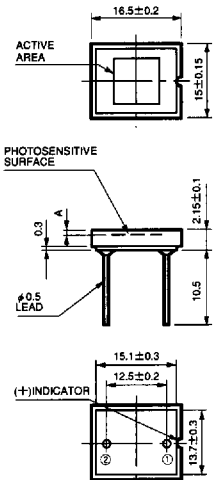

	S1227-1010BR	S1337-1010BR S2387-1010R
A	0.8	0.9



KSPDA0040EA

26 S5106

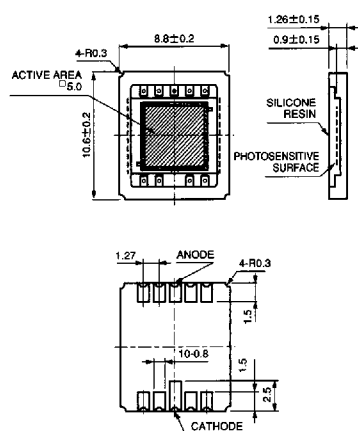

KPINA0002EA

27 S5107

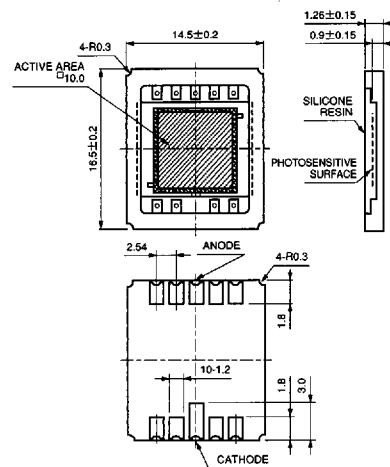

KPINA0013EA

With respect to the outer dimensions, the burr is 0.3mm maximum on one side

28 S3590 Series

29 S3588-03

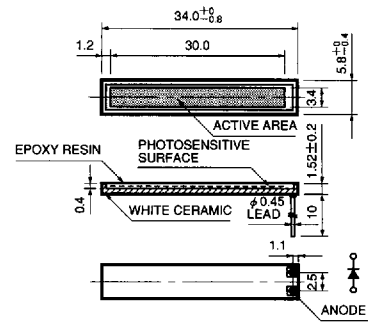
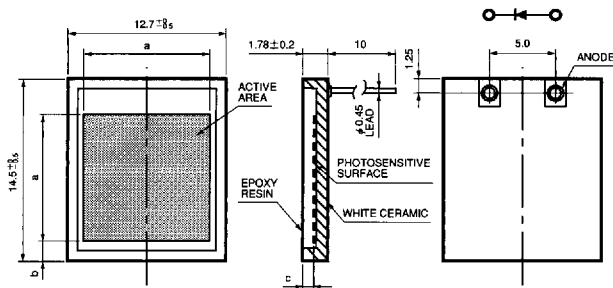

	-01	-03	-05
a	10.0	10.0	9.0
b	1.4	1.4	1.9
c	0.8	0.7	0.5

KPINA0014EB

KSPDA0051EA

30 S1087-01, S1087-11

31 G1118, G1738

32 S1087

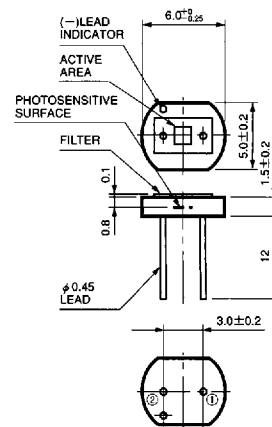
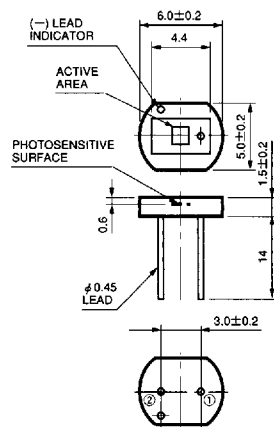
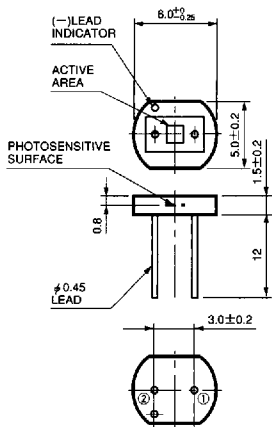

KSPDA0052EA



KGPDA0002EA



KSPDA0053EA

33 S1133-01, S1133-14

34 S1133

35 S1787 Series

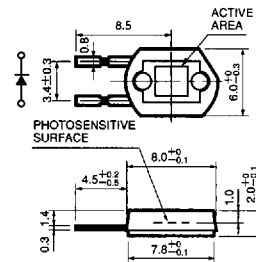
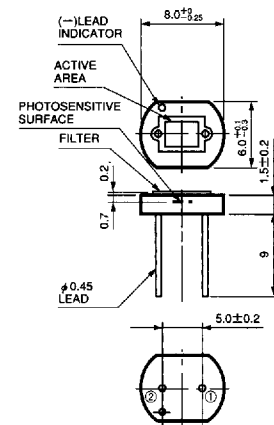
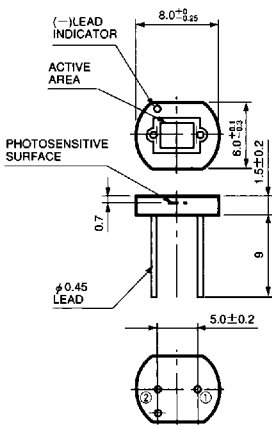

KSPDA0054EA



KSPDA0055EA

KSPDA0056EA

Unit : mm

36 S2164

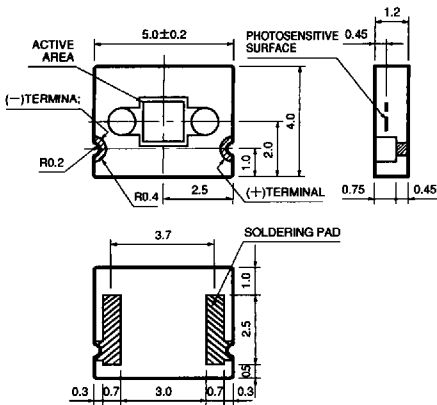

KSPDA0057EA

37 S2506 Series

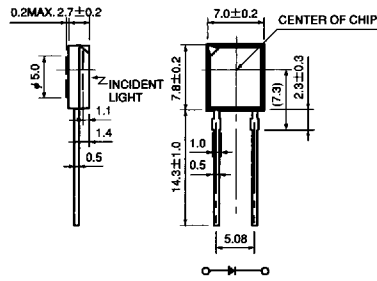

KPINA0031EA

38 S2551, S4036

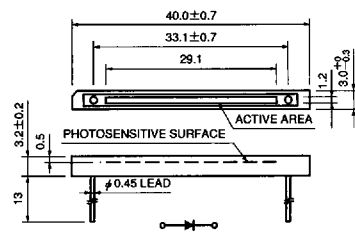

KSPDA0058EA

39 S4011, S4160

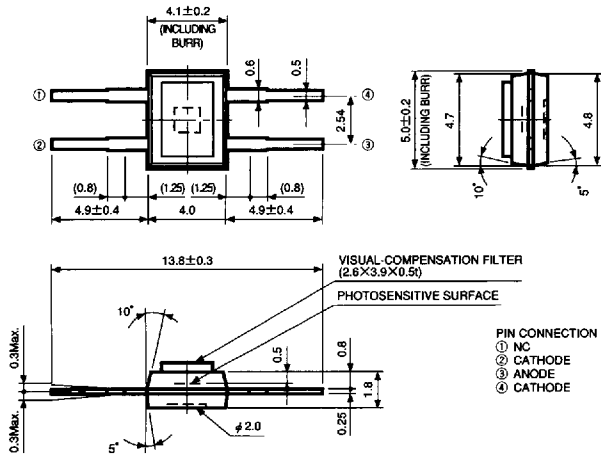

KSPDA0059EA

40 S3321, S4011-02, S4160-02

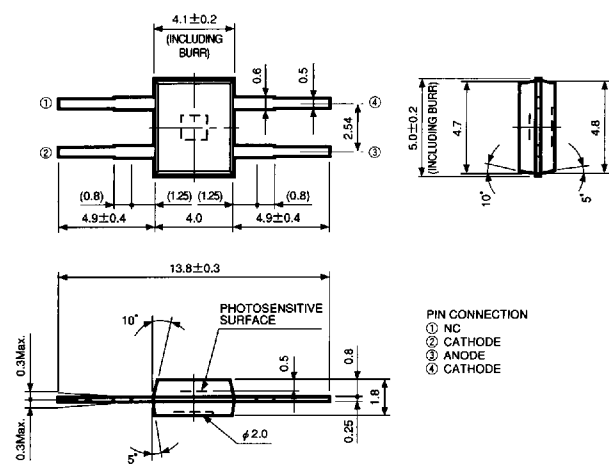

KSPDA0060EA

41 S2833

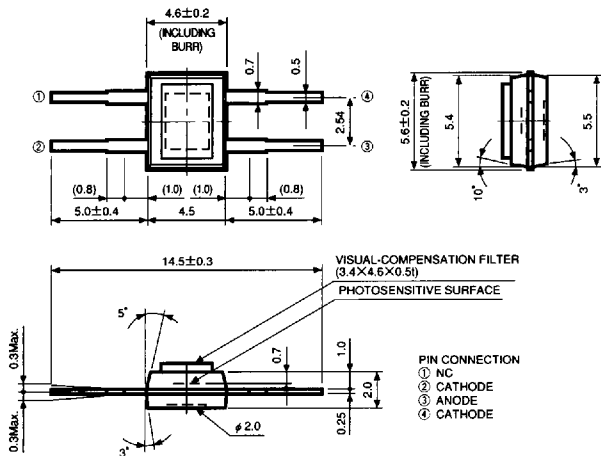

KSPDA0061EA

42 S2833-01

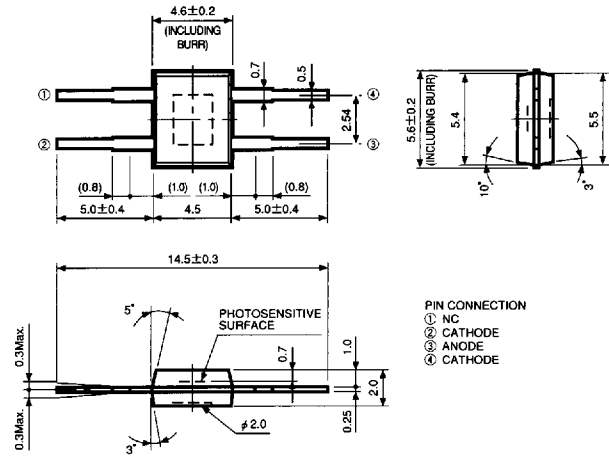

KSPDA0062EA

43 G2711-01

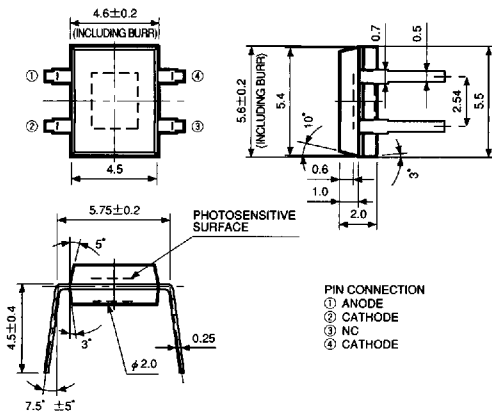

KGPDA0003EA

44 S2833-04, S3407-01, S4707-01

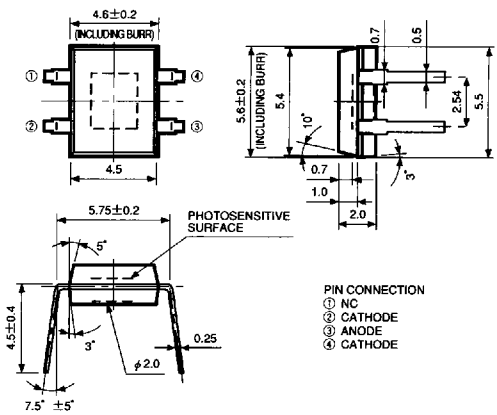

KSPDA0068EA

45 S4160-01

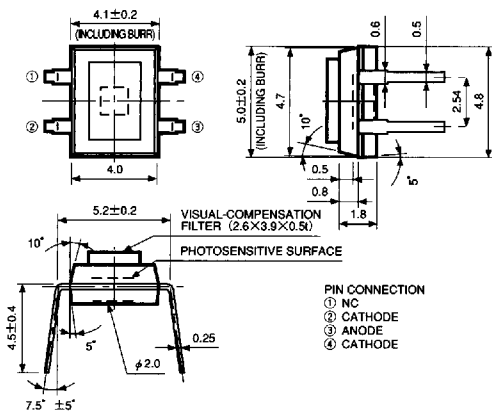

KSPDA0064EA

46 S4797-01, S5077

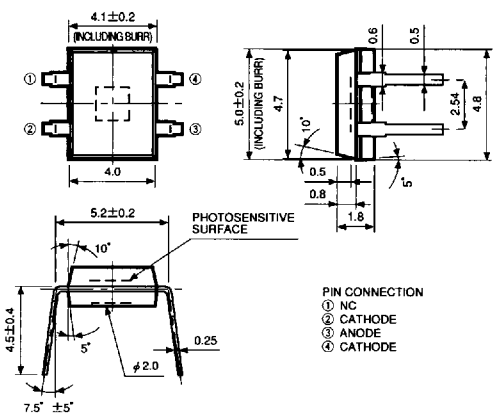

KSPDA0065EA

47 S5573

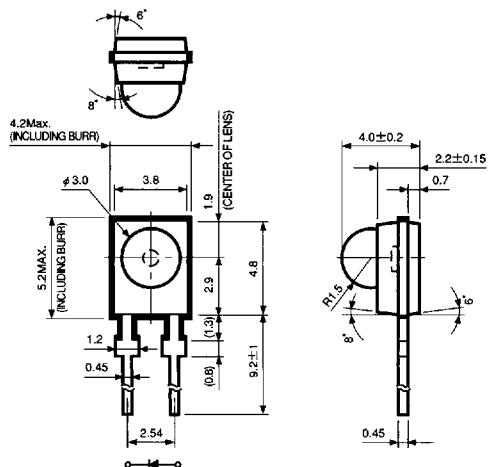

KPINA0032EA

48 S2973

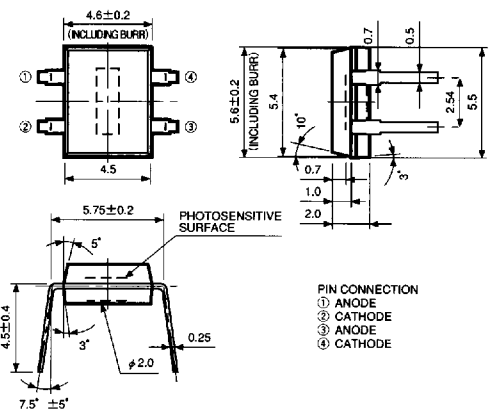

KSPDA0066EA

* The lead intervals shown in the dimensional outlines are center-to-center dimensions at the root of the leads. Dimensions are typical values unless otherwise specified. The values in parentheses are reference values.