

TOSHIBA PHOTO DARLINGTON TRANSISTOR SILICON NPN EPITAXIAL PLANAR

TPS607A

PHOTO DARLINGTON TRANSISTOR FOR PHOTO INTERRUPTER

Unit in mm

PHOTOELECTRIC COUNTER

POSITION DETECTION

AUTOMATIC CONTROL UNIT

- High sensitivity : $I_L = 2\text{mA}$ (TYP.)
- The same external shape as the infrared LED TLN107A, and is best suited for combination with TLN107A as a photo interrupter.
- Maximum distance when used as a photo sensor :
 TLN107A at DC drive $\approx 40\text{mm}$ When
 TPS607A $I_L \approx 500\mu\text{A}$

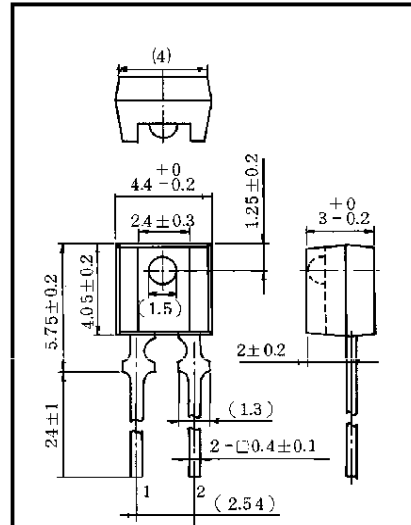

() : REFERENCE VALUE

MAXIMUM RATINGS ($T_a = 25^\circ\text{C}$)

CHARACTERISTIC	SYMBOL	RATING	UNIT
Collector-Emitter Voltage	V_{CEO}	30	V
Emitter-Collector Voltage	V_{ECO}	5	V
Collector Current	I_C	50	mA
Collector Power Dissipation	P_C	75	mW
Collector Power Dissipation Derating ($T_a > 25^\circ\text{C}$)	$\Delta P_C / ^\circ\text{C}$	-1	mW / $^\circ\text{C}$
Operating Temperature Range	T_{opr}	-25~85	$^\circ\text{C}$
Storage Temperature Range	T_{stg}	-40~100	$^\circ\text{C}$

JEDEC	—
EIAJ	—
TOSHIBA	0-4B1

Weight : 0.16g (TYP.)

PIN CONNECTION

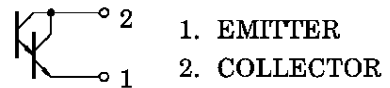

OPTO-ELECTRICAL CHARACTERISTICS ($T_a = 25^\circ\text{C}$)

CHARACTERISTIC	SYMBOL	TEST CONDITION	MIN.	TYP.	MAX.	UNIT
Dark Current	$I_D (I_{CEO})$	$V_{CE} = 16\text{V}, E = 0$	—	0.03	0.25	μA
Light Current	I_L (Note 1)	$V_{CE} = 3\text{V}, E = 0.1\text{mW}/\text{cm}^2$ (Note 2)	0.6	2	—	mA
Collector-Emitter Saturation Voltage	$V_{CE}(\text{sat})$	$V_{CE} = 0.3\text{mA}, E = 0.1\text{mW}/\text{cm}^2$ (Note 2)	—	0.9	1.2	V
Switching Time	Rise Time	$V_{CC} = 5\text{V}, I_C = 10\text{mA}$ $R_L = 100\Omega$	—	200	—	μs
	Fall Time		—	150	—	
Peak Sensitivity Wavelength	λ_p	—	—	720	—	nm
Half Value Angle	$\theta_{\frac{1}{2}}$	—	—	± 15	—	$^\circ$

Note 1. I_L Classification A : 0.6~3.6mA, B : 2.5~15mA, C : 5mA or more.

2. Color temperature = 2870°K Standard Tungsten Lamp.

961001EAA2

● TOSHIBA is continually working to improve the quality and the reliability of its products. Nevertheless, semiconductor devices in general can malfunction or fail due to their inherent electrical sensitivity and vulnerability to physical stress. It is the responsibility of the buyer, when utilizing TOSHIBA products, to observe standards of safety, and to avoid situations in which a malfunction or failure of a TOSHIBA product could cause loss of human life, bodily injury or damage to property. In developing your designs, please ensure that TOSHIBA products are used within specified operating ranges as set forth in the most recent products specifications. Also, please keep in mind the precautions and conditions set forth in the TOSHIBA Semiconductor Reliability Handbook.

RECOMMENDED OPERATING CONDITIONS

CHARACTERISTIC	SYMBOL	MIN.	TYP.	MAX.	UNIT
Supply Voltage	V _{CC}	—	5	16	V
Operating Temperature	T _{opr}	-25	—	75	°C

PRECAUTION

1. Soldering temperature : 260°C MAX.
Soldering time : 5s MAX.
(Soldering portion of lead : above 2mm from the body of the device)
2. If the lead is formed, the lead should be formed at a distance of 2mm from the body of the device.
Soldering shall be performed after lead forming.

961001EAA2'

- The information contained herein is presented only as a guide for the applications of our products. No responsibility is assumed by TOSHIBA CORPORATION for any infringements of intellectual property or other rights of the third parties which may result from its use. No license is granted by implication or otherwise under any intellectual property or other rights of TOSHIBA CORPORATION or others.
- The information contained herein is subject to change without notice.

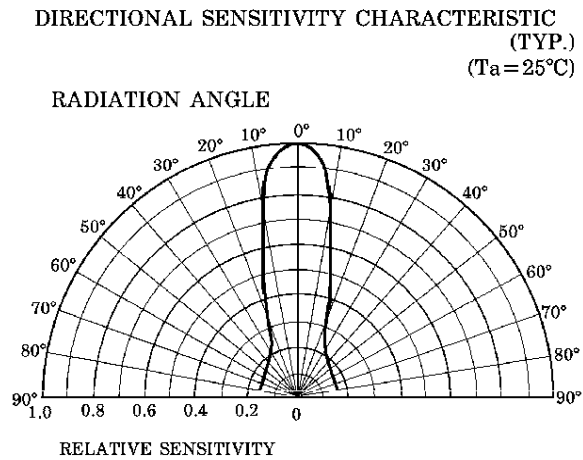
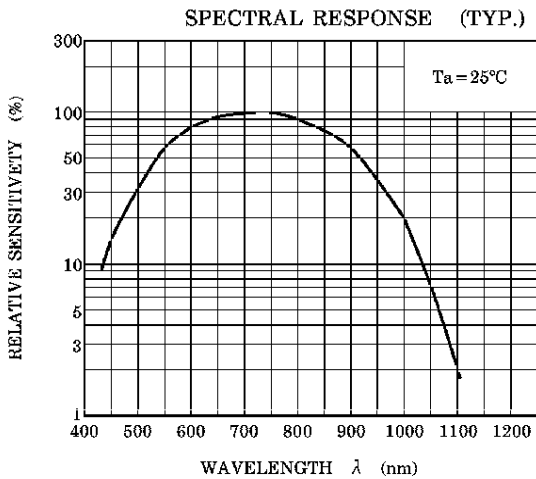
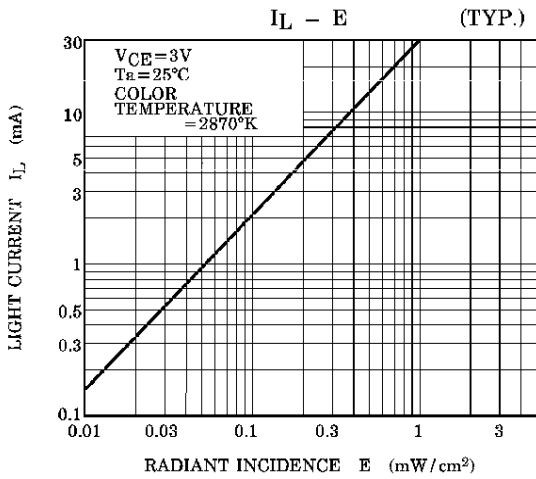
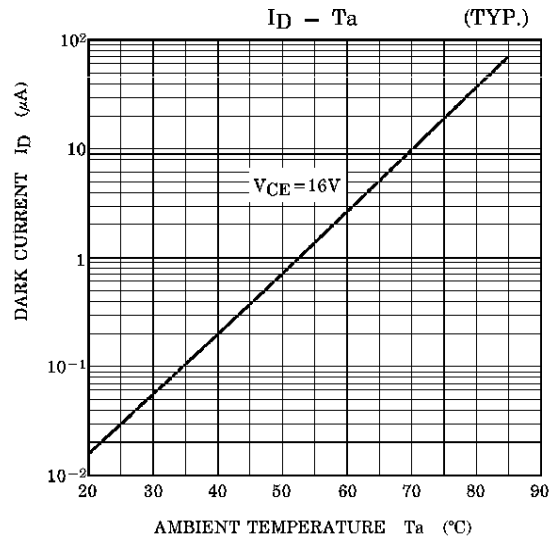
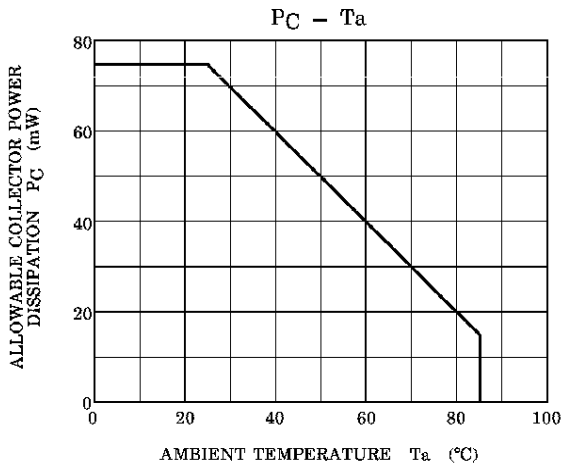

SWITCHING CHARACTERISTICS
(NON SATURATED OPERATION) (TYP.)

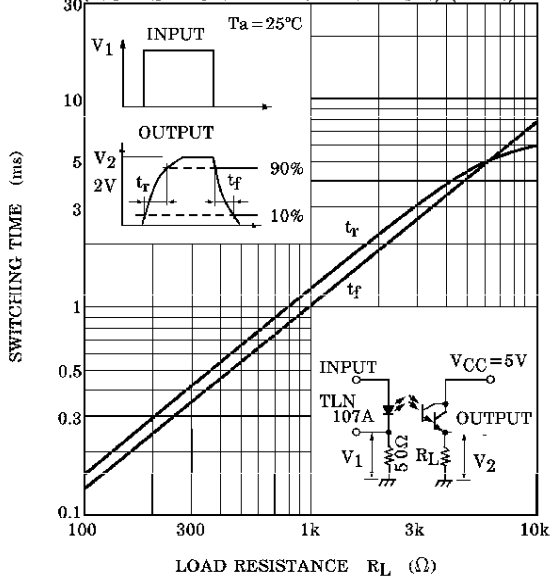

SWITCHING CHARACTERISTICS
(SATURATED OPERATION) (TYP.)

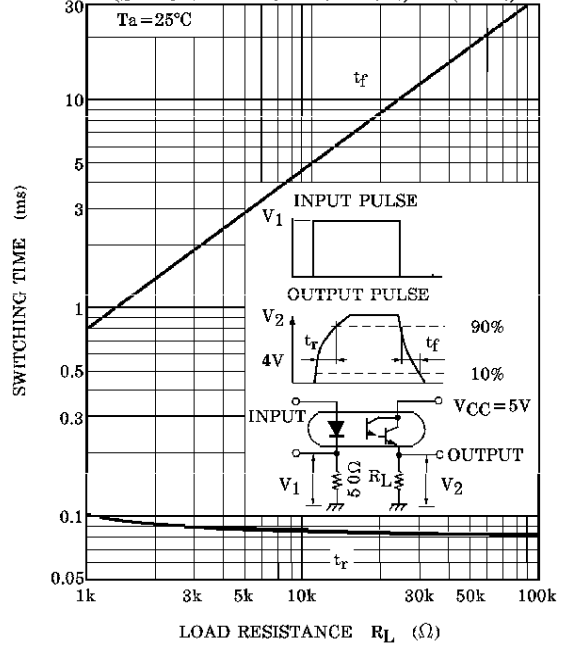

RELATIVE $I_L - T_a$ (TYP.)

