CMOS Extended Temperature Range 5 x 7 Alphanumeric Displays

Technical Data

HCMS-201X Series HCMS-231X HCMS-235X Series

Features

- **On-Board Low Power CMOS IC**
Integrated Shift Register with Constant Current LED Drivers
- **Wide Operating Temperature Range**
-55°C to +100°C
- **Compact Glass Ceramic 4 Character Package**
HCMS-201X Series X-Stackable
HCMS-231X/-235X Series X-Y Stackable
- **HCMS-235X Series are Sunlight Viewable**
- **Five Colors**
Standard Red
High Efficiency Red
Orange
Yellow
High Performance Green
- **5 x 7 LED Matrix Displays Full ASCII Set**
- **Two Character Heights**
3.8 mm (0.15 inch)
5.0 mm (0.20 inch)
- **Wide Viewing Angle**
X Axis = $\pm 50^\circ$
Y Axis = $\pm 65^\circ$
- **Long Viewing Distance**
HCMS-201X Series to 2.6 Meters (8.6 Feet)
HCMS-231X/-235X Series to 3.5 Meters (11.5 Feet)
- **Categorized for Luminous Intensity**
- **HCMS-2011/2013
HCMS-2311/-2313/-2314
HCMS-2351/-2353/-2354**
Useable in Night Vision Lighting Applications
- **HCMS-2011/-2013,
HCMS-2311/-2313 and
HCMS-2351/-2353:**
Categorized for Color

Typical Applications

- **Avionics**
- **Communications Systems**
- **Radar Systems**
- **Fire Control Systems**

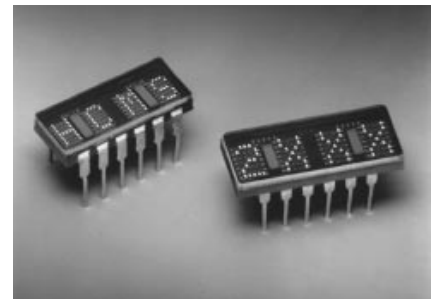

Description

The HCMS-201X, HCMS-231X and the sunlight viewable HCMS-235X series are 5 x 7 LED four character displays contained in 12 pin dual-in-line packages designed for displaying alphanumeric information. The character height for the HCMS-201X series displays is 3.8 mm (0.15 inch), and for the HCMS-231X and HCMS-235X series displays the character height is 5.0 mm (0.20 inch). The HCMS-201X series displays are available in four LED colors: standard red, high efficiency red, yellow and high performance green. The HCMS-231X series are available in all

ESD WARNING: STANDARD CMOS HANDLING PRECAUTIONS SHOULD BE OBSERVED.

five LED colors. The HCMS-235X series displays are available in four LED colors: high efficiency red, orange, yellow and high performance green. The HCMS-201X series displays are end stackable. The HCMS-231X and HCMS-235X series displays are end/row stackable.

These displays are designed with on-board CMOS integrated circuits for use in applications

where conservation of power is important. The two CMOS ICs form an on-board 28-bit serial-in-parallel-out shift register with constant current output LED row drivers. Decoded column data is clocked into the on-board shift register for each refresh cycle. Full character display is achieved with external column strobing.

Compatibility with HDSP-201X/-231X/-235X TTL IC Series Displays

The HCMS-201X, HCMS-231X and HCMS-235X CMOS IC displays are “drop-in” replacements for the equivalent HDSP-201X, HDSP-231X and HDSP-235X TTL IC displays. The 12 pin glass/ceramic package configuration, four digit character matrix and pin functions are identical.

Display Selection Table

Part Number	Character Size	LED Color
HCMS-2010	3.8 mm (0.15 inch)	Standard Red
HCMS-2011	3.8 mm (0.15 inch)	Yellow
HCMS-2012	3.8 mm (0.15 inch)	High-Efficiency Red
HCMS-2013	3.8 mm (0.15 inch)	High-Performance Green
HCMS-2310	5.0 mm (0.20 inch)	Standard Red
HCMS-2311	5.0 mm (0.20 inch)	Yellow
HCMS-2312	5.0 mm (0.20 inch)	High-Efficiency Red
HCMS-2313	5.0 mm (0.20 inch)	High-Performance Green
HCMS-2314	5.0 mm (0.20 inch)	Orange
Sunlight Viewable Displays		
HCMS-2351	5.0 mm (0.20 inch)	Yellow
HCMS-2352	5.0 mm (0.20 inch)	High-Efficiency Red
HCMS-2353	5.0 mm (0.20 inch)	High-Performance Green
HCMS-2354	5.0 mm (0.20 inch)	Orange

Package Dimensions

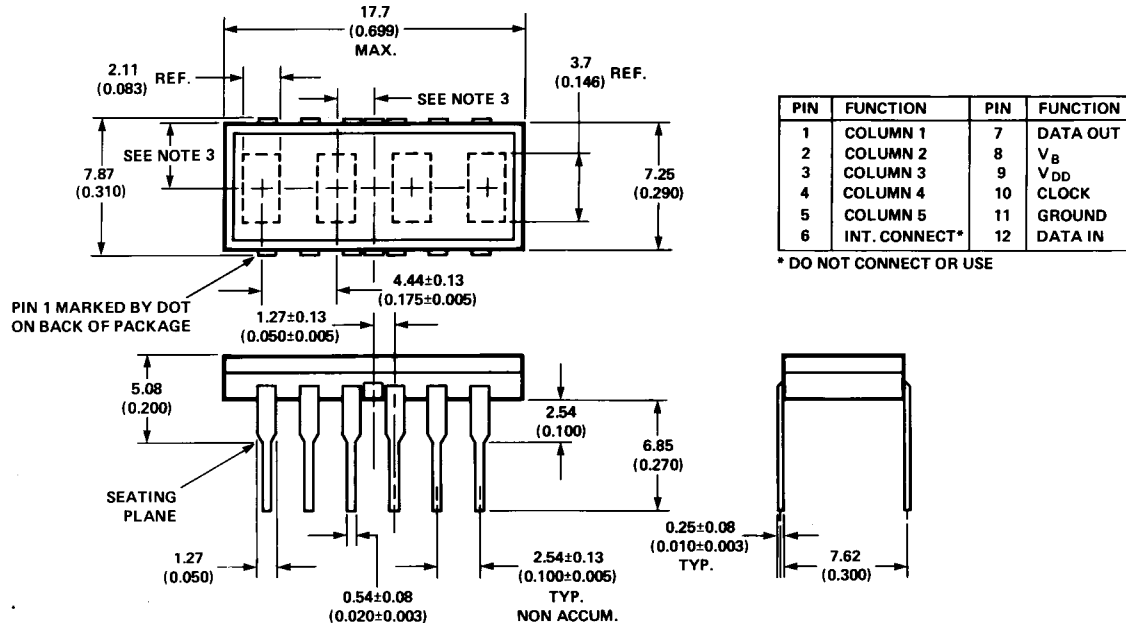

HCMS-201X Series

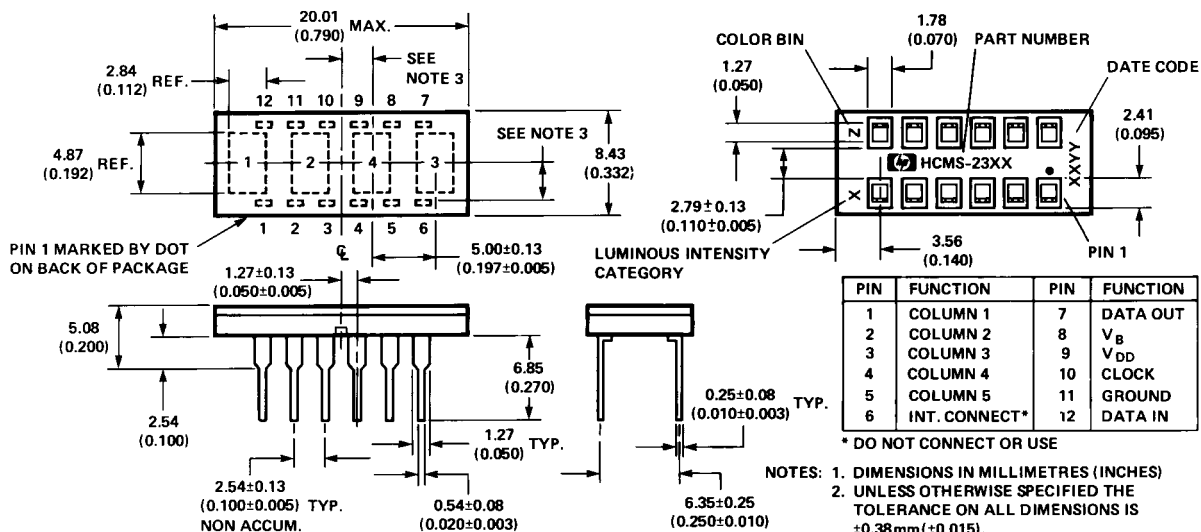

HCMS-231X/-235X Series

Absolute Maximum Ratings

Supply Voltage V_{DD} to Ground	-0.3 V to 7.0 V
Data Input, Data Output, V_B	-0.3 V to V_{DD}
Column Input Voltage, V_{COL}	-0.3 V to V_{DD}
Free Air Operating Temperature Range, T_A	-55°C to +100°C
Storage Temperature Range, T_S	-65°C to +125°C
HCMS-2310/-2311/-2312/-2314	
HCMS-2351/-2352/-2354	
Storage Temperature Range, T_S	-55°C to +100°C
HCMS-2010/-2011/-2012/-2013	
HCMS-2313	
HCMS-2353	
Maximum Allowable Package Power Dissipation, P_D [1,2]	
HCMS-2010/-2011/-2012/-2013 at $T_A = 83^\circ\text{C}$	0.79 Watts
HCMS-2310/-2311/-2312/-2313/-2314 at $T_A = 88^\circ\text{C}$	0.92 Watts
HCMS-2351/-2352/-2353/-2354 at $T_A = 71^\circ\text{C}$	1.31 Watts
Maximum Solder Temperature	
1.59 mm (0.063") Below Seating Plane, $t \leq 5$ sec	260°C
ESD Protection @ 1.5 k Ω , 100 pf	$V_Z = 4$ kV (each pin)

Notes:

- Maximum allowable power dissipation is derived from $V_{DD} = 5.25$ V, $V_B = 2.4$ V, $V_{COL} = 3.5$ V, 20 LEDs ON per character, 20% DF.
 - The power dissipation for these displays should be derated as follows:
 - HCMS-201X series derate above 83°C at 17 mW/°C, $R_{\theta_{JA}} = 60^\circ\text{C/W}$
 - HCMS-231X series derate above 88°C at 22 mW/°C, $R_{\theta_{JA}} = 45^\circ\text{C/W}$
 - HCMS-235X series derate above 71°C at 23 mW/°C, $R_{\theta_{JA}} = 45^\circ\text{C/W}$.
- Deratings based on $R_{\theta_{PC-A}} = 35^\circ\text{C/W}$ per display for printed circuit board assembly.
See Figure 1 for power derating based on lower $R_{\theta_{JA}}$ values.

Recommended Operating Conditions

Over Operating Temperature Range (-55°C to +100°C)

Parameter	Symbol	Min.	Typ.	Max.	Units
Supply Voltage	V_{DD}	4.75	5.00	5.25	V
Data Out Current, Low State	I_{OL}			1.6	mA
Data Out Current, High State	I_{OH}			-0.5	mA
Column Input Voltage	V_{COL}	2.75	3.0	3.5	V
Setup Time	t_{SETUP}	10			ns
Hold Time	t_{HOLD}	25			ns
Clock Pulse Width High	$t_{WH(CLOCK)}$	50			ns
Clock Pulse Width Low	$t_{WL(CLOCK)}$	50			ns
Clock High to Low Transition	t_{THL}			200	ns
Clock Frequency	f_{CLOCK}			5	MHz

**Electrical Characteristics
over Operating Temperature Range (-55°C to +100°C)**

Parameter	Symbol	Test Conditions	Min.	Typ.*	Max.	Units
Supply Current, Dynamic ^[1]	I _{DDD}	f _{CLOCK} = 5 MHz		6.2	7.8	mA
Supply Current, Static ^[2]	I _{DDSoFF} I _{DDSoN}	V _B = 0.4 V V _B = 2.4 V		1.8 2.2	2.6 6.0	mA
Column Input Current	I _{COL}	V _B = 0.4 V			10	μA
HCMS-2010/-2011/-2012/-2013		V _B = 2.4 V		310	384	mA
HCMS-2310/-2311/-2312/-2313/-2314		V _B = 2.4 V		360	451	mA
HCMS-2351/-2352/-2353/-2354		V _B = 2.4 V		500	650	mA
Input Logic High Data, V _B , Clock	V _{IH}	V _{DD} = 4.75 V	2.0			V
Input Logic Low Data, V _B , Clock	V _{IL}	V _{DD} = 5.25 V			0.8	V
Input Current Data, Clock V _B	I _I	V _{DD} = 5.25 V 0 ≤ V _I ≤ 5.25 V 0 ≤ V _B ≤ 5.25 V	-10 -40		+10 0	μA
Data Out Voltage	V _{OH}	V _{DD} = 4.75 V I _{OH} = -0.5 mA I _{COL} = 0 mA	2.4	4.2		V
	V _{OL}	V _{DD} = 5.25 V I _{OL} = 1.6 mA I _{COL} = 0 mA		0.2	0.4	V
Power Dissipation Per Package ^[3] HCMS-2010/-2011/-2012/-2013 HCMS-2310/-2311/-2312/-2313/-2314 HCMS-2351/-2352/-2353/-2354	P _D	V _{DD} = 5.0 V V _{COL} = 3.5 V 17.5% DF V _B = 2.4 V 15 LEDs ON per Character		414 481 668		mW
Thermal Resistance IC Junction-to-Pin ^[4] HCMS-2010/-2011/-2012/-2013 HCMS-2310/-2311/-2312/-2313/-2314 HCMS-2351/-2352/-2353/-2354	R _{θJ-PIN}			25 10 10		°C/W
Leak Rate					5x10 ⁻⁸	cc/sec

*All typical values specified at V_{DD} = 5.0V and T_A = 25°C.

Notes:

1. I_{DD} Dynamic is the IC current while clocking column data through the on-board shift register at a clock frequency of 5MHz, the display is not illuminated.
2. I_{DD} Static is the IC current after column data is loaded and not being clocked through the on-board shift register.
3. Four characters are illuminated with a typical ASCII character composed of 15 dots per character.
4. IC junction temperature T_J(IC) = (P_D)(R_{θJ-PIN} + R_{θPC-A}) + T_A.

Optical Characteristics at $T_A = 25^\circ\text{C}$

Standard Red HCMS-2010/-2310

Description	Symbol	Test Condition	Min.	Typ.	Max.	Units
Peak Luminous Intensity per LED ^[5,9] HCMS-2010 HCMS-2310 (Character Average)	I_{VPEAK}	$V_{DD} = 5.0\text{ V}$ $V_{COL} = 3.5\text{ V}$ $V_B = 2.4\text{ V}$ $T_i = 25^\circ\text{C}^{[7]}$	105 220	200 370		μcd
Dominant Wavelength ^[8]	λ_d			639		nm
Peak Wavelength	λ_{PEAK}			655		nm

Yellow HCMS-2011/-2311/-2351

Description	Symbol	Test Condition	Min.	Typ.	Max.	Units
Peak Luminous Intensity per LED ^[5,9] (Character Average) HCMS-2011 HCMS-2311 HCMS-2351	I_{VPEAK}	$V_{DD} = 5.0\text{ V}$ $V_{COL} = 3.5\text{ V}$ $V_B = 2.4\text{ V}$ $T_i = 25^\circ\text{C}^{[7]}$	400 650 2400	750 1140 3400		μcd
Dominant Wavelength ^[6,8]	λ_d			585		nm
Peak Wavelength	λ_{PEAK}			583		nm

High Efficiency Red HCMS-2012/-2312/-2352

Description	Symbol	Test Condition	Min.	Typ.	Max.	Units
Peak Luminous Intensity per LED ^[5,9] (Character Average) HCMS-2012 HCMS-2312 HCMS-2352	I_{VPEAK}	$V_{DD} = 5.0\text{ V}$ $V_{COL} = 3.5\text{ V}$ $V_B = 2.4\text{ V}$ $T_i = 25^\circ\text{C}^{[7]}$	400 650 1920	1430 1430 2850		μcd
Dominant Wavelength ^[8]	λ_d			625		nm
Peak Wavelength	λ_{PEAK}			635		nm

High Performance Green HCMS-2013/-2313/-2353

Description	Symbol	Test Condition	Min.	Typ.	Max.	Units
Peak Luminous Intensity per LED ^[5,9] (Character Average) HCMS-2013 HCMS-2313 HCMS-2353	I_{VPEAK}	$V_{DD} = 5.0\text{ V}$ $V_{COL} = 3.5\text{ V}$ $V_B = 2.4\text{ V}$ $T_i = 25^\circ\text{C}^{[7]}$	850 1280 2400	1550 2410 3000		μcd
Dominant Wavelength ^[6,8]	λ_d			574		nm
Peak Wavelength	λ_{PEAK}			568		nm

Orange HCMS-2314/-2354

Description	Symbol	Test Condition	Min.	Typ.	Max.	Units
Peak Luminous Intensity per LED ^[5,9] (Character Average) HCMS-2314 HCMS-2354	I_{VPEAK}	$V_{DD} = 5.0\text{ V}$ $V_{COL} = 3.5\text{ V}$ $V_B = 2.4\text{ V}$ $T_i = 25^\circ\text{C}$ ^[7]	650 1920	1430 2850		μcd
Dominant Wavelength ^[8]	λ_d			602		nm
Peak Wavelength	λ_{PEAK}			600		nm

All typical values specified at $V_{DD} = 5.0\text{ V}$ and $T_A = 25^\circ\text{C}$ unless otherwise noted.

Notes:

- These LED displays are categorized for luminous intensity, with the intensity category designated by a letter code on the back of the package.
- The HCMS-2011/-2311/-2351 and HCMS-2013/-2313/-2353 are categorized for color with the color category designated by a number on the back of the package.
- T_i refers to the initial case temperature of the display immediately prior to the light measurement.
- Dominant wavelength, λ_d , is derived from the CIE Chromaticity Diagram, and represents the single wavelength which defines the color of the device.
- The luminous sterance of the individual LED pixels may be calculated using the following equations:

$$L_v(\text{cd/m}^2) = I_v(\text{Candela}) * \text{DF} / \text{A}(\text{Metre})^2$$

$$L_v(\text{Footlamberts}) = \pi I_v(\text{Candela}) * \text{DF} / \text{A}(\text{Foot})^2$$
 Where: A = LED pixel area = $5.3 \times 10^{-8}\text{M}^2$ or $5.8 \times 10^{-7}\text{ft}^2$
 DF = LED on-time duty factor

Switching Characteristics, $T_A = -55^\circ\text{C}$ to $+100^\circ\text{C}$

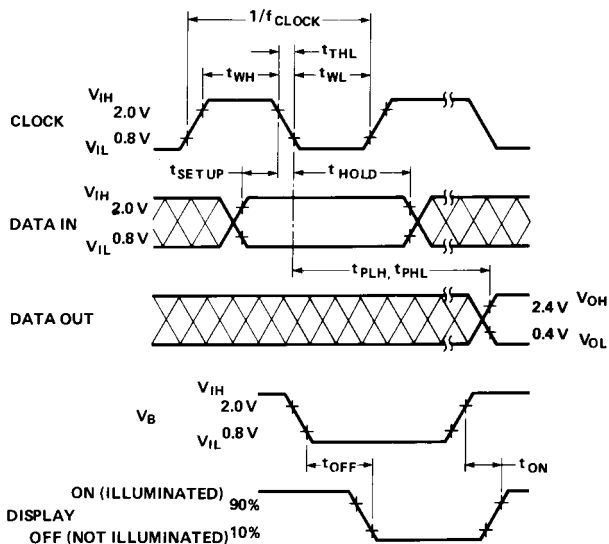

Parameter	Condition	Typ.	Max.	Units
f_{clock} CLOCK Rate			5	MHz
t_{PLH}, t_{PHL} Propagation Delay CLOCK to DATA OUT	$C_L = 15\text{ pF}$ $R_L = 2.4\text{ k}\Omega$		105	ns
t_{OFF} V_B (0.4 V) to Display OFF		4	5	μs
t_{ON} V_B (2.4 V) to Display ON		1	2	μs

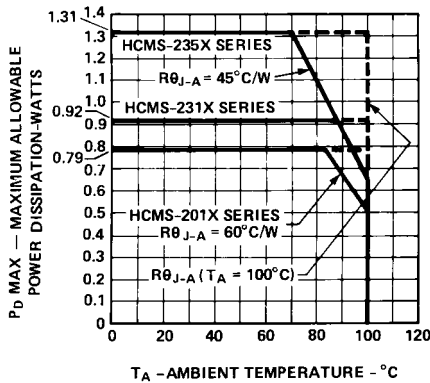

Figure 1. Maximum Allowable Power Dissipation vs Ambient Temperature as a Function of Thermal Resistance Junction-to-Ambient, $R_{\theta J-A}$. Derated Operation Assumes $R_{\theta P-C-A} = 35^{\circ}\text{C/W}$ per Display for Printed Circuit Board. T_j (IC) MAX = 130°C .

$R_{\theta J-A}$ ($T_A = 100^{\circ}\text{C}$)
 = 22°C/W for HCMS-235X Series
 = 32°C/W for HCMS-231X Series
 = 38°C/W for HCMS-201X Series.

Electrical Description

Each display device contains four 5×7 LED dot matrix characters and two CMOS integrated circuits, as shown in Figure 4. The two CMOS integrated circuits form an on-board 28 bit serial-in-parallel-out shift register that will accept standard TTL logic levels. The Data Input, pin 12, is connected to bit position 1 and the Data Output, pin 7, is connected to bit position 28. The shift register outputs control constant current sinking LED row drivers. The nominal current sink per LED driver is 11 mA for the HCMS-201X displays, 13 mA for the HCMS-231X displays and 18 mA for the HCMS-235X displays. A logic 1 stored in the shift register enables the corresponding LED row driver and a logic 0 stored in the shift register disables the corresponding LED row driver.

The electrical configuration of these CMOS IC alphanumeric displays allows for an effective

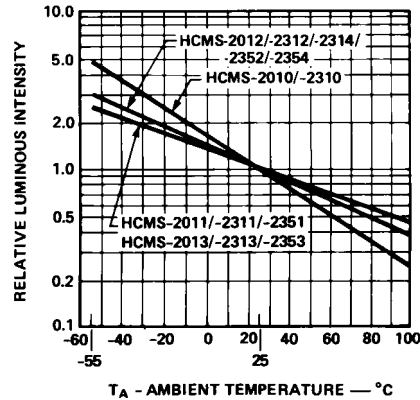

Figure 2. Relative Luminous Intensity vs Ambient Temperature.

interface to a display controller circuit that supplies decoded character information. The row data for a given column (one 7 bit byte per character) is loaded (bit serial) into the on-board 28 bit shift register with high to low transitions of the Clock input. To load decoded character information into the display, column data for character 4 is loaded first and the column data for character 1 is loaded last in the following manner. The 7 data bits for column 1, character 4, are loaded into the on-board shift register. Next, the 7 data bits for column 1, character 3, are loaded into the shift register, shifting the character 4 data over one character position. This process is repeated for the other two characters until all 28 bits of column data (four 7 bit bytes of character column data) are loaded into the on-board shift register. Then the column 1 input, V_{COL} pin 1, is energized to illuminate column 1 in all four characters. This process is repeated for columns

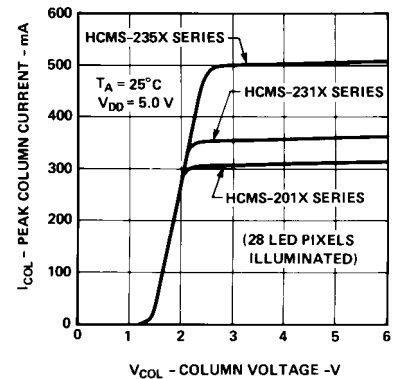

Figure 3. Peak Column Current vs Column Voltage.

2, 3, 4 and 5. All V_{COL} inputs should be at logic low to insure the display is off when loading data. The display will be blanked when the blanking input V_B , pin 8, is at logic low regardless of the outputs of the shift register or whether one of the V_{COL} inputs is energized.

Refer to Application Note 1016 for drive circuit information.

ESD Susceptibility

The HCMS-201X/-231X/-235X series displays have an ESD susceptibility ratings of CLASS 3 per DOD-STD-1686 and CLASS B per MIL-STD-883C. It is recommended that normal CMOS handling precautions be observed with these devices.

Soldering and Post Solder Cleaning

These displays may be soldered with a standard wave solder process using either an RMA flux and solvent cleaning or an OA flux and aqueous cleaning. For

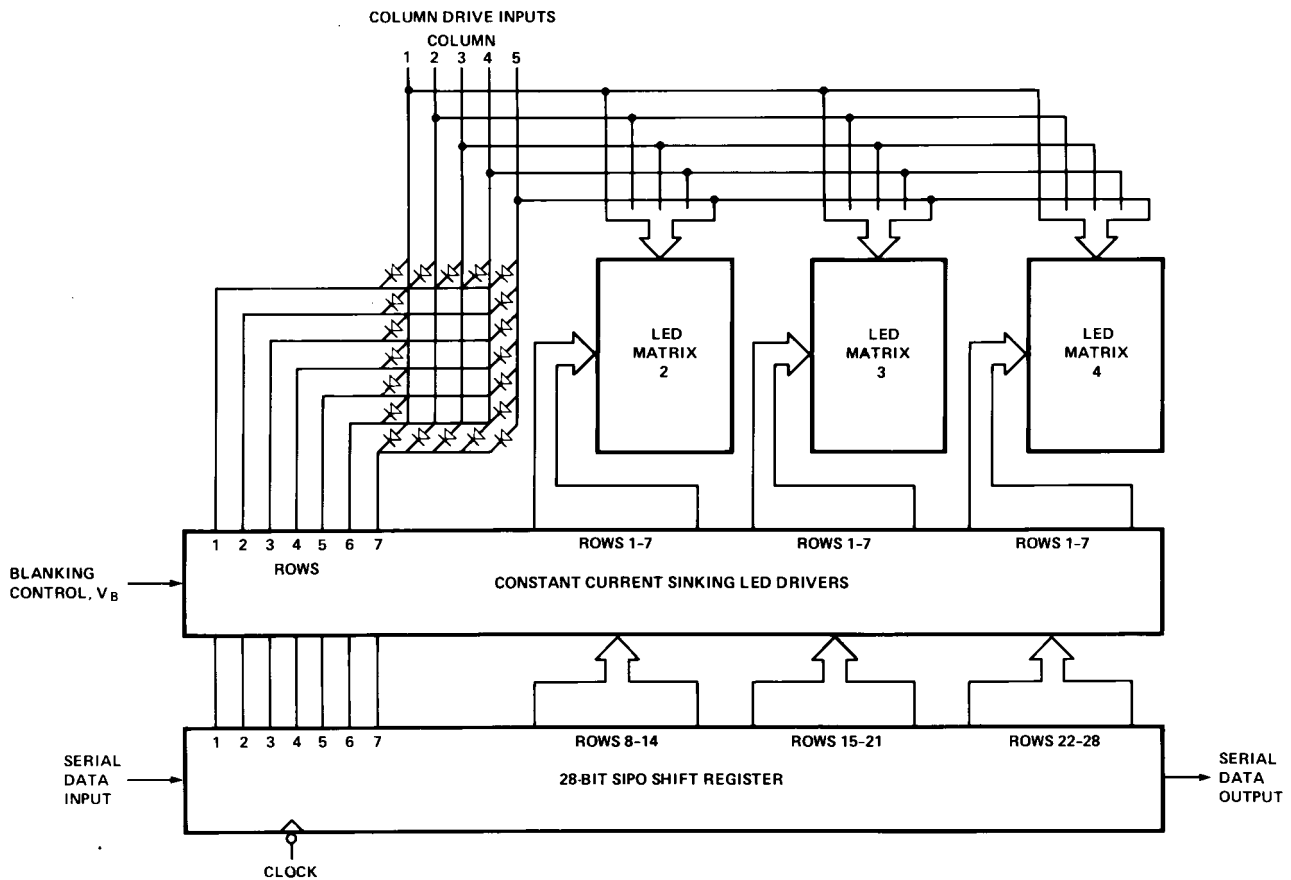

Figure 4. Block Diagram of an HCMS-2XXX Series LED Alphanumeric Display.

optimum soldering, the solder wave temperature should be 245°C and the dwell time for any display lead passing through the wave should be 1½ to 2 seconds. For more detailed information, refer to Application Note 1027 *Soldering LED Components*.

Contrast Enhancement

When used with the proper contrast enhancement filters, the HCMS-235X series displays are readable in sunlight and the HCMS-201X/231X series displays are readable in daylight ambients. Refer to Application Note 1029 *Luminous Contrast and Sunlight Readability of the HDSP-235X Series Alphanumeric Displays for Military*

Applications for information on contrast enhancement for sunlight and daylight ambients. Refer to Application Note 1015 *Contrast Enhancement Techniques for LED Displays* for information on contrast enhancement in moderate ambients.

Night Vision Lighting

When used with the proper NVG/DV filters, the HCMS-2311/-2351 and HCMS-2133/-2353 displays may be used in night vision lighting applications. The HCMS-2311/-2351 (yellow) displays are used as master caution and warning indicators. The HCMS-2313/-2353 (high performance green) displays are used for general instrumentation. For a

list of NVG/DV filters and a discussion on night vision lighting technology, refer to Application Note 1030 *LED Displays and Indicators and Night Vision Imaging System Lighting*.

Controller Circuits, Power Calculations and Display Dimming

Refer to Application Note 1016 *Using the HDSP-2000 Alphanumeric Display Family* for information on controller circuits to drive these displays, how to do power calculations and a technique for display dimming.