

# SN54ALS688, SN54ALS689, SN74ALS688, SN74ALS689 8-BIT IDENTITY COMPARATORS

D2661, JUNE 1982 — REVISED MAY 1986

- Compares Two Eight-Bit Words
- Choice of Totem-Pole or Open-Collector Outputs
- Package Options Include Plastic "Small Outline" Packages, Ceramic Chip Carriers, and Standard Plastic and Ceramic 300-mil DIPs
- Dependable Texas Instruments Quality and Reliability

| TYPE     | OUTPUT FUNCTION AND CONFIGURATION            |
|----------|--|
| 'ALS688† | $\overline{P} = \overline{Q}$ totem pole     |
| 'ALS689  | $\overline{P} = \overline{Q}$ open-collector |

†'ALS688 is identical to 'ALS521

## description

These identity comparators perform comparisons of two eight-bit binary or BCD words. The 'ALS688 and 'ALS689 provide  $\overline{P} = \overline{Q}$  outputs. The 'ALS688 has totem-pole outputs, while 'ALS689 has open-collector outputs.

The SN54ALS688 and SN54ALS689 are characterized for operation over the full military temperature range of  $-55^{\circ}\text{C}$  to  $125^{\circ}\text{C}$ . The SN74ALS688 and SN74ALS689 are characterized for operation from  $0^{\circ}\text{C}$  to  $70^{\circ}\text{C}$ .

FUNCTION TABLE

| INPUTS      |                          | OUTPUT<br>$\overline{P} = \overline{Q}$ |
|-------------|--------------------------|---|
| DATA<br>P,Q | ENABLE<br>$\overline{G}$ |   |
| $P = Q$     | L                        | L                                       |
| $P > Q$     | L                        | H                                       |
| $P < Q$     | L                        | H                                       |
| X           | H                        | H                                       |

## logic symbols†

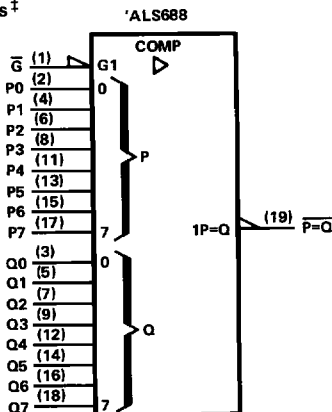

SN54ALS688, SN54ALS689 . . . J PACKAGE  
SN74ALS688, SN74ALS689 . . . DW OR N PACKAGE

(TOP VIEW)

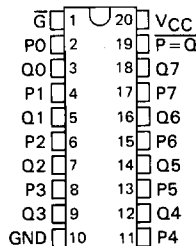

SN54ALS688, SN54ALS689 . . . FK PACKAGE

(TOP VIEW)

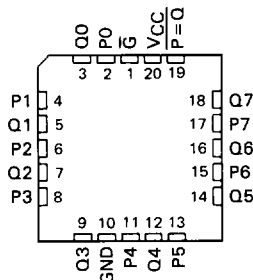

†These symbols are in accordance with ANSI/IEEE Std 91-1984 and IEC Publication 617-12.

PRODUCTION DATA documents contain information current as of publication date. Products conform to specifications per the terms of Texas Instruments standard warranty. Production processing does not necessarily include testing of all parameters.

TEXAS  
INSTRUMENTS

POST OFFICE BOX 655012 • DALLAS, TEXAS 75265

Copyright © 1982, Texas Instruments Incorporated

**SN54ALS688, SN54ALS689, SN74ALS688, SN74ALS689**  
**8-BIT IDENTITY COMPARATORS**

**2**

**ALS and AS Circuits**

logic diagram (positive logic)

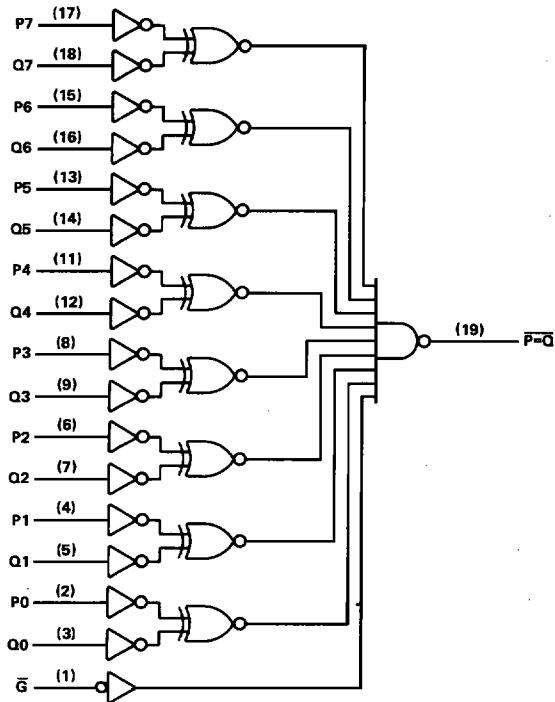

**absolute maximum ratings over operating free-air temperature range (unless otherwise noted)**

|   |                  |
|---|------------------|
| Supply voltage, $V_{CC}$ .....                                    | 7 V              |
| Input voltage: .....  | 7 V              |
| Off-state output voltage: 'ALS689 .....                           | 7 V              |
| Operating free-air temperature range: SN54ALS688, SN54AS689 ..... | -55 °C to 125 °C |
| SN74ALS688, SN74AS689 .....                                       | 0 °C to 70 °C    |
| Storage temperature range .....                                   | -65 °C to 150 °C |

# SN54ALS688, SN74ALS688

## 8-BIT IDENTITY COMPARATORS WITH TOTEM-POLE OUTPUTS

### recommended operating conditions

|                 |                                | SN54ALS688 |     |     | SN74ALS688 |     |     | UNIT |
|-----------------|--------------------------------|------------|-----|-----|------------|-----|-----|------|
|                 |                                | MIN        | NOM | MAX | MIN        | NOM | MAX |      |
| V <sub>CC</sub> | Supply voltage                 | 4.5        | 5   | 5.5 | 4.5        | 5   | 5.5 | V    |
| V <sub>IH</sub> | High-level input voltage       | 2          |     |     | 2          |     |     | V    |
| V <sub>IL</sub> | Low-level input voltage        |            |     |     | 0.7        |     |     | V    |
| I <sub>OH</sub> | High-level output current      |            |     |     | -1         |     |     | mA   |
| I <sub>OL</sub> | Low-level output current       |            |     |     | 24         |     |     | mA   |
| T <sub>A</sub>  | Operating free-air temperature | -55        |     |     | 125        |     |     | °C   |

### electrical characteristics over recommended operating free-air temperature range (unless otherwise noted)

| PARAMETER                   | TEST CONDITIONS   | SN54ALS688          |                  |     | SN74ALS688          |                  |     | UNIT |
|-----------------------------|---|---------------------|------------------|-----|---------------------|------------------|-----|------|
|                             |   | MIN                 | TYP <sup>†</sup> | MAX | MIN                 | TYP <sup>†</sup> | MAX |      |
| V <sub>IK</sub>             | V <sub>CC</sub> = 4.5 V, I <sub>I</sub> = -18 mA            | -1.5                |                  |     | -1.5                |                  |     | V    |
| V <sub>OH</sub>             | V <sub>CC</sub> = 4.5 V to 5.5 V, I <sub>OH</sub> = -0.4 mA | V <sub>CC</sub> - 2 |                  |     | V <sub>CC</sub> - 2 |                  |     | V    |
|                             | V <sub>CC</sub> = 4.5 V, I <sub>OH</sub> = -1 mA            | 2.4                 | 3.3              |     |                     |                  |     |      |
| V <sub>OL</sub>             | V <sub>CC</sub> = 4.5 V, I <sub>OH</sub> = -2.6 mA          |                     |                  |     | 2.4                 | 3.2              |     | V    |
|                             | V <sub>CC</sub> = 4.5 V, I <sub>OL</sub> = 12 mA            | 0.25                |                  | 0.4 | 0.25                |                  | 0.4 |      |
| I <sub>I</sub>              | V <sub>CC</sub> = 4.5 V, V <sub>I</sub> = 7 V               |                     |                  |     | 0.35                |                  | 0.5 | mA   |
|                             | V <sub>CC</sub> = 5.5 V, V <sub>I</sub> = 7 V               |                     |                  |     | 0.1                 |                  |     |      |
| I <sub>IH</sub>             | V <sub>CC</sub> = 5.5 V, V <sub>I</sub> = 2.7 V             | 20                  |                  |     | 20                  |                  |     | μA   |
| I <sub>IL</sub>             | V <sub>CC</sub> = 5.5 V, V <sub>I</sub> = 0.4 V             | -0.1                |                  |     | -0.1                |                  |     | mA   |
| I <sub>O</sub> <sup>‡</sup> | V <sub>CC</sub> = 5.5 V, V <sub>O</sub> = 2.25 V            | -30                 |                  |     | -112                |                  |     | mA   |
| I <sub>CC</sub>             | V <sub>CC</sub> = 5.5 V See Note 1                          | 12                  |                  |     | 19                  |                  |     | mA   |

<sup>†</sup>All typical values are at V<sub>CC</sub> = 5 V, T<sub>A</sub> = 25°C.

<sup>‡</sup>The output conditions have been chosen to produce a current that closely approximates one half of the true short-circuit output current, I<sub>OS</sub>.

NOTE 1: I<sub>CC</sub> is measured with G grounded, P and Q at 4.5 V.

### switching characteristics (see Note 2)

| PARAMETER        | FROM (INPUT) | TO (OUTPUT) | V <sub>CC</sub> = 4.5 V to 5.5 V,<br>C <sub>L</sub> = 50 pF,<br>R <sub>L</sub> = 500 Ω,<br>T <sub>A</sub> = MIN to MAX |     |            |     | UNIT |
|------------------|--------------|-------------|--|-----|------------|-----|------|
|                  |              |             | SN54ALS688   |     | SN74ALS688 |     |      |
|                  |              |             | MIN  | MAX | MIN        | MAX |      |
| t <sub>PLH</sub> | P            | P = Q       | 3  | 16  | 3          | 12  | ns   |
| t <sub>PHL</sub> |              |             | 5  | 25  | 5          | 20  |      |
| t <sub>PLH</sub> | Q            | P = Q       | 3  | 16  | 3          | 12  | ns   |
| t <sub>PHL</sub> |              |             | 5  | 25  | 5          | 20  |      |
| t <sub>PLH</sub> | Q̄           | P̄ = Q̄     | 3  | 15  | 3          | 12  | ns   |
| t <sub>PHL</sub> |              |             | 5  | 25  | 5          | 22  |      |

NOTE 2: Load circuit and voltage waveforms are shown in Section 1.

# SN54ALS689, SN74ALS689

## 8-BIT IDENTITY COMPARATORS WITH OPEN-COLLECTOR OUTPUTS

### recommended operating conditions

|          |                                | SN54ALS689 |     |     | SN74ALS689 |     |     | UNIT |
|----------|--------------------------------|------------|-----|-----|------------|-----|-----|------|
|          |                                | MIN        | NOM | MAX | MIN        | NOM | MAX |      |
| $V_{CC}$ | Supply voltage                 | 4.5        | 5   | 5.5 | 4.5        | 5   | 5.5 | V    |
| $V_{IH}$ | High-level input voltage       | 2          |     |     | 2          |     |     | V    |
| $V_{IL}$ | Low-level input voltage        |            |     |     | 0.7        |     |     | V    |
| $I_{OH}$ | High-level output current      |            |     |     | 5.5        |     |     | V    |
| $I_{OL}$ | Low-level output current       |            |     |     | 24         |     |     | mA   |
| $T_A$    | Operating free-air temperature | -55        |     |     | 125        |     |     | °C   |

2

ALS and AS Circuits

### electrical characteristics over recommended operating free-air temperature range (unless otherwise noted)

| PARAMETER | TEST CONDITIONS                                   | SN54ALS689 |      |     | SN74ALS689 |      |     | UNIT |
|-----------|---|------------|------|-----|------------|------|-----|------|
|           |   | MIN        | TYP† | MAX | MIN        | TYP† | MAX |      |
| $V_{IK}$  | $V_{CC} = 4.5\text{ V}$ , $I_I = -18\text{ mA}$   | -1.5       |      |     | -1.5       |      |     | V    |
| $I_{OH}$  | $V_{CC} = 5.5\text{ V}$ , $V_{OH} = 5.5\text{ V}$ | 0.1        |      |     | 0.1        |      |     | mA   |
| $V_{OL}$  | $V_{CC} = 4.5\text{ V}$ , $I_{OL} = 12\text{ mA}$ | 0.25       | 0.4  |     | 0.25       | 0.4  | V   |      |
|           | $V_{CC} = 4.5\text{ V}$ , $I_{OL} = 24\text{ mA}$ |            |      |     | 0.35       | 0.5  |     |      |
| $I_I$     | $V_{CC} = 5.5\text{ V}$ , $V_I = 7\text{ V}$      | 0.1        |      |     | 0.1        |      |     | mA   |
| $I_{IH}$  | $V_{CC} = 5.5\text{ V}$ , $V_I = 2.7\text{ V}$    | 20         |      |     | 20         |      |     | μA   |
| $I_{IL}$  | $V_{CC} = 5.5\text{ V}$ , $V_I = 0.4\text{ V}$    | -0.1       |      |     | -0.1       |      |     | mA   |
| $I_{CC}$  | $V_{CC} = 5.5\text{ V}$ , See Note 1              | 12         | 19   |     | 12         | 19   | mA  |      |

† All typical values are at  $V_{CC} = 5\text{ V}$ ,  $T_A = 25^\circ\text{C}$ .

NOTE 1:  $I_{CC}$  is measured with G grounded, P and Q at 4.5 V.

### switching characteristics (see Note 2)

| PARAMETER | FROM (INPUT)   | TO (OUTPUT)                   | $V_{CC} = 4.5\text{ V to }5.5\text{ V}$ ,<br>$C_L = 50\text{ pF}$ ,<br>$R_L = 680\ \Omega$ ,<br>$T_A = \text{MIN to MAX}$ |     |            |     | UNIT |
|-----------|----------------|-------------------------------|---|-----|------------|-----|------|
|           |                |                               | SN54ALS689  |     | SN74ALS689 |     |      |
|           |                |                               | MIN   | MAX | MIN        | MAX |      |
| $t_{PLH}$ | P              | $\overline{P} = \overline{Q}$ | 10  | 30  | 10         | 25  | ns   |
| $t_{PHL}$ |                |                               | 5   | 25  | 5          | 23  |      |
| $t_{PLH}$ | Q              | $\overline{P} = \overline{Q}$ | 10  | 30  | 10         | 25  | ns   |
| $t_{PHL}$ |                |                               | 5   | 25  | 5          | 23  |      |
| $t_{PLH}$ | $\overline{G}$ | $\overline{P} = \overline{Q}$ | 8   | 30  | 8          | 25  | ns   |
| $t_{PHL}$ |                |                               | 8   | 30  | 8          | 25  |      |

NOTE 2: Load circuit and voltage waveforms are shown in Section 1.