

# SPACE-PHY Dual MIL-STD-1553 Transceiver/Transformer Device



## Product Brief

Models: BU-67402F30HL, BU-67402F80HL



**+3.3V or +5V  
Operation**

SPACE-PHY, available in both 3.3V and 5V versions, is a completely integrated Rad Tolerant MIL-STD-1553 physical layer in a single package, including dual transceivers and transformers, and is designed to connect with IP incorporated in an FPGA or custom MIL-STD-1553 protocol ASIC.

### Key Features

- Dual-Redundant, Side-by-Side, MIL-STD-1553 Transceiver/Transformer Combo
- Compact Ceramic Flatpack Package
  - 1 in. x 1 in. x 0.25 in. (25.4 mm x 25.4 mm x 6.35 mm)
  - Operating Temperature: -55°C to +125°C
- Radiation Specifications
  - Total Dose: 100 krad (5V version), 300krads (3.3V version)
  - Latchup Immunity: >85 MeV-cm<sup>2</sup>/mg
  - Contact Factory for Radiation Reports and Test Conditions
- Dual Tap Secondaries
  - Secondaries' Center Taps Brought Out
- MIL-PRF-38534 Class H or Class K
- +3.3V or +5V Operation

### Benefits

- Compact Integrated Design Saves Space... Replaces Two Transceivers and Two Transformers
- Single Package Simplifies Layout and Improves Reliability (MTBF)
- Transformers and Transceivers, Trimmed and Tested as a Set, Provide Superior Margin for MIL-STD-1553 Compliance

### Applications

- Launch Vehicles
- Military Satellites
- Research Satellites
- International Space Station
- Commercial Telecommunication Satellite

#### Need a Custom Solution?

DDC can customize designs for all products, ranging from simple modifications of standard products to fully customized solutions for commercial, military, aerospace, and industrial applications.

## Quick Specs

POWER SUPPLY CURRENT		MIN	TYP	MAX
BU-67402F30HL-XXXX	idle	-	80mA	100mA
	25%	-	199mA	229mA
	50%	-	286mA	348mA
	100%	-	455mA	535mA
BU-67402F80HL-XXXX	idle	-	18mA	28mA
	25%	-	134mA	185mA
	50%	-	270mA	342mA
	100%	-	517mA	656mA

POWER DISSIPATION		MIN	TYP	MAX
BU-67402F30HL-XXXX	idle	-	0.40W	0.50W
	25%	-	0.66W	0.81W
	50%	-	0.75W	1.06W
	100%	-	0.92W	1.32W
BU-67402F80HL-XXXX	idle	-	0.059W	0.100W
	25%	-	0.158W	0.275W
	50%	-	0.257W	0.45W
	100%	-	0.455W	0.80W

For more information: [www.ddc-web.com/BU-67402F](http://www.ddc-web.com/BU-67402F)

# Mechanical Outlines

## Flat Package

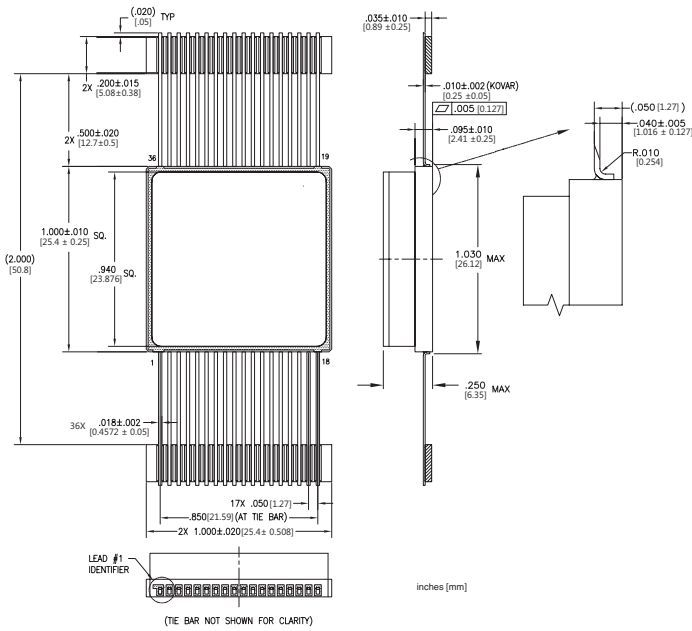

## Gull Wing Package

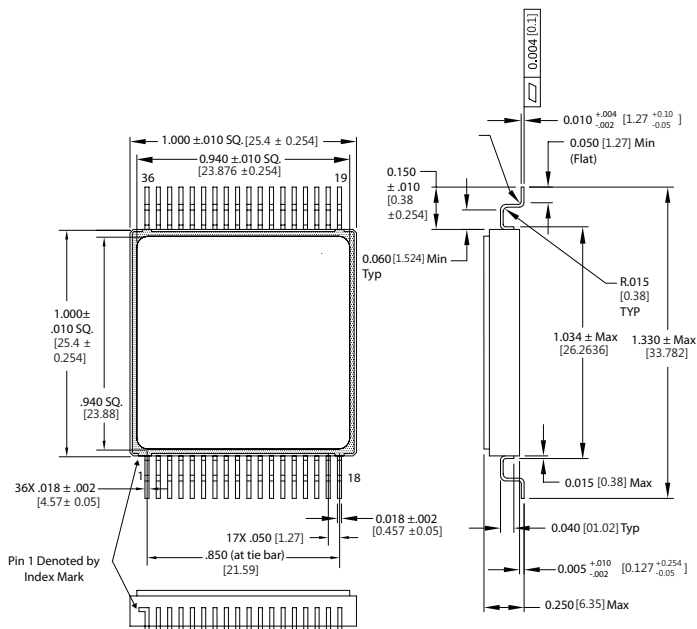

# Block Diagram

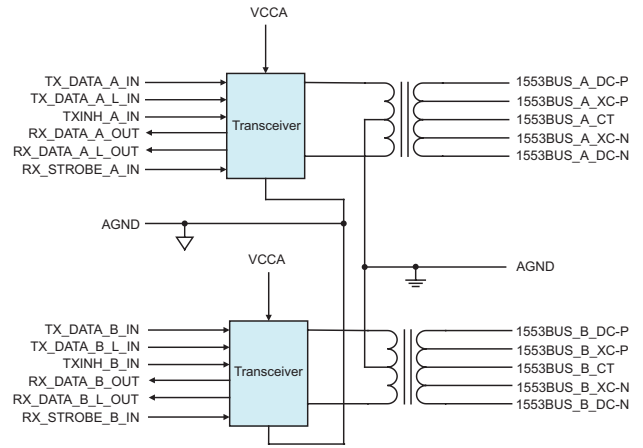

# Ordering Information

BU-67402F80HL-XXXX

### Supplemental Process Requirements:

- S = Pre-Cap Source Inspection
- L = 100% Pull Test
- Q = 100% Pull Test and Pre-Cap Source Inspection
- K = One Lot Data Code
- W = One Lot Data Code and Pre-Cap Source Inspection
- Y = One Lot Date Code and 100% Pull Test
- Z = One Lot Date Code, Pre-Cap Source Inspection and 100% Pull Test
- Blank = None of the Above

### Other Criteria:

- 0 = No X-Ray
- 1 = X-Ray

### Process Requirements:

- 0 = Standard DDC Processing, no Burn-In
- 1 = MIL-PRF-38534 Compliant (note 1)
- 3 = MIL-PRF-38534 Compliant with PIND Testing (note 1)
- 4 = MIL-PRF-38534 Compliant with Solder Dip (notes 1, 2)
- 5 = MIL-PRF-38534 Compliant with PIND Testing and Solder Dip (notes 1, 2)
- 9 = Standard DDC Processing with Solder Dip, no Burn-In

### Temperature Grade/Data Requirements

- 1 = -55°C to +125°C
- 3 = 0°C to +70°C
- 4 = -55°C to +125°C with Variables Test Data

### MIL-PRF-38534 Compliance:

- H = Class H
- K = Class K (note 3)

### Operating Voltage:

- 3 = +5V
- 8 = +3.3V

### Package:

- F = Flat Pack
- G = Gull Leads (note 4)

### Notes:

1. Standard processing on this device includes 320 hours of burn-in.
2. These products contain tin-lead solder finish as applicable to solder dip requirements.
3. MIL-PRF-38534 Class K requires PIND testing, X-Ray, and 100% Pull Test (-X31X or -X51X with L, Q, Y, or Z as the last digit).
4. Gull wing package requires solder dip (-X4XX, -X5XX, or -X9XX).
5. MIL-PRF-38534 devices are compliant to SMD 5962-13225.



The information in this Flyer is believed to be accurate; however, no responsibility is assumed by Data Device Corporation for its use, and no license or rights are granted by implication or otherwise in connection therewith. Specifications are subject to change without notice.

### For ordering assistance and technical support,

E-Mail: [service@ddc-web.com](mailto:service@ddc-web.com)

Visit: [ddc-web.com](http://ddc-web.com)

Data Device Corporation

Call: HQ, N.Y., U.S.A.

1-800-DDC-5757 | (631) 567-5600

UK +44-(0)1635-811140

France +33-(0)1-41-16-3424

Germany +49-(0)89-1500-12-11

Japan +81-(0)3-3814-7688

Asia +65-6489-4801

India +91 080 301 10 200

