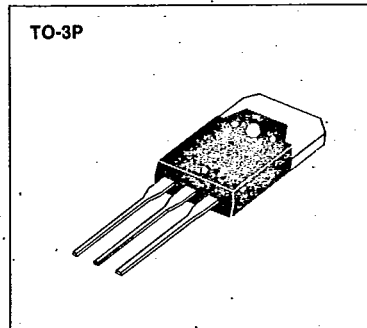
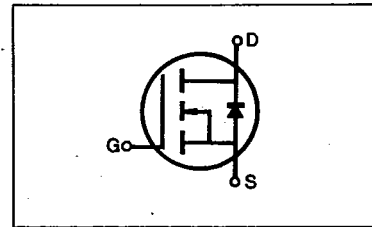

IRFP220/221/222/223**N-CHANNEL
POWER MOSFETS****FEATURES**

- Low $R_{DS(on)}$
- Improved inductive ruggedness
- Fast switching times
- Rugged polysilicon gate cell structure
- Low input capacitance
- Extended safe operating area
- Improved high temperature reliability
- TO-3P package

**PRODUCT SUMMARY**

Part Number	V_{DS}	$R_{DS(on)}$	I_D
IRFP220	200V	0.8 Ω	5.0A
IRFP221	150V	0.8 Ω	5.0A
IRFP222	200V	1.2 Ω	4.0A
IRFP223	150V	1.2 Ω	4.0A

**MAXIMUM RATINGS**

Characteristic	Symbol	IRFP220	IRFP221	IRFP222	IRFP223	Unit
Drain-Source Voltage (1)	V_{DSS}	200	150	200	150	Vdc
Drain-Gate Voltage ($R_{GS}=1.0M\Omega$) (1)	V_{DGR}	200	150	200	150	Vdc
Gate-Source Voltage	V_{GS}	± 20				Vdc
Continuous Drain Current $T_C=25^\circ C$	I_D	5.0	5.0	4.0	4.0	Adc
Continuous Drain Current $T_C=100^\circ C$	I_D	3.0	3.0	2.0	2.0	Adc
Drain Current—Pulsed (3)	I_{DM}	20	20	16	16	Adc
Gate Current—Pulsed	I_{GM}	± 1.5				Adc
Total Power Dissipation @ $T_C=25^\circ C$	P_D	40				Watts
Derate above $25^\circ C$		0.32				W/ $^\circ C$
Operating and Storage Junction Temperature Range	T_J, T_{stg}	-55 to 150				$^\circ C$
Maximum Lead Temp. for Soldering Purposes, 1/8" from case for 5 seconds	T_L	300				$^\circ C$

Notes: (1) $T_J=25^\circ C$ to $150^\circ C$ (2) Pulse test: Pulse width $\leq 300\mu s$, Duty Cycle $\leq 2\%$

(3) Repetitive rating: Pulse width limited by max. junction temperature

98 DE 7964142 0005170 6

IRFP220/221/222/223

N-CHANNEL
POWER MOSFETSELECTRICAL CHARACTERISTICS (T_C=25°C unless otherwise specified)

Characteristic	Symbol	Type	Min	Typ	Max	Units	Test Conditions
Drain-Source Breakdown Voltage	BV _{DSS}	IRFP220	200	—	—	V	V _{GS} =0V, I _D =250μA
		IRFP222	—	—	—	—	
		IRFP221	150	—	—	V	
		IRFP223	—	—	—	—	
Gate Threshold Voltage	V _{GS(th)}	ALL	2.0	—	4.0	V	V _{DS} =V _{GS} , I _D =250μA
Gate-Source Leakage Forward	I _{GSS}	ALL	—	—	100	nA	V _{GS} =20V
Gate-Source Leakage Reverse	I _{GSS}	ALL	—	—	-100	nA	V _{GS} =-20V
Zero Gate Voltage Drain Current	I _{DSS}	ALL	—	—	250	μA	V _{DS} =Max. Rating, V _{GS} =0V
			—	—	1000	μA	V _{DS} =Max. Rating×0.8, V _{GS} =0V, T _C =125°C
On-State Drain-Source Current (2)	I _{D(on)}	IRFP220	5.0	—	—	A	V _{DS} >I _{D(on)} ×R _{DS(on)} max., V _{GS} =10V
		IRFP221	—	—	—	—	
		IRFP222	4.0	—	—	A	
		IRFP223	—	—	—	—	
Static Drain-Source On-State Resistance (2)	R _{DS(on)}	IRFP220	—	0.4	0.8	Ω	V _{GS} =10V, I _D =2.5A
		IRFP221	—	—	—	—	
		IRFP222	—	0.8	1.2	Ω	
		IRFP223	—	—	—	—	
Forward Transconductance (2)	g _{fs}	ALL	1.3	2.8	—	Ω	V _{DS} >I _{D(on)} ×R _{DS(on)} max., I _D =2.5A
Input Capacitance	C _{iss}	ALL	—	450	600	pF	V _{GS} =0V, V _{DS} =25V, f=1.0MHz
Output Capacitance	C _{oss}	ALL	—	150	300	pF	
Reverse Transfer Capacitance	C _{rss}	ALL	—	50	80	pF	
Turn-On Delay Time	t _{d(on)}	ALL	—	—	40	ns	V _{DD} =0.5BV _{DSS} , I _D =2.5A, Z _O =50Ω (MOSFET switching times are essentially independent of operating temperature)
Rise Time	T _r	ALL	—	—	60	ns	
Turn-Off Delay Time	t _{d(off)}	ALL	—	—	100	ns	
Fall Time	t _f	ALL	—	—	60	ns	
Total Gate Charge (Gate-Source Plus Gate-Drain)	Q _g	ALL	—	12.5	15	nC	V _{GS} =10V, I _D =6.0A, V _{DS} =0.8 Max. Rating (Gate charge is essentially independent of operating temperature.)
Gate-Source Charge	Q _{gs}	ALL	—	4.0	—	nC	
Gate-Drain ("Miller") Charge	Q _{gd}	ALL	—	8.5	—	nC	

THERMAL RESISTANCE

Junction-to-Case	R _{thJC}	ALL	—	—	3.12	K/W	
Case-to-Sink	R _{thCS}	ALL	—	0.1	—	K/W	Mounting surface flat, smooth, and greased
Junction-to-Ambient	R _{thJA}	ALL	—	—	80	K/W	Free Air Operation

Notes: (1) T_J=25°C to 150°C

(2) Pulse test: Pulse width≤300μs, Duty Cycle≤2%

(3) Repetitive rating: Pulse width limited by max. junction temperature

**N-CHANNEL
POWER MOSFETS**

IRFP220/221/222/223

SOURCE-DRAIN DIODE RATINGS AND CHARACTERISTICS

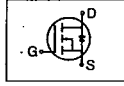
Characteristic	Symbol	Type	Min	Typ	Max	Units	Test Conditions
Continuous Source Current (Body Diode)	I _S	IRFP220	—	—	5.0	A	Modified MOSFET symbol showing the integral reverse P-N junction rectifier 
		IRFP221	—	—	5.0	A	
		IRFP222	—	—	4.0	A	
		IRFP223	—	—	4.0	A	
Pulse Source Current (Body Diode) (3)	I _{SM}	IRFP220	—	—	20	A	
		IRFP221	—	—	20	A	
		IRFP222 IRFP223	—	—	16	A	
Diode Forward Voltage (2)	V _{SD}	IRFP220	—	—	2.0	V	T _C =25°C, I _S =5.0A, V _{GS} =0V
		IRFP221	—	—	2.0	V	T _C =25°C, I _S =5.0A, V _{GS} =0V
		IRFP222 IRFP223	—	—	1.8	V	T _C =25°C, I _S =4.0A, V _{GS} =0V
Reverse Recovery Time	t _{rr}	ALL	—	350	—	ns	T _J =150°C, I _F =5.0A, dI _F /dt=100A/μs

Notes: (1) T_J=25°C to 150°C (2) Pulse test: Pulse width<300μs, Duty Cycle<2% (3) Repetitive rating: Pulse width limited by max. junction temperature

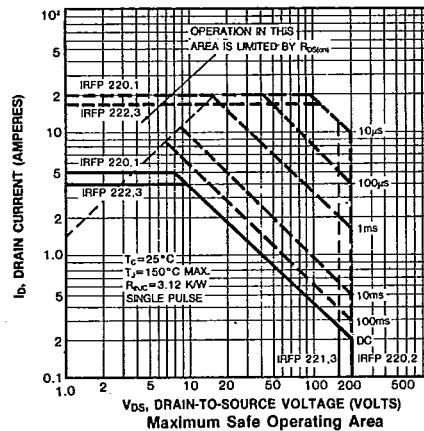
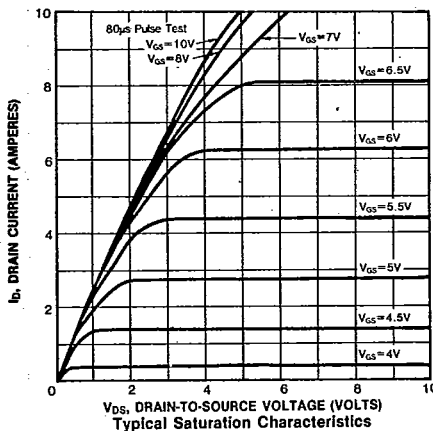
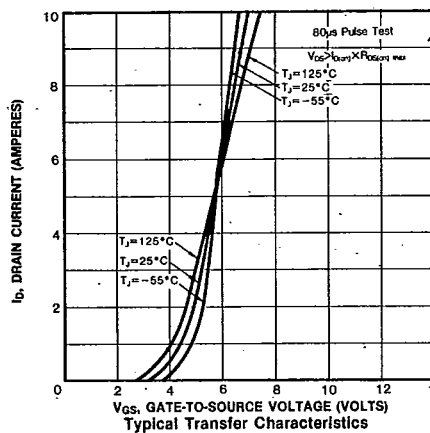
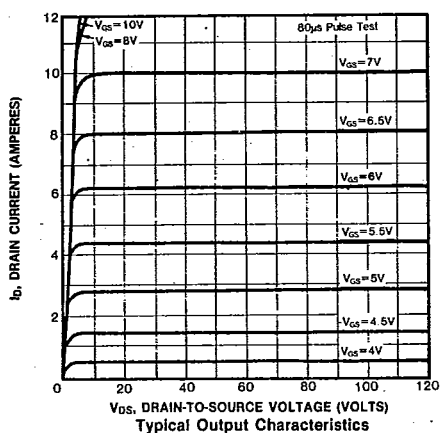

IRFP220/221/222/223

N-CHANNEL
POWER MOSFETS

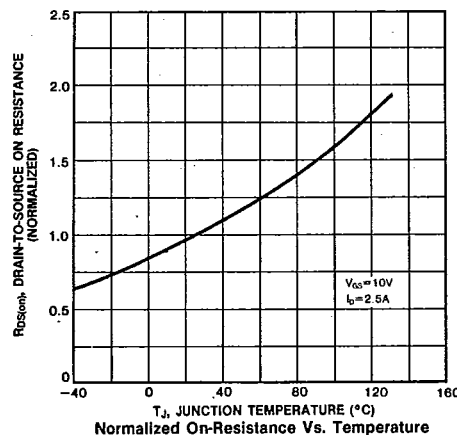
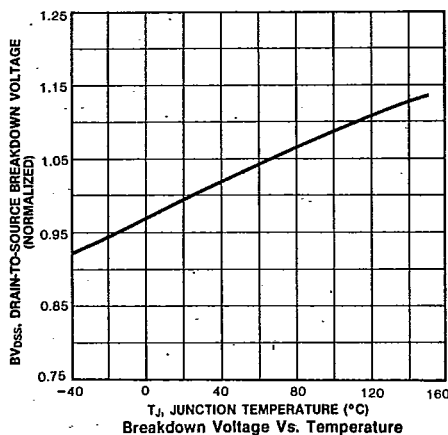
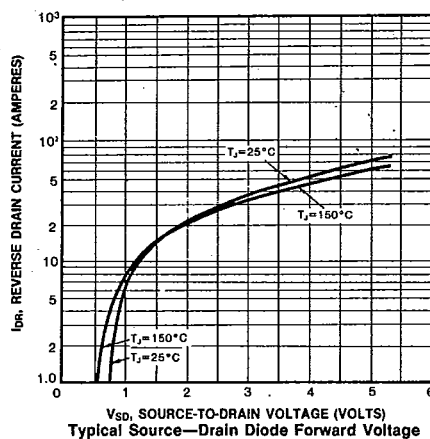
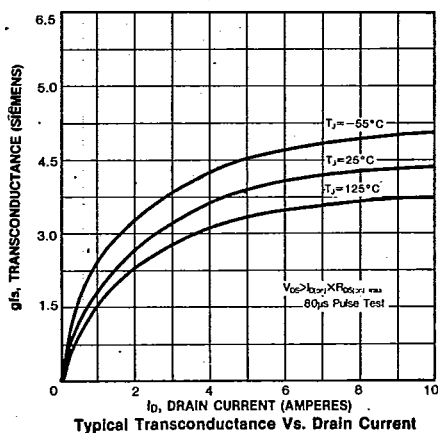
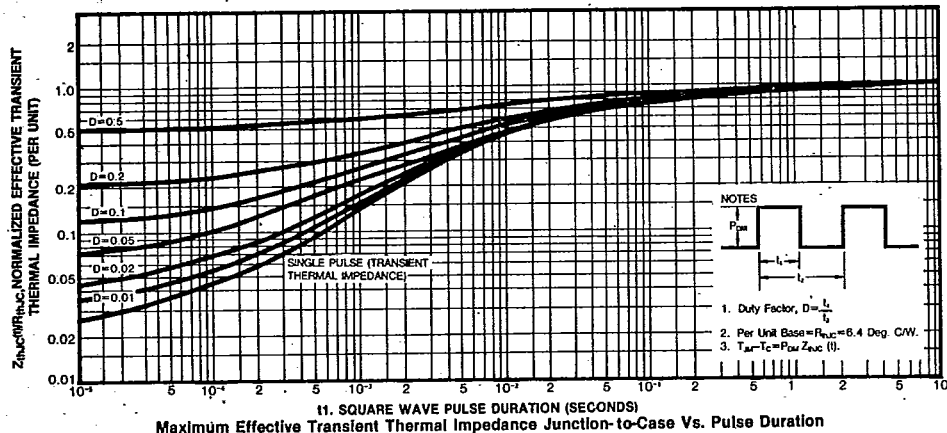

IRFP220/221/222/223

**N-CHANNEL
POWER MOSFETS**

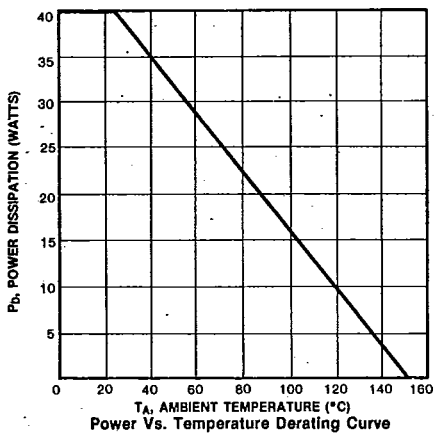
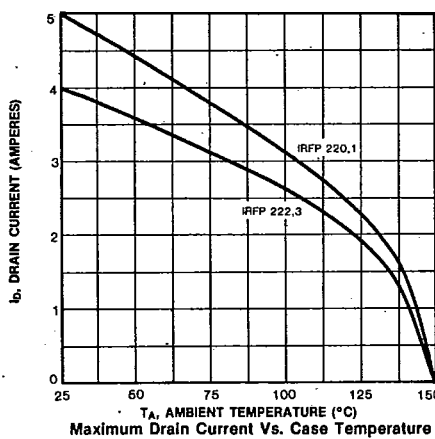
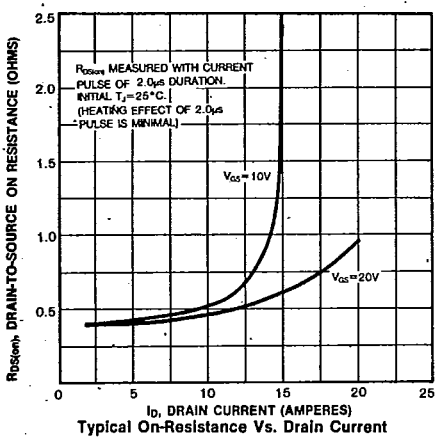
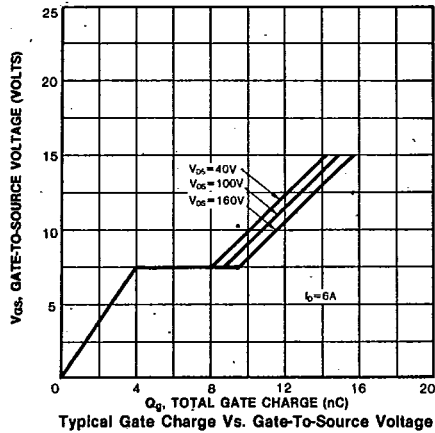
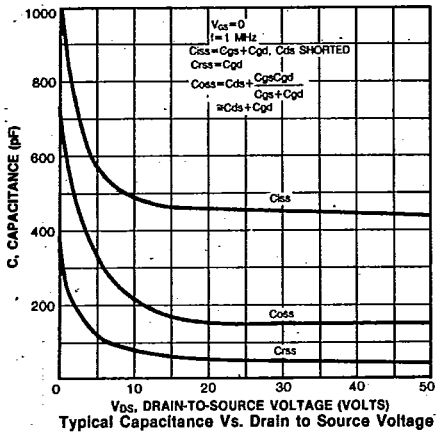

PACKAGE DIMENSIONS

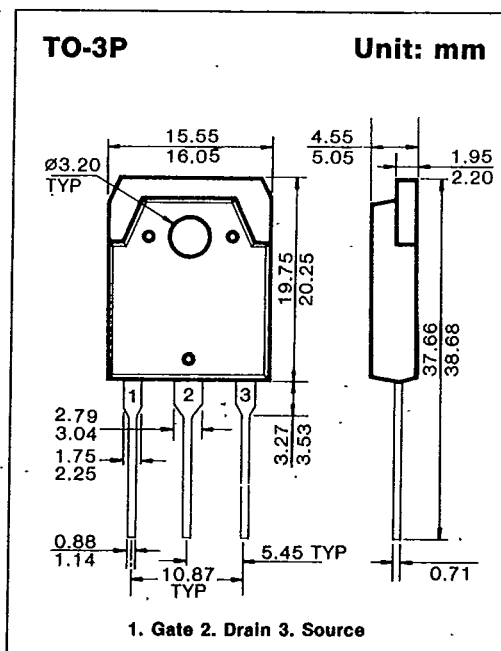
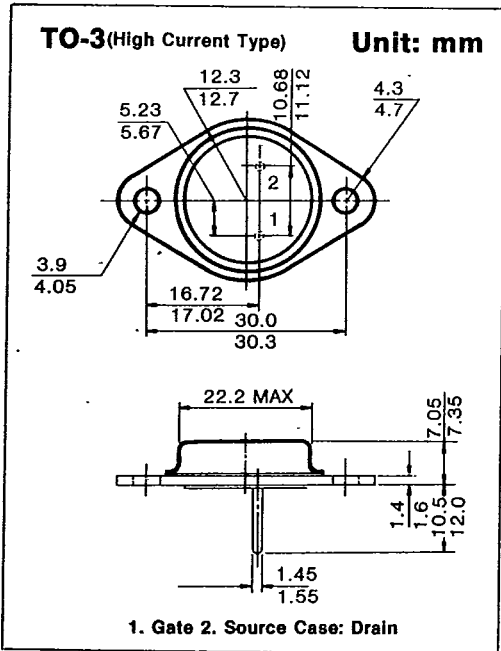
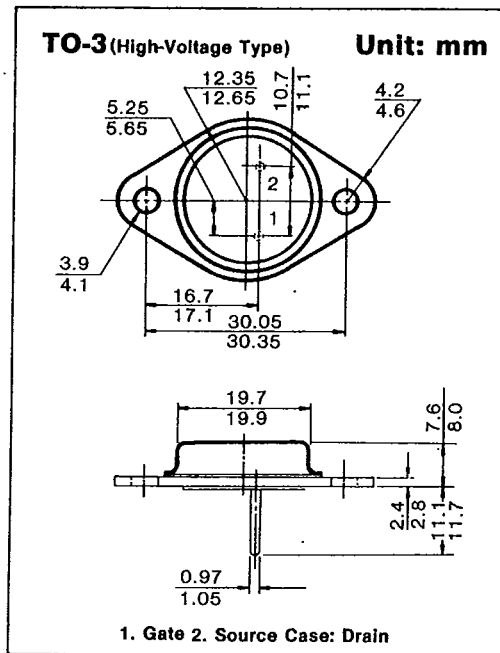
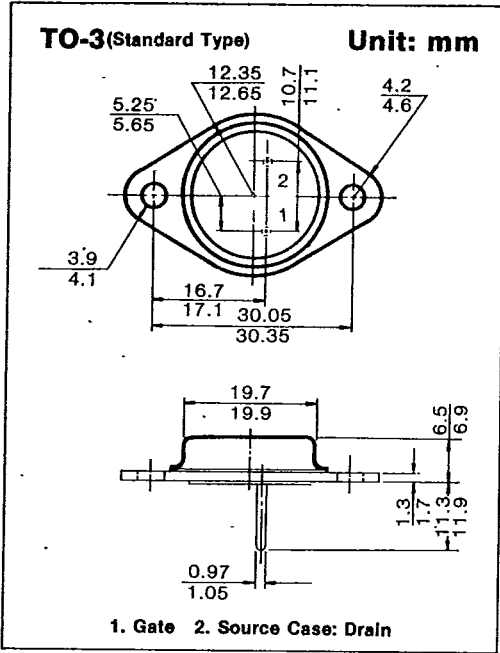

PACKAGE DIMENSIONS

