

53253**RADIATION TOLERANT, 90V - 0.8A
DUAL POWER MOSFET OPTOCOUPERS****Mii**

MICROCIRCUITS DIVISION

Features:

- Designed for 100 krad(Si) Total Dose
- 8-Pin Dual-In-Line Hermetic Package
- Performance over -55°C to +125°C
- Compact Isolation Solid State Switches
- Continuous Output Current: 0.8 A ⁽¹⁾
- Optically Coupled between Input and Output
- Isolation Tested to 1000 VDC
- High Level of Transient Immunity
- 3 A Output Surge Current
- Shock and Vibration Resistant
- MIL-PRF-38534 screening optional

Applications:

- Satellite/Space systems
- Military/High Reliability Systems
- Standard 28 VDC and 48 VDC Load Driver
- Aircraft Controls
- Electromechanical and Solid State Relay Replacement
- I/O Modules
- Switching Heaters

DESCRIPTION

The 53253 is two power MOSFET optocouplers in a single 8-pin dual-in-line package suitable for applications where two independent switches and radiation tolerant performance are required. The popular hermetic eight-pin dual-in-line ceramic package combined with 1000 VDC isolation between input and output and between two isolated relays, makes this device ideal for solid-state relay applications. Performance is specified over the full military temperature range. This device is available as COTS, or screened to MIL-PRF-38534, Table C-IX, Class H or custom screening. Lead options support both through-hole and surface-mount assembly. Gold plated leads are standard, but other lead finishes per MIL-PRF-38534 are also available.

Functionally, the device operates as two SPST, normally open (2 Form A) solid-state relays. Each relay is actuated by an input current, which can be driven from a standard TTL device. The input current biases a light emitting diode that is optically coupled to an integrated photovoltaic diode array. The photovoltaic diode array energizes control circuitry that operates the output MOSFET.

Micropac Industries cannot assume any responsibility for any circuits shown or represent that they are free from patent infringement. Micropac reserves the right to make changes at any time in order to improve design and to supply the best product possible.

MICROPAC INDUSTRIES, INC. MICROCIRCUITS DIVISION . 905 E. Walnut St., Garland, TX 75040 . (972) 272-3571 . Fax (972) 494-2281
www.micropac.com E-MAIL: microsales@micropac.com

8/30/02
Pg. 1 of 6

ABSOLUTE MAXIMUM RATINGS:

(Per relay unless otherwise noted)

Storage Temperature Range	-65°C to +150°C
Operating Ambient Temperature - T_A	-55°C to +125°C
Junction Temperature - T_J	+150°C
Lead Solder Temperature for 10 seconds	+260°C (1.6 mm below seating plane)
Average Input Current - I_F	20 mA
Peak Repetitive Input Current - I_{Fpk}	40 mA (pulse width < 100 ms; duty cycle < 50%)
Peak Surge Input Current - I_{Fpk} surge	100 mA (pulse width < 0.2 ms; duty cycle < 0.1%)
Continuous Output Current per relay - I_O	0.8 A ⁽¹⁾
Single Shot Output Current per relay- I_{Opk} surge (pulse width < 10 ms)	3 A
Output Voltage - V_O	90 VDC

RECOMMENDED OPERATING CONDITIONS:

Parameter	Symbol	Min.	Max.	Units
Input Current (ON)	$I_{F(ON)}$	5	20	mA
Input Voltage (OFF)	$V_{F(OFF)}$	0	0.6	VDC
Operating Temperature	T_A	-55	+125	°C

Micropac Industries cannot assume any responsibility for any circuits shown or represent that they are free from patent infringement.
Micropac reserves the right to make changes at any time in order to improve design and to supply the best product possible.

ELECTRICAL SPECIFICATIONS (Pre-Irradiation)

$T_A = -55^\circ\text{C}$ to $+125^\circ\text{C}$, unless otherwise specified.

Parameter	Symbol	Min.	Typ.*	Max.	Units	Test Conditions	Notes
Output Withstand Voltage	$V_{O(OFF)}$	90			V	$V_F = 0.6\text{ V}$ $I_O = 10\ \mu\text{A}$	
Output On-Resistance	$R_{(ON)}$		0.6	1.2	Ω	$I_F = 10\text{ mA}$ $I_O = 0.8\text{ A}$ pulse duration $\leq 30\text{ ms}$ duty cycle $< 10\%$	2
Output Leakage Current	$I_{O(OFF)}$			10	μA	$V_F = 0.6\text{ V}$ $V_O = 90\text{ V}$	
Input Forward Voltage	V_F	1.0	1.6	2.1	V	$I_F = 10\text{ mA}$	
Input Reverse Breakdown Voltage	V_R	5			V	$I_F = 10\ \mu\text{A}$	
Input-Output Isolation	I_{I-O}			1	μA	$RH \leq 45\%$, $t = 5\text{ s}$ $V_{I-O} = 1000\text{ VDC}$ $T_A = 25^\circ\text{C}$	3
Channel-channel Isolation	I_{ISO}			1	μA	$RH \leq 45\%$, $t = 5\text{ s}$ $V_{ISO} = 1000\text{ VDC}$ $T_A = 25^\circ\text{C}$	3
Turn-On Time	t_{ON}			6	ms	$I_F = 10\text{ mA}$ $V_O = 28\text{ V}$ $I_O = 0.8\text{ A}$ duty cycle $< 10\%$	2
Turn-Off time	t_{OFF}			2	ms	$I_F = 10\text{ mA}$ $V_O = 28\text{ V}$ $I_O = 0.8\text{ A}$ duty cycle $< 10\%$	2

* All typical values are at $T_A = 25^\circ\text{C}$, $I_{F(OFF)} = 10\text{ mA}$, $V_{F(OFF)} = 0.6\text{ V}$ unless otherwise specified.

Notes:

1. Maximum average current rating where the case temperature (T_C) is maintained below 120°C .
2. During the pulsed R_{ON} measurement (I_O duration $< 30\text{ ms}$), ambient (T_A) and case temperature (T_C) are equal.
3. This is a momentary withstand test, not a continuous operating condition.
4. Typical junction to case thermal resistance (θ_{JC}) for the device is 15°C/W , where case temperature (T_C) is measured at the center of the package bottom.

CAUTION:

Care should be taken not to exceed the maximum output power dissipation, maximum case temperature, and maximum junction temperature when repetitively switching loads.

Micropac Industries cannot assume any responsibility for any circuits shown or represent that they are free from patent infringement. Micropac reserves the right to make changes at any time in order to improve design and to supply the best product possible.

Terminal number	Terminal Symbol
1	+IN 1
2	- IN 1
3	- OUT 2
4	+OUT 2
5	+IN 2
6	- IN 2
7	- OUT 1
8	+OUT 1

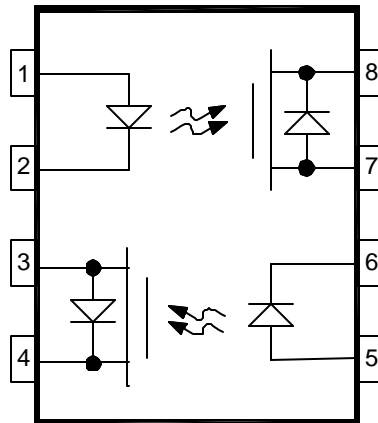

Figure 1 - Terminal Connections

INPUT	OUTPUT
OFF	OFF
ON	ON

Figure 2 - Truth Table

Micropac Industries cannot assume any responsibility for any circuits shown or represent that they are free from patent infringement.
 Micropac reserves the right to make changes at any time in order to improve design and to supply the best product possible.

Case Outlines

CASE OUTLINE P

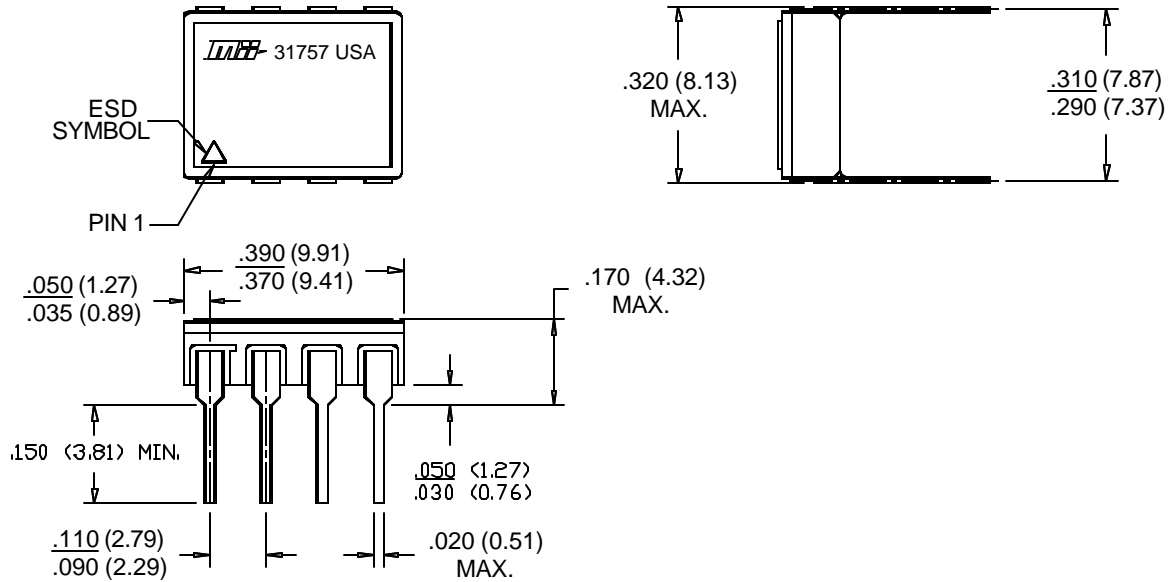

CASE OUTLINE X

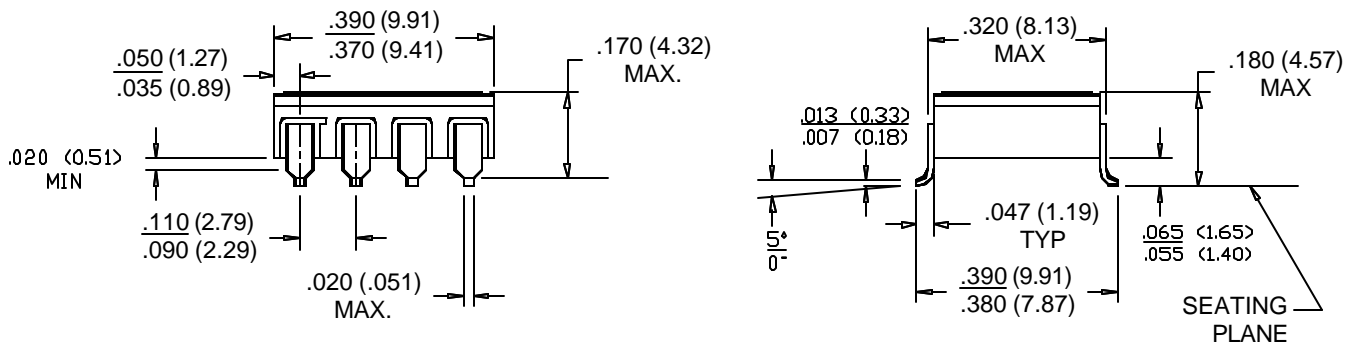

NOTES:

- PIN 1 IS INDICATED BY THE ESD TRIANGLE MARKED ON THE LID OF THE PACKAGE.
- DIMENSIONS ARE IN INCHES, (mm).
- METRIC EQUIVALENTS ARE GIVEN FOR GENERAL INFORMATION ONLY.
- UNLESS OTHERWISE SPECIFIED, TOLERANCE IS ± 0.005 (0.13mm).

Micropac Industries cannot assume any responsibility for any circuits shown or represent that they are free from patent infringement.
Micropac reserves the right to make changes at any time in order to improve design and to supply the best product possible.

Ordering Guide

The following chart explains the ordering procedure for Micropac Part Numbers.
Please contact Micropac for other desired options.

Example Mii P/N 53253-PA-H

<u>53253-</u>	<u>P</u>	<u>A</u>	<u>-H</u>
	<u>Case Outline</u>	<u>Lead Finish</u>	<u>Quality Level</u>
Device Type & Model Number	P: 8-Pin DIP X: 8-Pin Gull Wing	A: Solder DIP C: Gold Plate X: Either A or C	None: Per Data Sheet H: Class H, MIL-PRF-38534 K: Class K, MIL-PRF-38534

Micropac Industries cannot assume any responsibility for any circuits shown or represent that they are free from patent infringement.
Micropac reserves the right to make changes at any time in order to improve design and to supply the best product possible.