

Document No.	853-0813
ECN No.	90829
Date of Issue	October 7, 1987
Status	Product Specification
RF Communications	

NE/SA572

Programmable analog compandor

DESCRIPTION

The NE572 is a dual-channel, high-performance gain control circuit in which either channel may be used for dynamic range compression or expansion. Each channel has a full-wave rectifier to detect the average value of input signal, a linearized, temperature-compensated variable gain cell (ΔG) and a dynamic time constant buffer. The buffer permits independent control of dynamic attack and recovery time with minimum external components and improved low frequency gain control ripple distortion over previous compandors.

The NE572 is intended for noise reduction in high-performance audio systems. It can also be used in a wide range of communication systems and video recording applications.

FEATURES

- Independent control of attack and recovery time
- Improved low frequency gain control ripple
- Complementary gain compression and expansion with external op amp
- Wide dynamic range—greater than 110dB
- Temperature-compensated gain control
- Low distortion gain cell
- Low noise— $6\mu\text{V}$ typical
- Wide supply voltage range—6V-22V
- System level adjustable with external components

APPLICATIONS

- Dynamic noise reduction system
- Voltage control amplifier
- Stereo expander
- Automatic level control
- High-level limiter
- Low-level noise gate
- State variable filter

PIN CONFIGURATION

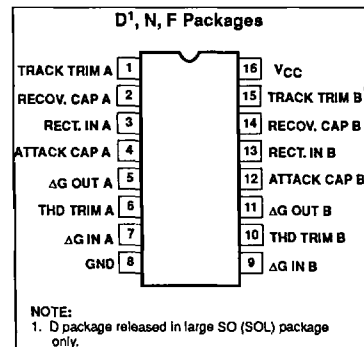

ORDERING INFORMATION

DESCRIPTION	TEMPERATURE RANGE	ORDER CODE
16-Pin Plastic SO	0 to +70°C	NE572D
16-Pin Plastic DIP	0 to +70°C	NE572N
16-Pin Plastic SO	-40 to +85°C	SA572D
16-Pin Cerdip	-40 to +85°C	SA572F
16-Pin Plastic DIP	-40 to +85°C	SA572N

Programmable analog compandor

NE/SA572

BLOCK DIAGRAM

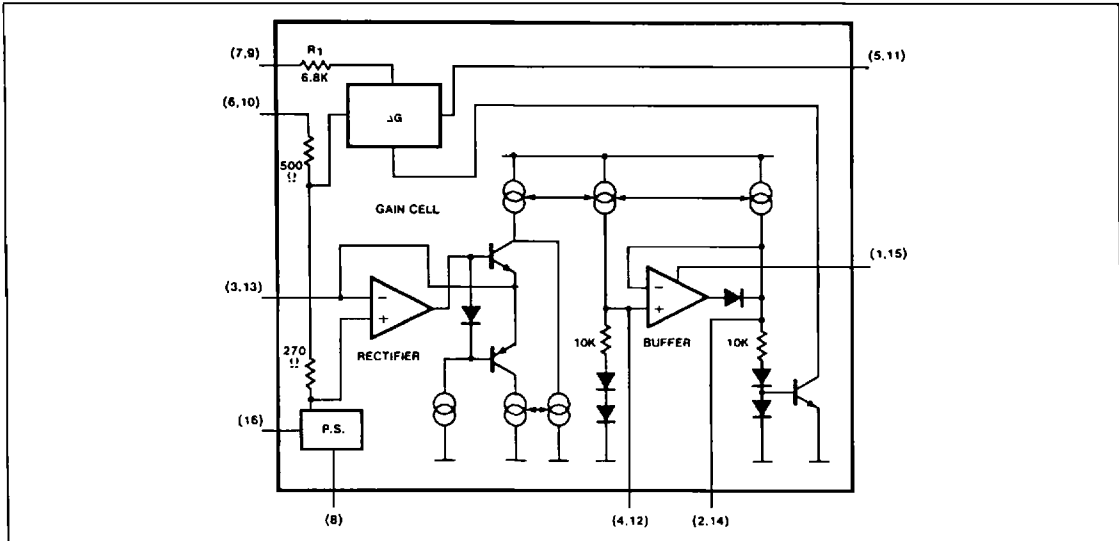

ABSOLUTE MAXIMUM RATINGS

SYMBOL	PARAMETER	RATING	UNIT
V_{CC}	Supply voltage	22	V_{DC}
T_A	Operating temperature range	0 to +70 -40 to +85	$^{\circ}C$
P_D	Power dissipation	500	mW

DC ELECTRICAL CHARACTERISTICS

Standard test conditions (unless otherwise noted) $V_{CC}=15V$, $T_A=25^{\circ}C$; Expander mode (see Test Circuit). Input signals at unity gain level (0dB) = $100mV_{RMS}$ at 1kHz; $V_1 = V_2$; $R_2 = 3.3k\Omega$; $R_3 = 17.3k\Omega$.

SYM-BOL	PARAMETER	TEST CONDITIONS	NE572			SA572			UNIT
			Min	Typ	Max	Min	Typ	Max	
V_{CC}	Supply voltage		6		22	6		22	V_{DC}
I_{CC}	Supply current	No signal			6			6.3	mA
V_R	Internal voltage reference		2.3	2.5	2.7	2.3	2.5	2.7	V_{DC}
THD	Total harmonic distortion (untrimmed)	1kHz $C_A=1.0\mu F$		0.2	1.0		0.2	1.0	%
THD	Total harmonic distortion (trimmed)	1kHz $C_R=10\mu F$		0.05			0.05		%
THD	Total harmonic distortion (trimmed)	100Hz		0.25			0.25		%
	No signal output noise	Input to V_1 and V_2 grounded (20–20kHz)		6	25		6	25	μV

Programmable analog compandor

NE/SA572

DC ELECTRICAL CHARACTERISTICS

SYM-BOL	PARAMETER	TEST CONDITIONS	NE572			SA572			UNIT
			Min	Typ	Max	Min	Typ	Max	
	DC level shift (untrimmed)	Input change from no signal to 100mV _{RMS}		±20	±50		±20	±50	mV
	Unity gain level		-1	0	+1	-1.5	0	+1.5	dB
	Large-signal distortion	V ₁ =V ₂ =400mV		0.7	3.0		0.7	3	%
	Tracking error (measured relative to value at unity gain)= [V _O -V _O (unity gain)]dB -V ₂ dB	Rectifier input V ₂ =+6dB V ₁ =0dB V ₂ =-30dB V ₁ =0dB		±0.2 ±0.5	-1.5 +0.8		±0.2 ±0.5	-2.5 +1.6	dB
	Channel crosstalk	200mV _{RMS} into channel A, measured output on channel B	60			60			dB
PSRR	Power supply rejection ratio	120Hz		70			70		dB

TEST CIRCUIT

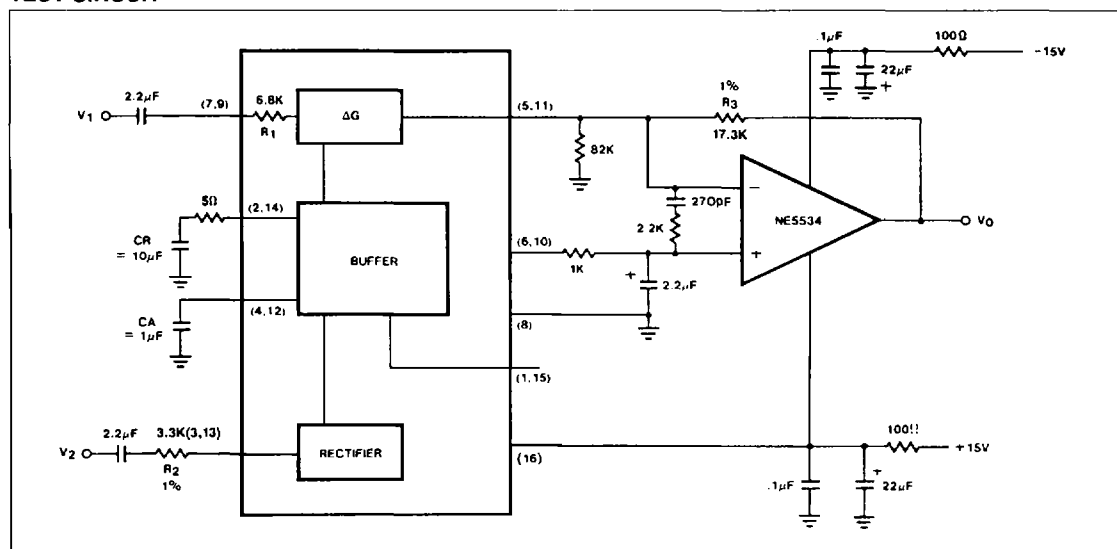

AUDIO SIGNAL PROCESSING IC COMBINES VCA AND FAST ATTACK/SLOW RECOVERY LEVEL SENSOR

In high-performance audio gain control applications, it is desirable to independently control the attack and recovery time of the gain control signal. This is true, for example, in compandor applications for noise reduction. In high end systems the input signal is usually split into two or more frequency bands to optimize the dynamic behavior for each band. This reduces low

frequency distortion due to control signal ripple, phase distortion, high frequency channel overload and noise modulation. Because of the expense in hardware, multiple band signal processing up to now was limited to professional audio applications.

With the introduction of the Signetics NE572 this high-performance noise reduction concept becomes feasible for consumer hi fi applications. The NE572 is a dual channel gain control IC. Each channel has a linearized, temperature-compensated gain cell and an improved level sensor. In

conjunction with an external low noise op amp for current-to-voltage conversion, the VCA features low distortion, low noise and wide dynamic range.

The novel level sensor which provides gain control current for the VCA gives lower gain control ripple and independent control of fast attack, slow recovery dynamic response. An attack capacitor C_A with an internal 10k resistor R_A defines the attack time t_A. The recovery time t_R of a tone burst is defined by a recovery capacitor C_R and an internal 10k resistor R_R. Typical attack time of 4ms for

Programmable analog compandor

NE/SA572

the high-frequency spectrum and 40ms for the low frequency band can be obtained with 0.1µF and 1.0µF attack capacitors, respectively. Recovery time of 200ms can be obtained with a 4.7µF recovery capacitor for a 100Hz signal, the third harmonic distortion is improved by more than 10dB over the simple RC ripple filter with a single 1.0µF attack and recovery capacitor, while the attack time remains the same.

The NE572 is assembled in a standard 16-pin dual in-line plastic package and in oversized SOL package. It operates over a wide supply range from 6V to 22V. Supply current is less than 6mA. The NE572 is designed for consumer application over a temperature range 0-70 The SA572 is intended for applications from -40°C to +85°C.

NE572 BASIC APPLICATIONS

Description

The NE572 consists of two linearized, temperature-compensated gain cells (ΔG), each with a full-wave rectifier and a buffer amplifier as shown in the block diagram. The two channels share a 2.5V common bias reference derived from the power supply but otherwise operate independently. Because of inherent low distortion, low noise and the capability to linearize large signals, a wide dynamic range can be obtained. The buffer amplifiers are provided to permit control of attack time and recovery time independent of each other. Partitioned as shown in the block diagram, the IC allows flexibility in the design of system levels that optimize DC shift, ripple distortion, tracking accuracy and noise floor for a wide range of application requirements.

Gain Cell

Figure 1 shows the circuit configuration of the gain cell. Bases of the differential pairs Q₁-Q₂ and Q₃-Q₄ are both tied to the output and inputs of OPA A₁. The negative feedback through Q₁ holds the V_{BE} of Q₁-Q₂ and the V_{BE} of Q₃-Q₄ equal. The following relationship can be derived from the transistor model equation in the forward active region.

$$\Delta V_{BE_{Q3Q4}} = \Delta V_{BE_{Q1Q2}}$$

$$(V_{BE} = V_T \ln IC/IS)$$

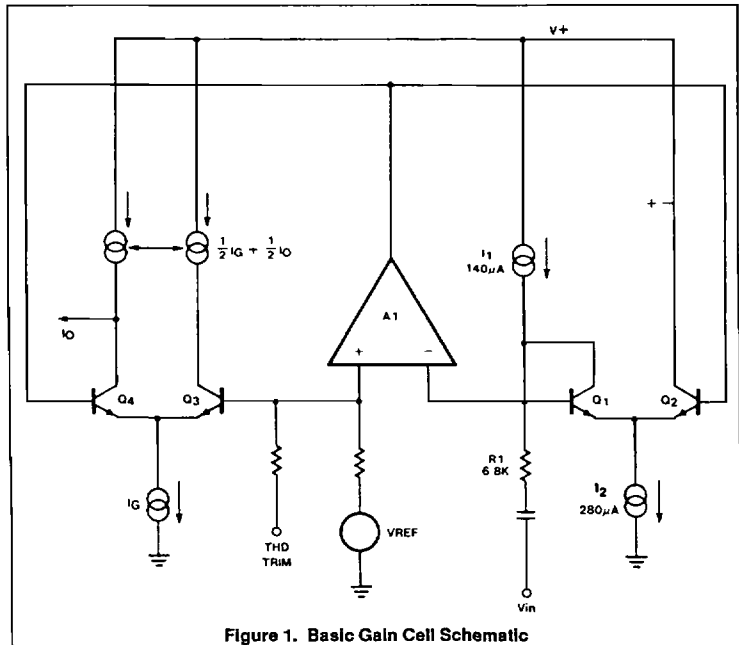

Figure 1. Basic Gain Cell Schematic

$$V_{Tn} \left(\frac{\frac{1}{2} I_G + \frac{1}{2} I_O}{I_S} \right) - V_{Tn} \left(\frac{\frac{1}{2} I_G - \frac{1}{2} I_O}{I_S} \right)$$

$$V_{Tn} \left(\frac{I_1 + I_{IN}}{I_S} \right) - V_{Tn} \left(\frac{I_2 - I_1 - I_{IN}}{I_S} \right) \quad (2)$$

where $I_{IN} = \frac{V_{IN}}{R_1}$

- R₁ = 6.8kΩ
- I₁ = 140µA
- I₂ = 280µA

I_O is the differential output current of the gain cell and I_G is the gain control current of the gain cell.

If all transistors Q₁ through Q₄ are of the same size, equation (2) can be simplified to:

$$I_O = \frac{2}{I_2} \cdot I_{IN} \cdot I_G - \frac{1}{I_2} (I_2 - 2I_1) \cdot I_G \quad (3)$$

The first term of Equation 3 shows the multiplier relationship of a linearized two quadrant transconductance amplifier. The second term is the gain control feedthrough due to the mismatch of devices. In the

design, this has been minimized by large matched devices and careful layout. Offset voltage is caused by the device mismatch and it leads to even harmonic distortion. The offset voltage can be trimmed out by feeding a current source within ±25µA into the THD trim pin. The residual distortion is third harmonic distortion and is caused by gain control ripple. In a compandor system, available control of fast attack and slow recovery improve ripple distortion significantly. At the unity gain level of 100mV, the gain cell gives THD (total harmonic distortion) of 0.17% typ. Output noise with no input signals is only 6µV in the audio spectrum (10Hz-20kHz). The output current I_O must feed the virtual ground input of an operational amplifier with a resistor from output to inverting input. The non-inverting input of the operational amplifier has to be biased at V_{REF} if the output current I_O is DC coupled.

Rectifier

The rectifier is a full-wave design as shown in Figure 2. The input voltage is converted to current through the input resistor R₂ and turns on either Q₅ or Q₆ depending on the signal polarity. Deadband of the voltage to current converter is reduced by the loop gain

Programmable analog compandor

NE/SA572

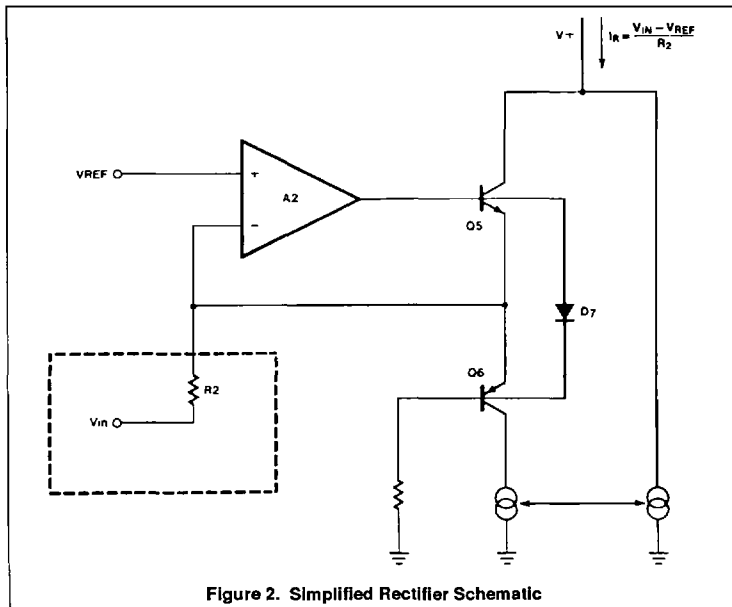

Figure 2. Simplified Rectifier Schematic

of the gain block A₂. If AC coupling is used, the rectifier error comes only from input bias current of gain block A₂. The input bias current is typically about 70nA. Frequency response of the gain block A₂ also causes second-order error at high frequency. The collector current of Q₆ is mirrored and summed at the collector of Q₅ to form the full wave rectified output current I_R. The rectifier transfer function is

$$I_R = \frac{V_{IN} - V_{REF}}{R_2} \quad (4)$$

If V_{IN} is AC-coupled, then the equation will be reduced to:

$$I_{RAC} = \frac{V_{IN}(AVG)}{R_2}$$

The internal bias scheme limits the maximum output current I_R to be around 300µA. Within a ±1dB error band the input range of the rectifier is about 52dB.

Buffer Amplifier

In audio systems, it is desirable to have fast attack time and slow recovery time for a tone burst input. The fast attack time reduces transient channel overload but also causes low-frequency ripple distortion. The low-frequency ripple distortion can be improved with the slow recovery time. If different attack times are implemented in corresponding frequency spectrums in a split band audio system, high quality performance can be achieved. The buffer amplifier is designed to make this feature available with minimum external components. Referring to Figure 3, the rectifier output current is mirrored into the input and output of the unipolar buffer amplifier A₃ through Q₈, Q₉ and Q₁₀. Diodes D₁₁ and D₁₂ improve tracking accuracy and provide common-mode bias for A₃. For a positive-going input signal, the buffer amplifier acts like a voltage-follower. Therefore, the output impedance of A₃ makes the contribution of capacitor CR to attack time insignificant. Neglecting diode impedance, the gain Ga(t) for ΔG can be expressed as follows:

$$Ga(t) = (G_{AINT} - G_{AFNL} e^{-t/\tau_A} + G_{AFNL})$$

G_{AINT}=Initial Gain

G_{AFNL}=Final Gain

$$\tau_A = R_A \cdot CA = 10k \cdot CA$$

where τ_A is the attack time constant and R_A is a 10k internal resistor. Diode D₁₅ opens the feedback loop of A₃ for a negative-going signal if the value of capacitor CR is larger than capacitor CA. The recovery time depends only on CR • R_R. If the diode

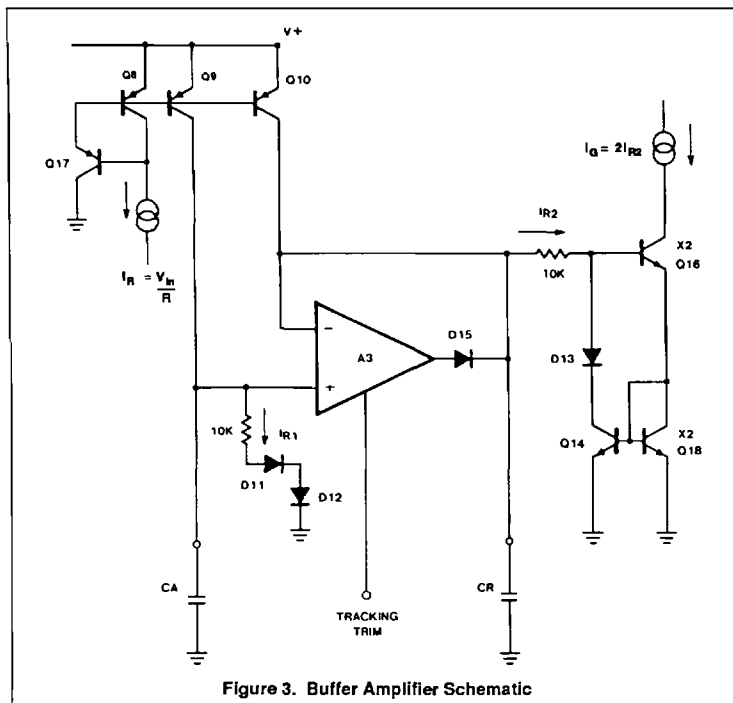

Figure 3. Buffer Amplifier Schematic

Programmable analog compandor

NE/SA572

impedance is assumed negligible, the dynamic gain $G_R(t)$ for ΔG is expressed as follows.

$$G_R(t) = (G_{RINT} - G_{RFNL} e^{-\frac{t}{\tau R}} + G_{RFNL})$$

$$G_R(t) = (G_{RINT} - G_{RFNL}) \theta + G_{RFNL}$$

$$\tau R = R_R \cdot CR = 10k \cdot CR$$

where τR is the recovery time constant and R_R is a 10k internal resistor. The gain control current is mirrored to the gain cell through Q_{14} . The low level gain errors due to input bias current of A_2 and A_3 can be trimmed through the tracking trim pin into A_3 with a current source of $\pm 3\mu A$.

Basic Expander

Figure 4 shows an application of the circuit as a simple expander. The gain expression of the system is given by

$$\frac{V_{OUT}}{V_{IN}} = \frac{2}{I_1} \cdot \frac{R_3 \cdot V_{IN(AVG)}}{R_2 \cdot R_1} \quad (5)$$

$$(I_1 = 140\mu A)$$

Both the resistors R_1 and R_2 are tied to internal summing nodes. R_1 is a 6.8k internal resistor. The maximum input current into the gain cell can be as large as 140 μA . This corresponds to a voltage level of 140 μA • 6.8k=952mV peak. The input peak current into the rectifier is limited to 300 μA by the

internal bias system. Note that the value of R_1 can be increased to accommodate higher input level. R_2 and R_3 are external resistors. It is easy to adjust the ratio of R_3/R_2 for desirable system voltage and current levels. A small R_2 results in higher gain control current and smaller static and dynamic tracking error. However, an impedance buffer A_1 may be necessary if the input is voltage drive with large source impedance.

The gain cell output current feeds the summing node of the external OPA A_2 . R_3 and A_2 convert the gain cell output current to the output voltage. In high-performance applications, A_2 has to be low-noise, high-speed and wide band so that the high-performance output of the gain cell will not be degraded. The non-inverting input of A_2 can be biased at the low noise internal reference Pin 6 or 10. Resistor R_4 is used to bias up the output DC level of A_2 for maximum swing. The output DC level of A_2 is given by

$$V_{ODC} = V_{REF} \left(1 + \frac{R_3}{R_4} \right) - V_B \frac{R_3}{R_4} \quad (6)$$

V_B can be tied to a regulated power supply for a dual supply system and be grounded for a single supply system. CA sets the attack time constant and CR sets the recovery time constant. *5COL

Basic Compressor

Figure 5 shows the hook-up of the circuit as a compressor. The IC is put in the feedback loop of the OPA A_1 . The system gain expression is as follows:

$$\frac{V_{OUT}}{V_{IN}} = \left(\frac{I_1}{2} \cdot \frac{R_2 \cdot R_1}{R_3 \cdot V_{IN(AVG)}} \right)^{\frac{1}{2}} \quad (7)$$

R_{DC1} , R_{DC2} , and CDC form a DC feedback for A_1 . The output DC level of A_1 is given by

$$V_{ODC} = V_{REF} \left(1 + \frac{R_{DC1} + R_{DC2}}{R_4} \right) - V_B \cdot \left(\frac{R_{DC1} + R_{DC2}}{R_4} \right) \quad (8)$$

The zener diodes D_1 and D_2 are used for channel overload protection.

Basic Compandor System

The above basic compressor and expander can be applied to systems such as tape/disc noise reduction, digital audio, bucket brigade delay lines. Additional system design techniques such as bandlimiting, band splitting, pre-emphasis, de-emphasis and equalization are easy to incorporate. The IC is a versatile functional block to achieve a high performance audio system. Figure 6 shows the system level diagram for reference.

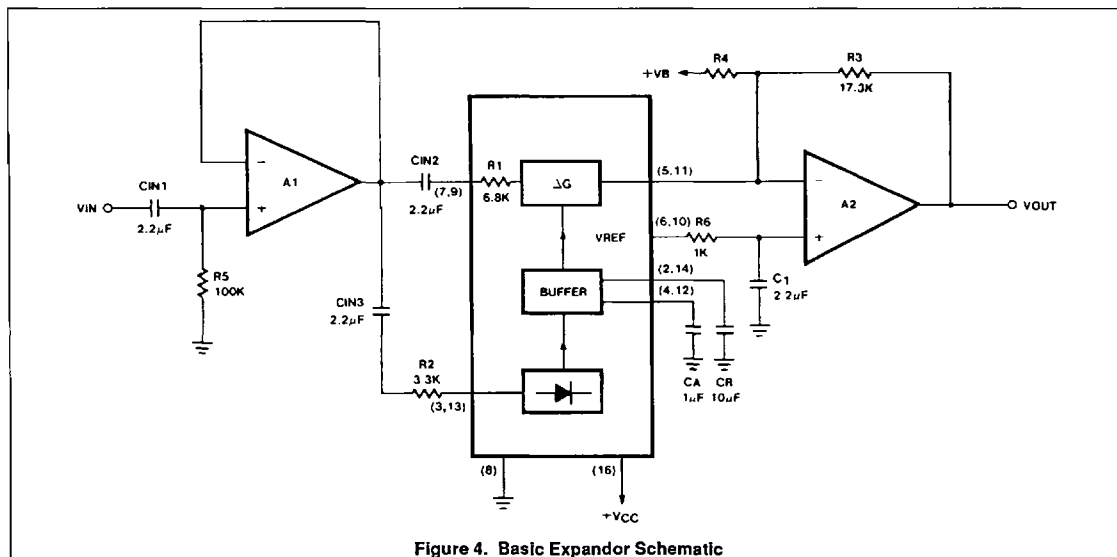

Figure 4. Basic Expander Schematic

Programmable analog compandor

NE/SA572

