

Solid State Current Sensors



Engineering Specifications	LDA100	LDA101	LDA110	LDA111	LDA200	LDA201	LDA210	LDA211
Output Characteristics								
Collector Current (mA)	100	100	100	100	100	100	100	100
Typical Capacitance (pF) ($V_{ce} = 10V$; $f = 1MHz$)	3	3	3	3	3	3	3	3
Collector Dark Current (nA) ($V_{ce} = 5V$; $I_F = 0mA$)	500	500	1000	1000	500	500	1000	1000
Input Characteristics								
Max Power Dissipation Per Stage (mW) Derate 1.33 mW/°C above 25° Ambient	190	190	190	190	190	190	190	190
Max Cont. Forward Current (mA)	100	100	100	100	100	100	100	100
Max Peak Forward Current (A) Pulse width 1us 300 pps	3	3	3	3	3	3	3	3
Max Reverse Voltage (V)	—	5	—	5	—	5	—	5
Forward Voltage (V) Minimum Maximum	0.9 1.4	0.9 1.4	0.9 1.4	0.9 1.4	0.9 1.4	0.9 1.4	0.9 1.4	0.9 1.4
Max Capacitance (pF) ($V = 0$; $f = 1MHz$)	50	50	50	50	50	50	50	50
Product Selector Guide								
Current Transfer Ratio (Typical)	100% ²	100% ²	750% ³	750% ³	100% ²	100% ²	750% ³	750% ³
V_{ce} (V); $I_F = 0$	50	50	50	50	50	50	50	50
V_{ce} (V); $I_F = 15mA$, $I_C = 2mA$	0.3	0.3	1.0	1.0	0.3	0.3	1.0	1.0
Package Style	A	B	C	D	E	F	G	H

Features:

- AC and DC input versions available
- 3,750 Volt input-to-output isolation
- Small DIP package
- Broad selection includes multiple sensors in a single package
- 100 mA continuous load rating
- UL recognized: File No. E76270
- VDE, CSA compatible
- BAPT Approved

Absolute Maximum Ratings

Parameter	Min	Max	Units
Isolation Voltage ¹	2500	—	V_{RMS}
Isolation Resistance (Input-to-Output Voltage = 500 VDC)	10 ¹¹	—	Ohms
Capacitance (Input-to-Output)	—	2	pF
Storage Temperature	-40	125	°C
Operating Temperature	-40	85	°C
Lead Soldering Time (10 seconds on leads)	—	260	°C
DC Current Transfer Ratio Single Transistor ² Darlington ³	33	—	%

¹3,750 V_{RMS} Isolation Voltage is available by specifying an "E" suffix.

² $I_F = 6mA$, $I_C = 2mA$, $V_{CE} = .5V$

³ $I_F = .5mA$, $I_C = 1.5mA$, $V_{CE} = 0.8V$

All characteristics at 25°C

Mechanical Dimensions

All dimensions are measured in millimeters (inches).

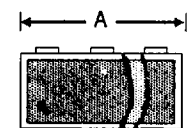
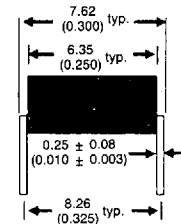
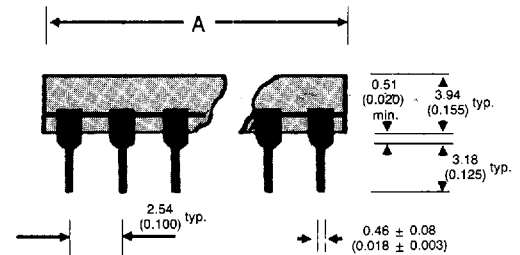

A ± 0.51 (± 0.020)	Pins
9.40 (0.370)	6
9.40 (0.370)	8

*For a complete listing of CP Clare Solid State Products ask for our SSP15 catalog.

Note: Gull-Wing SMD Packages available.

Solid State Current Sensors

Operating Specifications

Functional Diagrams

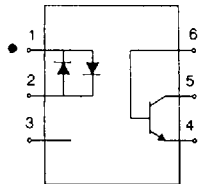

LDA100 : Pkg. A

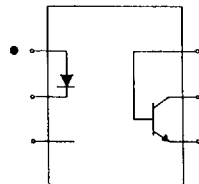

LDA101 : Pkg. B

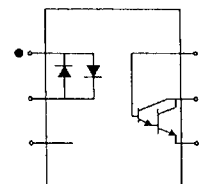

LDA110 : Pkg. C

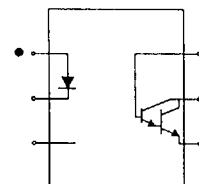

LDA111 : Pkg. D

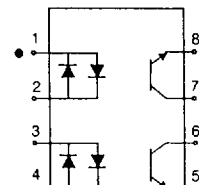

LDA200 : Pkg. E

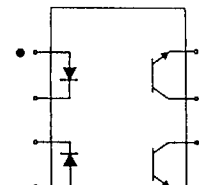

LDA201 : Pkg. F

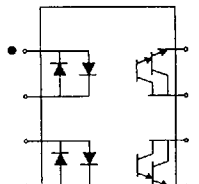

LDA210 : Pkg. G

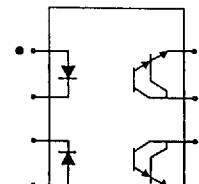

LDA211 : Pkg. H

• Indicates pin 1

Single Transistor Detector (Typical)

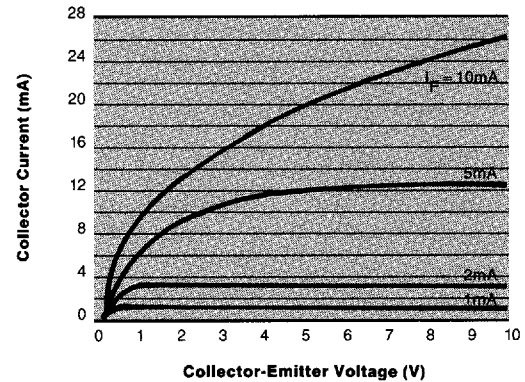

Darlington Detector (Typical)

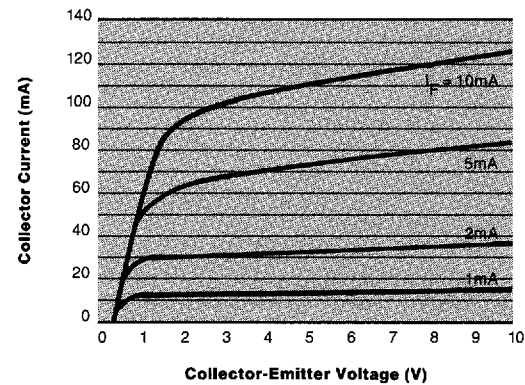

Specifying the correct part number for the proper LDA current sensor requires three parameters—X, Y, Z—which combine to form a part number ("LDAXYZ"):

- X: The desired number of sensors per package (1 or 2)
- Y: Single transistor ("0") or Darlington transistor ("1") output configuration
- Z: Number of input diodes (1-single input diode, 0 = two input diodes)
- Add "E" suffix to specify 3,750 Isolation Voltage
- Use the "S" suffix to specify Gull Wing packaging
- Use the "B" suffix to specify Butt End-Cut packaging

As an example, the LDA 2 1 1 specifies:

Z = 1 DC Operation with a single input diode
 Y = 1 Darlington transistor output

X = 2 There are two sensors in this package

Note: Special part numbers are available on an application/request basis.

Please request Application Brief 114 for more information about SMD package styles.

6 Pin Through Hole (Standard)

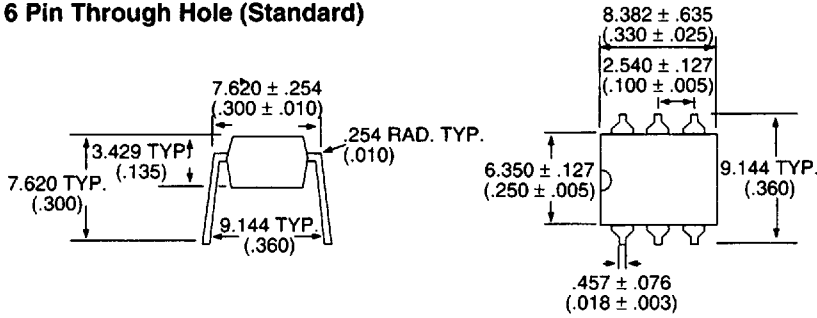

6 Pin PC Board Pattern (Bottom View)

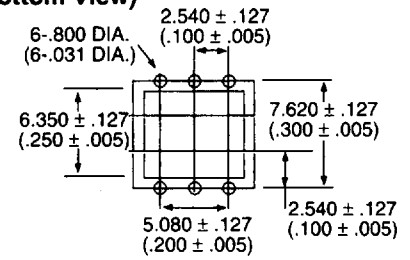

6 Pin Surface Mount ("S" Suffix)

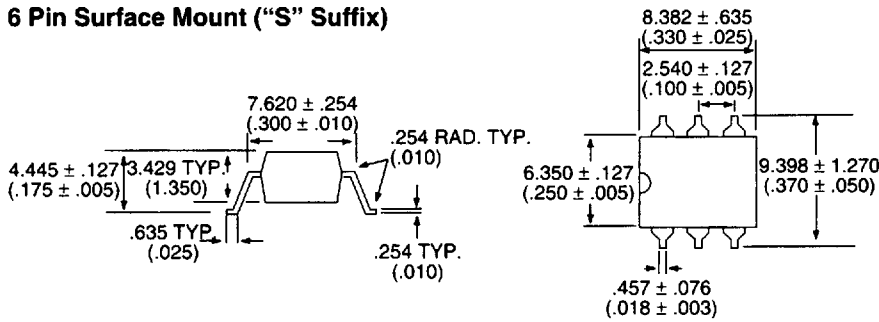

6 Pin Mounting Pad (Top View)

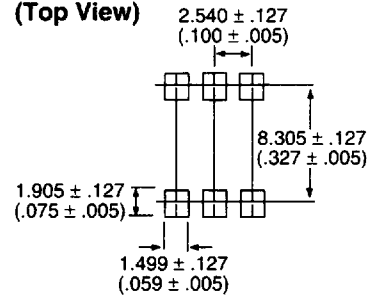

8 Pin Through Hole (Standard)

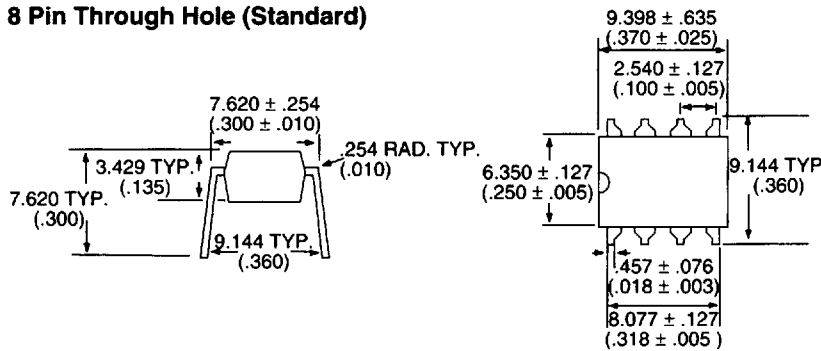

8 Pin PC Board Pattern (Bottom View)

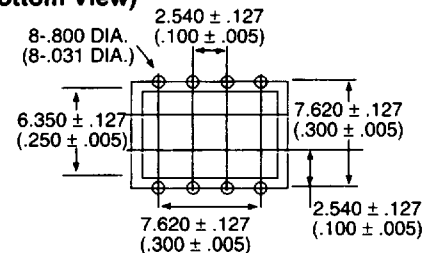

8 Pin Surface Mount ("S" Suffix)

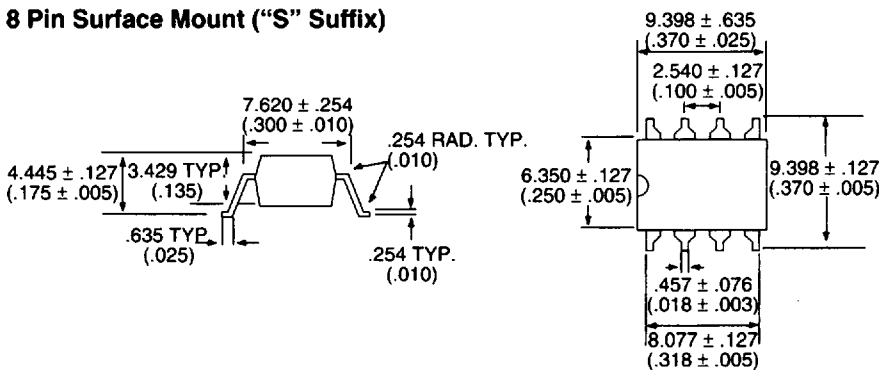

8 Pin Mounting Pad (Top View)

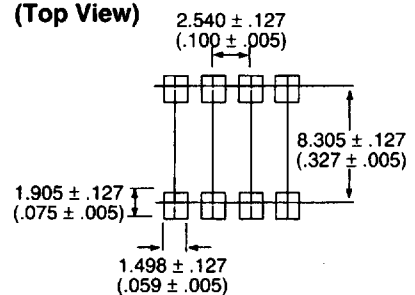

DIMENSIONS
mm
(Inches)

8 Pin Flatpack ("P" Suffix)

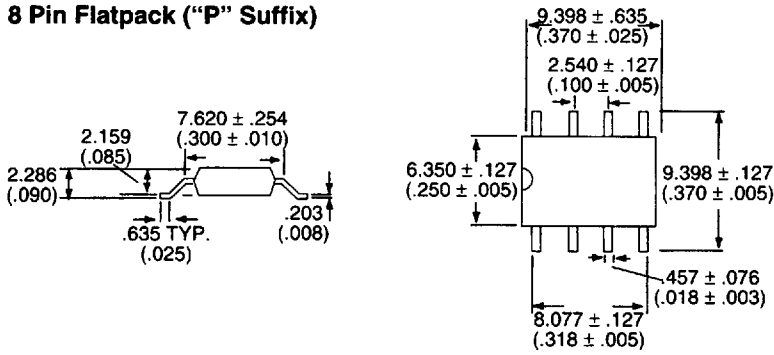

8 Pin Flatpack Mounting Pad (Top View)

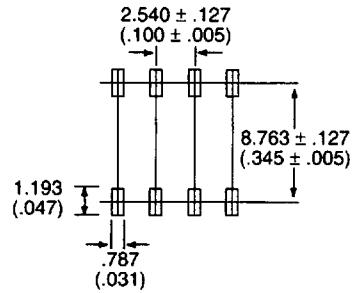

16 Pin SOIC ("P" Suffix)

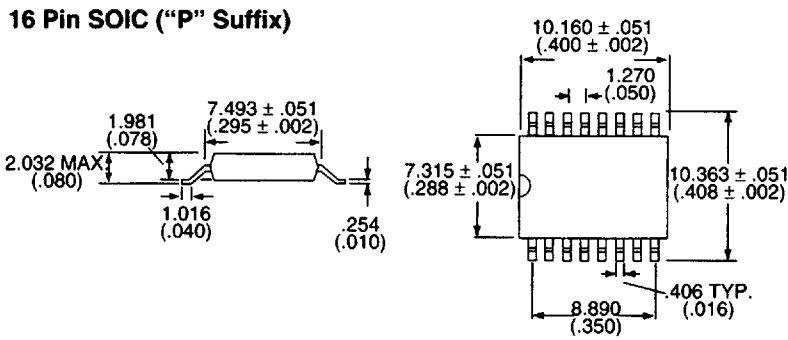

16 Pin SOIC Mounting Pad (Top View)

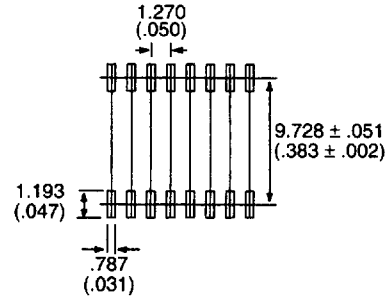

16 Pin Through Hole (Standard)

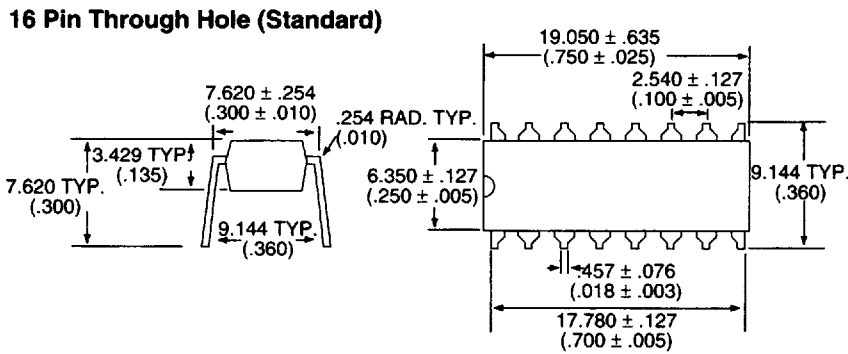

16 Pin PC Board Pattern (Bottom View)

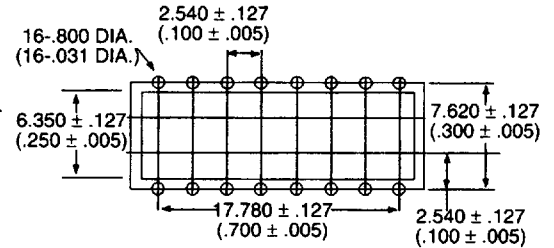

8 Pin SIP

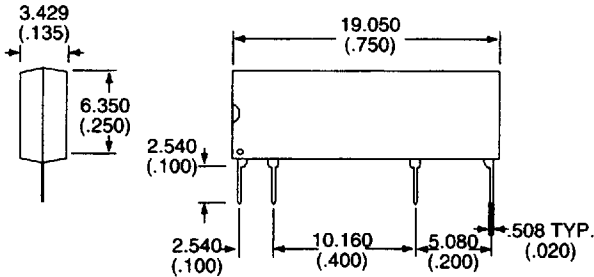

DIMENSIONS
mm
(Inches)

16 Pin DIP

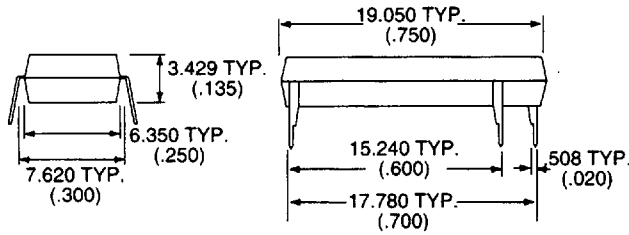

Thermal Clip

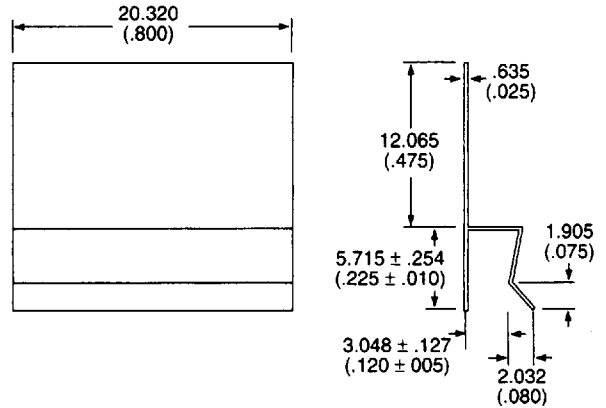

OptoFILM® 10A Series, Pins

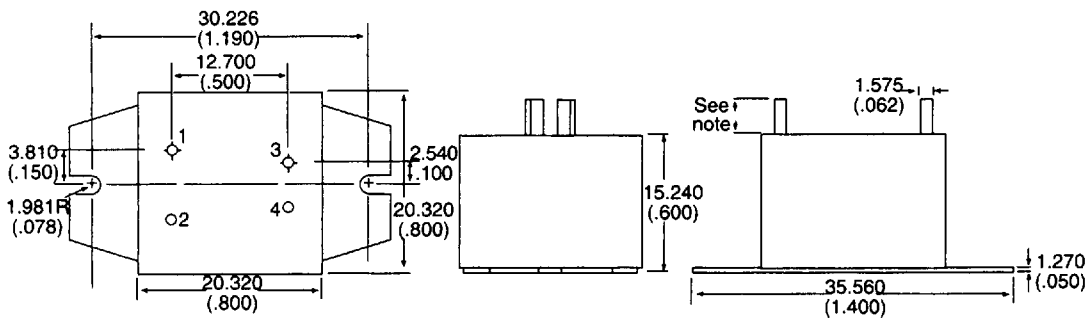

Note: Specify "-1" (0.300" pins)
 Specify "-3" (0.175" pins)

OptoFILM® 10A Series, Quick Connect

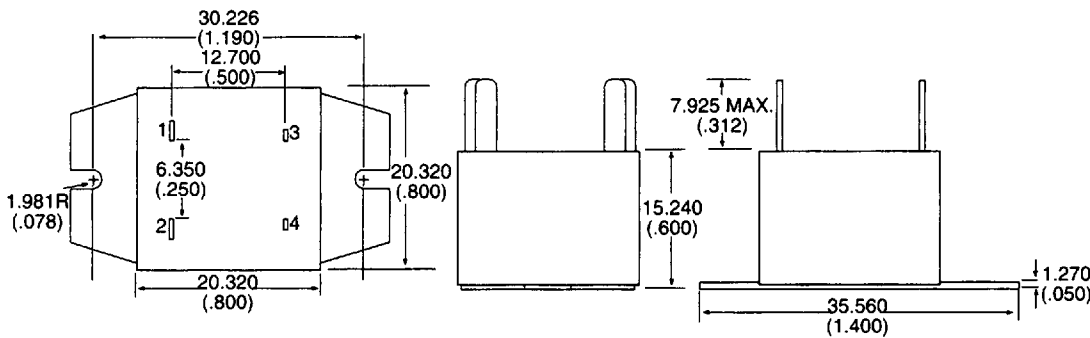

Tape and Reel Packaging for 6 Pin Surface Mount Package

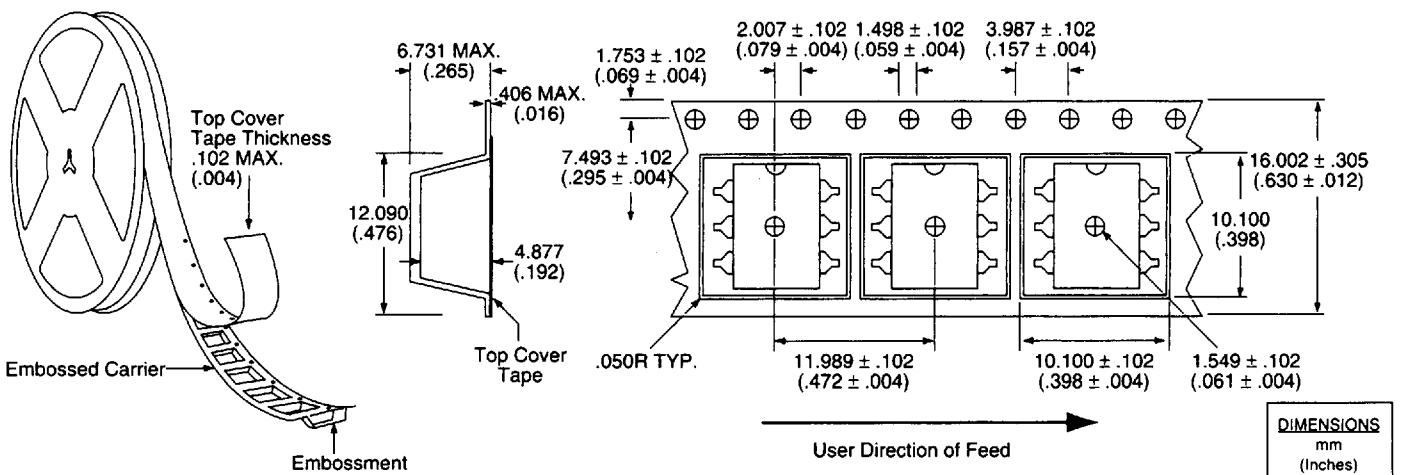

Tape and Reel Packaging for 8 Pin Surface Mount Package

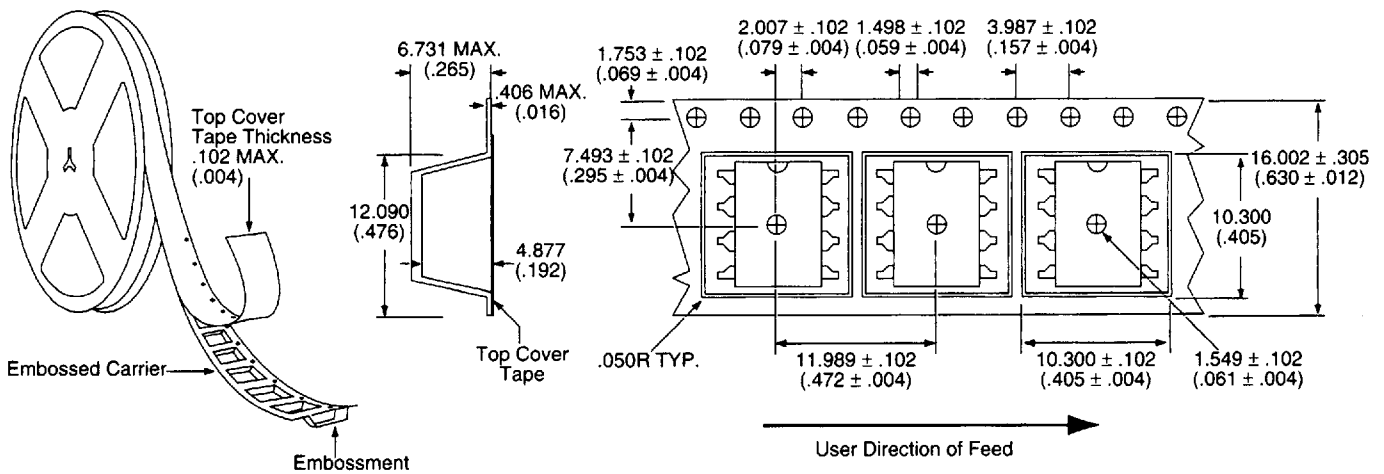

Tape and Reel Packaging for 8 Pin Flatpack Package

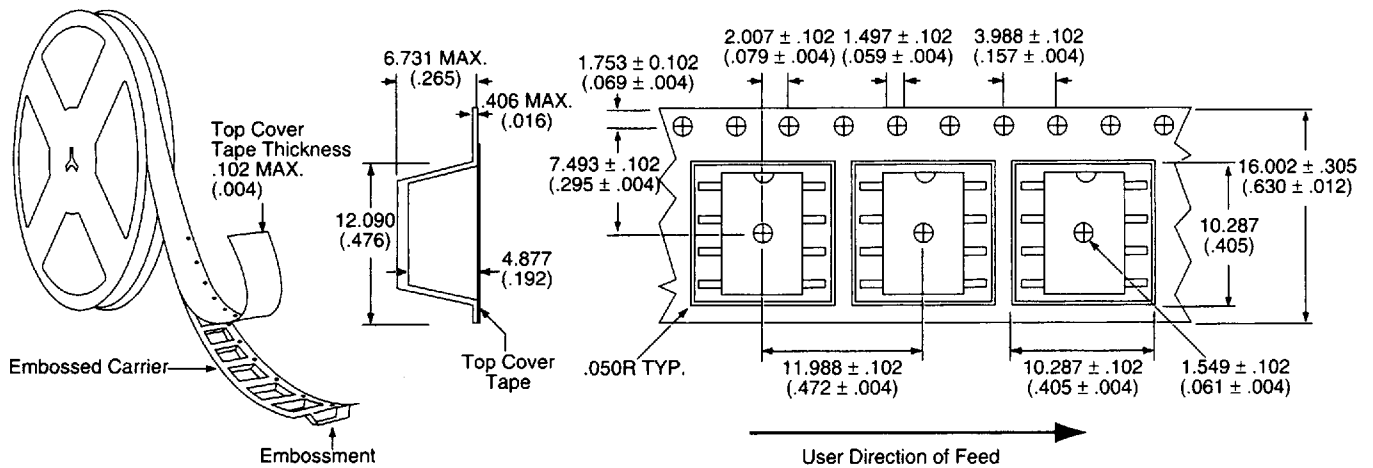

Tape and Reel Packaging for 16 Pin SOIC Package

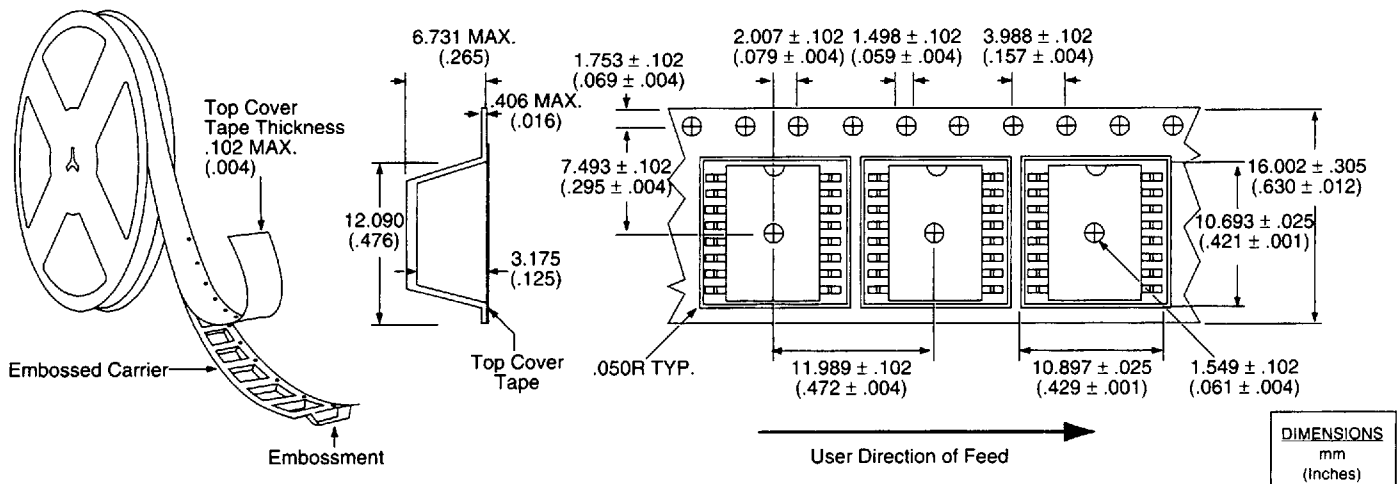

DIMENSIONS
mm
(Inches)