

FEATURES

- 8-bit flash A/D converter
- 20MHz sampling rate
- 10MHz full-power bandwidth
- Sample-hold not required
- Low power CMOS
- +5Vdc operation
- 1.2 Micron CMOS
- 8-Bit latched outputs
- Surface-mount version
- No missing codes

PRODUCT OVERVIEW

The ADC-208A utilizes an advanced VLSI 1.2 micron CMOS in providing 20MHz sampling rates at 8-bits. The flexibility of the design architecture and process delivers latch-up free operation without external components and operation over the full military range.

The ADC-208A is mechanically and electrically equivalent to the ADC-208 Series, with the exception of the OVERFLOW (pin 13) and ENABLE (pins 11 and 12) functions. These functions are not offered on the ADC-208A.

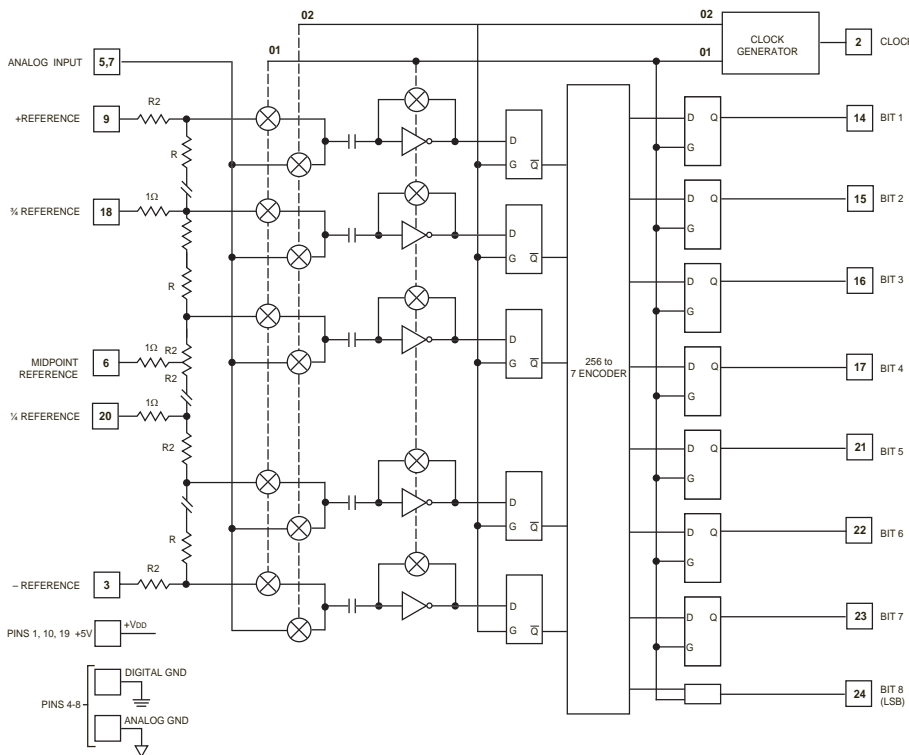

Figure 1. ADC-208A Block Diagram

INPUT/OUTPUT CONNECTIONS			
Pin	FUNCTION	Pin	FUNCTION
1	VDD	24	BIT 8 (LSB)
2	CLOCK INPUT	23	BIT 7
3	-REFERENCE	22	BIT 6
4	ANA/DIG GND (VSS)	21	BIT 5
5	ANALOG INPUT	20	REF 1/4 FS
6	REF MIDPOINT	19	VDD
7	ANALOG INPUT	18	REF 3/4 FS
8	ANA/DIG GND (VSS)	17	BIT 4
9	+REFERENCE	16	BIT 3
10	VDD	15	BIT 2
11	N.C.	14	BIT 1 (MSB)
12	N.C.	13	N.C.

ABSOLUTE MAXIMUM RATINGS		
PARAMETERS	LIMITS	UNITS
Power Supply Voltage (V_{DD} Pin 1, 10, 19)	-0.5 to +7	Volts
Digital Inputs	-0.5 to +5.5	Volts
Analog Input	-0.5 to ($+V_{DD} + 0.5$)	Volts
Reference Inputs	-0.5 to $+V_{DD}$	Volts
Digital Outputs (short circuit protected to ground)	-0.5 to +5.5	Volts
Lead Temperature (10 sec. max.)	+300	°C
Storage Temperature	-65 to +150	°C

FUNCTIONAL SPECIFICATIONS

(Typical at +5V power, +25°C, 20MHz clock, +REFERENCE = +5V,
-REFERENCE = ground, unless noted)

ANALOG INPUT	MIN.	TYP.	MAX.	UNITS
Single-Ended, Non-Isolated Input Range DC - 20MHz	0	-	+5.0	Volts
Analog Input Capacitance				
(static - Pin 5 to 7)	-	20	-	pF
(dynamic - Pin 5 to 7)	-	64	-	pF
Reference Ladder Resistance	-	500	-	Ohms
Reference Input (Note 5)	-0.5	-	$V_{DD} + 0.5$	Volts
DIGITAL INPUTS				
Logic Levels				
Logic "1"	3.2	-	-	Volts
Logic "0"	-	-	0.8	Volts
Logic Loading				
Logic Loading "1"	-	+1	+5	µA
Logic Loading "0"	-	+1	+5	µA
Clock Low Pulse Width	15	25	-	nSec
DIGITAL OUTPUTS				
Logic Levels				
Logic "1"	2.4	4.5	5.0	Volts
Logic "0"	-	-	0.4	Volts
Logic Loading				
Logic Loading "1"	4	-	-	mA
Logic Loading "0"	4	-	-	mA
Output Data Valid Delay From				
Rising Clock Edge				
99% probability	5	10	15	nSec
100% probability				
+25°C	5	10	25	nSec
-55°C to +125°C	-	-	40	nSec
Data Output Resolution	8	-	-	Bits
Data Coding	Straight binary			
PERFORMANCE				
Sampling Rate ②	15	20	-	MSPS
Full Power Bandwidth	10	-	-	MHz
Diff. Linearity @ +25°C (See tech note 7)				
Code Transitions	-	±0.5	±1.0	LSB
Center of Codes	-	±0.25	-	LSB
Diff. Linearity Over Temp.				
Code Transitions	-	±0.5	±1.0	LSB
Center of Codes	-	±0.25	-	LSB
Int. Linearity @ +25°C (See tech note 4)(ref. adjusted)				
End-point	-	-	±1/2	LSB
Best-fit Line	-	-	±1/2	LSB
Int. Linearity Over Temp. (ref. adjusted)				
Best-fit Line	-	±1/2	±1	LSB

PERFORMANCE	MIN.	TYP.	MAX.	UNITS
Int. Linearity @ +25°C (ref. unadjusted)				
End-point	-	±2	±2.6	LSB
Best-fit Line	-	±1.6	±1.9	LSB
Int. Linearity Over Temp. (ref. unadjusted)				
End-point	-	±2.3	±2.6	LSB
Best-fit Line	-	±1.8	±2.0	LSB
Zero-Scale Offset	-	±1	±2	LSB
(Code "0" to "1" transition)				
Gain Error	-	±1.5	±3	LSB
Differential Gain ③	-	2	-	%
Differential Phase ③	-	1.1	-	degrees
Aperture Delay	-	8	-	ns
Aperture Jitter	-	50	-	ps
Harmonic Distortion (8MHz second order harm.)				
	-40	-46	-	dB
Ref. bandwidth (See tech note 5)	-	10	-	MHz
Power Supply Rejection	-	±0.02	±0.05	%FSR/%Vs
No Missing Codes	Over the operating temperature range			
POWER REQUIREMENTS				
Power Supply Range (+V _{DD})	+3.0	+5.0	+5.5	Volts
Power Supply Current				
+25°C	-	+45	+65	mA
+85°C	-	+40	+60	mA
-40°C	-	+50	+70	mA
+125°C	-	+40	+60	mA
-55°C	-	+50	+70	mA
Power Dissipation				
+25°C	-	225	325	mW
+85°C	-	200	300	mW
-40°C	-	250	350	mW
+125°C	-	200	300	mW
-55°C	-	250	350	mW
PHYSICAL/ENVIRONMENTAL				
Operating Temp. Range, Case:				
MC/LC Versions	0	-	+70	°C
MC-C/LC-C Versions	0	-	+70	°C
ME/LE Versions	-40	-	+100	°C
ME-C/LE-C Versions	-40	-	+100	°C
MM/LM/QL Versions	-55	-	+125	°C
MM-C/LM-C/QL-C Versions	-55	-	+125	°C
Storage Temp. Range	-65	-	+150	°C
Package Type				
DIP 24-pin ceramic DIP				
LCC 24-pin ceramic LCC				

Footnotes:

- ① Maximum input impedance is a function of clock frequency.
- ② At full-power input.
- ③ For 10-step, 40 IRE NTSC ramp test.

TECHNICAL NOTES

1. The Reference ladder is floating with respect to VDD and may be referenced anywhere within the specified limits. AC modulation of the reference voltage may also be utilized; contact DATEL for further information.
2. Clock Pulse Width – To improve performance when input signals may exceed Nyquist bandwidths, the clock duty cycle can be adjusted so that the low portion (sample mode) of the clock pulse is 15nSec wide. Reducing the sampling time period minimizes the amount the input voltage slews and prevents the comparators from saturating.
3. A full-scale input produces all "1" on the data outputs.
4. DATEL uses the conservative definitions when specifying Integral Linearity (end-point) and Differential Linearity (code transition). The specifications using the less conservative definition have also been provided as a comparative specification for products specified this way.
5. The process that is used to fabricate the ADC-208A eliminates the latchup phenomena that has plagued CMOS devices in the past. These converters do not require external protection diodes.
6. For clock rates less than 100kHz, there may be some degradation in offset and differential nonlinearity. Performance may be improved by increasing the clock duty cycle (decreasing the time spent in the sample mode).
7. Connect the converter appropriately; a typical connection circuit is shown in Figure 2. Then apply an appropriate clock input. The reference input should be held to $\pm 0.1\%$ accuracy or better. Do not use the +5V power supply as a reference without precision regulation and high-frequency decoupling capacitors.
8. Zero Adjustment - Adjusting the voltage at -REFERENCE (pin 3) adjusts the offset or zero of the device. Pin 3 can be tied to GROUND for operation without adjustments
9. Full Scale Adjustment - Adjusting the voltage at +REFERENCE (pin 9) adjusts the gain of the device. Pin 9 can be tied directly to a +5V reference for operation without adjustment.
10. Integral Nonlinearity Adjustments - Provision is made for optional adjustment of Integral Nonlinearity through access of the reference's $\frac{1}{4}$, $\frac{1}{2}$, and $\frac{3}{4}$ full scale points. For example, the REF. MIDPOINT (pin 6) can be tied to a precision voltage halfway between +REFERENCE and -REFERENCE. Pins 6, 18 and 20 should be bypassed to GROUND through 0.1 μ F capacitors for operation without INL adjustments

Table 1. ADC-208A Output Code

ANALOG INPUT	CODE	DATA 1234	DATA 5678	DECIMAL	HEX
0.00V	Zero 0000	0000	0000	0	00
+0.02V	+1 LSB	0000	0001	1	01
+1.28V	+ $\frac{1}{4}$ FS	0100	0000	64	40
+2.54V	+ $\frac{1}{2}$ FS-ILSB	0111	1111	127	7F
+2.56V	+ $\frac{1}{2}$ FS	1000	0000	128	80
+2.58V	+ $\frac{1}{2}$ FS+ILSB	1000	0001	129	81
+3.84V	+ $\frac{3}{4}$ FS	1100	0000	192	C0
+5.10V	+FS	1111	1111	255	FF

Note: Values shown here are for a +5.12Vdc reference. Scale other references proportionally. (+REF=+5.12V, -REF=GND, $\frac{1}{4}$, $\frac{1}{2}$, and $\frac{3}{4}$ References FS=No Connection)

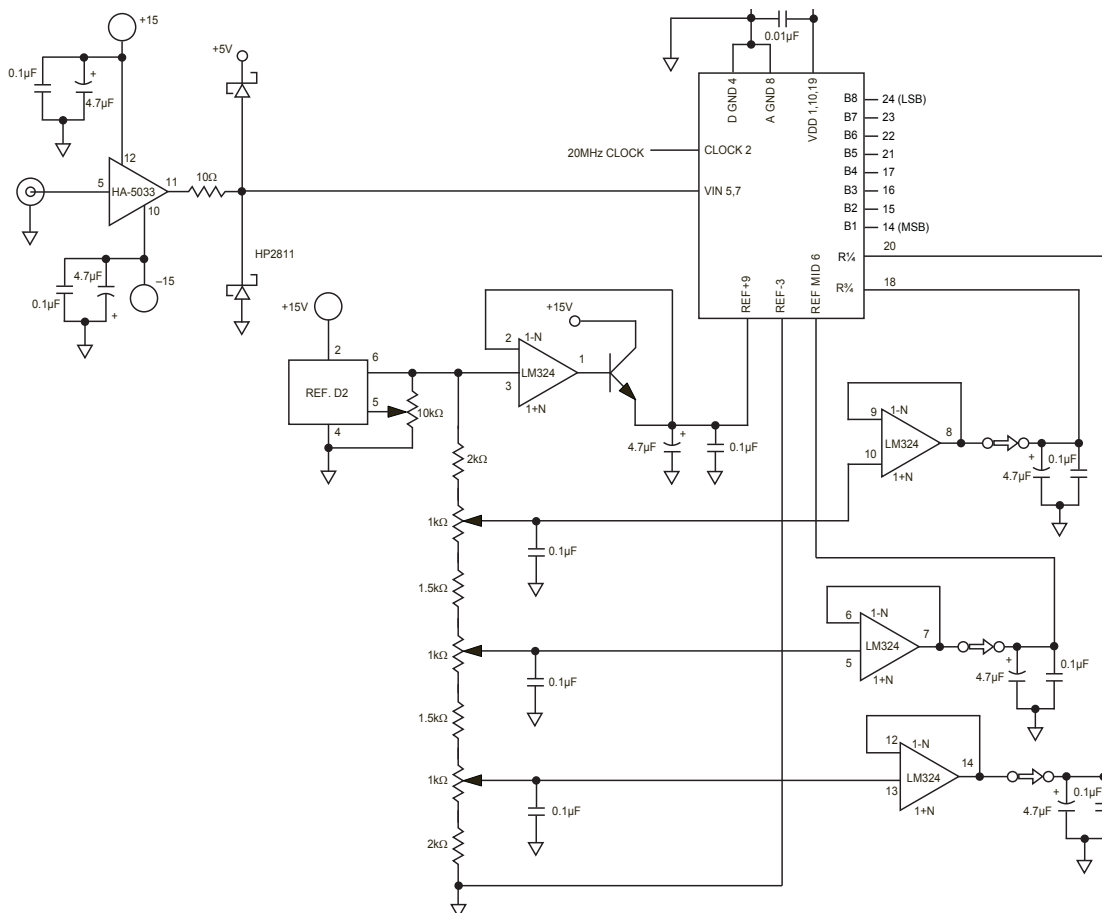

Figure 2. ADC-208A Typical Connection Diagram

MECHANICAL DIMENSIONS

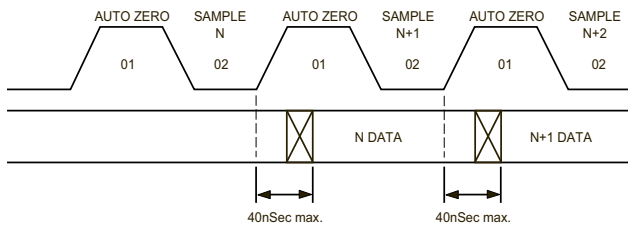
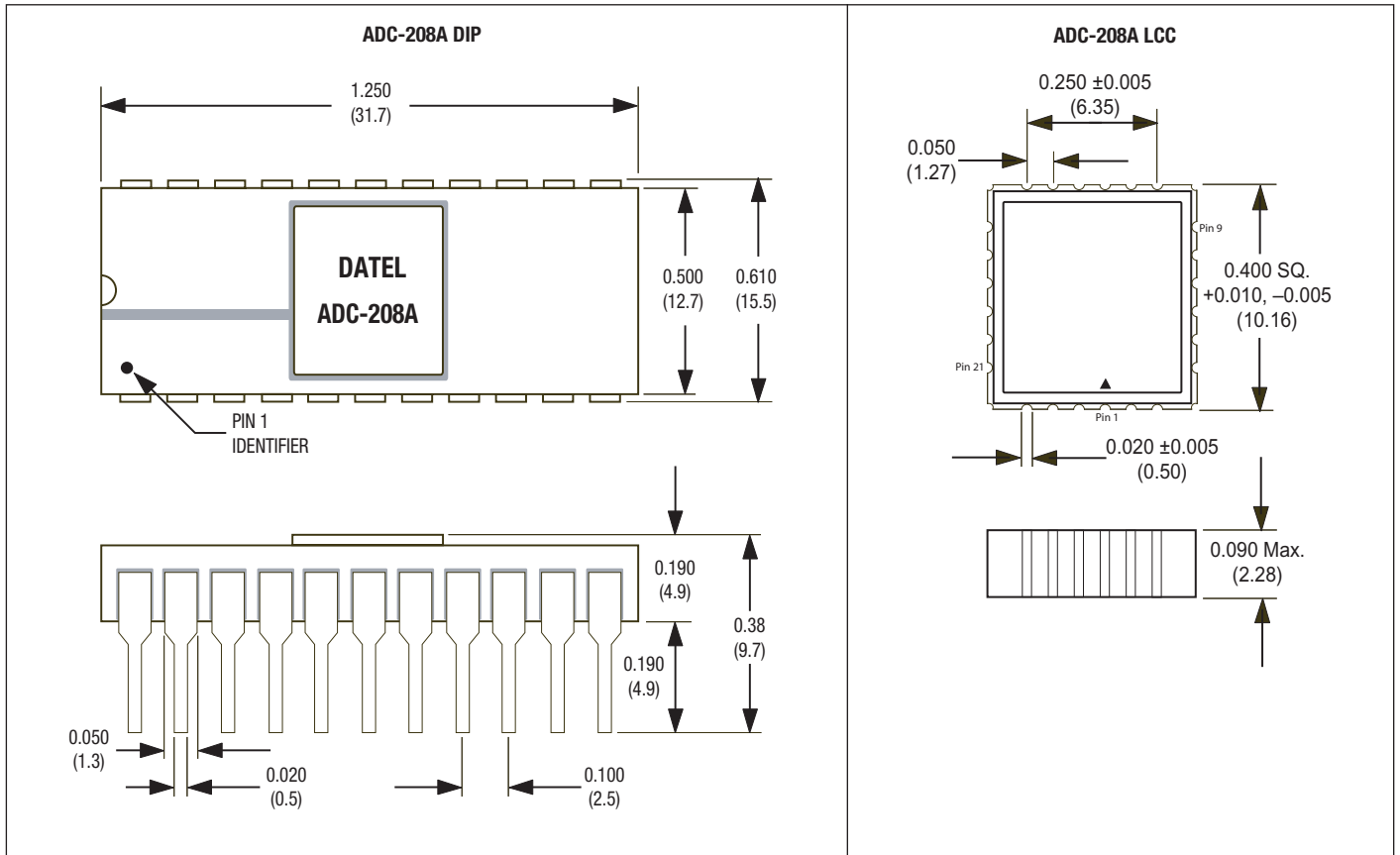

Figure 3. Timing Diagram

ORDERING INFORMATION

MODEL	TEMP. RANGE	PACKAGE	ROHS
ADC-208AMC	0°C to +70°C	24-pin DIP	No
ADC-208AMC-C	0°C to +70°C	24-pin DIP	Yes
ADC-208AME	-40°C to +100°C	24-pin DIP	No
ADC-208AME-C	-40°C to +100°C	24-pin DIP	Yes
ADC-208AMM	-55°C to +125°C	24-pin DIP	No
ADC-208AMM-C	-55°C to +125°C	24-pin DIP	Yes
ADC-208AMM-QL	-55°C to +125°C	24-pin DIP	No
ADC-208AMM-QL-C	-55°C to +125°C	24-pin DIP	Yes
ADC-208ALC	0°C to +70°C	24-pin LCC	No
ADC-208ALC-C	0°C to +70°C	24-pin LCC	Yes
ADC-208ALE	-40°C to +100°C	24-pin LCC	No
ADC-208ALE-C	-40°C to +100°C	24-pin LCC	Yes
ADC-208ALM	-55°C to +125°C	24-pin LCC	No
ADC-208ALM-C	-55°C to +125°C	24-pin LCC	Yes
ADC-208ALM-QL	-55°C to +125°C	24-pin LCC	No
ADC-208ALM-QL-C	-55°C to +125°C	24-pin LCC	Yes

DATEL is a registered trademark of
Murata Power Solutions, Inc.
11 Cabot Boulevard, Mansfield, MA 02048-1151 USA
ITAR and ISO 9001/14001 REGISTERED

Murata Power Solutions, Inc. makes no representation that the use of its products in the circuits described herein, or the use of other technical information contained herein, will not infringe upon existing or future patent rights. The descriptions contained herein do not imply the granting of licenses to make, use, or sell equipment constructed in accordance therewith. Specifications are subject to change without notice.

© 2013 Murata Power Solutions, Inc.

www.datel.com • e-mail: help@datel.com