

\*RoHS COMPLIANT

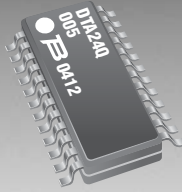

**BOURNS®**

## Features

- Lead free
- RoHS compliant\*
- 18 termination channels
- Incorporates 36 bidirectional Schottky-based diodes
- Small form factor replaces 18 SOT23 packages



Model 2DTA is currently available, although not recommended for new designs.

- Low forward voltage (2 options available)
- Very fast recovery time

## Thin Film on Silicon 2DTA High Performance Memory Bus Terminator

### General Information

The Model 2DTA Series High Performance Memory Bus Terminator is well-suited for high speed bus termination applications where variable bus loading and very low terminator power dissipation are required. This very efficient high speed terminator array is highly integrated and is very effective for use in space constrained applications such as PC notebooks and motherboards, engineering workstations and portable battery powered devices. Two performance options are available. The higher grade 2DTA-5 with a maximum forward voltage of 0.75 V is suited for ultra-fast and dense memory termination configurations. The 2DTA-10, with a maximum specified forward voltage of 0.85 V is primarily targeted to general purpose applications where board space is critical.

### Package Schematic

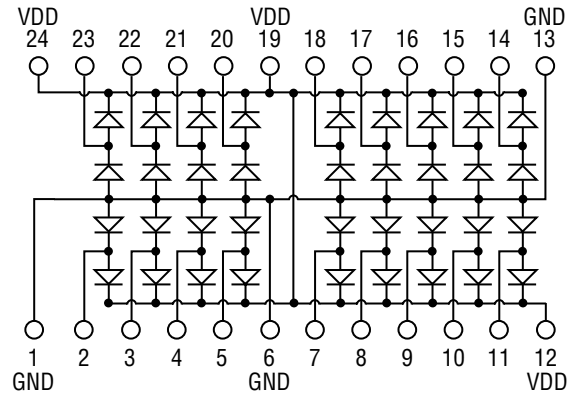

### Electrical & Environmental Characteristics

Electrical Characteristics	Symbol	Minimum	Nominal	Maximum	Unit
V <sub>DD</sub>		-0.3		+7	V
Channel Clamp Current (continuous)	I <sub>C</sub>			±50	mA
2DTA-5 Forward Voltage:					
@I <sub>f</sub> = 16 mA	V <sub>f</sub>		0.4	0.65	V
@I <sub>f</sub> = 50 mA	V <sub>f</sub>		0.5	0.75	V
2DTA-10 Forward Voltage:					
@I <sub>f</sub> = 16 mA	V <sub>f</sub>		0.5	0.75	V
@I <sub>f</sub> = 50 mA	V <sub>f</sub>		0.65	0.85	V
Leakage Current @ Max. V <sub>DD</sub>			0.1	5	μA
Diode Capacitance				5	pF
Diode Ohmic Resistance				5	Ω
Charge Carrier Lifetime	t <sub>l</sub>		100		pS
<b>Environmental Characteristics</b>					
ESD Protection (Mil-Std-883 Method 3015)		4			KV
Operating Temperature	T <sub>J</sub>	-55		+125	°C
Storage Temperature	T <sub>stg</sub>	-65		+150	°C
Diode Power Rating			20		mW/diode

\*RoHS Directive 2002/95/EC Jan 27 2003 including Annex

Specifications are subject to change without notice.

Customers should verify actual device performance in their specific applications.

## Applications

- High speed synchronous DRAM, SGRAM, SyncLink memory bus termination
- High speed SRAM cache
- 100 MHz PCI and AGP bus termination
- Local bus termination for all popular microprocessors

## Thin Film on Silicon 2DTA High Performance Memory Bus Terminator

**BOURNS®**

### Mechanical Characteristics

#### QSOP Package Dimensions

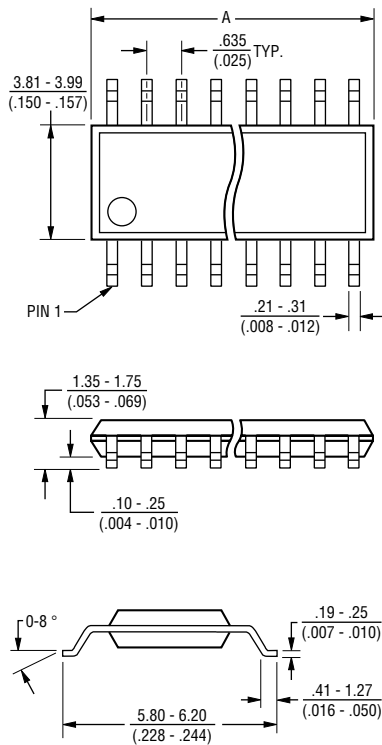

Model	A
2QSP24	8.56 - 8.74 (.337 - .344)

Governing dimensions are in mm. Dimensions in parentheses are in inches and are approximate.

JEDEC Reference Number MO-137.

#### QSOP Package Power Temperature Derating Curve

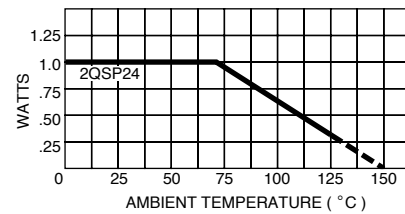

#### Typical Part Marking

Represents total content. Layout may vary.

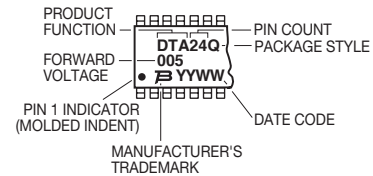

# Thin Film on Silicon 2DTA High Performance Memory Bus Terminator



## Dispensing

For large quantities, the product will be dispensed in Tape and Reel (see diagram below).

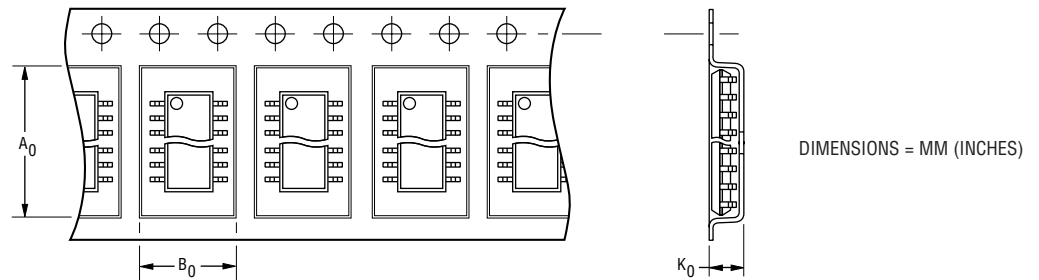

DIMENSIONS = MM (INCHES)

Package	A <sub>0</sub>	B <sub>0</sub>	K <sub>0</sub>	Width	Pitch	No. of Pieces per 13 reel	No. of Pieces per tube
QSOP 24 Pin	6.5 (0.256)	9.0 (0.354)	2.1 (0.083)	16 (0.630)	8 (0.315)	3,500	56

## How To Order

**2 DTA-5 - Q 24 R LF**

**Product Class** ———— Thin-Film-on-Silicon

**Product Function** ———— DTA = Memory Bus Terminator

**Forward Voltage (V<sub>f</sub>)** ———— (See Electrical Characteristics)

**Standard Package Style** ———— Q = QSOP

**Pin Count** ———— Q = 24

**Dispensing** ———— R = Reel T = Tube

**Terminations** ———— LF = 100 % Sn (lead free)



*Reliable Electronic Solutions*

**Asia-Pacific:**

Tel: +886-2 2562-4117 • Fax: +886-2 2562-4116

**Europe:**

Tel: +41-41 768 5555 • Fax: +41-41 768 5510

**The Americas:**

Tel: +1-951 781-5500 • Fax: +1-951 781-5700

[www.bourns.com](http://www.bourns.com)