

SANYO**LC75395E****Single-Chip Electronic Volume Control System****Overview**

The LC75395E is an electronic volume control that provides volume, balance, five-band equalization and input switching functions. These functions are controlled from serial input data.

Functions

Volume control: The volume control provides 25 attenuation positions: from 0 dB to 17.5 dB in 1.25 dB steps, from 17.5 dB to 25 dB in 2.5 dB steps, from 25 dB to 36.25 dB in 3.75 dB steps and with settings for 41.25 dB, 50 dB, 60 dB and ∞ .

A balance function can be implemented by controlling the left and right channels independently.

Equalizer: The equalizer function supports ± 10 dB control in 2 dB steps in each of the five bands. Of the five bands, four provide peaking characteristics, and one provides shelving characteristics.

Selector: The selector function selects one of four inputs for each of the left and right channels. An arbitrary amplification level can be set for each input signal using external components.

Serial data input: All controls can be set from serial input data (CCB format)

Package Dimensions

unit: mm

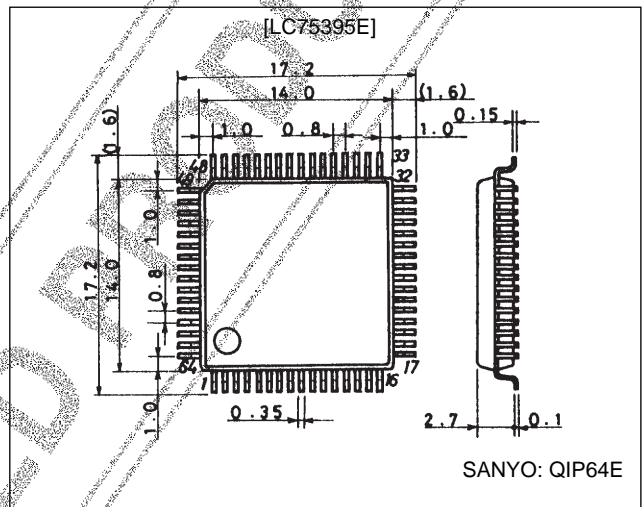
3159-QFP64E**Features**

On-chip buffer amplifiers to minimize the number of external components

Silicon-gate CMOS process for minimal switching noise

On-chip circuit to generate the $V_{DD}/2$ reference voltage

CCB is a trademark of SANYO ELECTRIC CO., LTD.
CCB is SANYO's original bus format and all the bus addresses are controlled by SANYO.

Specifications**Absolute Maximum Ratings at $T_a = 25$ C, $V_{SS} = 0$ V**

Parameter	Symbol	Conditions	Ratings	Unit
Maximum supply voltage	V_{DD} max	V_{DD}	12	V
Maximum input voltage	V_{IN} max	CL, DI, CE, L1 to L4, R1 to R4, LTIN, RTIN, LVRIN, RVRIN	$V_{SS} - 0.3$ to $V_{DD} + 0.3$	V
Allowable power dissipation	P_d max	$T_a \leq 85^\circ\text{C}$	310	mW
Operating temperature	T_{opr}		-30 to +85	$^\circ\text{C}$
Storage temperature	T_{stg}		-40 to +125	$^\circ\text{C}$

SANYO Electric Co.,Ltd. Semiconductor Business Headquarters

TOKYO OFFICE Tokyo Bldg., 1-10, 1 Chome, Ueno, Taito-ku, TOKYO, 110 JAPAN

LC75395E

Allowable Operating Ranges at $T_a = 25\text{ C}$, $V_{SS} = 0\text{ V}$

Parameter	Symbol	Conditions	min	typ	max	Unit
Supply voltage	V_{DD}	V_{DD}	6.0		11.0	V
Input high level voltage	V_{IH}	CL, DI, CE	4.0		V_{DD}	V
Input low level voltage	V_{IL}	CL, DI, CE	V_{SS}		1.0	V
Input voltage amplitude	V_{IN}	CL, DI, CE, L1 to L4, R1 to R4, LTIN, RTIN, LVRIN, RVRIN	V_{SS}		V_{DD}	Vp-p
Input pulse width	$t_{\theta W}$	CL	1.0			μs
Setup time	t_{SETUP}	CL, DI, CE	1.0			μs
Hold time	t_{HOLD}	CL, DI, CE	1.0			μs
Operating frequency	fopg	CL			500	kHz

Electrical Characteristics at $T_a = 25\text{ C}$, $V_{DD} = 10\text{ V}$, $V_{SS} = 0\text{ V}$

Parameter	Symbol	Conditions	min	typ	max	Unit
[Input Block]						
Input resistance	R_{in}	L1 to L4, R1 to R4		1		$M\Omega$
Clipping level	V_{cl}	LSELO, RSELO: THD = 1.0%		2.65		Vrms
Output load resistance	R_L	LSELO, RSELO	3			$k\Omega$
[Volume Control Block]						
Input resistance	R_{in}	LVRIN, RVRIN	21	35	49	$k\Omega$
[Equalizer Control Block]						
Control range	G_{eq}	Max, boost/cut	± 8	± 10	± 12	dB
Step resolution	E_{step}		1	2	3	dB
Internal feedback resistance	R_{feed}		17	28	39	$k\Omega$
[Overall Characteristics]						
Total harmonic distortion	THD (1)	$V_{IN} = 1\text{ Vrms}$, $f = 1\text{ kHz}$, with all controls flat overall		0.0033		%
	THD (2)	$V_{IN} = 1\text{ Vrms}$, $f = 20\text{ kHz}$, with all controls flat overall		0.012		%
Crosstalk	CT	$V_{IN} = 1\text{ Vrms}$, $f = 1\text{ kHz}$, with all controls flat overall $R_g \leq 1\text{ k}\Omega$		86		dB
Output at maximum attenuation	$V_{O\ min}$	$V_{IN} = 1\text{ Vrms}$, $f = 1\text{ kHz}$, with the main volume control at \rightarrow		-84		dB
Output noise voltage	$V_N(1)$	With all controls flat overall (IHF-A), $R_g = 1\text{ k}\Omega$		3.9		μV
	$V_N(2)$	With all controls flat overall (DIN-AUDIO), $R_g = 1\text{ k}\Omega$		5.4		μV
Current drain	I_{DD}	$V_{DD} - V_{SS} = 11\text{ V}$		25	33	mA
Input high level current	I_{IH}	CL, DI, CE: $V_{IN} = 11\text{ V}$			10	μA
Input low level current	I_{IL}	CL, DI, CE: $V_{IN} = 0\text{ V}$	-10			μA

Input Amplifier Characteristics at $T_a = 25\text{ C}$, $V_{DD} = 10\text{ V}$, $V_{SS} = 0\text{ V}$

Parameter	Symbol	Conditions	min	typ	max	Unit
Input offset voltage	V_{IO}		-10		+10	mV
Input offset current	I_{IO}	$V_{SS} \leq V_{IN} \leq V_{DD}$		± 10		nA
Open-loop voltage gain	A_O			80		dB
0 dB bandwidth	f_T			2.5		MHz
Allowable load resistance	R_L		3			$k\Omega$

Equivalent Circuit Block Diagram and Sample Application Circuit

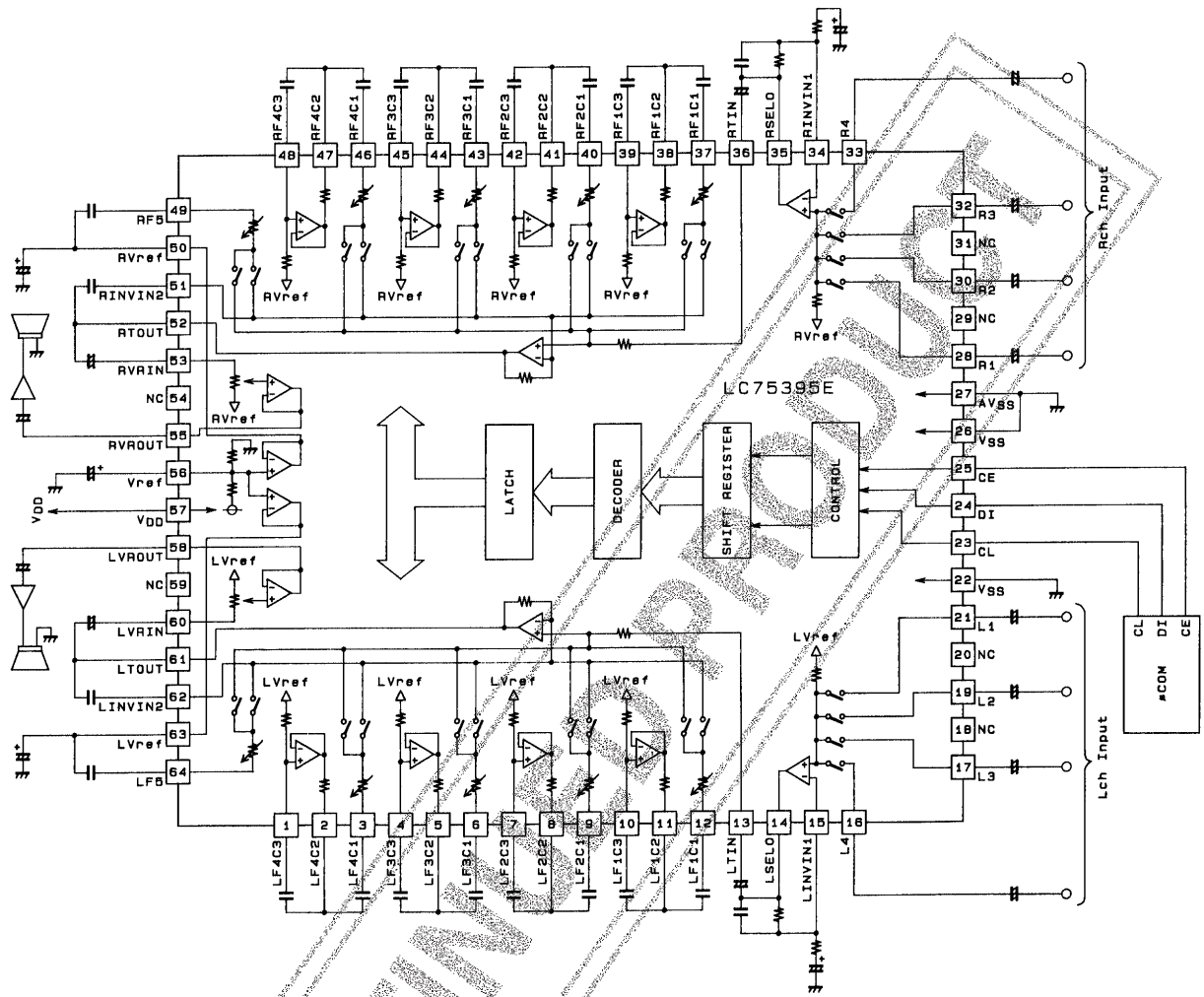

A03544

Note: If at all possible, use bipolar capacitors for all capacitors that do not have a polarity specified.

DISCONTINUED

LC75395E

Test Circuits

1. Total Harmonic Distortion

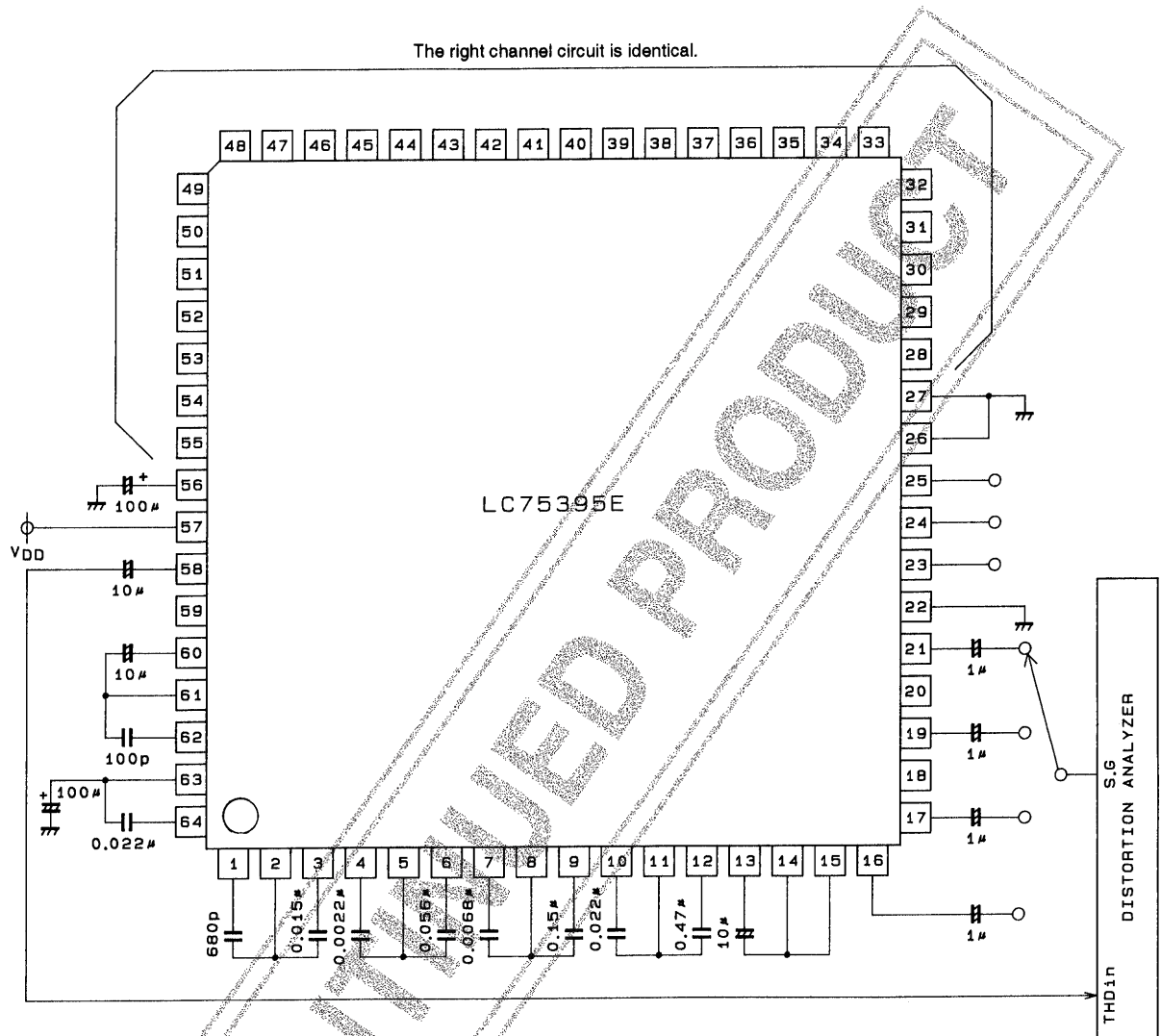

A03545

Unit (capacitance: F)

LC75395E

Test Circuits

2. Output Noise Voltage

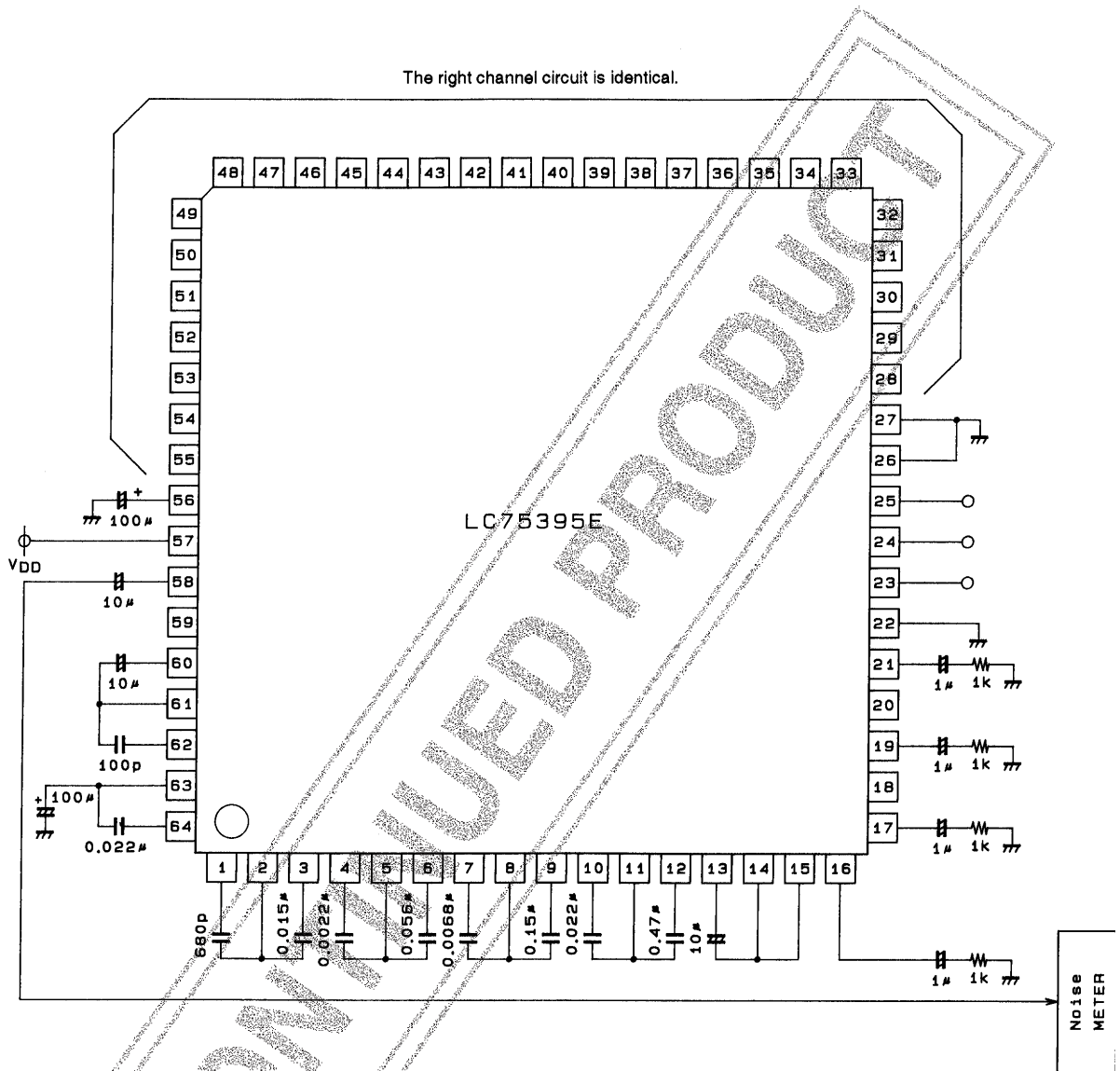

A03546

Unit (resistance: Ω , capacitance: F)

LC75395E

Test Circuits

3. Crosstalk

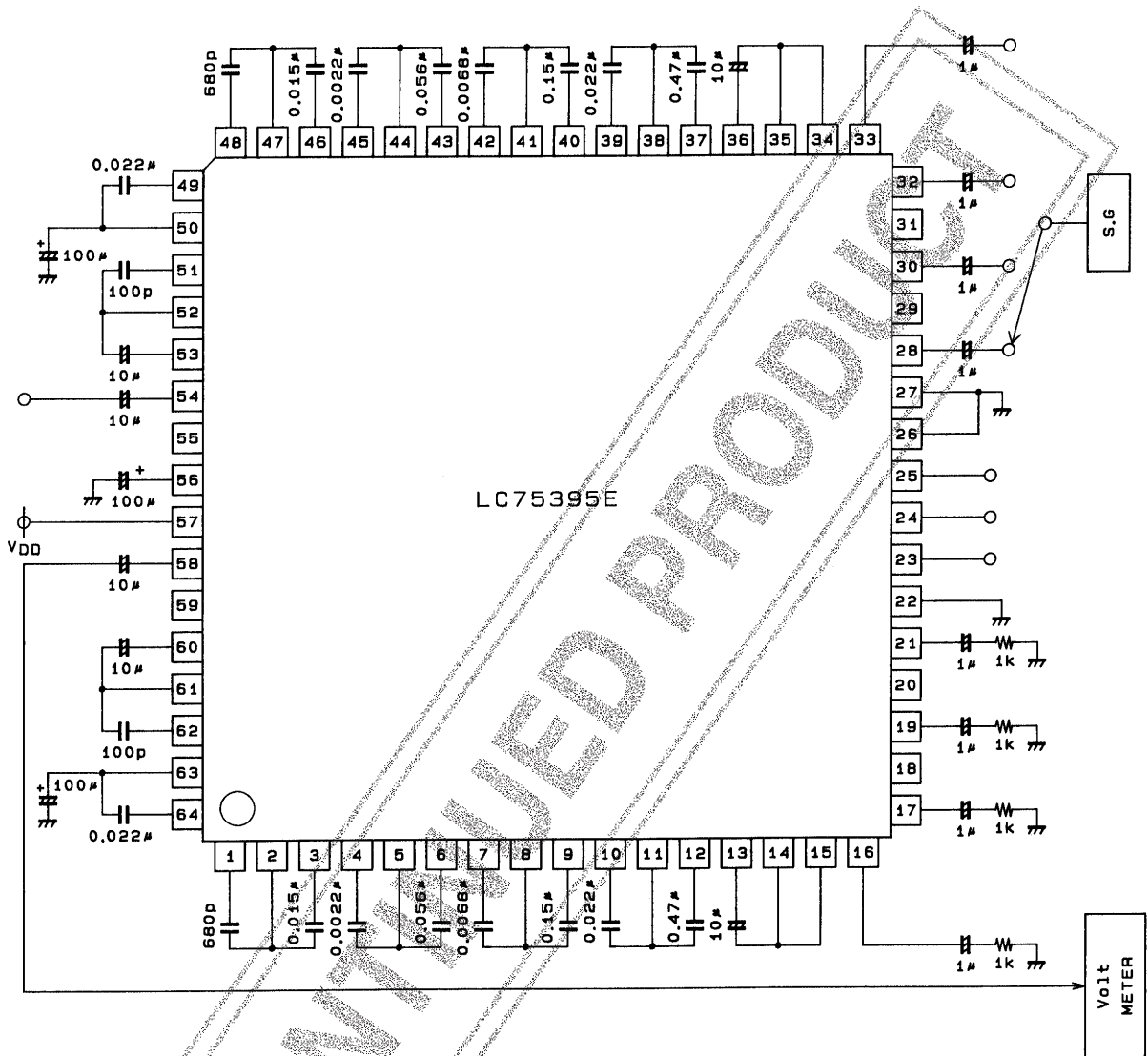

A03547

Unit (resistance: Ω , capacitance: F)

DISCONTINUED PRODUCT

LC75395E

Pin Assignment

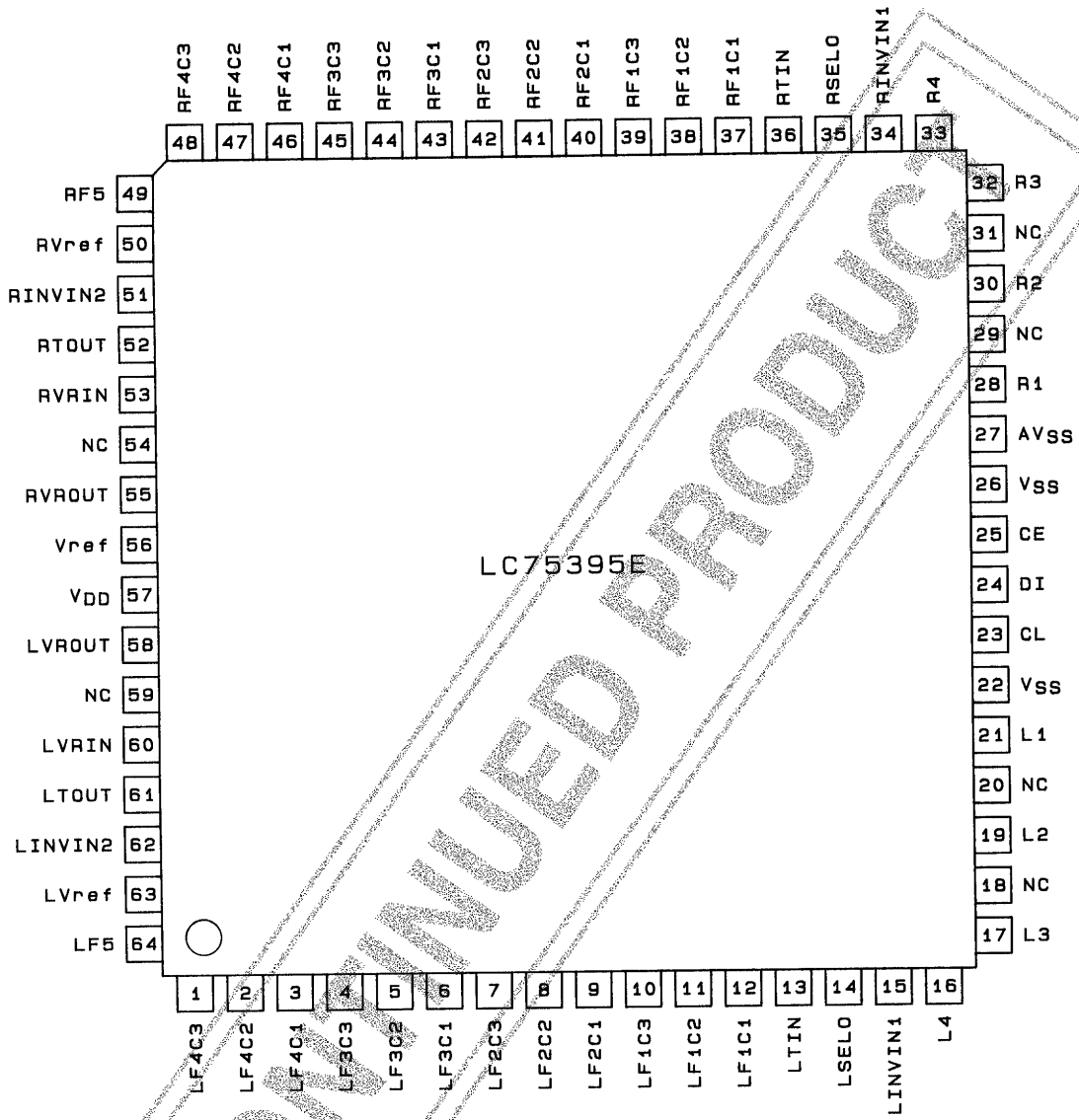

A03548

Top view

Pin Functions

Pin No.	Symbol	Function	Note	
12 11 10	LF1C1 LF1C2 LF1C3	The left channel F1 band control block. These are external capacitor connections.	<p style="text-align: right;">A03549</p>	
37 38 39	RF1C1 RF1C2 RF1C3	The right channel F1 band control block. These are external capacitor connections.		
9 8 7	LF2C1 LF2C2 LF2C3	The left channel F2 band control block. These are external capacitor connections.		
40 41 42	RF2C1 RF2C2 RF2C3	The right channel F2 band control block. These are external capacitor connections.		
6 5 4	LF3C1 LF3C2 LF3C3	The left channel F3 band control block. These are external capacitor connections.		
43 44 45	RF3C1 RF3C2 RF3C3	The right channel F3 band control block. These are external capacitor connections.		
3 2 1	LF4C1 LF4C2 LF4C3	The left channel F4 band control block. These are external capacitor connections.		
46 47 48	RF4C1 RF4C2 RF4C3	The right channel F4 band control block. These are external capacitor connections.		
13 36	LTIN RTIN	Tone control inputs These must be driven by low-impedance circuits.		<p style="text-align: right;">A03550</p>
14 35	LSELO RSELO	Input selector outputs		<p style="text-align: right;">A03551</p>
64 49	LF5 RF5	F5 band control block. These are external capacitor connections.	<p style="text-align: right;">A03552</p>	
21 19 17 16 28 30 32 33	L1 L2 L3 L4 R1 R2 R3 R4	Signal inputs	<p style="text-align: right;">A03553</p>	
57	V _{DD}	Power supply		
22, 26	V _{SS}	Internal logic system ground		
27	AV _{SS}	Internal operational amplifier ground		

Continued on next page.

LC75395E

Continued from preceding page.

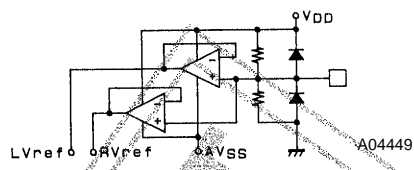
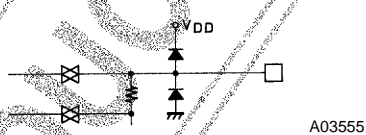
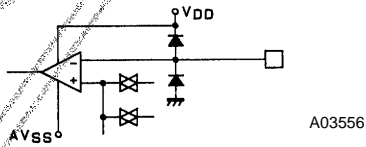
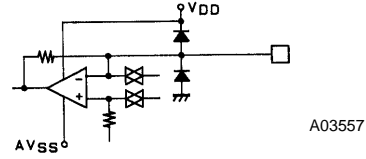
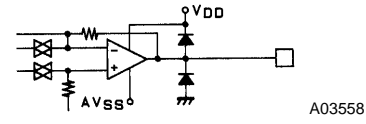
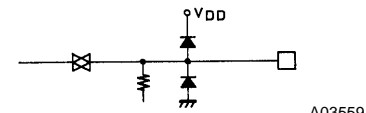
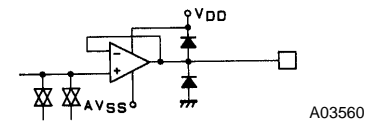
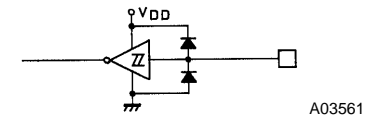
Pin No.	Symbol	Function	Note
56	Vref	$V_{DD}/2$ voltage generation block. A capacitor must be inserted between Vref and V_{SS} to suppress power supply ripple.	 A04449
63 50	LVref RVref	Common pins for the volume control, tone control and input switching blocks. Since capacitors inserted between LVref (or RVref) and V_{SS} become the residual resistance when the volume control is set at maximum attenuation, the values of these capacitors must be chosen carefully. A voltage higher than V_{DD} must never be applied.	 A03555
15 34	LINVIN1 RINVIN1	Inverting inputs for the operational amplifiers that set the input gain.	 A03556
62 51	LINVIN2 RINVIN2	Inverting inputs for the graphic equalizer operational amplifiers. Unnecessary frequency bands can be excluded and oscillation prevented by inserting arbitrary capacitors between the INVIN2 and TOUT pins.	 A03557
61 52	LTOUT RTOUT	Tone control outputs	 A03558
60 53	LVRIN RVRIN	Volume control inputs These must be driven by low-impedance circuits.	 A03559
58 55	LVROUT RVROUT	Volume control outputs	 A03560
25	CE	Chip enable Data is read into the internal latches and the analog switches operate when this pin goes from high to low. Data transfer is enabled when this pin is high.	 A03561
24 23	DI CL	Serial data and clock connections for chip control	
18 20 29 31 54 59	NC NC NC NC NC NC	Unused pins	

Input Block Internal Equivalent Circuit Diagram

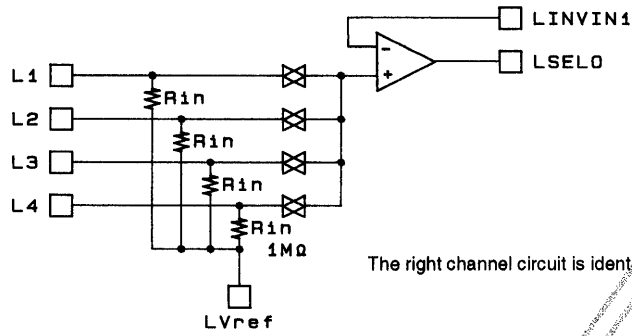

The right channel circuit is identical.

A03562

Volume Control Block Internal Equivalent Circuit Diagram

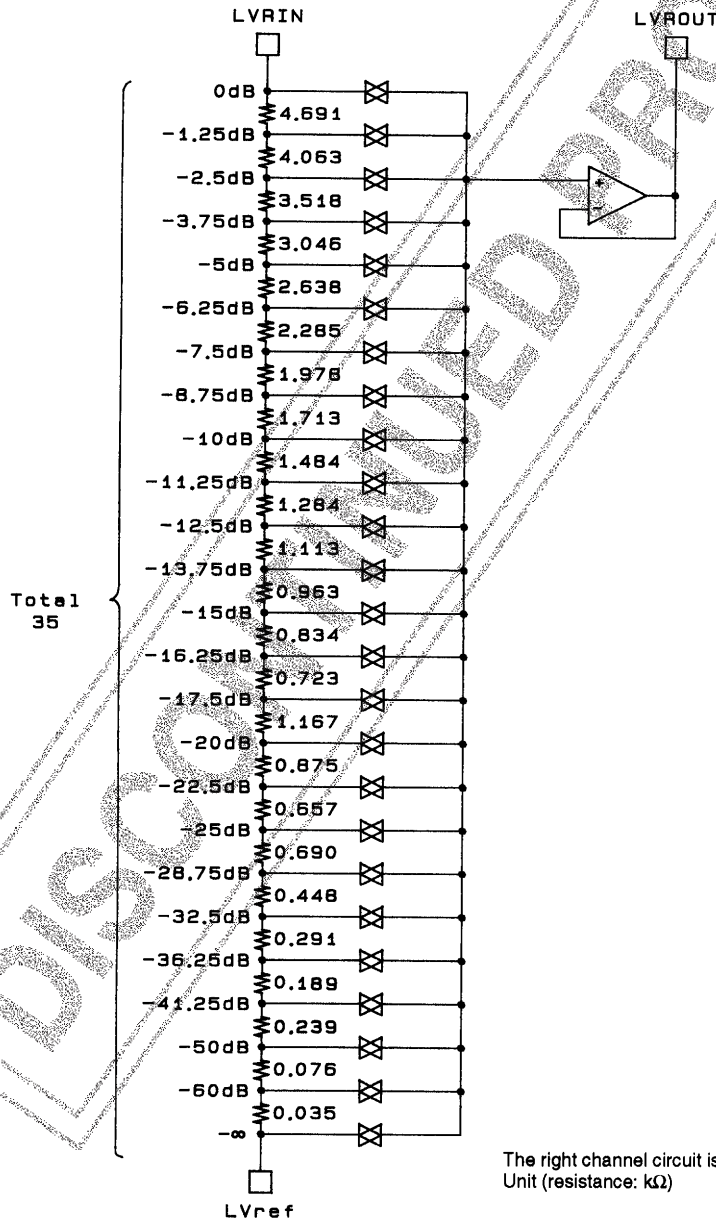

The right channel circuit is identical.
Unit (resistance: kΩ)

A03563

Equalizer Control Block Internal Equivalent Circuit (bands F1 to F4)

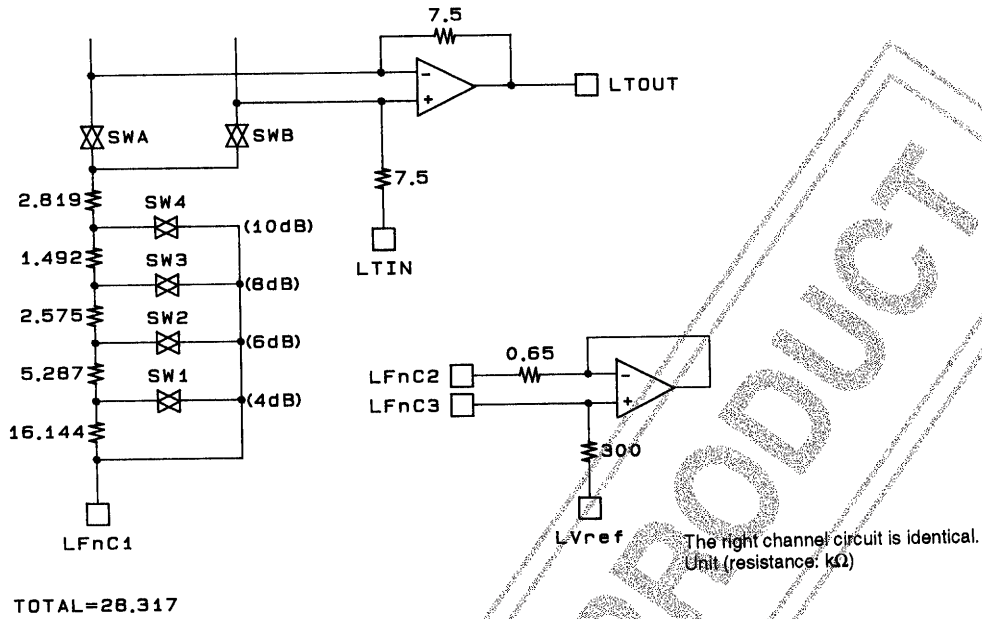

A03564

External Capacitor Calculations

The LC75395E supports four bands with peaking characteristics and one band with shelving characteristics.

1. Peaking Characteristics (bands F1 to F4)

The external capacitor functions as the structural element of a simulated inductor. The equivalent circuit and the calculations required to achieve the desired center frequency are shown below.

Equivalent circuit for the simulated inductor

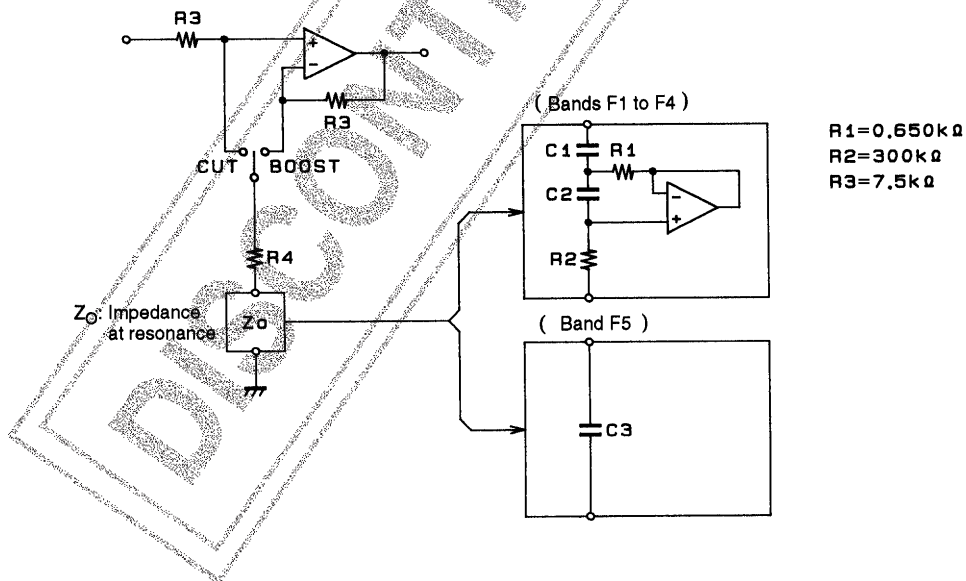

A03565

Sample Calculation

Specifications 1) Center frequency $F_O = 107 \text{ Hz}$ 2) Q at maximum boost: $Q_{+10 \text{ dB}} = 0.8$ ① Derive the sharpness (Q_O) of the simulated inductor itself.

$$Q_O = (R1 + R4)/R1 \times Q_{+10 \text{ dB}} \\ \approx 4.270$$

② Derive C1.

$$C1 = 1/2\pi F_O R1 Q_O \approx 0.536 \text{ } (\mu\text{F})$$

③ Derive C2.

$$C2 = Q_O/2\pi F_O R2 \approx 0.021 \text{ } (\mu\text{F})$$

Sample values for C1 and C2

Center frequency F_O (Hz)	C1 (F)	C2 (F)
107	0.536 μ	0.021 μ
340	0.169 μ	6663 p
1070	0.054 μ	2117 p
3400	0.017 μ	666 p

2. Shelving Characteristics (band F5)

To achieve -10 dB (in 2 dB steps) at the target frequency, use an external capacitor C3 which has an impedance of 650Ω .

Control System Timing and Data Format

The LC75395E is controlled by inputting stipulated data to the CE, CL, and DI pins. The data consists of a total of 40 bits, of which 8 bits are address and 32 bits are data.

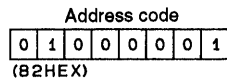
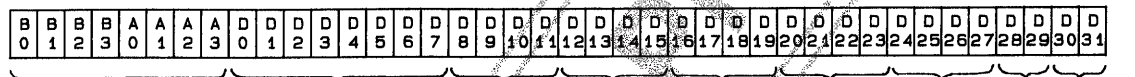
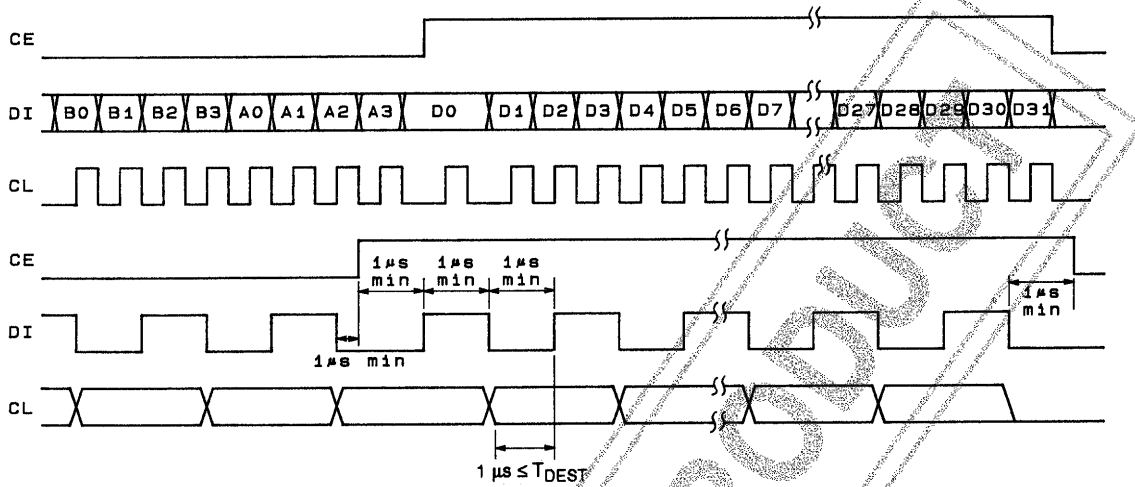

Volume control	Band F5 control	Band F4 control	Band F3 control	Band F2 control	Band F1 control	Input switching control
00000000	1010 +10dB	1010 +10dB	1010 +10dB	1010 +10dB	1010 +10dB	00 L1 (R1)
10000000	0010 +8dB	0010 +8dB	0010 +8dB	0010 +8dB	0010 +8dB	10 L2 (R2)
01000000	1100 +6dB	1100 +6dB	1100 +6dB	1100 +6dB	1100 +6dB	01 L3 (R3)
11000000	0100 +4dB	0100 +4dB	0100 +4dB	0100 +4dB	0100 +4dB	11 L4 (R4)
00100000	1000 +2dB	1000 +2dB	1000 +2dB	1000 +2dB	1000 +2dB	
10100000	0000 0dB	0000 0dB	0000 0dB	0000 0dB	0000 0dB	
01100000	1001 -2dB	1001 -2dB	1001 -2dB	1001 -2dB	1001 -2dB	
11100000	0101 -4dB	0101 -4dB	0101 -4dB	0101 -4dB	0101 -4dB	
00010000	1101 -6dB	1101 -6dB	1101 -6dB	1101 -6dB	1101 -6dB	
10010000	0011 -8dB	0011 -8dB	0011 -8dB	0011 -8dB	0011 -8dB	
01010000	1011 -10dB	1011 -10dB	1011 -10dB	1011 -10dB	1011 -10dB	
11010000						
00110000						
10110000						
01110000						
11110000						
00001000						
10001000						
01001000						
11001000						
00101000						
10101000						
01101000						
11101000						
00011000						
10011000						
01011000						
11011000						
00111000						
10111000						
01111000						
11111000						
00011000						
10011000						
01011000						
11011000						
00111000						
10111000						
01111000						
11111000						
00011000						
10011000						
01011000						
11011000						
00111000						
10111000						
01111000						
11111000						
00011000						
10011000						
01011000						
11011000						
00111000						
10111000						
01111000						
11111000						
00011000						
10011000						
01011000						
11011000						
00111000						
10111000						
01111000						
11111000						
00011000						
10011000						
01011000						
11011000						
00111000						
10111000						
01111000						
11111000						
00011000						
10011000						
01011000						
11011000						
00111000						
10111000						
01111000						
11111000						
00011000						
10011000						
01011000						
11011000						
00111000						
10111000						
01111000						
11111000						
00011000						
10011000						
01011000						
11011000						
00111000						
10111000						
01111000						
11111000						
00011000						
10011000						
01011000						
11011000						
00111000						
10111000						
01111000						
11111000						
00011000						
10011000						
01011000						
11011000						
00111000						
10111000						
01111000						
11111000						
00011000						
10011000						
01011000						
11011000						
00111000						
10111000						
01111000						
11111000						
00011000						
10011000						
01011000						
11011000						
00111000						
10111000						
01111000						
11111000						
00011000						
10011000						
01011000						
11011000						
00111000						
10111000						
01111000						
11111000						
00011000						
10011000						
01011000						
11011000						
00111000						
10111000						
01111000						
11111000						
00011000						
10011000						
01011000						
11011000						
00111000						
10111000						
01111000						
11111000						
00011000						
10011000						
01011000						
11011000						
00111000						
10111000						
01111000						
11111000						
00011000						
10011000						
01011000						
11011000						
00111000						
10111000						
01111000						
11111000						
00011000						
10011000						
01011000						
11011000						
00111000						
10111000						
01111000						
11111000						
00011000						
10011000						
01011000						
11011000						
00111000						
10111000						
01111000						
11111000						
00011000						
10011000						
01011000						
11011000						
00111000						
10111000						
01111000						
11111000						
00011000						
10011000						
01011000						
11011000						
00111000						
10111000						
01111000						
11111000						
00011000						
10011000						
01011000						
11011000						
00111000						
10111000						
01111000						
11111000						
00011000						
10011000						
01011000						
11011000						
00111000						
10111000						
01111000						
11111000						
00011000						
10011000						
01011000						
11011000						
00111000						
10111000						

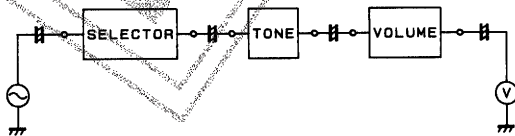
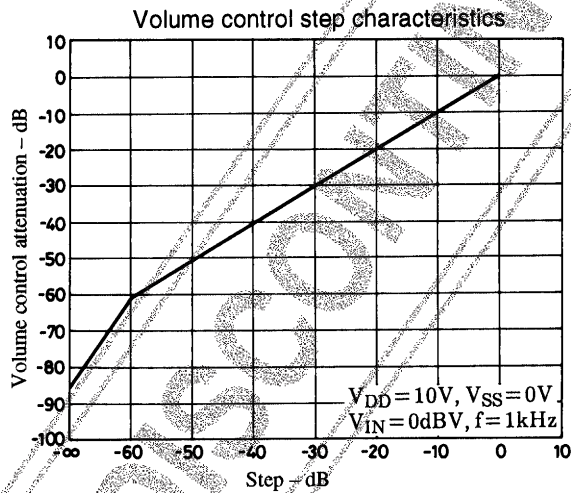
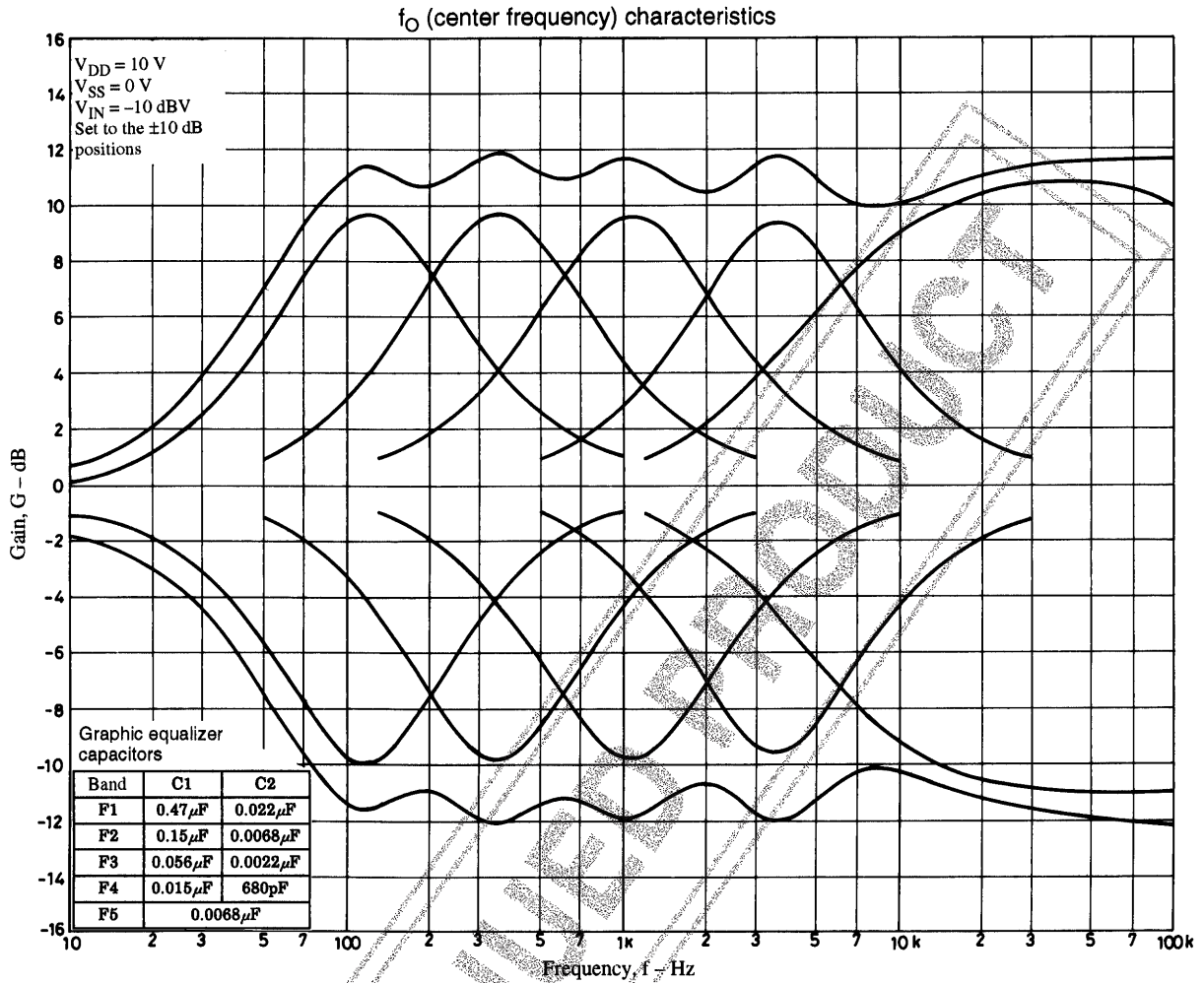

A03730

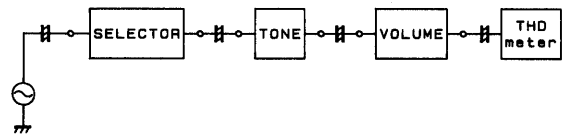
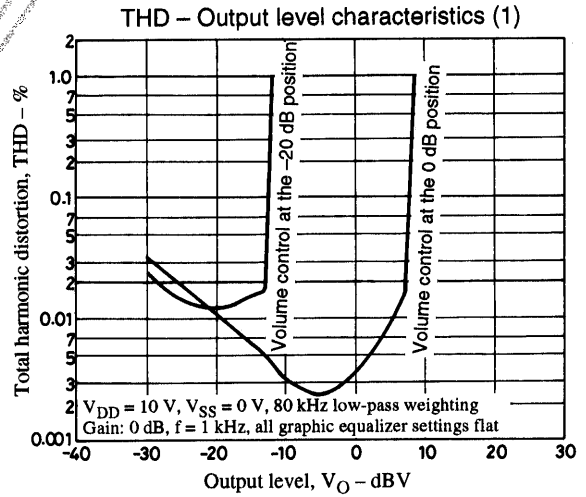

A03731

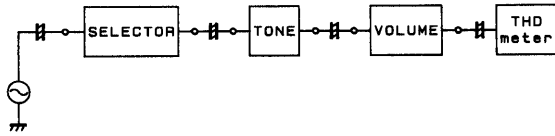
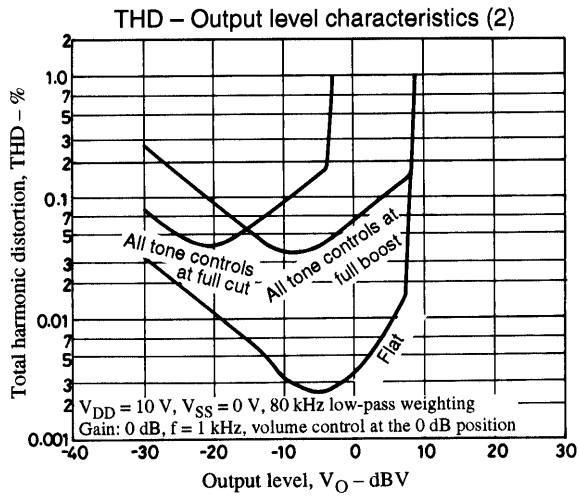

A03732

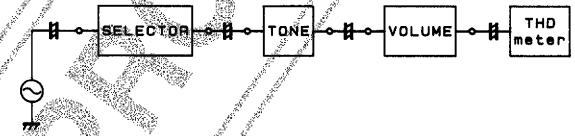
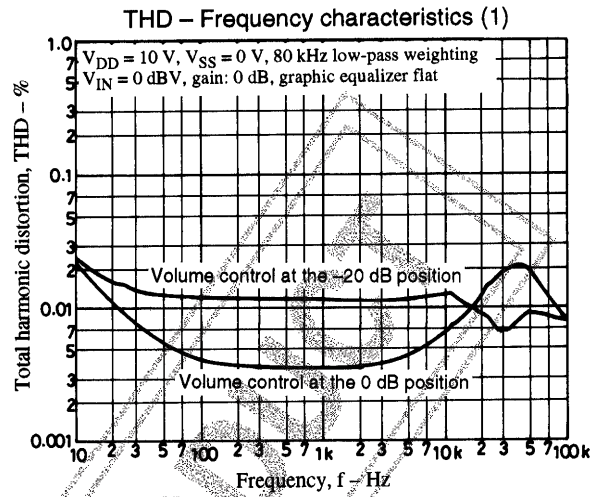

A03733

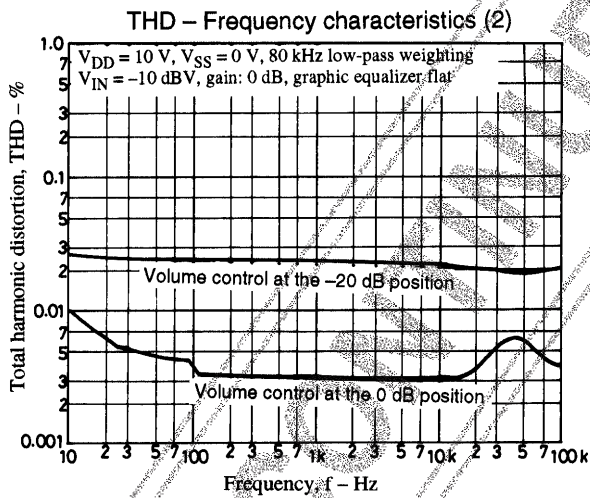

A03734

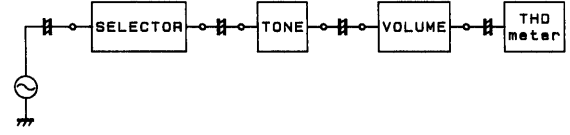
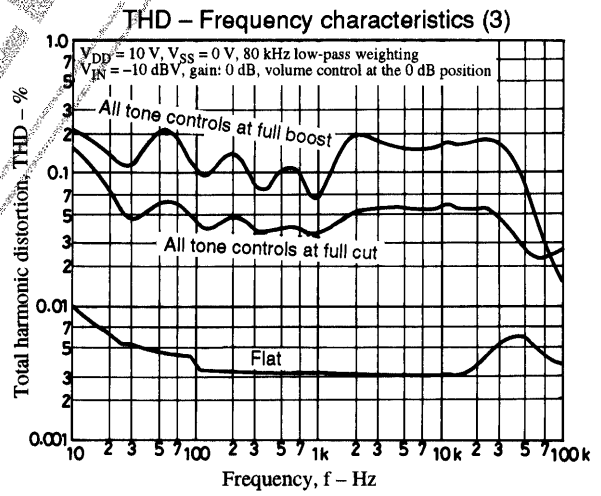

A03735

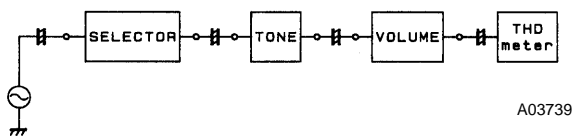
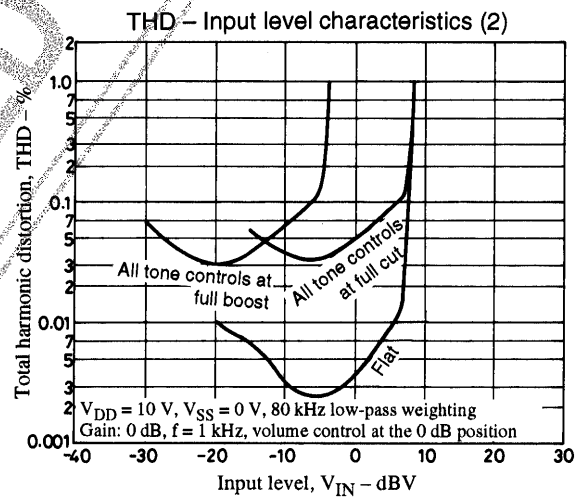
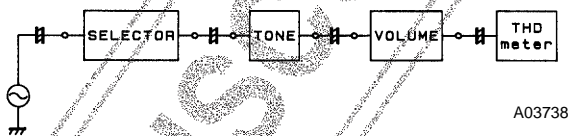
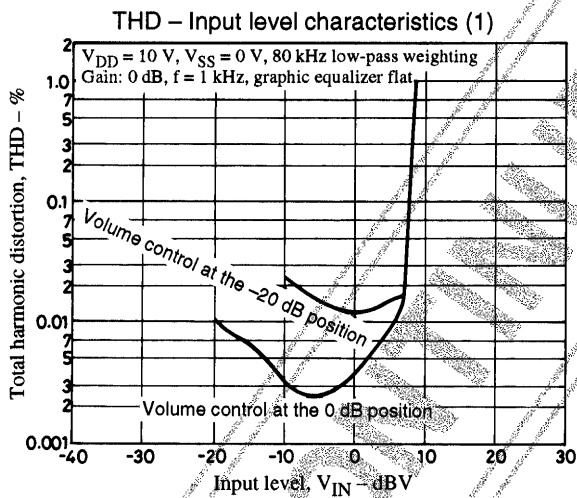
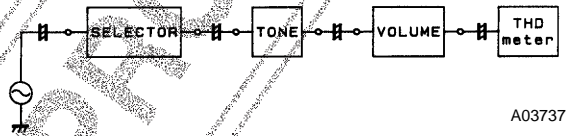
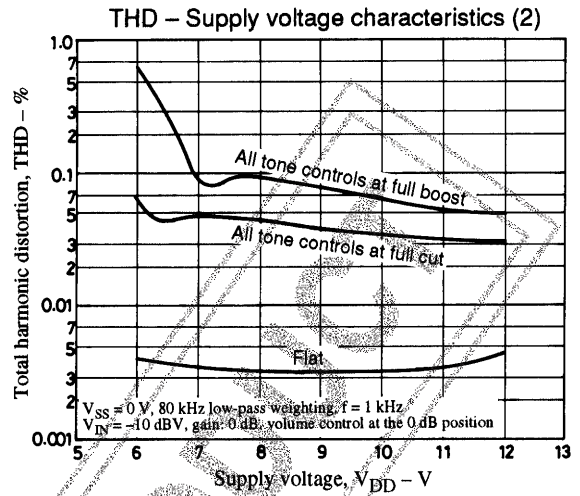
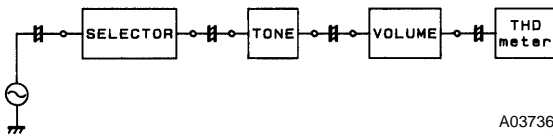
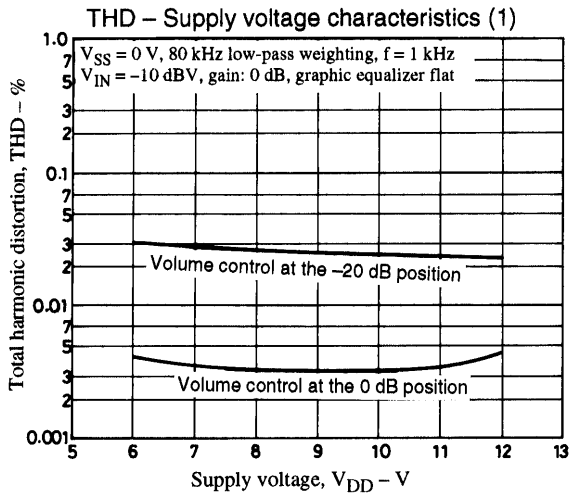

Usage Notes

1. The states of the internal analog switches are undefined when power is first applied. Muting should be applied externally until control data has been transferred and stored.
2. The signal lines for the CL, DI and CE pins should either be covered by the pattern ground or be formed from shielded cable to prevent the high-frequency digital signals transmitted over these lines from entering the analog system.

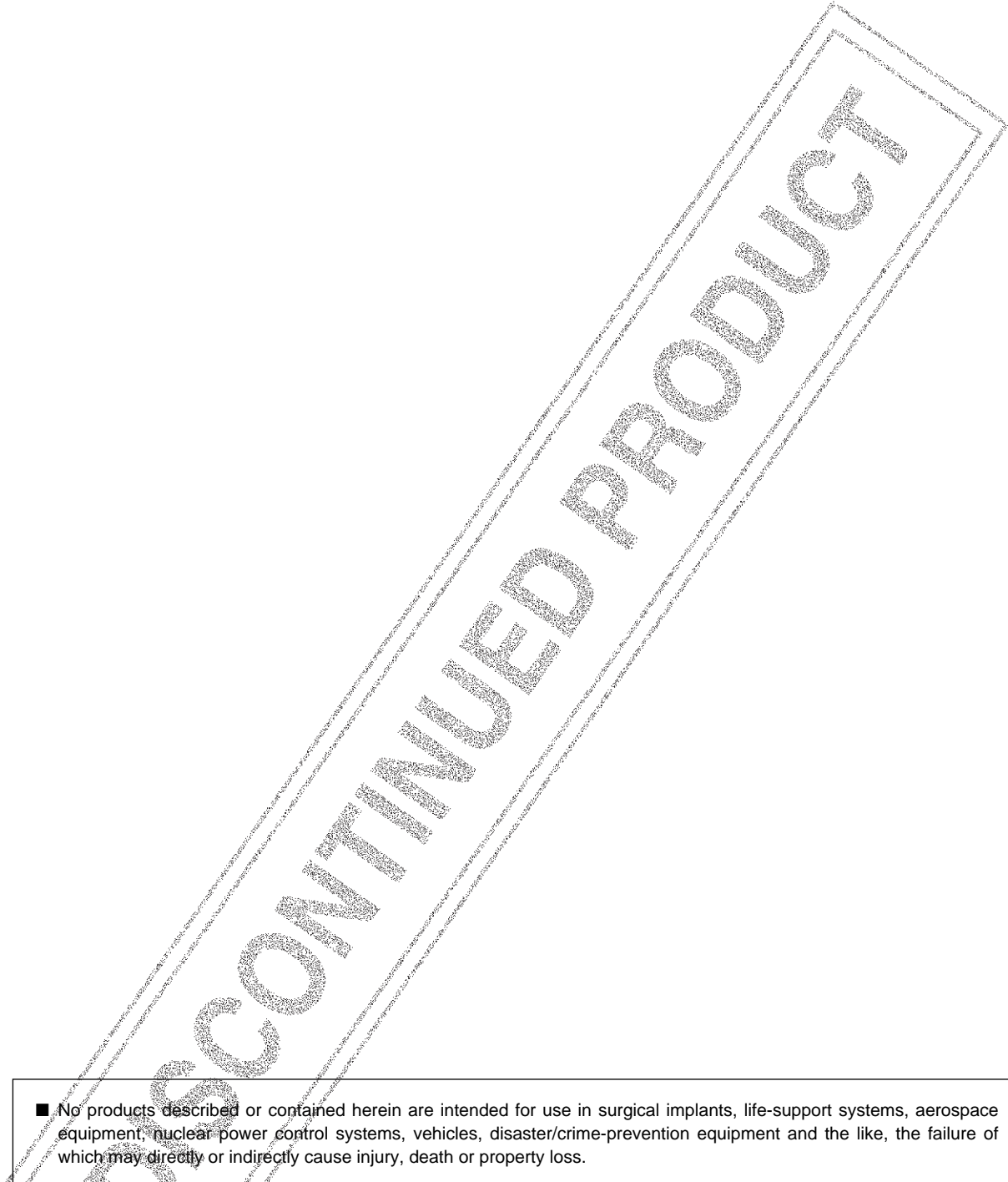
- 
- No products described or contained herein are intended for use in surgical implants, life-support systems, aerospace equipment, nuclear power control systems, vehicles, disaster/crime-prevention equipment and the like, the failure of which may directly or indirectly cause injury, death or property loss.
 - Anyone purchasing any products described or contained herein for an above-mentioned use shall:
 - ① Accept full responsibility and indemnify and defend SANYO ELECTRIC CO., LTD., its affiliates, subsidiaries and distributors and all their officers and employees, jointly and severally, against any and all claims and litigation and all damages, cost and expenses associated with such use:
 - ② Not impose any responsibility for any fault or negligence which may be cited in any such claim or litigation on SANYO ELECTRIC CO., LTD., its affiliates, subsidiaries and distributors or any of their officers and employees jointly or severally.
 - Information (including circuit diagrams and circuit parameters) herein is for example only; it is not guaranteed for volume production. SANYO believes information herein is accurate and reliable, but no guarantees are made or implied regarding its use or any infringements of intellectual property rights or other rights of third parties.

This catalog provides information as of November, 1997. Specifications and information herein are subject to change without notice.