

MC10SX1125

622Mb/s Fiber Optic Post Amplifier

The SX1125 is an integrated limiting amplifier for high frequency fiber optic applications. The device interfaces directly to the trans-impedance amplifier of a typical optical to electrical conversion portion of a fiber optic link. With data rate capabilities in the 622Mb/s range, the high gain limiting amplification of the SX1125 is ideal for high speed fiber optic applications like SONET/SDM, ATM, FDDI, Fibre Channel or Serial Hippi. The device is functionally and pin compatible to the Signetics SA5225 with a significantly higher bandwidth. The C_{AZP} and C_{AZN} inputs to the limiting amplifier provide an auto-zero function to effectively cancel any input offset voltage present in the amplifier.

The SX1125 incorporates a programmable level detect function to identify when the input signal has been lost. This information can be fed back to the Disable input of the device to maintain stability under loss of signal conditions. Using the V_{set} pin the sensitivity of the level detect can be adjusted. The C_{LD} input is used to filter the level detect input so that random noise spikes are filtered out.

The MC10SX1125 is compatible with MECL10H logic levels.

- Wideband Operation: 20kHz to 550MHz
- Programmable Input Signal Level Detection
- Operation with single +5V or standard ECL supply
- Standard 16-lead SOIC Package
- Fully Differential Design to Minimize Noise Affects
- 10KH Compatible

BLOCK DIAGRAM

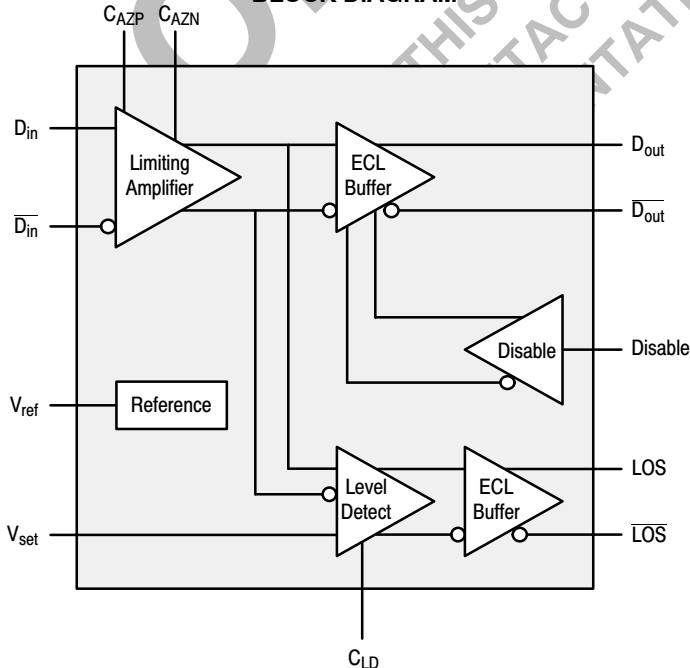

ON Semiconductor

<http://onsemi.com>

MARKING DIAGRAM

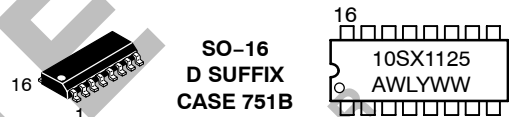

SO-16
D SUFFIX
CASE 751B

A = Assembly Location
WL = Wafer Lot
Y = Year
WW = Work Week

PIN ASSIGNMENT

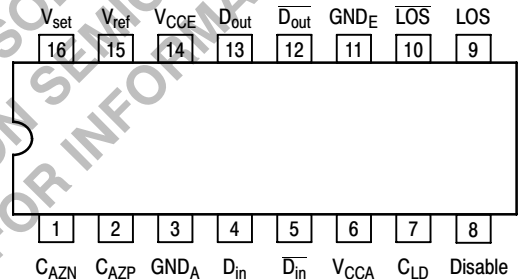

Pinout: 16-Lead Plastic Package
(Top View)

ORDERING INFORMATION

Device	Package	Shipping
MC10SX1125D	SO-16	48 / Rail
MC10SX1125DR2	SO-16	2500 / Reel

MC10SX1125

FUNCTION TABLE

Pin	Function
C _{AZN}	Auto-zero capacitor pin. A capacitor between this pin and C _{AZP} cancels any offset inherent to the limiting amplifier.
C _{AZP}	Auto-zero capacitor pin. A capacitor between this pin and C _{AZN} cancels any offset inherent to the limiting amplifier.
GND _A	Analog ground pin. Ground for PECL operation or -5.2V for standard ECL operation. GND _A and GND _E must be at the same potential.
D _{in} , \overline{D}_{in}	Differential data input.
V _{CCA}	Analog power supply pin. +5V for PECL operation or ground for standard ECL operation. V _{CCA} and V _{CCE} must be at the same potential.
C _{LD}	Filter capacitor for the level detect comparator. Capacitor should be connected to V _{CCA} .
Disable	When asserted LOW, or left open and pulled LOW via the input pulldown resistor, the output buffer will be enabled and will respond to the input stimulus on the D _{in} input. Forcing Disable HIGH will force the D _{out} output LOW and its complimentary output HIGH.
LOS	Loss of signal. This output will go HIGH when the input signal falls below (V _{set} /100) mV _{P-P} .
GND _E	Digital ground pin. Ground for PECL operation or -5.2V for standard ECL operation. GND _A and GND _E must be at the same potential.
D _{out} , \overline{D}_{out}	Differential data outputs.
V _{CCE}	Digital power supply pin. +5V for PECL operation or ground for standard ECL operation. V _{CCA} and V _{CCE} must be at the same potential.
V _{ref}	Reference voltage for threshold level set voltage division network (2.64V).
V _{set}	Input threshold level detect setting input. Input generated from voltage divider between V _{ref} and GND _A .

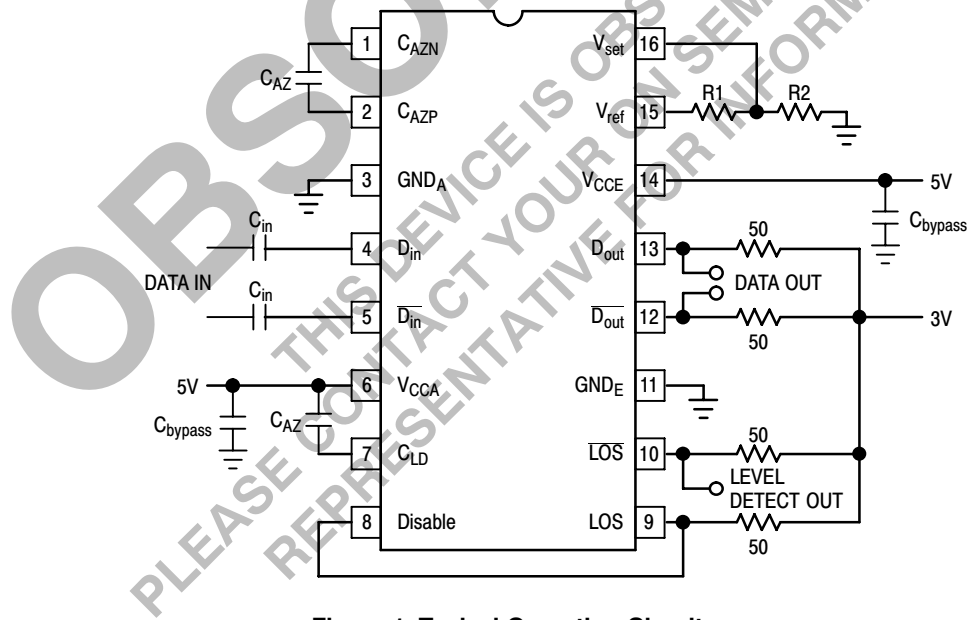

Figure 1. Typical Operating Circuit

Coupling Capacitors

The SX1125 inputs must be AC coupled to allow proper operation of the offset correction function. The coupling capacitors, C_{in} , must be large enough to pass the lowest input frequency of interest.

$$C_{in} = \frac{1}{2\pi (R_{in}) (f_{low})}$$

where R_{in} = input resistance = 5000Ω
 f_{low} = lowest frequency.

Auto-zero Capacitors

A feedback amplifier is used to cancel the offset voltage of the forward signal path, so the input to the internal ECL comparator is at its toggle point in the absence of any input signal. The time constant of the cancelling circuitry is set by an external capacitor (C_{AZ}) connected between Pins 1 and 2. The formula for the calculation of the auto-zero capacitor is:

$$C_{AZ} = \frac{150}{2\pi (R_{AZ}) (f_{low})}$$

where R_{AZ} = internal driving impedance = 290kΩ
 f_{low} = lowest frequency.

Input Signal Level Detector

The SX1125 allows for user programmable input signal level-detection and can automatically disable the switching of its ECL data output if the input level is below a set threshold. This prevents the outputs from reacting to noise in the absence of a valid input signal, and ensures that data will only be transmitted when the signal-to-noise ratio is sufficient for low bit-error-rate system operation. Complimentary ECL flags (LOS and LOSB) indicate whether the input signal is above or below the desired threshold level. In the level detect system, the input signal is amplified and rectified before being compared to a programmable reference. A filter is included to prevent noise spikes from triggering the level-detector. The filter has a nominal 1μs time constant, and additional filtering can be achieved by using an external capacitor (C_{LD}) from Pin 7 to V_{CCA} (the internal driving impedance is nominally 28k). The formula for the calculation of the C_{LD} capacitor is:

$$C_{LD} = \frac{t}{R_Z}$$

where R_Z = internal driving impedance = 28kΩ
 t = LOS filter time constant.

DC CHARACTERISTICS ($GND_A = GND_E = \text{Ground}$; $V_{CCA} = V_{CCE} = 4.5V \text{ to } 5.5V$)

Symbol	Characteristic	Min	Typ	Max	Unit	Condition
V_{IN}	Input Signal Voltage (D_{in}) Single-Ended	0.008		1.5	V_{P-P}	Note 1.
V_{OS}	Input Offset Voltage			50	μV	
V_N	Input RMS Noise			225	μV	
V_{TH}	Input Level Detect Programmability	8.0		20	mV $_{P-P}$	
V_{HYS}	Level Detect Hysteresis	1.5	2.5	7.0	dB	Note 2.
I_{IH}	Input HIGH Current Disable			150	μA	
I_{CC}	Power Supply Current		33	45	mA	

1. This device functions with $V_{in,min} = 6mV_{P-P}$ but with increased BER (See BER data).
2. This device has an anomaly in V_{HYS} when $0.65 < V_{SET} < 0.75V$. Operation in this region is not recommended.

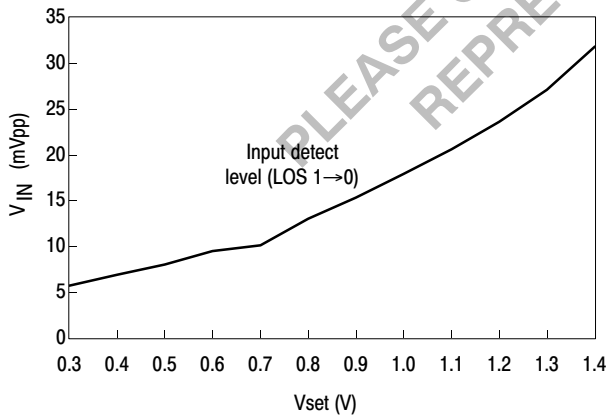

Figure 2. LOS versus Vset ($T_A = 25^\circ C$)

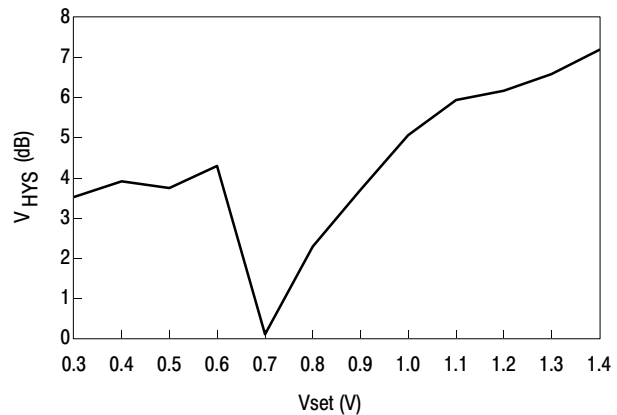

Figure 3. LOS Hysteresis ($T_A = 25^\circ C$)

MC10SX1125

I/O DC CHARACTERISTICS¹

Symbol	Characteristic	-40°C		0°C		25°C		85°C		Unit
		Min	Max	Min	Max	Min	Max	Min	Max	
V _{OH}	Output HIGH Voltage V _{CC} = -4.5 to -5.5V V _{CC} = 5.0V ²	1080 3920	-890 4110	1020 3980	-840 4160	-980 4020	-810 4190	-910 4090	-720 4280	mV
V _{OL}	Output LOW Voltage V _{CC} = -4.5 to -5.5V V _{CC} = 5.0V ²	-1950 3050	-1650 3350	-1950 3050	-1630 3370	-1950 3050	-1630 3370	-1950 3050	-1595 3405	mV
V _{IH}	Input HIGH Voltage ³ V _{CC} = -4.5 to -5.5V V _{CC} = 5.0V ²	-1230 3770	-890 4110	-1170 3830	-840 4160	-1130 3870	-810 4190	-1060 3940	-720 4280	mV
V _{IL}	Input LOW Voltage ³ V _{CC} = -4.5 to -5.5V V _{CC} = 5.0V ²	-1950 3050	-1500 3500	-1950 3050	-1480 3520	-1950 3050	-1480 3520	-1950 3050	-1445 3555	mV
I _{IL}	Input LOW Current ³	0.5		0.5		0.5		0.3		μA

- 10SX circuits are designed to meet the DC specifications shown in the table after thermal equilibrium has been established. The circuit is in a test socket or mounted on a printed circuit board and transverse airflow greater than 500lfpm is maintained. Outputs are terminated through a 50Ω resistor to -2.0 volts except where otherwise specified on the individual data sheets.
- Limits hold for V_{CC} = 5.0V only. Parametric values will vary 1:1 with any variation of V_{CC}.
- Parametric values for the Disable input only.

AC CHARACTERISTICS (V_{CCA} = V_{CCE} = 4.5V to 5.5V)

Symbol	Characteristic	Min	Typ	Max	Unit	Condition
BW _{min}	Lower -3dB Bandwidth			20	kHz	
BW _{max}	Upper -3dB Bandwidth	550			MHz	
t _{PWD}	Pulse Width Distortion			70	ps	
t _r , t _f	Rise/Fall Times	150	250	650	ps	20% - 80%
R _{AZ}	Auto-Zero Output Resistance	200	325	450	kΩ	
R _F	Level Detect Filter Resistance	14	25	41	kΩ	
t _{LD}	Level Detect Time Constant	0.5		4.0	μs	

BER (Bit-Error-Rate)

Using a 622Mb/s SONET STS-12 pattern, the SX1125 shows the following typical BERs at T_A = 25°C:

Input V _{pp}	BER
6mV	4E-13
7mV	<1E-14
8mV	<5E-15

MC10SX1125

PACKAGE DIMENSIONS

SO-16
D SUFFIX
CASE 751B-05
ISSUE J

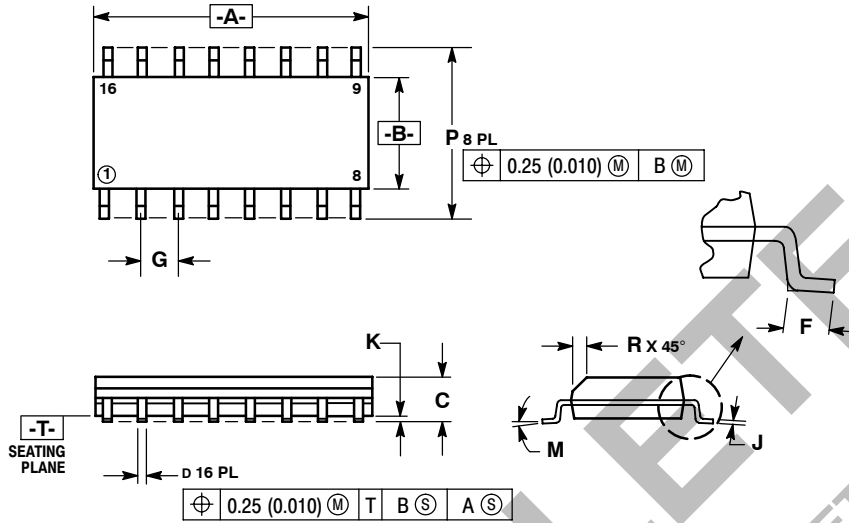

NOTES:

1. DIMENSIONING AND TOLERANCING PER ANSI Y14.5M, 1982.
2. CONTROLLING DIMENSION: MILLIMETER.
3. DIMENSION A AND B DO NOT INCLUDE MOLD PROTRUSION.
4. MAXIMUM MOLD PROTRUSION 0.15 (0.006) PER SIDE.
5. DIMENSION D DOES NOT INCLUDE DAMBAR PROTRUSION. ALLOWABLE DAMBAR PROTRUSION SHALL BE 0.127 (0.005) TOTAL IN EXCESS OF THE D DIMENSION AT MAXIMUM MATERIAL CONDITION.

DIM	MILLIMETERS		INCHES	
	MIN	MAX	MIN	MAX
A	9.80	10.00	0.386	0.393
B	3.80	4.00	0.150	0.157
C	1.35	1.75	0.054	0.068
D	0.35	0.49	0.014	0.019
F	0.40	1.25	0.016	0.049
G	1.27 BSC		0.050 BSC	
J	0.19	0.25	0.008	0.009
K	0.10	0.25	0.004	0.009
M	0°	7°	0°	7°
P	5.80	6.20	0.229	0.244
R	0.25	0.50	0.010	0.019

ON Semiconductor and are registered trademarks of Semiconductor Components Industries, LLC (SCILLC). SCILLC reserves the right to make changes without further notice to any products herein. SCILLC makes no warranty, representation or guarantee regarding the suitability of its products for any particular purpose, nor does SCILLC assume any liability arising out of the application or use of any product or circuit, and specifically disclaims any and all liability, including without limitation special, consequential or incidental damages. "Typical" parameters which may be provided in SCILLC data sheets and/or specifications can and do vary in different applications and actual performance may vary over time. All operating parameters, including "Typicals" must be validated for each customer application by customer's technical experts. SCILLC does not convey any license under its patent rights nor the rights of others. SCILLC products are not designed, intended, or authorized for use as components in systems intended for surgical implant into the body, or other applications intended to support or sustain life, or for any other application in which the failure of the SCILLC product could create a situation where personal injury or death may occur. Should Buyer purchase or use SCILLC products for any such unintended or unauthorized application, Buyer shall indemnify and hold SCILLC and its officers, employees, subsidiaries, affiliates, and distributors harmless against all claims, costs, damages, and expenses, and reasonable attorney fees arising out of, directly or indirectly, any claim of personal injury or death associated with such unintended or unauthorized use, even if such claim alleges that SCILLC was negligent regarding the design or manufacture of the part. SCILLC is an Equal Opportunity/Affirmative Action Employer. This literature is subject to all applicable copyright laws and is not for resale in any manner.

PUBLICATION ORDERING INFORMATION

LITERATURE FULFILLMENT:
Literature Distribution Center for ON Semiconductor
P.O. Box 5163, Denver, Colorado 80217 USA
Phone: 303-675-2175 or 800-344-3860 Toll Free USA/Canada
Fax: 303-675-2176 or 800-344-3867 Toll Free USA/Canada
Email: orderlit@onsemi.com

N. American Technical Support: 800-282-9855 Toll Free
USA/Canada
Europe, Middle East and Africa Technical Support:
Phone: 421 33 790 2910
Japan Customer Focus Center
Phone: 81-3-5773-3850

ON Semiconductor Website: www.onsemi.com
Order Literature: <http://www.onsemi.com/orderlit>

For additional information, please contact your local Sales Representative