

Helping Customers Innovate, Improve & Grow



### Features

- Commercial and MIL models
- Fully RoHS Compliant \*
- Temperature range from 0°C to 70°C to -55°C to +125°C
- Standard 4 and 14 pin DIP hermetic packages
- Available with Class B-Screening per MIL-PRF-55310
- Previous Model: CO-401, CO-402, CO-406, CO-441, CO-442, CO-446  
MC724, MC728, MC741, MC748
- Made in USA



\* ( Except parts with Sn-Pb Solder Coated Option )

### Performance Specifications

Parameter	Frequency Stabilities				Condition
	Min	Typ	Max	Units	
vs. operating temperature range (referenced to +25°C)	-15		+15	ppm	0... +70°C
	-25		+25	ppm	
	-50		+50	ppm	
	-100		+100	ppm	
	-25		+25	ppm	-40... +85°C
-50		+50	ppm		
-100		+100	ppm		
	-50		+50	ppm	-55... +85°C
	-100		+100	ppm	
	-50		+50	ppm	-55... +105°C
	-100		+100	ppm	
	-50		+50	ppm	-55... +125°C
	-100		+100	ppm	
Initial tolerance	-15		+15	ppm	@+25°C
	-25		+25	ppm	@+25°C
	-50		+50	ppm	@+25°C
	-100		+100	ppm	@+25°C

Performance Specifications					
Parameter	Frequency Stabilities				Condition
	Min	Typ	Max	Units	
Overall tolerance (Referenced to +25°C) (includes operating temperature and initial accuracy)	-20		+20	ppm	0... +70°C
	-25		+25	ppm	
	-50		+50	ppm	
	-100		+100	ppm	
	-25		+25	ppm	-40... +85°C
-50		+50	ppm		
-100		+100	ppm		
	-50		+50	ppm	-55... +85°C
	-65		+65	ppm	
	-100		+100	ppm	-55... +105°C
	-50		+50	ppm	
	-65		+65	ppm	-55... +125°C
	-100		+100	ppm	
vs. supply voltage change	-2		+2	ppm	VS ± 5% Load ± 5% after 30 days of operation
vs. load change	-1		+1	ppm	
vs. aging / 1st year	-3		+3	ppm	
vs. aging / year (following years)	-1		+1	ppm	
Supply Voltage (Vs)					
Supply voltage	4.75	5.0	5.25	VDC	
Supply voltage	3.135	3.3	3.465	VDC	
Supply voltage	2.375	2.5	2.625	VDC	
Supply voltage	1.71	1.8	1.89	VDC	
Current consumption (+5 VDC)			15 20 40	mA mA mA	ACMOS or TTL 1.0 to 23.9 MHz ACMOS or TTL 24 to 49.9 MHz ACMOS or TTL 50 to 125.00 MHz
Current consumption (+3.3 VDC or +2.5 VDC)			6 8 12 16 40	mA mA mA mA mA	ACMOS 1.0 to 14.9 MHz ACMOS 15.0 to 39.9 MHz ACMOS 40.0 to 59.9 MHz ACMOS 60.0 to 84.9 MHz ACMOS 85.0 to 125.0 MHz
Current consumption (+1.8 VDC)			1.5 2 3 4 10	mA mA mA mA mA	ACMOS 1.0 to 14.9 MHz ACMOS 15.0 to 39.9 MHz ACMOS 40.0 to 59.9 MHz ACMOS 60.0 to 84.9 MHz ACMOS 85.0 to 125.0 MHz
RF Output					
Signal	HCMOS / ACMOS				
Load		15		pF	
Signal Level (Vol)			0.5 0.3 0.25 0.2	VDC VDC VDC VDC	with Vs=5.0V and 15pF load with Vs=3.3V and 15pF load with Vs= 2.5V and 15pF load with Vs= 1.8V and 15pF load
Signal Level (Voh)	4.5 3.0 2.25 1.62			VDC VDC VDC VDC	with Vs=5.0V and 15pF load with Vs=3.3V and 15pF load with Vs=2.5V and 15pF load with Vs=1.8V and 15pF load
Rise and fall times for ACMOS (measured 10% to 90%)			10 6 3	ns ns ns	1.0 to 23.9 MHz 24.0 to 79.9 MHz 80.0 to 125.0 MHz
Duty cycle	45 40		55 60	% %	@ 50% < 15 MHz @ 50% => 15 MHz

## Performance Specifications

Parameter	Frequency Stabilities				Condition
	Min	Typ	Max	Units	
<b>Signal</b>	<b>TTL</b>				
Load			10	TTL	
Signal Level (Vol)			0.4	VDC	
Signal Level (Voh)	+2.4			VDC	
Rise and fall times for TTL (measured 0.8 V to 2.0 V)			5 3	ns ns	1.0 to 23.9 MHz 24.0 to 125 MHz
Duty cycle	45 40		55 60	% %	@ 1.4V < 15 MHz @ 1.4V >= 15 MHz
Absolute Maximum Ratings					
Supply voltage (Vs)			7.0	V	with Vs=5.0VDC and 3.3 VDC
Supply voltage (Vs)			3.6	V	with Vs=2.5VDC and 1.8 VDC
Operable temperature range	-55		+125	°C	
Storage temperature range	-62		+125	°C	

## Additional Parameters

Screening	Vectron Verification	
	Class B, MIL-PRF-55310, Rev. E	
Output Enable Hi	Logic "0" input = Outputs disabled (Tri-state) Logic "1" or floating input = Outputs enabled	
Processing & Packing	Handling & processing note	

## Standard Environmentals

Vibration	MIL-STD-202, Method 204, Condition G (30 G, 10Hz-2000Hz)
Shock	MIL-STD-202, Method 213, Condition I (100 G, 6ms, Sawtooth)
Acceleration	MIL-STD-883, Method 2001, Condition A (5000 G, Y1 Plane)
Temperature Cycling	MIL-STD-883, Method 1010, Condition B
Thermal Shock	MIL-STD-202, Method 107, Condition B
Solderability	MIL-STD-202, Method 208
Leak Test (Fine and Gross)	MIL-STD-883, Method 1014, Condition A1 and C1

# Outline Drawing / Enclosure

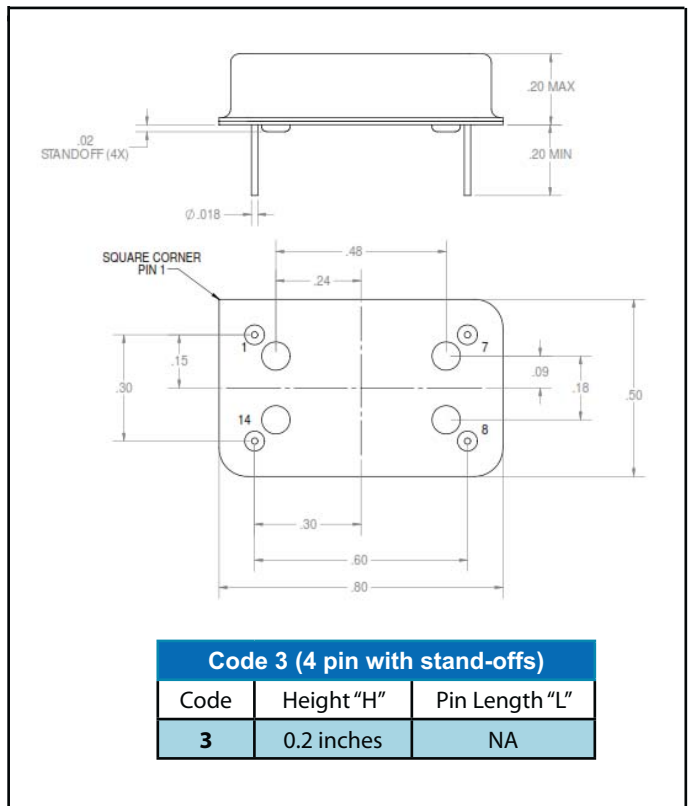
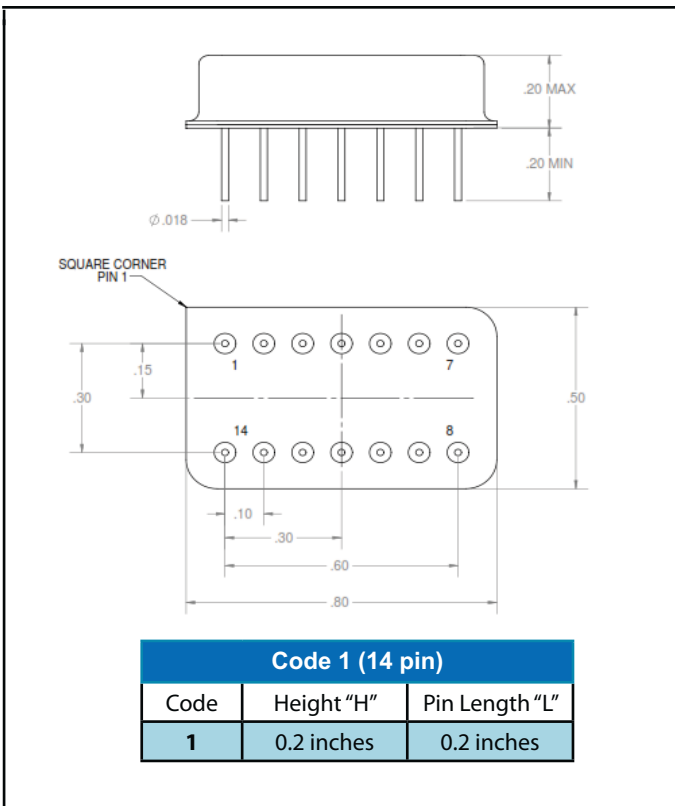
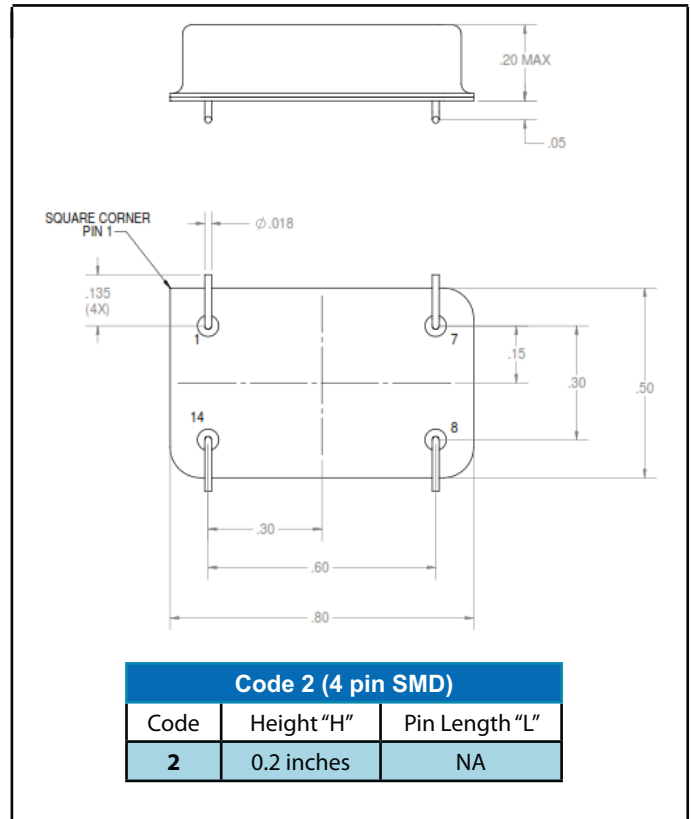
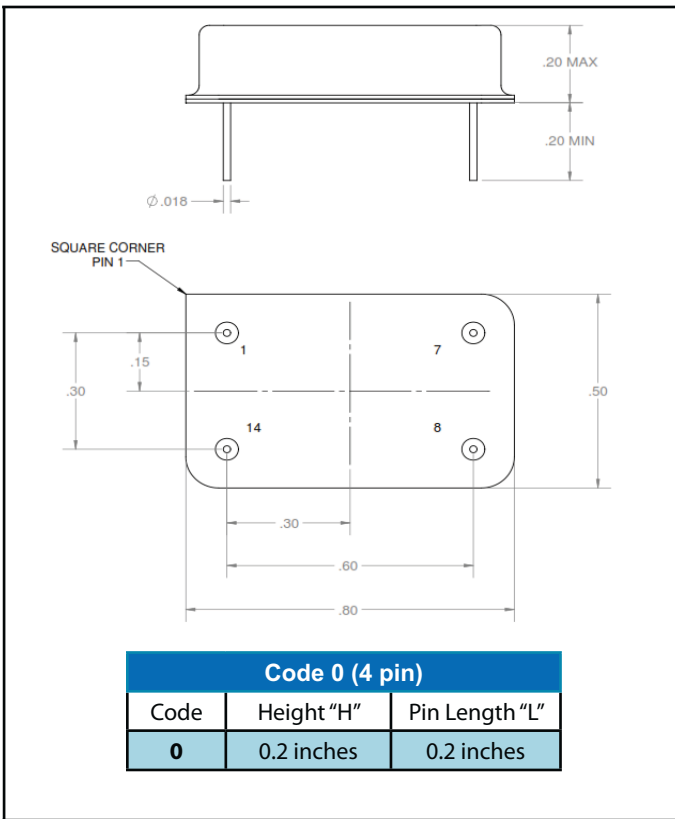

Pin Connections			
1	No Connection	14	Supply Voltage
7	Ground	8	RF Output

## Recommended Reflow Profile

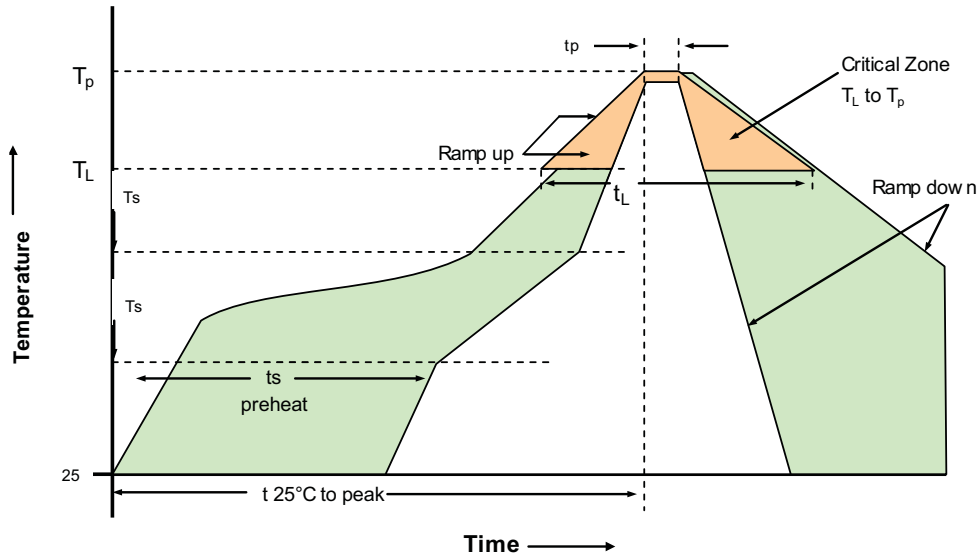

### 230°C Reflow Profile

Profile Feature	Sn-Pb Assembly	Profile Feature	Sn-Pb Assembly
Average ramp-up rate (TL to TP)	3°C/seconds max.	Time 25°C to Peak Temperature	4 minutes max.
Preheat - Temperature min T <sub>sm</sub> - Temperature Min T <sub>smax</sub> - Time (min to max) (ts)	135°C 155°C 60-90 seconds	Time maintained above - Temperature (TL) - Time (t <sub>L</sub> )	183°C 45-60 seconds
T <sub>smax</sub> to TL -Ramp-up Rate	3°C/seconds max.		
Time maintained above - Temperature (TL) - Time (TL)	183°C 40-60 seconds	Time within 5°C of actual Peak Temperature (tp)	10-20 seconds max.
Peak Temperature (Tp)	max 230°C	Ramp-down Rate	6°C/seconds max.

**Note:** All temperatures refer to topside of the package, measured on the package body surface.

### 260°C Reflow Profile

Profile Feature	Pb-Free Assembly	Profile Feature	Pb-Free Assembly
Average ramp-up rate (TL to TP)	3°C/seconds max.	Time 25°C to Peak Temperature	8 minutes max.
Preheat - Temperature min T <sub>sm</sub> - Temperature min T <sub>smax</sub> - Time (min to max) (ts)	150°C 200°C 60-180 seconds	Time maintained above - Temperature (TL) - Time (t <sub>L</sub> )	217°C 60-150 seconds
T <sub>smax</sub> to TL -Ramp-up Rate	3°C/seconds max.		
Time maintained above - Temperature (TL) - Time (TL)	217°C 60-150 seconds	Time within 5°C of actual Peak Temperature (tp)	20-40 seconds max.
Peak Temperature (Tp)	max 260°C	Ramp-down Rate	6°C/seconds max.

**Note:** All temperatures refer to topside of the package, measured on the package body surface.

# Standard Shipping Method

NOTES:

1. MATERIAL: CLEAR R-PVC
2. ANTISTATIC TREATED/PRINTED (BLUE INK) .125" HIGH LETTERS
3. MANUFACTURER: THIELEX
4. NO HOLES
5. DIMENSIONS ARE SHOWN FOR REFERENCE ONLY.

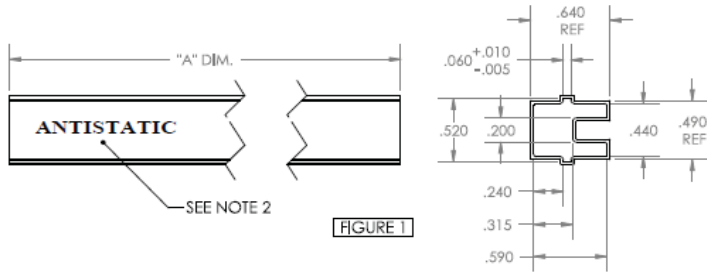

FIGURE 1

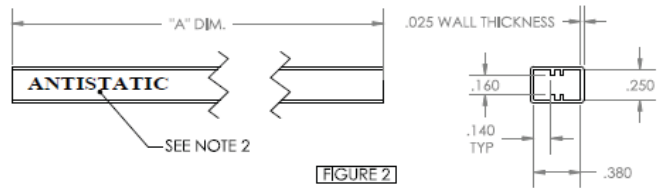
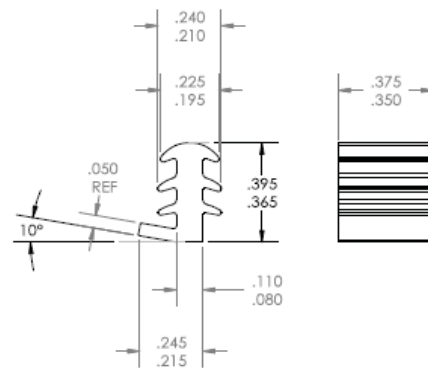

FIGURE 2

NOTES:

1. MATERIAL: KRATON (BLACK)
2. MANUFACTURER: PEAK INTERNATIONAL



# Ordering Information

## PX - 400 0 - D A T - F K A B - 10M000000

**Product Family**  
PX: PXO

**Package**  
13 x 20 mm

**Package Code**

- 0: 0.2" (4 pin)
- 1: 0.2" (14 pin)
- 2: 0.2" (4 pin SMD)
- 3: 0.2" (4 pin with Stand-offs)
- 4: 0.2" (4 pin with solder coated leads)
- 5: 0.2" (14 pin with solder coated leads)
- 6: 0.2" (4 pin SMD with solder coated leads)
- 7: 0.2" (4 pin with Stand-offs and solder coated leads)

**Supply Voltage**

- D:** 5 Vdc ±5%
- E:** 3.3 Vdc ±5%
- H:** 2.5 Vdc ±5%

**RF Output Code**

- A:** AC MOS, HCMOS
- B:** TTL

**Temperature Range**

- A:** -55°C to +85°C
- B:** -55°C to +105°C
- C:** -55°C to +125°C
- E:** -40°C to +85°C
- T:** 0°C to +70°C

**Frequency**

**Screening Option**

- B:** MIL-PRF-55310 "B" level
- X:** No Screening

**Enable Code**

- A:** Enable Hi, Tristate
- X:** No Enable

**Temperature Stability Code**

(Reference to **Table: I**)

- D:** ±15ppm
- F:** ±25ppm
- K:** ±50ppm
- P:** ±80ppm
- S:** ±100ppm
- Z:** ±65PPM
- X:** Use with Overall Tolerance Code

**Accuracy Code @ 25°C** or **Overall Temp Stability Code**

(Reference to **Table: II**)

- D:** ±15ppm
- F:** ±25ppm
- K:** ±50ppm
- P:** ±80ppm
- S:** ±100PPM
- Z:** ±65PPM

Available Temperature Stability Code	
Temp Range	Temp Stability
<b>A:</b> -55°C to +85°C	<b>K:</b> ± 50ppm
	<b>Z:</b> ± 65ppm
<b>B:</b> -55°C to +105°C	<b>P:</b> ± 80ppm
	<b>S:</b> ± 100ppm
<b>E:</b> -40°C to +85°C	<b>F:</b> ± 25ppm
	<b>K:</b> ± 50ppm
	<b>Z:</b> ± 65ppm
	<b>P:</b> ± 80ppm
	<b>S:</b> ± 100ppm
<b>T:</b> 0°C to +70°C	<b>D:</b> ± 15ppm
	<b>F:</b> ± 25ppm
	<b>K:</b> ± 50ppm
	<b>Z:</b> ± 65ppm
	<b>S:</b> ± 100ppm

**Table: I**

Available Overall Tolerance Code		
Temp Range	Overall Tolerance	Temp Stability
<b>A:</b> -55°C to +85°C	<b>Z:</b> ± 65ppm	<b>X</b>
	<b>P:</b> ± 80ppm	<b>X</b>
<b>B:</b> -55°C to +105°C	<b>S:</b> ± 100ppm	<b>X</b>
	<b>K:</b> ± 50ppm	<b>X</b>
<b>C:</b> -55°C to +125°C	<b>Z:</b> ± 65ppm	<b>X</b>
	<b>P:</b> ± 80ppm	<b>X</b>
	<b>S:</b> ± 100ppm	<b>X</b>
<b>E:</b> -40°C to +85°C	<b>F:</b> ± 25ppm	<b>X</b>
	<b>K:</b> ± 50ppm	<b>X</b>
	<b>Z:</b> ± 65ppm	<b>X</b>
	<b>P:</b> ± 80ppm	<b>X</b>
	<b>S:</b> ± 100ppm	<b>X</b>
<b>T:</b> 0°C to +70°C	<b>F:</b> ± 25ppm	<b>X</b>
	<b>K:</b> ± 50ppm	<b>X</b>
	<b>Z:</b> ± 65ppm	<b>X</b>
	<b>P:</b> ± 80ppm	<b>X</b>
	<b>S:</b> ± 100ppm	<b>X</b>

**Table: II**

This page is purposely left blank

**Notes:**

- 1. Contact factory for improved stabilities or additional product options. Not all options and codes are available at all frequencies.
- 2. Unless otherwise stated all values are valid after warm-up time and refer to typical conditions for supply voltage, frequency control voltage, load, temperature (25°C).
- 3. Subject to technical modification.

**For Additional Information, Please Contact**

**USA:**

Vectron International  
267 Lowell Road, Unit 102  
Hudson, NH 03051  
Tel: 1.888.328.7661  
Fax: 1.888.329.8328

**Europe:**

Vectron International  
Landstrasse, D-74924  
Neckarbischofsheim, Germany  
Tel: +49 (0) 3328.4784.17  
Fax: +49 (0) 3328.4784.30

**Asia:**

Vectron International  
68 Yin Cheng Road(C), 22nd Floor  
One LuJiaZui  
Pudong, Shanghai 200120, China  
Tel: 86.21.6194.6886  
Fax: 86.21.6194.6699

**Disclaimer**

Vectron International reserves the right to make changes to the product(s) and or information contained herein without notice. No liability is assumed as a result of their use or application. No rights under any patent accompany the sale of any such product(s) or information.