



Description

The MK1479 is a low cost way of generating all necessary clocks for boards using Digital Semiconductor's 21230 video codec.

The chip provides zero ppm accuracy on all of the clocks, eliminating the need for buying multiple tight-tolerance crystals and oscillators. A single 27.00 MHz crystal is the only accurate frequency source required. The MK1479 then synthesizes all clocks exactly from that crystal.

MicroClock manufactures the largest variety of multimedia clock synthesizers for all applications. Consult MicroClock to eliminate crystals and oscillators from your board.

Features

- Packaged in 20 pin SOIC
- Uses a single 27.000 MHz crystal
- 5V±10% operating voltage, with ability to run 71.5MHz clocks at 3.3V using VDDP
- Zero ppm synthesis error in all clocks
- 25mA output drive capability at TTL levels
- Advanced, low power, sub-micron CMOS process

Block Diagram

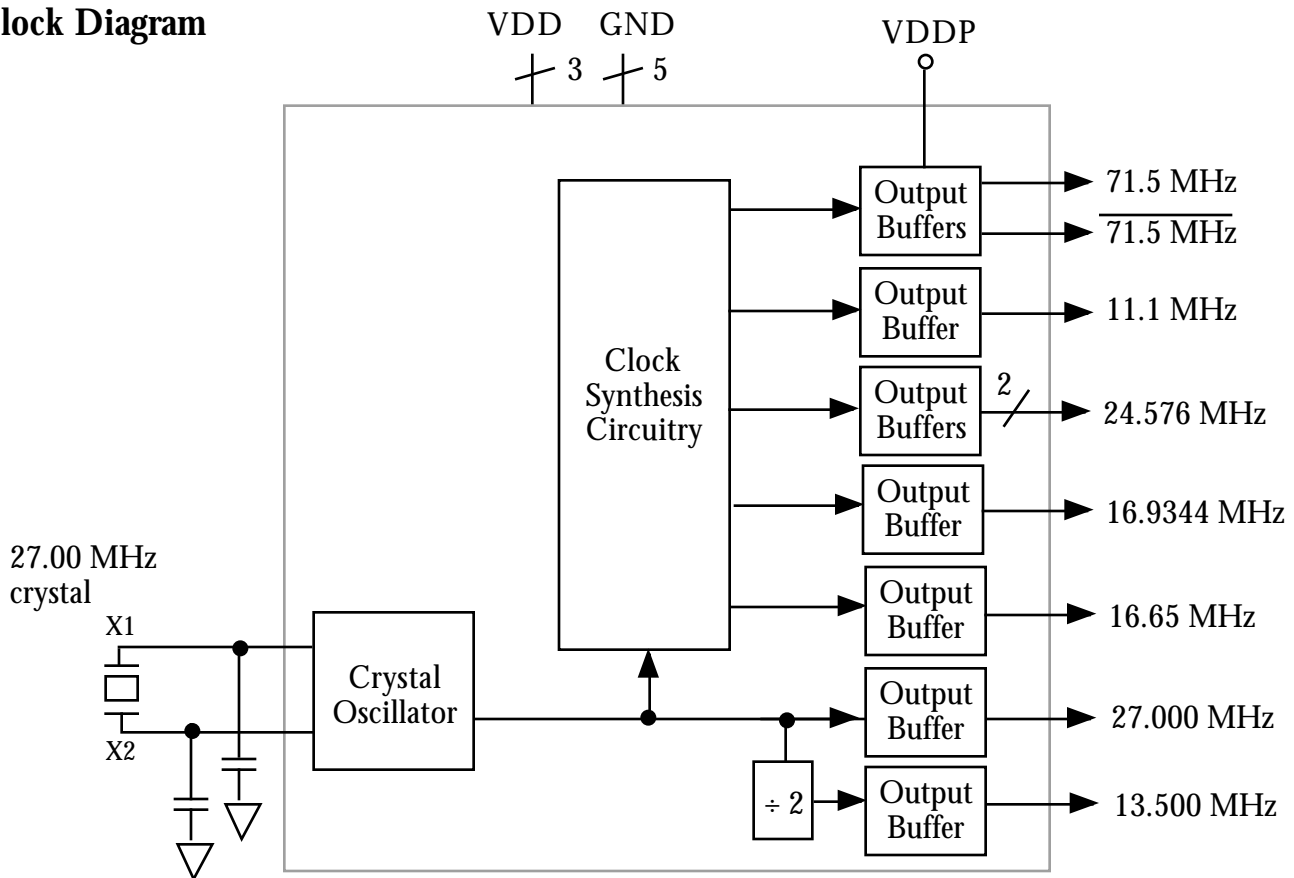



Pin Assignment

GND	□ 1	20	□ VDDP
X2	□ 2	19	□ 71.5M
X1	□ 3	18	□ 71.5M
VDD	□ 4	17	□ GND
GND	□ 5	16	□ 27M
VDD	□ 6	15	□ VDD
GND	□ 7	14	□ GND
16.65M	□ 8	13	□ 24.576M
11.1M	□ 9	12	□ 24.576M
13.5M	□ 10	11	□ 16.9344M

Pin Descriptions

Number	Name	Type	Description
1	GND	P	Connect to ground.
2	X2	O	Crystal connection. Connect to a 27.00 MHz fundamental crystal.
3	X1	I	Crystal connection. Connect to a 27.00 MHz fundamental crystal.
4	VDD	P	Connect to +5V.
5	GND	P	Connect to ground.
6	VDD	P	Connect to +5V.
7	GND	P	Connect to ground.
8	16.65M	O	16.65 MHz clock output for AD2181.
9	11.1M	O	11.10 MHz clock output.
10	13.5M	O	13.50 MHz clock output.
11	16.9344M	O	16.9344 MHz clock output for AD1848.
12	24.576M	O	24.576 MHz clock output for AD1848.
13	24.576M	O	24.576 MHz clock output for Philips 7111.
14	GND	P	Connect to ground.
15	VDD	P	Connect to +5V.
16	27M	O	27.00 MHz reference clock output.
17	GND	P	Connect to ground.
18	71.5M	O	71.5 MHz inverted clock output (copy of 71.5 delayed 7ns). Amplitude = VDDP.
19	71.5M	O	71.5 MHz clock output for DEC processor. Amplitude = VDDP.
20	VDDP	P	Connect to +5V or +3.3V. Determines amplitude of 71.5MHz clocks.

Key: I = Input, O = output, P = power supply connection

**Electrical Specifications**

Parameter	Conditions	Minimum	Typical	Maximum	Units
ABSOLUTE MAXIMUM RATINGS (note 1)					
Supply voltage, VDD	Referenced to GND			7	V
Inputs and Clock Outputs	Referenced to GND	-0.5		VDD+0.5	V
Ambient Operating Temperature		0		70	°C
Soldering Temperature	Max of 10 seconds			260	°C
Storage temperature		-65		150	°C
DC CHARACTERISTICS (VDD = 5.0V unless noted)					
Operating Voltage, VDD		4.5		5.5	V
Operating Voltage, VDDP		3.0	3.3	5.5	V
Input High Voltage, VIH, X1 pin only		3.5	2.5		V
Input Low Voltage, VIL, X1 pin only			2.5	1.5	V
Input High Voltage, VIH		2			V
Input Low Voltage, VIL				0.8	V
Output High Voltage, VOH	IOH=-25mA	2.4			V
Output Low Voltage, VOL	IOL=25mA			0.4	V
Output High Voltage, VOH, CMOS level	IOH=-8mA	VDD-0.4			V
Operating Supply Current, IDD	No Load		65		mA
Short Circuit Current	Each output		±100		mA
Frequency synthesis error	All clocks			0	ppm
AC CHARACTERISTICS (VDD = 5.0V unless noted)					
Input Frequency			27.00000		MHz
Output Clock Rise Time	0.8 to 2.0V			1.5	ns
Output Clock Fall Time	2.0 to 0.8V			1.5	ns
Output Clock Duty Cycle	At 1.4V	40		60	%
Maximum Absolute Jitter, short term			300		ps

Notes: 1. Stresses beyond those listed under Absolute Maximum Ratings could cause permanent damage to the device. Prolonged exposure to levels above the operating limits but below the Absolute Maximums may affect device reliability.

External Components

The MK1479 requires a minimum number of external components for proper operation. Decoupling capacitors of 0.1µF should be connected between VDD and GND, as close to the MK1479 as possible. A series termination resistor of 33 Ω may be used for each clock output. The 27.000 MHz crystal must be connected as close to the chip as possible. The 27.000 MHz crystal should be a parallel mode, fundamental cut. External capacitors from each of the X1 and X2 pins to ground should be added with a value in pF equal to $(C_L - 10.5) \cdot 2$, where C_L is the crystal load capacitance in pF. So for a crystal with load capacitance of 18pF, 15pF capacitors should be used.



Package Outline and Package Dimensions

20 pin SOIC

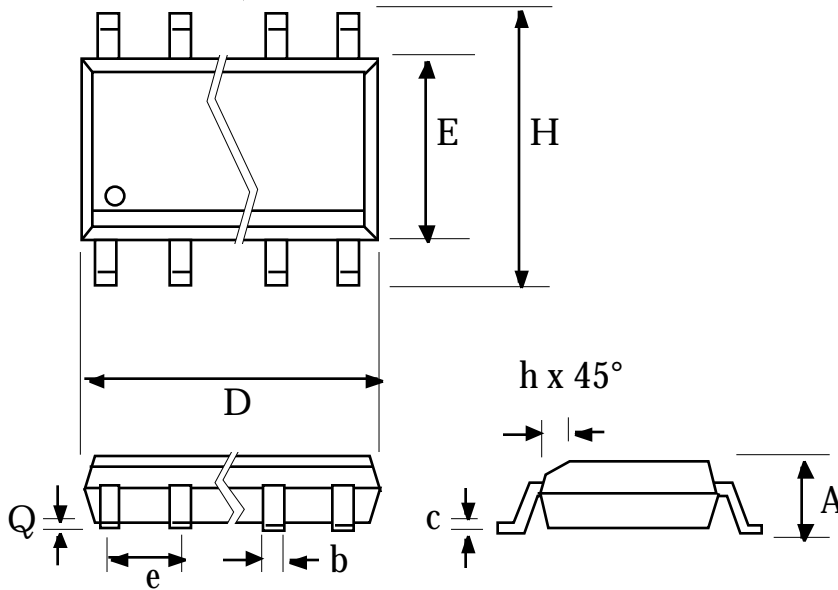

Symbol	Inches		Millimeters	
	Min	Max	Min	Max
A	0.092	0.104	2.3368	2.6416
b	0.014	0.019	0.356	0.483
c	0.009	0.012	0.229	0.305
D	0.490	0.512	12.446	13.005
E	0.290	0.300	7.366	7.620
H	0.394	0.419	10.008	10.643
e	.050 BSC		1.27 BSC	
h		0.016		0.406
Q	0.003	0.011	0.076	0.279

Ordering Information

Part/Order Number	Marking	Shipping packaging	Package	Temperature
MK1479S	MK1479S	tubes	20 pin SOIC	0-70°C
MK1479STR	MK1479S	tape and reel	20 pin SOIC	0-70°C

While the information presented herein has been checked for both accuracy and reliability, MicroClock Incorporated assumes no responsibility for either its use or for the infringement of any patents or other rights of third parties, which would result from its use. No other circuits, patents, or licenses are implied. This product is intended for use in normal commercial applications. Any other applications such as those requiring extended temperature range, high reliability, or other extraordinary environmental requirements are not recommended without additional processing by MicroClock. MicroClock reserves the right to change any circuitry or specifications without notice. MicroClock does not authorize or warrant any MicroClock product for use in life support devices or critical medical instruments.