

Cascadable Silicon Bipolar MMIC Amplifier

Technical Data

MSA-1023

Features

- **High Output Power:**
+27 dBm Typical P_{1dB} at 1.0 GHz
- **Low Distortion:**
37 dBm Typical IP_3 at 1.0 GHz
- **8.5 dB Typical Gain at 1.0 GHz**
- **Hermetic, Metal/Beryllia Stripline Package**
- **Impedance Matched to 25 Ω for Push-Pull Configurations**

Description

The MSA-1023 is a high performance, medium power silicon bipolar Monolithic Microwave Integrated Circuit (MMIC) housed in a hermetic, BeO flange package for good thermal characteristics.

This MMIC is designed for use in a push-pull configuration in a 25 Ω system. The MSA-1023 can also be used as a single-ended amplifier in a 50 Ω system with slightly reduced performance. Typical applications include narrow and broadband RF amplifiers in industrial and military systems.

The MSA-series is fabricated using HP's 10 GHz f_T , 25 GHz f_{MAX} , silicon bipolar MMIC process which uses nitride self-alignment, ion implantation, and gold metallization to achieve excellent performance, uniformity and reliability. The use of an external bias resistor for temperature and current stability also allows bias flexibility.

230 mil BeO Flange Package

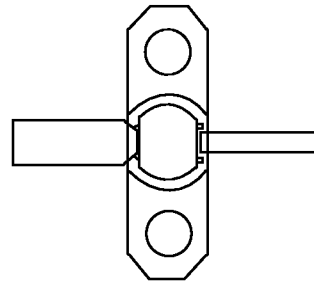

Typical Push-Pull Biasing Configuration

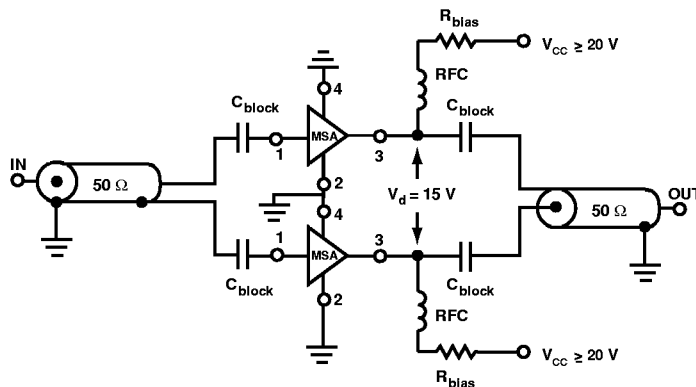

MSA-1023 Absolute Maximum Ratings

Parameter	Absolute Maximum ^[1]
Device Current	425 mA
Power Dissipation ^[2,3]	7.0 W
RF Input Power	+25 dBm
Junction Temperature	200°C
Storage Temperature	-65 to 200°C

Thermal Resistance^[2,4]:

$$\theta_{jc} = 15^{\circ}\text{C/W}$$

Notes:

1. Permanent damage may occur if any of these limits are exceeded.
2. $T_{\text{CASE}} = 25^{\circ}\text{C}$.
3. Derate at $66.7 \text{ mW}/^{\circ}\text{C}$ for $T_{\text{C}} > 95^{\circ}\text{C}$.
4. The small spot size of this technique results in a higher, though more accurate determination of θ_{jc} than do alternate methods. See MEASUREMENTS section "Thermal Resistance" for more information.

Electrical Specifications^[1], $T_{\text{A}} = 25^{\circ}\text{C}$

Symbol	Parameters and Test Conditions: $I_{\text{d}} = 325 \text{ mA}$, $Z_{\text{O}} = 25 \Omega$	Units	Min.	Typ.	Max.
G_{P}	Power Gain ($ S_{21} ^2$) $f = 1.0 \text{ GHz}$	dB	7.5	8.5	9.5
ΔG_{P}	Gain Flatness $f = 0.1 \text{ to } 2.0 \text{ GHz}$	dB		± 0.6	
$f_{3 \text{ dB}}$	3 dB Bandwidth ^[2]	GHz		2.5	
VSWR	Input VSWR $f = 0.1 \text{ to } 2.0 \text{ GHz}$			2.0:1	
	Output VSWR $f = 0.1 \text{ to } 2.0 \text{ GHz}$			2.8:1	
NF	25 Ω Noise Figure $f = 1.0 \text{ GHz}$	dB		7.0	
$P_{1 \text{ dB}}$	Output Power at 1 dB Gain Compression $f = 1.0 \text{ GHz}$	dBm	25.0	27.0	
IP_3	Third Order Intercept Point $f = 1.0 \text{ GHz}$	dBm		37.0	
t_{D}	Group Delay $f = 1.0 \text{ GHz}$	psec		250	
V_{d}	Device Voltage	V	13.5	15.0	16.5
dV/dT	Device Voltage Temperature Coefficient	mV/ $^{\circ}\text{C}$		-18.0	

Notes:

1. The recommended operating current range for this device is 150 to 400 mA. Typical performance as a function of current is on the following page.
2. Referenced from 10 MHz gain (G_{P}).

MSA-1023 Typical Scattering Parameters ($Z_0 = 50 \Omega$, $T_A = 25^\circ\text{C}$, $I_d = 325 \text{ mA}$)

Freq. GHz	S_{11}		S_{21}			S_{12}			S_{22}		k
	Mag	Ang	dB	Mag	Ang	dB	Mag	Ang	Mag	Ang	
0.001	.40	-121	15.3	5.85	149	-17.9	.128	22	.42	-99	0.69
0.005	.51	-167	8.5	2.67	156	-15.9	.160	6	.45	-161	1.05
0.010	.52	-174	7.5	2.36	166	-15.8	.162	3	.45	-171	1.16
0.025	.52	-178	7.2	2.28	172	-15.8	.162	1	.45	-177	1.20
0.050	.52	179	7.1	2.26	173	-15.8	.161	-1	.45	-179	1.21
0.100	.53	176	7.0	2.25	170	-15.8	.161	-3	.45	179	1.21
0.200	.53	172	7.0	2.25	163	-15.8	.161	-5	.46	174	1.21
0.400	.51	164	7.0	2.24	146	-15.8	.161	-11	.46	170	1.22
0.600	.48	157	7.0	2.24	130	-16.0	.159	-16	.45	165	1.23
0.800	.45	151	7.0	2.23	113	-16.1	.157	-21	.44	161	1.24
1.000	.42	146	7.0	2.23	95	-16.2	.155	-26	.44	157	1.24
1.200	.38	144	6.9	2.22	78	-16.4	.151	-31	.44	155	1.24
1.400	.35	145	6.8	2.20	61	-16.7	.146	-36	.45	154	1.24
1.600	.34	149	6.6	2.15	44	-17.0	.141	-41	.46	153	1.22
1.800	.36	152	6.3	2.07	19	-17.3	.136	-45	.49	150	1.18
2.000	.39	153	5.9	1.97	11	-17.7	.130	-49	.62	148	1.13
2.500	.51	148	4.6	1.69	-24	-18.3	.121	-52	.52	140	.91
3.000	.60	133	3.0	1.41	-57	-17.9	.127	-57	.70	128	.59

A model for this device is available in the DEVICE MODELS section.

Typical Performance, $T_A = 25^\circ\text{C}$

(unless otherwise noted)

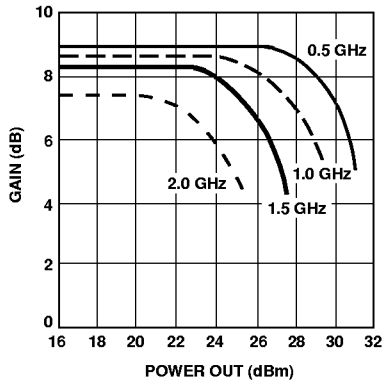

Figure 1. Typical Gain vs. Power Out, $Z_0 = 25 \Omega$, $I_d = 325 \text{ mA}$.

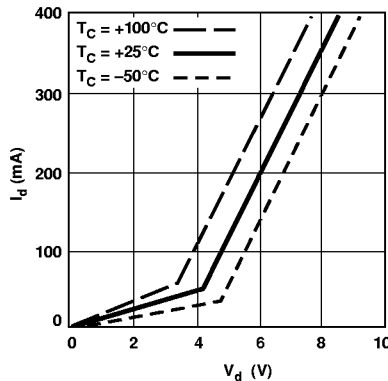

Figure 2. Device Current vs. Voltage.

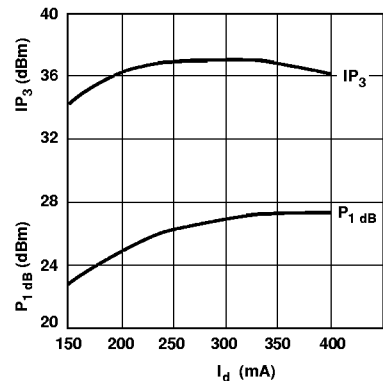

Figure 3. Output Power at 1 dB Gain Compression, Third Order Intercept Point vs. Current, $Z_0 = 25 \Omega$, $f = 1.0 \text{ GHz}$.

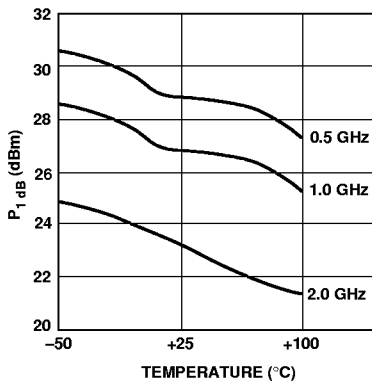

Figure 4. Output Power at 1 dB Gain Compression vs. Temperature, $Z_0 = 25 \Omega$, $I_d = 325 \text{ mA}$.

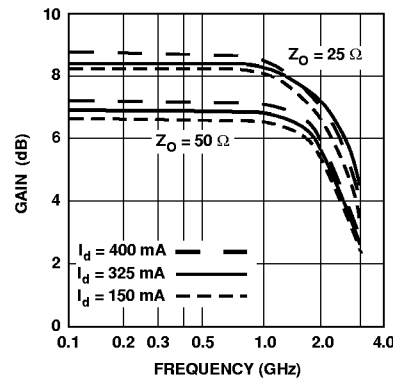

Figure 5. Gain vs. Frequency, $I_d = 325 \text{ mA}$.

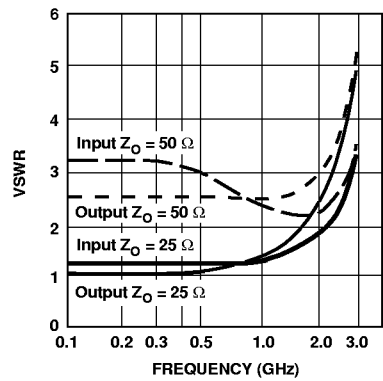

Figure 6. VSWR vs. Frequency, $I_d = 325 \text{ mA}$.

230 mil BeO Flange Package

