

**CMS68F256, CMS68F512
CMS68F1MB, CMS68F2MB
FLASH MEMORY CARDS**

SMNS301A—NOVEMBER 1992

- Industry Standard PCMCIA Cards
- Standard Card Size
(85,6 mm × 54,0 mm × 3,3 mm)
- Single 5-V Power Supply (± 5% Tolerance)
- Utilize TSOP-I (Thin Small Outline Package-Type I) Flash Memory Devices
- 68-Pin PCMCIA (Rev. 2.0) / JEIDA (Rev. 4.0) Compatible
- 8-Bit or 16-Bit User Configurable Organization
- Low Power Dissipation
- Operating Free-Air Temperature Range 0°C to 55°C
- Standard 68-Pin Two-Piece Connector
- All Input/Output Signals Fully TTL Compatible
- 3-State Output

**68-PIN MEMORY CARD†
(CONNECTOR VIEW)**

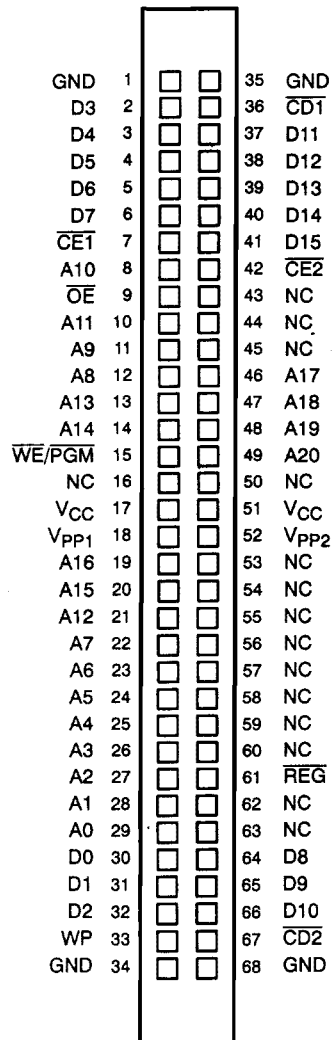

description

The CMS68Fxxx series are TI standard memory cards designed to be used either as an internal memory system or as external add-on memory according to PCMCIA/JEIDA industry standard card specifications. These cards are offered with a memory size from 256K bytes to 2048K bytes of Flash memory devices and the card organization (× 8 or × 16) is directly user configurable.

The cards are comprised of 2, 4, or 8 1M-byte or 2M-byte Flash memory devices in 32-lead plastic Thin Small Outline Packages (TSOP-I).

† Pinout shown is for maximum density card. See pin assignment table for specifics.

NC – No internal connection

available organizations

PART NUMBER	ORGANIZATION	ACCESS TIME	TOTAL DENSITY	CONNECTOR
CMS68F256-250	256K × 8 / 128K × 16	250 ns	256K-Bytes	Two-piece, 68 pin
CMS68F512-250	512K × 8 / 256K × 16	250 ns	512K-Bytes	Two-piece, 68 pin
CMS68F1MB-250	1M × 8 / 512K × 16	250 ns	1M-Bytes	Two-piece, 68 pin
CMS68F2MB-250	2M × 8 / 1M-Byte × 16	250 ns	2M-Bytes	Two-piece, 68 pin

PRODUCTION DATA Information is current as of publication date. Products conform to specifications per the terms of Texas Instruments standard warranty. Production processing does not necessarily include testing of all parameters.



POST OFFICE BOX 1443 • HOUSTON, TEXAS 77001

Copyright © 1992, Texas Instruments Incorporated

CMS68F256, CMS68F512
CMS68F1MB, CMS68F2MB
FLASH MEMORY CARDS
 SMNS301A—NOVEMBER 1992

pin assignments

'68F256	'68F512	'68F1MB	'68F2MB	PIN #	PIN #	'68F2MB	'68F1MB	'68F512	'68F256
GND	GND	GND	GND	1	35	GND	GND	GND	GND
D3	D3	D3	D3	2	36	$\overline{CD1}$	$\overline{CD1}$	$\overline{CD1}$	$\overline{CD1}$
D4	D4	D4	D4	3	37	D11	D11	D11	D11
D5	D5	D5	D5	4	38	D12	D12	D12	D12
D6	D6	D6	D6	5	39	D13	D13	D13	D13
D7	D7	D7	D7	6	40	D14	D14	D14	D14
$\overline{CE1}$	$\overline{CE1}$	$\overline{CE1}$	$\overline{CE1}$	7	41	D15	D15	D15	D15
A10	A10	A10	A10	8	42	$\overline{CE2}$	$\overline{CE2}$	$\overline{CE2}$	$\overline{CE2}$
\overline{OE}	\overline{OE}	\overline{OE}	\overline{OE}	9	43	NC	NC	NC	NC
A11	A11	A11	A11	10	44	NC	NC	NC	NC
A9	A9	A9	A9	11	45	NC	NC	NC	NC
A8	A8	A8	A8	12	46	A17	A17	A17	A17
A13	A13	A13	A13	13	47	A18	A18	A18	NC
A14	A14	A14	A14	14	48	A19	A19	NC	NC
WE/PGM	WE/PGM	WE/PGM	WE/PGM	15	49	A20	NC	NC	NC
NC	NC	NC	NC	16	50	NC	NC	NC	NC
VCC	VCC	VCC	VCC	17	51	VCC	VCC	VCC	VCC
VPP1	VPP1	VPP1	VPP1	18	52	VPP2	VPP2	VPP2	VPP2
A16	A16	A16	A16	19	53	NC	NC	NC	NC
A15	A15	A15	A15	20	54	NC	NC	NC	NC
A12	A12	A12	A12	21	55	NC	NC	NC	NC
A7	A7	A7	A7	22	56	NC	NC	NC	NC
A6	A6	A6	A6	23	57	NC	NC	NC	NC
A5	A5	A5	A5	24	58	NC	NC	NC	NC
A4	A4	A4	A4	25	59	NC	NC	NC	NC
A3	A3	A3	A3	26	60	NC	NC	NC	NC
A2	A2	A2	A2	27	61	REG	REG	REG	REG
A1	A1	A1	A1	28	62	NC	NC	NC	NC
A0	A0	A0	A0	29	63	NC	NC	NC	NC
D0	D0	D0	D0	30	64	D8	D8	D8	D8
D1	D1	D1	D1	31	65	D9	D9	D9	D9
D2	D2	D2	D2	32	66	D10	D10	D10	D10
WP	WP	WP	WP	33	67	$\overline{CD2}$	$\overline{CD2}$	$\overline{CD2}$	$\overline{CD2}$
GND	GND	GND	GND	34	68	GND	GND	GND	GND



functional block diagram

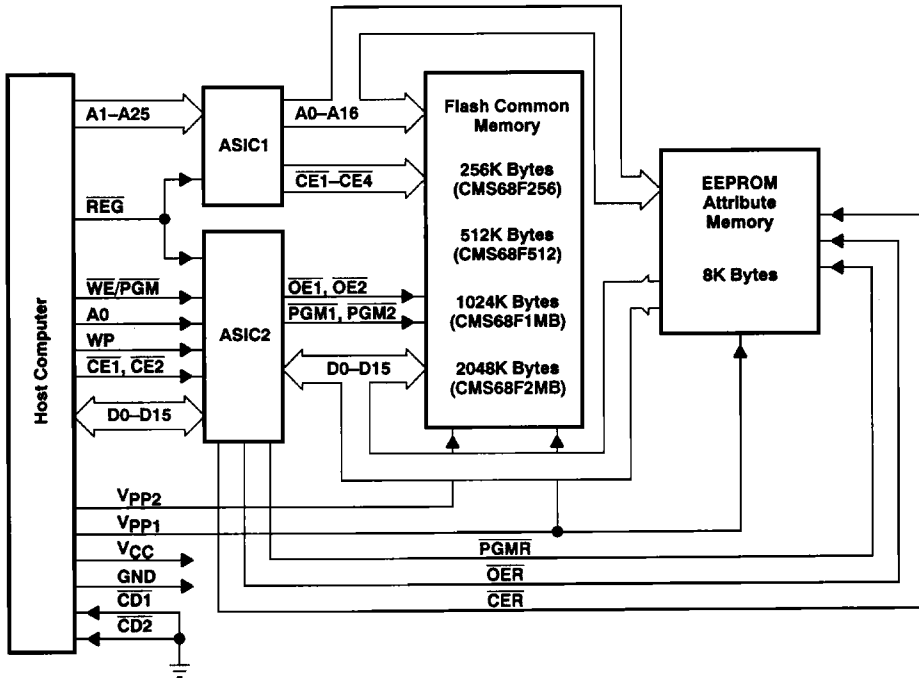

**CMS68F256, CMS68F512
CMS68F1MB, CMS68F2MB
FLASH MEMORY CARDS**

SMNS301A—NOVEMBER 1992

operation

There are seven modes of operation for the CMS68Fxxx described in the table below. The read mode requires a single 5-V supply.

operation table

FUNCTIONAL MODE	REG	CE2	CE1	A0	OE	WE / PGM	Vpp2	Vpp1	D15-D8	D7-D0
Standby	X	H	H	X	X	X	VCC	VCC	HI-Z	HI-Z
Read (x8)	H H	H H	L L	L H	L L	H H	VCC VCC	VCC VCC	HI-Z HI-Z	EV-BY OD-BY
Read (x16)	H	L	L	X	L	H	VCC	VCC	OD-BY	EV-BY
OD-BY Read	H	L	H	X	L	H	VCC	VCC	OD-BY	HI-Z
Write (x8)	H H	H H	L L	L H	H H	L L	VCC VPP	VPP VCC	XXX XXX	EV-BY OD-BY
Write (x16)	H	L	L	X	H	L	VPP	VPP	OD-BY	EV-BY
OD-BY Write	H	L	H	X	H	L	VPP	VCC	OD-BY	XXX

attribute memory read function

FUNCTIONAL MODE	REG	CE2	CE1	A0	OE	WE / PGM	Vpp2	Vpp1	D15-D8	D7-D0
Standby Mode	X	H	H	X	X	X	VCC	VCC	HI-Z	HI-Z
Byte access (8 bits)	L L	H H	L L	L H	L L	H H	VCC VCC	VCC VCC	HI-Z HI-Z	EV-BY Not Valid
Byte access (16 bits)	L	L	L	X	L	H	VCC	VCC	Not Valid	EV-BY
Odd-byte-only access	L	L	H	X	L	H	VCC	VCC	Not Valid	HI-Z

EV-BY = Even Byte
OD-BY = Odd Byte
HI-Z = High Impedance
X = V_{IL} or V_{IH}
H = High
L = Low

pin description

SYMBOL	FUNCTION
A0-A20	Address input lines, driven by the host, which enable direct addressing of up to 2 megabytes of memory. Signal A0 is not used in word access mode. Signal A20 is the most significant bit.
D0-D15	Bidirectional data bus The most significant bit is D15. Bit number and significance decrease downward to D0.
CE1, CE2	Active-low card enable signals driven by the host; CE1 is used to enable even bytes, CE2 for odd bytes. A multiplexing scheme based on A0, CE1, CE2 allows 8-bit hosts to access all data on D0-D7 if desired.
OE	Active-low signal, driven by the host, which is used to gate memory read data from the memory card.
WE/PGM	Programming enable signal
Vpp1	Programming voltage 1
Vpp2	Programming voltage 2
CD1, CD2	Card detect signals for proper memory card insertion detection. The signals are connected to ground internally on the memory card.
WP	Status signal of Write Protect switch on the memory card.
REG	When active, access to the memory card is limited to Attribute Memory used to record capacity and other configuration and attribute information.
VCC	Power supply
GND	Ground
NC	No internal connection



absolute maximum ratings over operating free-air temperature range (unless otherwise noted)†

Supply voltage range, V_{CC} (see Note 1)	- 0.6 V to 7 V
Supply voltage range, V_{PP} (see Note 1)	- 0.5 to 14 V
Input voltage range, (see Note 1)	- 0.5 to 6.5 V
Output voltage range, (see Note 1)	- 0.5 to V_{CC}
Operating free-air temperature range	- 0°C to 55°C
Storage temperature range	- 20°C to 65°C
Connector insertion cycles	10 000

† Stresses beyond those listed under "absolute maximum ratings" may cause permanent damage to the device. This is a stress rating only, and functional operation of the device at these or any other conditions beyond those indicated in the "recommended operating conditions" section of this specification is not implied. Exposure to absolute-maximum-rated conditions for extended periods may affect device reliability.

NOTE 1: Under absolute maximum ratings, voltage values are with respect to GND.

recommended operating conditions

		MIN	TYP	MAX	UNIT
V_{CC}	Supply voltage	4.75	5	5.25	V
V_{PPH}	Supply voltage	11.4		12.6	V
V_{PPL}	Supply voltage	Read Mode		6.5	V
V_{IH}	High-level input voltage	TTL		$V_{CC} + 0.3$	V
		CMOS		$V_{CC} + 0.5$	
V_{IL}	Low-level input voltage	TTL		0.8	V
		CMOS		GND + 0.2	
T_A	Operating free-air temperature	0		55	°C

electrical characteristics over full range of operating conditions

PARAMETER		TEST CONDITIONS	MIN	MAX	UNIT
V_{OH}	High-level output voltage (except WP)	$I_{OH} = 12 \text{ mA}, V_I = 0.9 V_{CC}$	3.7		V
		$I_{OH} = 1.2 \text{ mA}, V_I = 0.9 V_{CC}$	4.4		
V_{OL}	Low-level output voltage (except CD1, CD2)	$I_{OL} = 12 \text{ mA}, V_I = 0.1 V_{CC}$		0.5	V
		$I_{OL} = 1.2 \text{ mA}, V_I = 0.1 V_{CC}$		0.1	
I_I	Input current (leakage)	$V_I = 0 \text{ to } 5.25 \text{ V}$		±10	µA
I_O	Output current (leakage)	$V_O = 0 \text{ to } V_{CC}$		±10	µA
I_{PP1}	V_{PP} supply current	$V_{PP} = V_{CC} = 5.25 \text{ V}$		80	mA
I_{PP2}	V_{PP} write current	$V_{PP} = V_{PPH}$, Write in progress		60	mA
I_{PP3}	V_{PP} write verify current	$V_{PP} = V_{PPH}$, Erasure in progress		12	µA
I_{PP4}	V_{PP} erase verify current	$V_{PP} = V_{PPH}$, Erasure verify in progress		12	mA
I_{PP5}	V_{PP} leakage current	$V_{PP} \leq V_{CC}$		±80	µA
I_{CC1}	V_{CC} supply current (standby)	TTL-input level	$\overline{CE}x = V_{IH}, V_{CC} = 5.25 \text{ V}$	25	mA
		CMOS-input level	$\overline{CE}x = V_{CC} \pm 0.2 \text{ V}, V_{CC} = 5.25 \text{ V}$	20	
I_{CC2}	V_{CC} supply current (active, output open)	$\overline{CE}x = V_{IL}, V_{CC} = 5.25 \text{ V}, I_{OUT} = 0 \text{ mA}, f = 6 \text{ MHz}$		80	mA

**CMS68F256, CMS68F512
CMS68F1MB, CMS68F2MB
FLASH MEMORY CARDS**

SMNS301A—NOVEMBER 1992

capacitance over recommended ranges of supply voltage and free-air temperature, $f = 1 \text{ MHz}$ †

PARAMETER	TEST CONDITIONS	MIN	TYP‡	MAX	UNIT
C_I Input capacitance	$V_I = 0 \text{ V}$, $f = 1 \text{ MHz}$			8	pF
C_O Output capacitance	$V_O = 0 \text{ V}$, $f = 1 \text{ MHz}$			16	pF

† Capacitance measurements are made on sample basis only.

‡ All typical values are at $T_A = 25^\circ\text{C}$ and nominal voltages.

switching characteristics for read-only operations for attribute memory over recommended ranges of supply voltage and operating free-air temperature (see Notes 2 and 3)

PARAMETER	TEST CONDITIONS (SEE NOTES 2 & 3)	MIN	MAX	UNIT
$t_{a(A)}$ Access time from address	$C_L = 100 \text{ pF}$, 1 Series 74 TTL load, Input $t_r \leq 20 \text{ ns}$, Input $t_f \leq 20 \text{ ns}$		200	ns
$t_{a(E)}$ Access time ROM chip enable			200	ns
$t_{en(G)}$ Output enable time from \overline{OE}			100	ns
t_{dis} Output disable time from \overline{OE} or \overline{CEx} , whichever occurs first†		0	60	ns
$t_{v(A)}$ Output data valid time after change of address \overline{CEx} or \overline{OE} whichever occurs first		0		ns

† Value calculated from 0.5-V delta to measured output level.

NOTES: 2. For all switching characteristics the input pulse levels are 0.4 V to 2.4 V. Timing measurements are made at 2 V for logic high and 0.8 V for logic low (reference input/output wave forms for timing parameters).

3. Common test conditions apply for t_{dis} except during programming.

timing requirements for read-only operations over recommended ranges of supply voltage and operating free-air temperature (see Note 4)

PARAMETER	CHARACTERISTICS	MIN	MAX	UNIT
t_{avav} / t_{rc}	Read cycle time	250		ns
t_{elqv} / t_{ce}	Chip enable access time		250	ns
t_{avqv} / t_{acc}	Address access time		250	ns
t_{glqv} / t_{oe}	Output enable access time		120	ns
t_{elox} / t_{iz}	Chip enable to output in low-Z	5		ns
t_{ehqz}	Chip disable to output in high-Z		60	ns
t_{glqx} / t_{oiz}	Output enable to output in low-Z	5		ns
t_{ghqz} / t_{df}	Output disable to output in high-Z		60	ns
t_{oh}	Output hold from address \overline{CE} or \overline{OE} change (see Note 5)	5		ns
t_{whgl}	Write recovery time before read	6		μs

NOTES: 4. Rise/fall time $\leq 10 \text{ ns}$.

5. Read timing parameters during read/write operations are the same as during read-only operations.



timing requirements for write/erase operations over recommended ranges of supply voltage and operating free-air temperature (see Notes 4 and 5)

PARAMETER	CHARACTERISTICS	MIN	MAX	UNIT
t _{avav} / t _{wc}	Write cycle time	250		ns
t _{avwi} / t _{as}	Address setup time	0		ns
t _{wiax} / t _{ah}	Address hold time	100		ns
t _{dvwH} / t _{ds}	Data setup time	80		ns
t _{whdx} / t _{dh}	Data hold time	30		ns
t _{whgl}	Write recovery time before read	6		μs
t _{ghwi}	Read recovery time before read	0		μs
t _{wioz}	Output high-Z from write enable	5		ns
t _{whox}	Output low-Z from write enable		60	ns
t _{elwi} / t _{cs}	Chip enable setup time before write	40		ns
t _{wheh} / t _{ch}	Chip enable hold time	0		ns
t _{wiwh} / t _{wp}	Write pulse duration	100		ns
t _{whwi} / t _{wph}	Write pulse duration high	20		ns
t _{whwh1}	Duration of write operation (see Note 6)	10		μs
t _{whwh2}	Duration of erase operation (see Note 6)	9.5		ms
t _{pel}	V _{pp} setup time to chip enable low	100		ns

NOTES: 4. Rise/fall time ≤ 10 ns.

5. Read timing parameters during read/write operations are the same as during read-only operations. Refer to timing requirements for Read Operations.

6. The integrated stop timer terminates the write/erase operations, thereby eliminating the need for a maximum specification.

alternative \overline{CE} -controlled writes over recommended ranges of supply voltage and operating free-air temperature

PARAMETER	CHARACTERISTICS	MIN	MAX	UNIT
t _{avav}	Write cycle time	250		ns
t _{avel}	Address setup time	0		ns
t _{elax}	Address hold time	100		ns
t _{dveh}	Data setup time	80		ns
t _{ehdx}	Data hold time	30		ns
t _{ehgl}	Write recovery time before read	6		μs
t _{ghel}	Read recovery time before read	0		μs
t _{wiel}	Write enable setup time before chip-enable	0		ns
t _{ehwh}	Write enable hold time	0		ns
t _{eleh}	Write pulse duration (see Note 7)	100		ns
t _{ehel}	Write pulse duration high	20		ns
t _{pel}	V _{pp} setup time to chip enable low	100		ns

NOTE 7: Chip Enable Controlled Writes: Write operations are driven by the valid condition of Chip Enable and Write Enable. In systems where Chip Enable defines the write pulse duration (with a longer Write Enable timing waveform) all set-up, hold, and inactive Write Enable times should be measured relative to the Chip Enable waveform.

programming flowchart: write algorithm for byte-wide mode

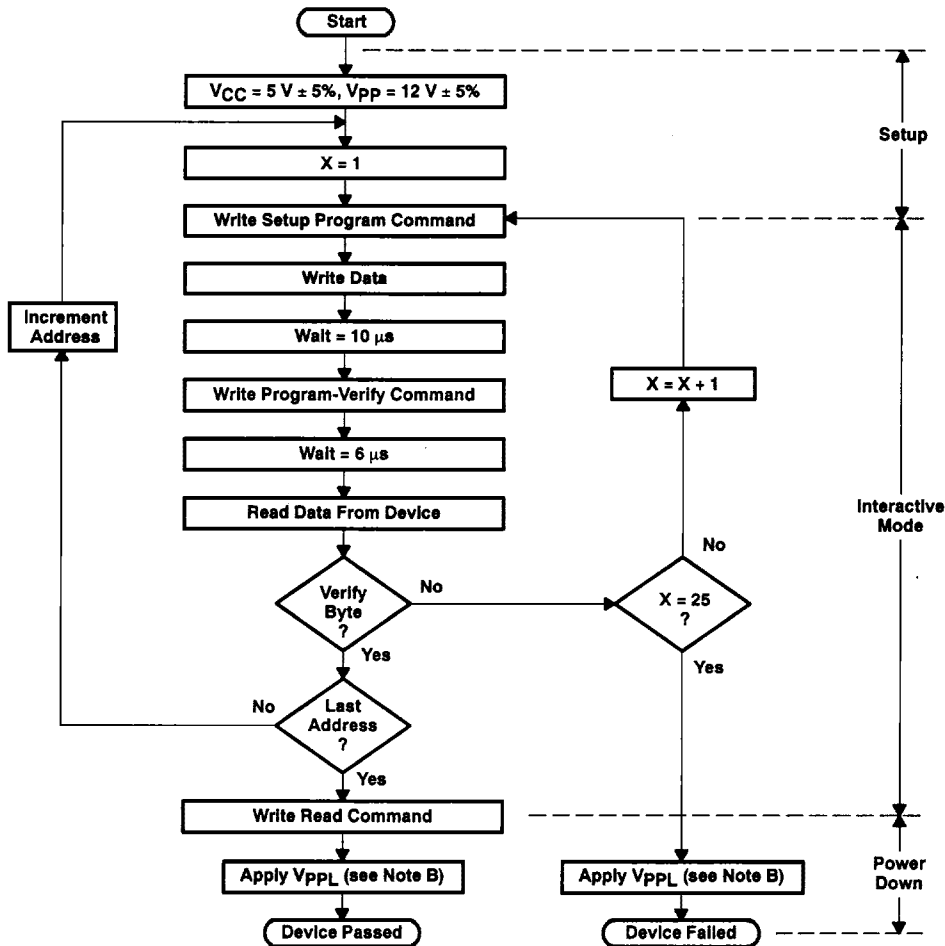

BUS OPERATION	COMMAND	COMMENTS
Initialize Address Standby		Wait for Vpp ramp to VppH (see Note A) Initialize Pulse Count
Write	Setup Program	Data = 40h
Write	Write-Data	Valid Address Data
Standby		Wait = 10 µs
Write	Program Verify	Data = C0h; Ends Program Operation
Standby		Wait = 5 µs
Read		Read Byte to Verify Programming; Compare Output to Expected Output
Write	Read	Data = 00h; Register Reset for Read Operations
Standby		Wait for Vpp Ramp to VppL (see Note B)

NOTES: A. Refer to the recommended operating conditions for the value of VppH.
B. Refer to the recommended operating conditions for the value of VppL.

flash-erase flowchart: erase algorithm for byte-wide mode

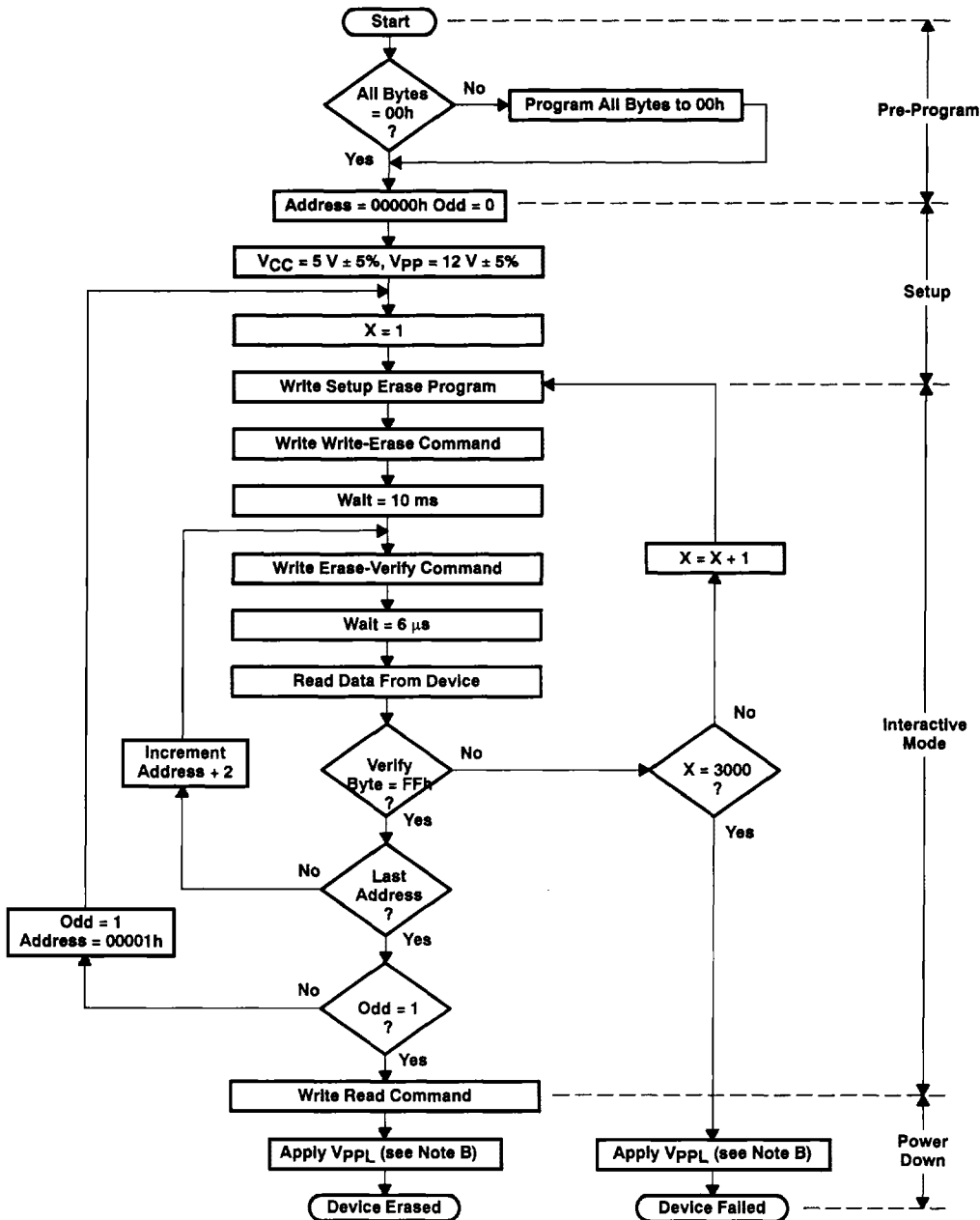

NOTES: A. Refer to the recommended operating conditions for the value of V_{ppH} .
 B. Refer to the recommended operating conditions for the value of V_{ppL} .

**CMS68F256, CMS68F512
CMS68F1MB, CMS68F2MB
FLASH MEMORY CARDS**

SMNS301A-NOVEMBER 1992

flash-erase flowchart: erase algorithm for byte-wide mode (continued)

BUS OPERATION	COMMAND	COMMENTS
		Entire Memory Must = 00h Before Erasure Use Fastwrite Programming Algorithm
		Initialize Addresses
Standby		Wait = V_{pp} Ramp to V_{ppH} (see Note A)
		Initialize Pulse Count
Write	Setup Erase	Data = 20h
Write	Erase	Data = 20h
Standby		Wait = 9.5 ms
Write	Erase Verify	Address = Byte to Verify; Data = A0h; Ends the Erase Operation
Standby		Wait = 6 μ s
Read		Read Byte to Verify Erasure; Compare Output to FFh
Write	Read	Data = 00h; Register Reset for Read Operations
Standby		Wait for V_{pp} Ramp to V_{ppL} (see Note B)

NOTES: A. Refer to the recommended operating conditions for the value of V_{ppH} .
B. Refer to the recommended operating conditions for the value of V_{ppL} .



programming flowchart: write algorithm for word-wide mode

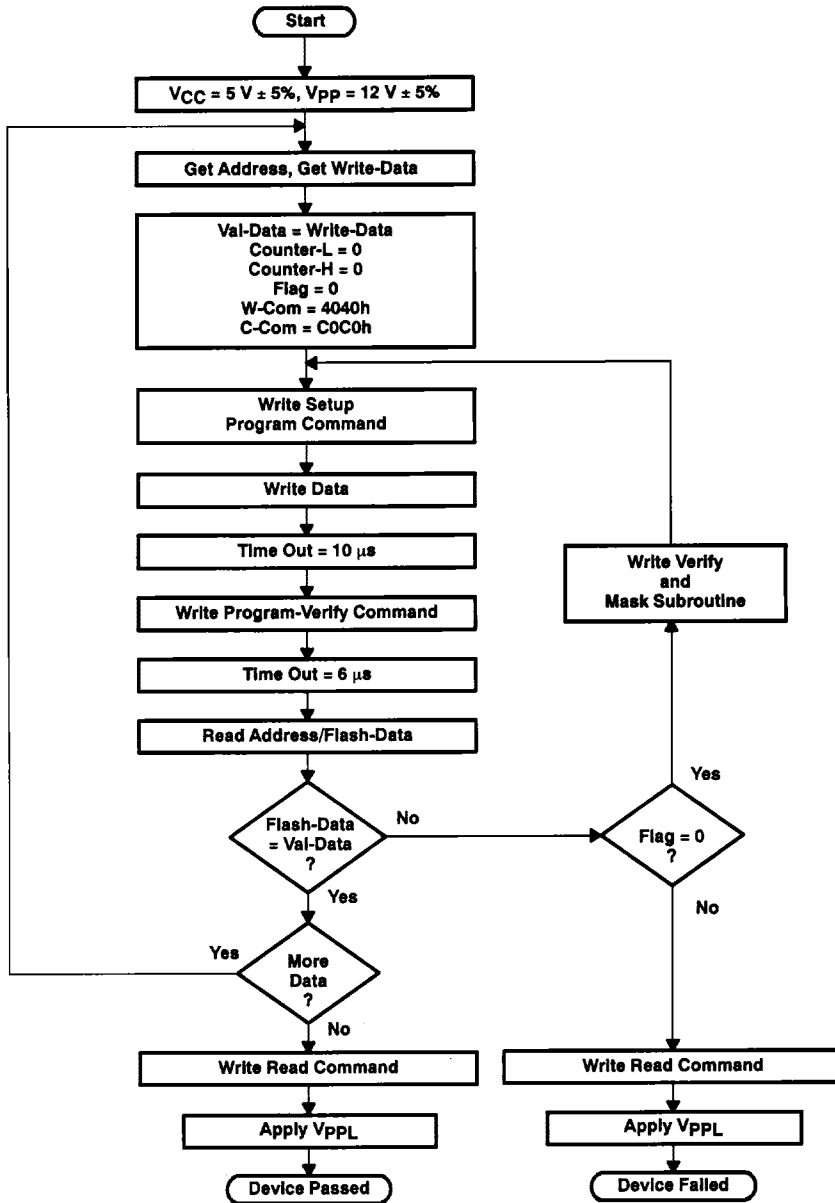

**CMS68F256, CMS68F512
CMS68F1MB, CMS68F2MB
FLASH MEMORY CARDS**
SMNS301A—NOVEMBER 1992

write verify and mask subroutine for read-write mode

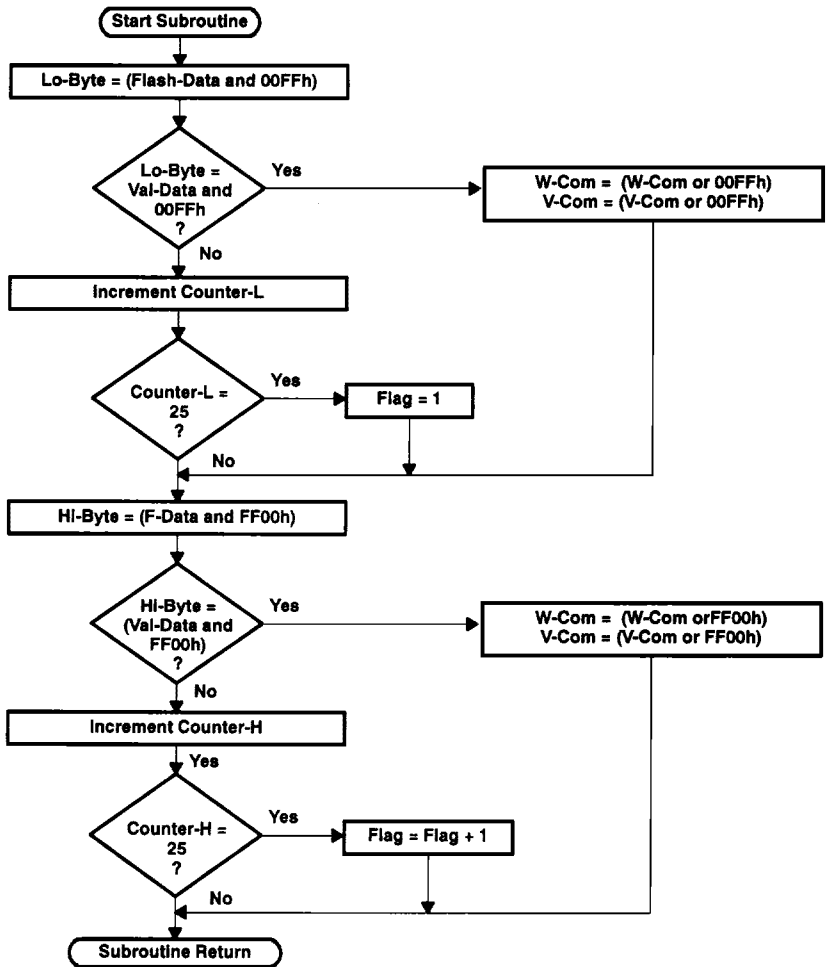

BUS OPERATION	COMMAND	COMMENTS
Write	Setup Program	Data = W-Com
Write	Write-Data	Valid Address Data (Write-Data)
Write	Program-Verify	Data = C-Com; Ends Programs Operations

erase algorithm for word-wide mode

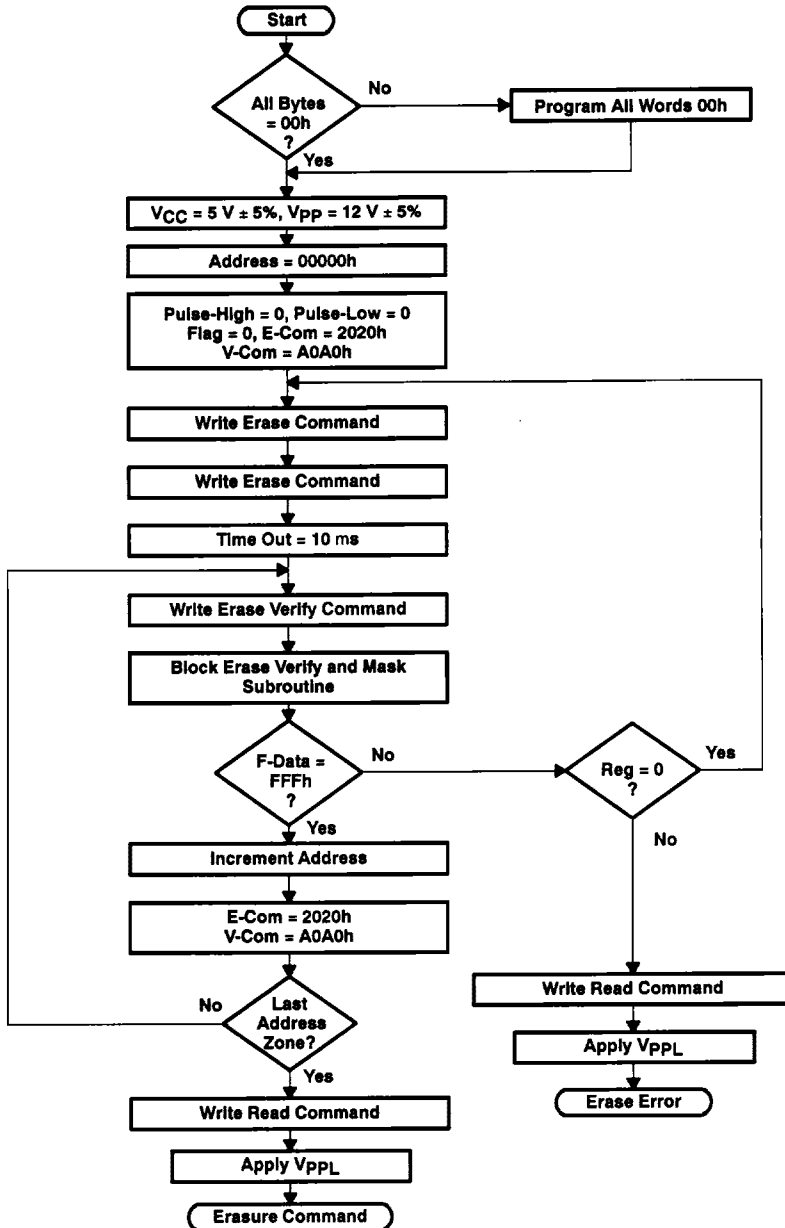

BUS OPERATION	COMMAND	COMMENTS
Write	Erase	Data = 2020h
Write	Erase-Verify	Data = A0A0h

block erase verify and mask subroutine

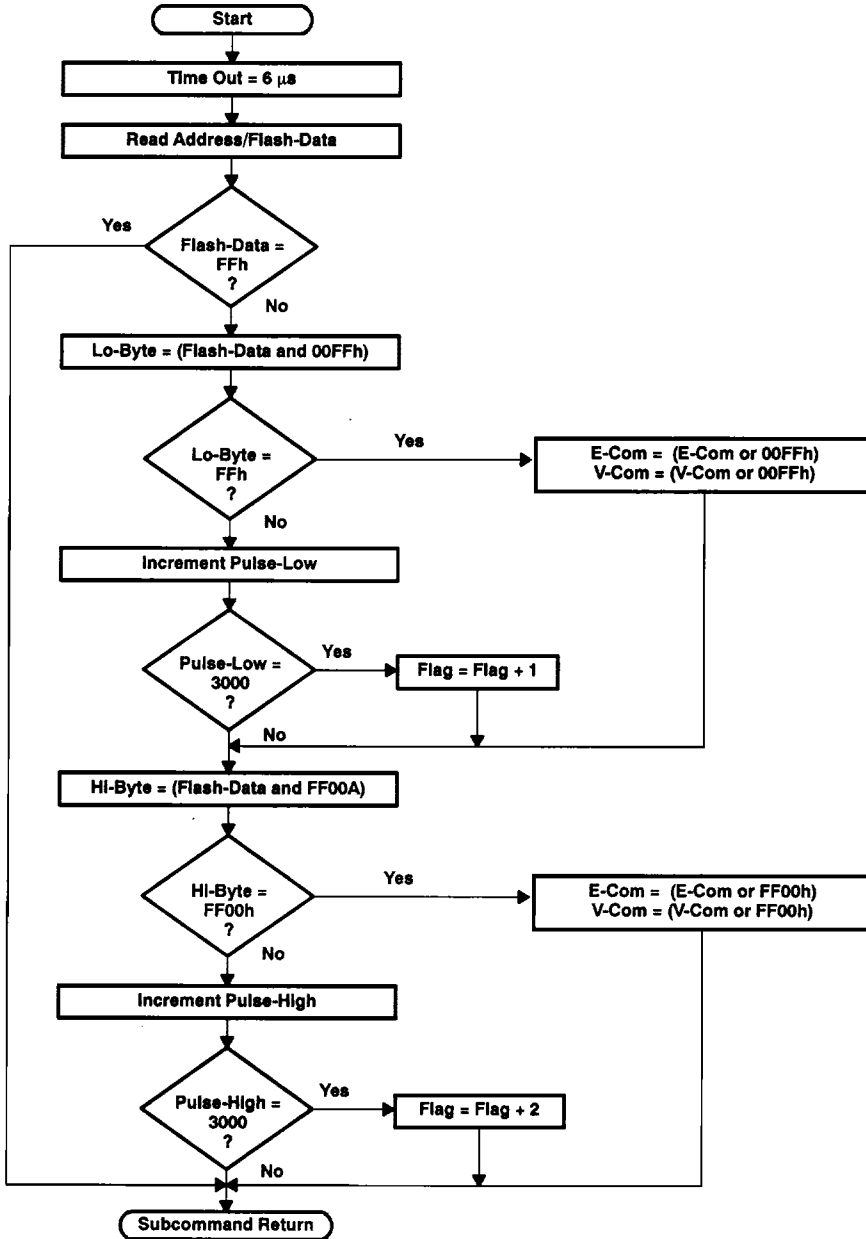

PARAMETER MEASUREMENT INFORMATION

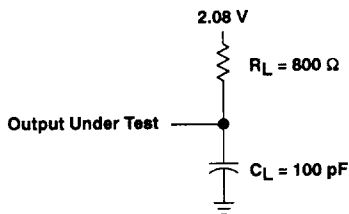
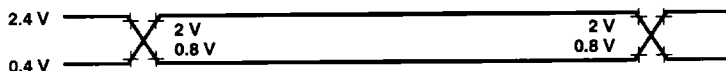

Figure 1. Load Circuit for Timing Parameters

Input/output wave forms for timing parameters



AC testing inputs are driven at 2.4 V for logic high and 0.4 V for logic low. Timing measurements are made at 2 V for logic high and 0.8 V for logic low for both inputs and outputs.

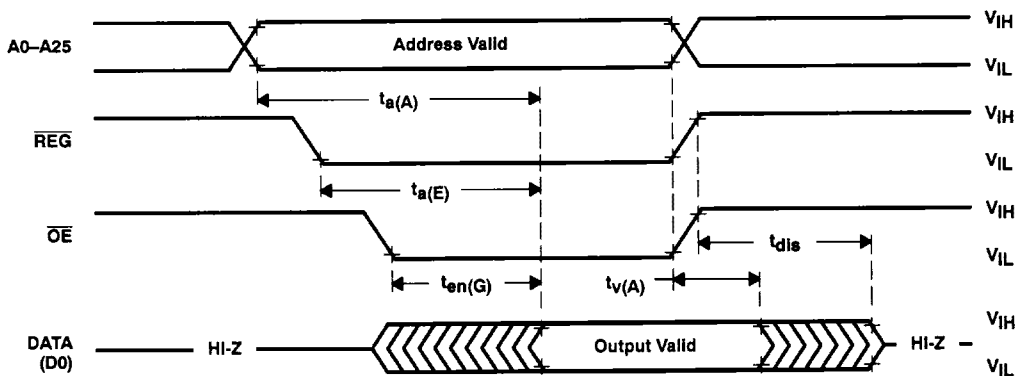
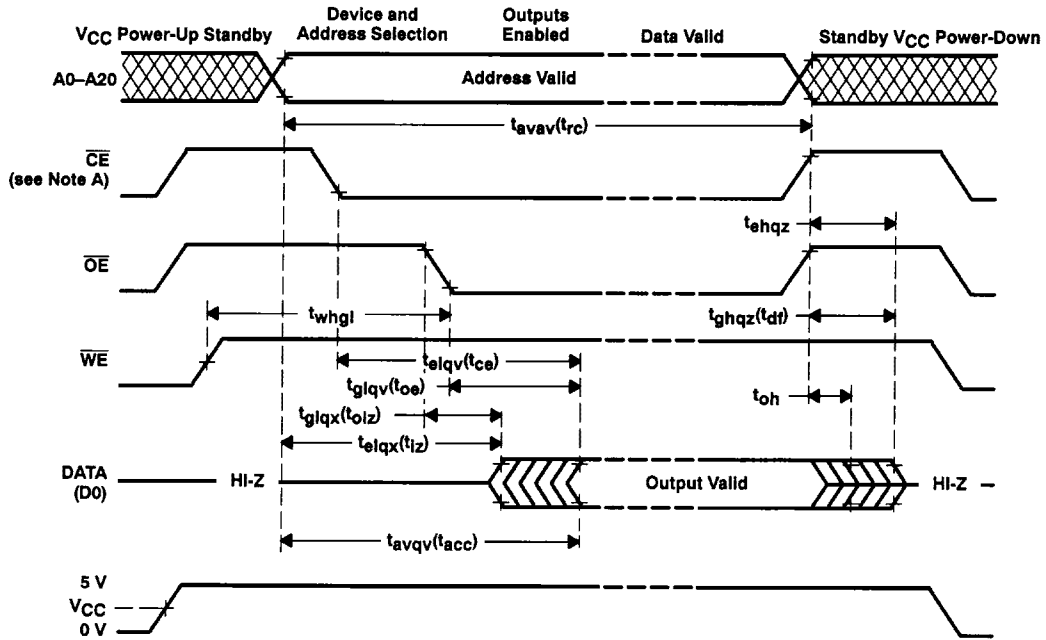

Figure 2. Attribute Memory Read Cycle Timing

**CMS68F256, CMS68F512
CMS68F1MB, CMS68F2MB
FLASH MEMORY CARDS**

SMNS301A—NOVEMBER 1992

PARAMETER MEASUREMENT INFORMATION



NOTE A: \overline{CE} refers to $\overline{CE1}$ and $\overline{CE2}$.

Figure 3. Read Operations Timing

PARAMETER MEASUREMENT INFORMATION

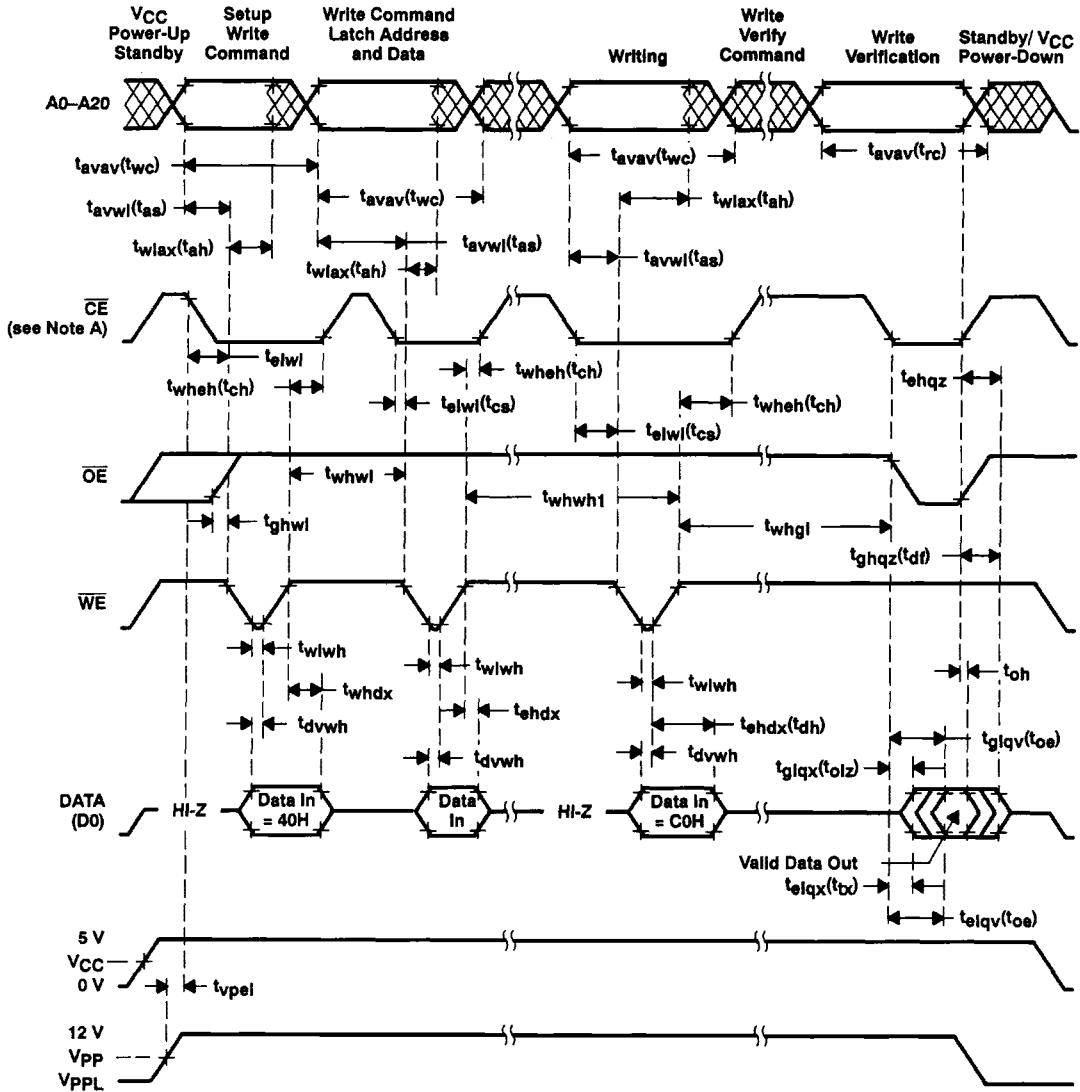

NOTE A: \overline{CE} refers to $\overline{CE1}$ and $\overline{CE2}$.

Figure 4. Write Operations Timing

PARAMETER MEASUREMENT INFORMATION

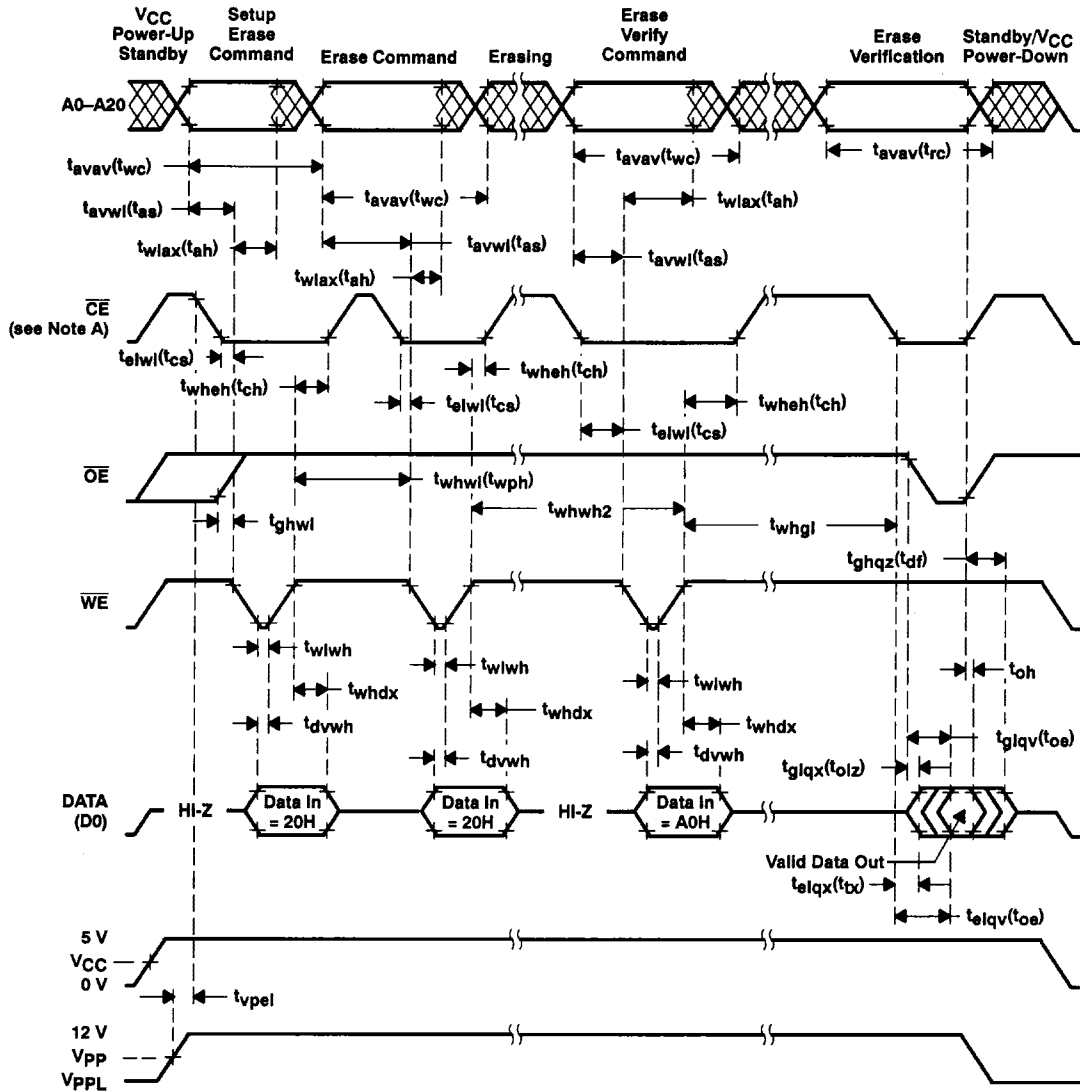

NOTE A: \overline{CE} refers to $\overline{CE1}$ and $\overline{CE2}$.

Figure 5. Erase Operations Timing

**CMS68F256, CMS68F512
CMS68F1MB, CMS68F2MB
FLASH MEMORY CARDS**

SMNS301A—NOVEMBER 1992

