



ICS8521I-03

Low Skew, 1-to-9 DIFFERENTIAL-TO-LVHSTL FANOUT BUFFER

GENERAL DESCRIPTION

The ICS8521I-03 is a low skew, 1-to-9 Differential-to-LVHSTL Fanout Buffer. The ICS8521I-03 has two selectable clock inputs. Redundant clock pairs, CLK0, nCLK0 and CLK1, nCLK1 can accept most standard differential input levels. The clock enable is internally synchronized to eliminate runt pulses on the outputs during asynchronous assertion/deassertion of the clock enable pin.

Guaranteed output skew and part-to-part skew characteristics make the ICS8521I-03 ideal for today's most advanced applications, such as IA64 and static RAMs.

FEATURES

- 9 LVHSTL outputs
- Redundant differential CLK0, nCLK0 and CLK1, nCLK1 inputs
- CLKx, nCLKx pairs can accept the following differential input levels: LVPECL, LVDS, LVHSTL, SSTL, HCSL
- Maximum output frequency: 500MHz
- Output skew: 50ps (maximum)
- Part-to-part skew: 250ps (maximum)
- Propagation delay: 1.6ns (maximum)
- $V_{OH} = 1V$ (maximum)
- 3.3V core, 1.8V output operating supply voltages
- -40°C to 85°C ambient operating temperature

BLOCK DIAGRAM

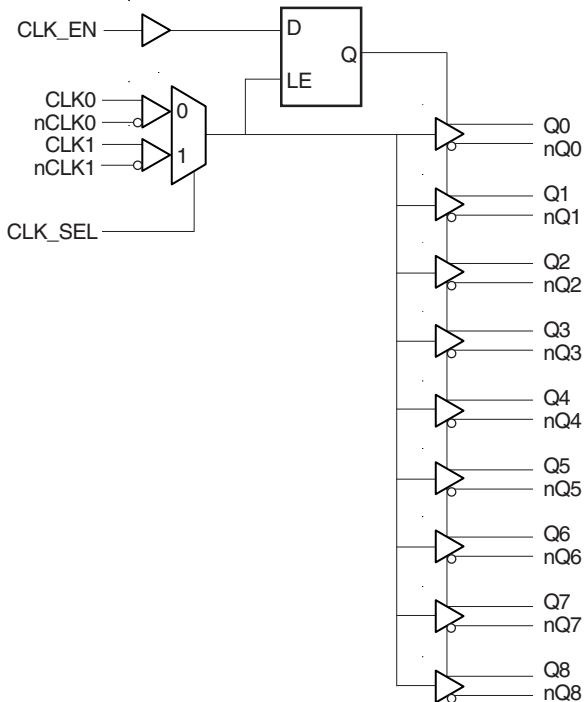

PIN ASSIGNMENT

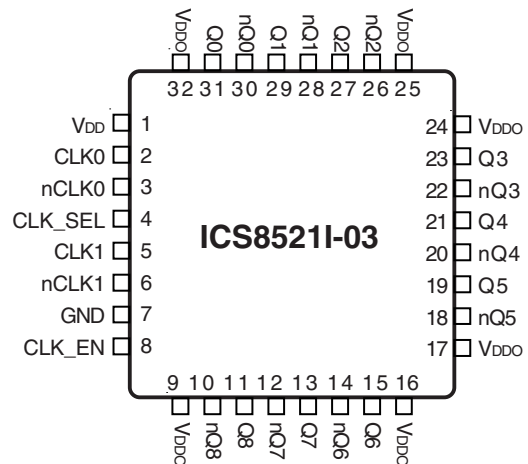

32-Lead LQFP
7mm x 7mm x 1.4mm Package Body
Y Package
Top View



TABLE 1. PIN DESCRIPTIONS

| Number | Name | Type | | Description |
|--------------------------|------------------|--------|----------|---|
| 1 | V _{DD} | Power | | Core supply pin. |
| 2 | CLK0 | Input | Pulldown | Non-inverting differential clock input. |
| 3 | nCLK0 | Input | Pullup | Inverting differential clock input. |
| 4 | CLK_SEL | Input | Pulldown | Clock select input. When HIGH, selects CLK1, nCLK1 inputs. When LOW, selects CLK0, nCLK0. LVTTTL / LVCMOS interface levels. |
| 5 | CLK1 | Input | Pulldown | Non-inverting differential clock input. |
| 6 | nCLK1 | Input | Pullup | Inverting differential clock input. |
| 7 | GND | Power | | Power supply ground. |
| 8 | CLK_EN | Input | Pullup | Synchronizing clock enable. When HIGH, clock outputs follow clock input. When LOW, Q outputs are forced low, nQ outputs are forced high. LVCMOS /LVTTTL interface levels. |
| 9, 16, 17, 24, 25, 32 | V _{DDO} | Power | | Output supply pins. |
| 10, 11 | nQ8, Q8 | Output | | Differential output pair. LVHSTL interface level. |
| 12, 13 | nQ7, Q7 | Output | | Differential output pair. LVHSTL interface level. |
| 14, 15 | nQ6, Q6 | Output | | Differential output pair. LVHSTL interface level. |
| 18, 19 | nQ5, Q5 | Output | | Differential output pair. LVHSTL interface level. |
| 20, 21 | nQ4, Q4 | Output | | Differential output pair. LVHSTL interface level. |
| 22, 23 | nQ3, Q3 | Output | | Differential output pair. LVHSTL interface level. |
| 26, 27 | nQ2, Q2 | Output | | Differential output pair. LVHSTL interface level. |
| 28, 29 | nQ1, Q1 | Output | | Differential output pair. LVHSTL interface level. |
| 30, 31 | nQ0, Q0 | Output | | Differential output pair. LVHSTL interface level. |

NOTE: *Pullup* and *Pulldown* refer to internal input resistors. See Table 2, Pin Characteristics, for typical values.

TABLE 2. PIN CHARACTERISTICS

| Symbol | Parameter | Test Conditions | Minimum | Typical | Maximum | Units |
|-----------------------|-------------------------|-----------------|---------|---------|---------|-------|
| C _{IN} | Input Capacitance | | | 4 | | pF |
| R _{PULLUP} | Input Pullup Resistor | | | 51 | | KΩ |
| R _{PULLDOWN} | Input Pulldown Resistor | | | 51 | | KΩ |



TABLE 3A. CONTROL INPUT FUNCTION TABLE

| Inputs | | | Outputs | |
|--------|---------|------------------|---------------|----------------|
| CLK_EN | CLK_SEL | Selected Sourced | Q0:Q8 | nQ0:nQ8 |
| 0 | 0 | CLK0, nCLK0 | Disabled; LOW | Disabled; HIGH |
| 0 | 1 | CLK1, nCLK1 | Disabled; LOW | Disabled; HIGH |
| 1 | 0 | CLK0, nCLK0 | Enabled | Enabled |
| 1 | 1 | CLK1, nCLK1 | Enabled | Enabled |

After CLK_EN switches, the clock outputs are disabled or enabled following a rising and falling input clock edge as shown in *Figure 1*.

In the active mode, the state of the outputs are a function of the CLKx, nCLKx inputs as described in *Table 3B*.

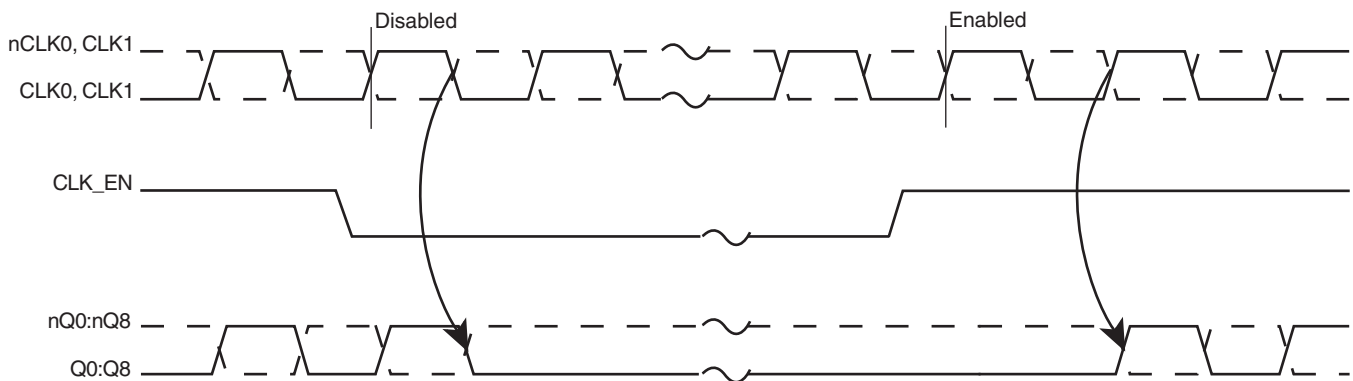

FIGURE 1. CLK_EN TIMING DIAGRAM

TABLE 3B. CLOCK INPUT FUNCTION TABLE

| Inputs | | Outputs | | Input to Output Mode | Polarity |
|----------------|----------------|---------|---------|------------------------------|---------------|
| CLK0 or CLK1 | nCLK0 or nCLK1 | Q0:Q8 | nQ0:nQ8 | | |
| 0 | 1 | LOW | HIGH | Differential to Differential | Non Inverting |
| 1 | 0 | HIGH | LOW | Differential to Differential | Non Inverting |
| 0 | Biased; NOTE 1 | LOW | HIGH | Single Ended to Differential | Non Inverting |
| 1 | Biased; NOTE 1 | HIGH | LOW | Single Ended to Differential | Non Inverting |
| Biased; NOTE 1 | 0 | HIGH | LOW | Single Ended to Differential | Inverting |
| Biased; NOTE 1 | 1 | LOW | HIGH | Single Ended to Differential | Inverting |

NOTE 1: Please refer to the Application Information "Wiring the Differential Input to Accept Single Ended Levels".



ICS8521I-03

LOW SKEW, 1-TO-9 DIFFERENTIAL-TO-LVHSTL FANOUT BUFFER

ABSOLUTE MAXIMUM RATINGS

| | |
|--|---------------------------|
| Supply Voltage, V_{DD} | 4.6V |
| Inputs, V_I | -0.5V to $V_{DD} + 0.5V$ |
| Outputs, V_O | -0.5V to $V_{DDO} + 0.5V$ |
| Package Thermal Impedance, θ_{JA} | 47.9°C/W (0 lfpm) |
| Storage Temperature, T_{STG} | -65°C to 150°C |

NOTE: Stresses beyond those listed under Absolute Maximum Ratings may cause permanent damage to the device. These ratings are stress specifications only. Functional operation of product at these conditions or any conditions beyond those listed in the *DC Characteristics* or *AC Characteristics* is not implied. Exposure to absolute maximum rating conditions for extended periods may affect product reliability.

TABLE 4A. POWER SUPPLY DC CHARACTERISTICS, $V_{DD} = 3.3V \pm 5\%$, $V_{DDO} = 1.8V \pm 0.2V$, $T_A = -40^\circ C$ TO $85^\circ C$

| Symbol | Parameter | Test Conditions | Minimum | Typical | Maximum | Units |
|-----------|-----------------------|-----------------|---------|---------|---------|-------|
| V_{DD} | Core Supply Voltage | | 3.135 | 3.3 | 3.465 | V |
| V_{DDO} | Output Supply Voltage | | 1.6 | 1.8 | 2.0 | V |
| I_{DD} | Power Supply Current | | | | 95 | mA |

TABLE 4B. LVCMOS/LVTTL DC CHARACTERISTICS, $V_{DD} = 3.3V \pm 5\%$, $V_{DDO} = 1.8V \pm 0.2V$, $T_A = -40^\circ C$ TO $85^\circ C$

| Symbol | Parameter | Test Conditions | Minimum | Typical | Maximum | Units |
|----------|--------------------|-----------------|--------------------------------|---------|----------------|---------|
| V_{IH} | Input High Voltage | | 2 | | $V_{DD} + 0.3$ | V |
| V_{IL} | Input Low Voltage | | -0.3 | | 0.8 | V |
| I_{IH} | Input High Current | CLK_EN | $V_{IN} = V_{DD} = 3.465V$ | | 5 | μA |
| | | CLK_SEL | $V_{IN} = V_{DD} = 3.465V$ | | 150 | μA |
| I_{IL} | Input Low Current | CLK_EN | $V_{IN} = 0V, V_{DD} = 3.465V$ | -150 | | μA |
| | | CLK_SEL | $V_{IN} = 0V, V_{DD} = 3.465V$ | -5 | | μA |

TABLE 4C. DIFFERENTIAL DC CHARACTERISTICS, $V_{DD} = 3.3V \pm 5\%$, $V_{DDO} = 1.8V \pm 0.2V$, $T_A = -40^\circ C$ TO $85^\circ C$

| Symbol | Parameter | Test Conditions | Minimum | Typical | Maximum | Units |
|-----------|---|-----------------|--------------------------------|---------|-----------------|---------|
| I_{IH} | Input High Current | CLKx | $V_{IN} = V_{DD} = 3.465V$ | | 150 | μA |
| | | nCLKx | $V_{IN} = V_{DD} = 3.465V$ | | 5 | μA |
| I_{IL} | Input Low Current | CLKx | $V_{IN} = 0V, V_{DD} = 3.465V$ | -5 | | μA |
| | | nCLKx | $V_{IN} = 0V, V_{DD} = 3.465V$ | -150 | | μA |
| V_{PP} | Peak-to-Peak Input Voltage | | 0.15 | | 1.3 | V |
| V_{CMR} | Common Mode Input Voltage; NOTE 1, 2 | | 0.5 | | $V_{DD} - 0.85$ | V |

NOTE 1: For single ended applications, the maximum input voltage for CLKx and nCLKx is $V_{DD} + 0.3V$.

NOTE 2: Common mode voltage is defined as V_{IH} .



ICS8521I-03

LOW SKEW, 1-TO-9 DIFFERENTIAL-TO-LVHSTL FANOUT BUFFER

TABLE 4D. LVHSTL DC CHARACTERISTICS, $V_{DD} = 3.3V \pm 5\%$, $V_{DDO} = 1.8V \pm 0.2V$, $T_A = -40^\circ C$ TO $85^\circ C$

| Symbol | Parameter | Test Conditions | Minimum | Typical | Maximum | Units |
|-------------|-----------------------------------|-----------------|---------|---------|---------|-------|
| V_{OH} | Output High Voltage; NOTE 1 | | 0.7 | | 1.0 | V |
| V_{OL} | Output Low Voltage; NOTE 1 | | 0 | | 0.4 | V |
| V_{SWING} | Peak-to-Peak Output Voltage Swing | | 0.4 | | 1.0 | V |

NOTE 1: Outputs terminated with 50Ω to ground.

TABLE 5. AC CHARACTERISTICS, $V_{DD} = 3.3V \pm 5\%$, $V_{DDO} = 1.8V \pm 0.2V$, $T_A = -40^\circ C$ TO $85^\circ C$

| Symbol | Parameter | Test Conditions | Minimum | Typical | Maximum | Units |
|--------------|------------------------------|--------------------------|---------|---------|---------|-------|
| f_{MAX} | Output Frequency | | | | 500 | MHz |
| t_{PD} | Propagation Delay; NOTE 1 | | 1.0 | | 1.6 | ns |
| $t_{sk(o)}$ | Output Skew; NOTE 2, 4 | | | | 50 | ps |
| $t_{sk(pp)}$ | Part-to-Part Skew; NOTE 3, 4 | | | | 250 | ps |
| t_R / t_F | Output Rise/Fall Time | | 200 | | 700 | ps |
| odc | Output Duty Cycle | $f \leq 266MHz$ | 48 | | 52 | % |
| | | $266MHz < f \leq 500MHz$ | 45 | | 55 | % |

NOTE 1: Measured from the differential input crossing point to the differential output crossing point.

NOTE 2: Defined as skew between outputs at the same supply voltage and with equal load conditions. Measured at the output differential cross points.

NOTE 3: Defined as skew between outputs on different devices operating at the same supply voltages and with equal load conditions. Using the same type of inputs on each device, the outputs are measured at the differential cross points.

NOTE 4: This parameter is defined in accordance with JEDEC Standard 65.

PARAMETER MEASUREMENT INFORMATION

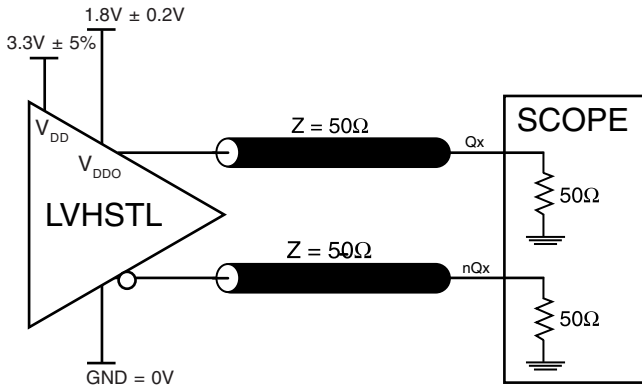

3.3V CORE/1.8V OUTPUT LOAD AC TEST CIRCUIT

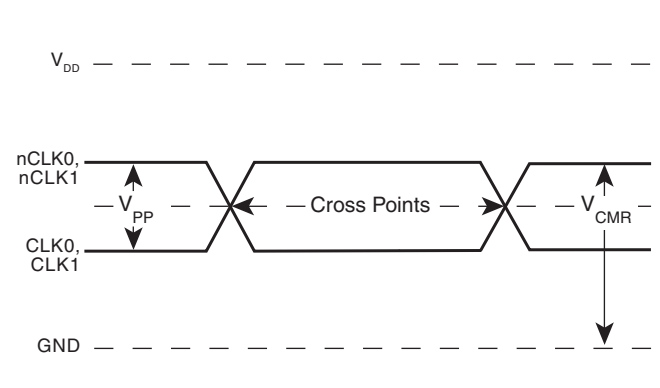

DIFFERENTIAL INPUT LEVEL

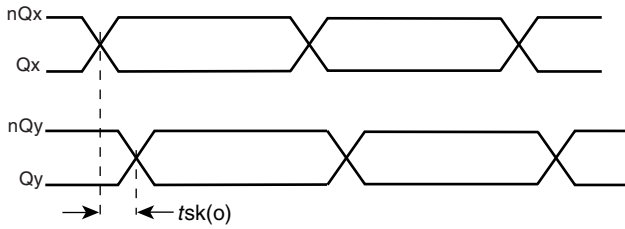

OUTPUT SKEW

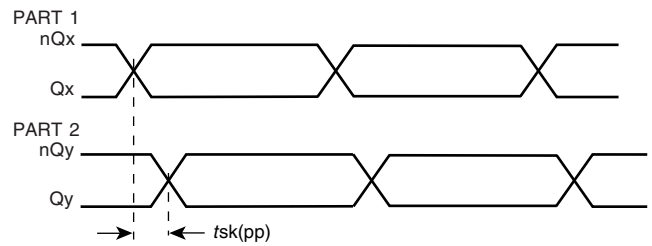

PART-TO-PART SKEW

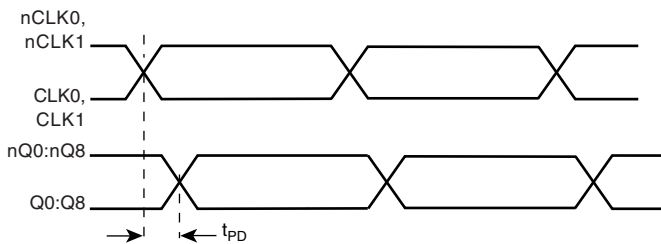

PROPAGATION DELAY



OUTPUT RISE/FALL TIME

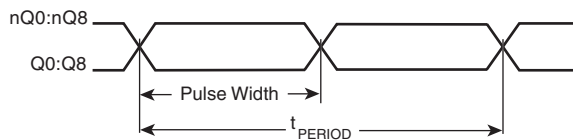

$$odc = \frac{t_{PW}}{t_{PERIOD}}$$

odc & t_{PERIOD}

APPLICATION INFORMATION

WIRING THE DIFFERENTIAL INPUT TO ACCEPT SINGLE ENDED LEVELS

Figure 2 shows how the differential input can be wired to accept single ended levels. The reference voltage $V_{REF} = V_{DD}/2$ is generated by the bias resistors R1, R2 and C1. This bias circuit should be located as close as possible to the input pin. The ratio

of R1 and R2 might need to be adjusted to position the V_{REF} in the center of the input voltage swing. For example, if the input clock swing is only 2.5V and $V_{DD} = 3.3V$, V_{REF} should be 1.25V and $R2/R1 = 0.609$.

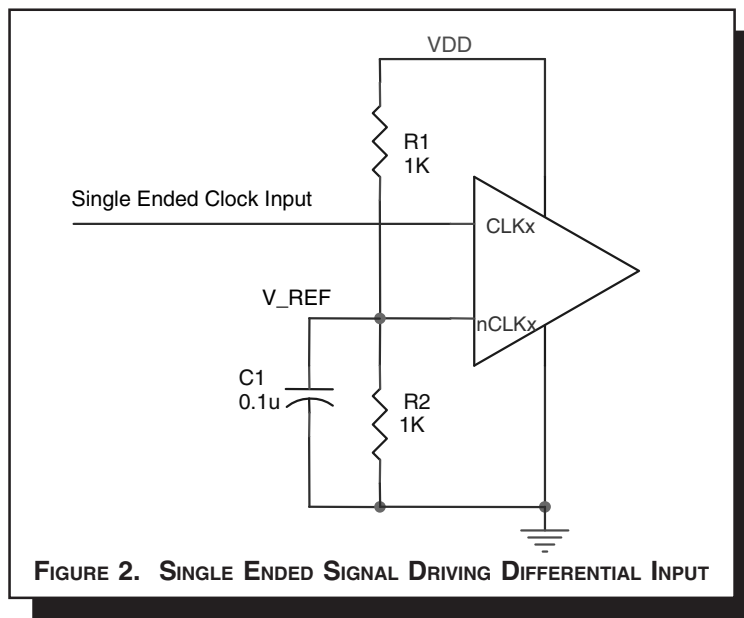

SCHEMATIC EXAMPLE

This application note provides general design guide using ICS8521I-03 LVHSTL buffer. Figure 3A shows a schematic example of the ICS8521I-03 LVHSTL Clock buffer. In this example,

the input is driven by an LVHSTL driver. CLK_EN is set at logic low to select CLK0/nCLK0 input.

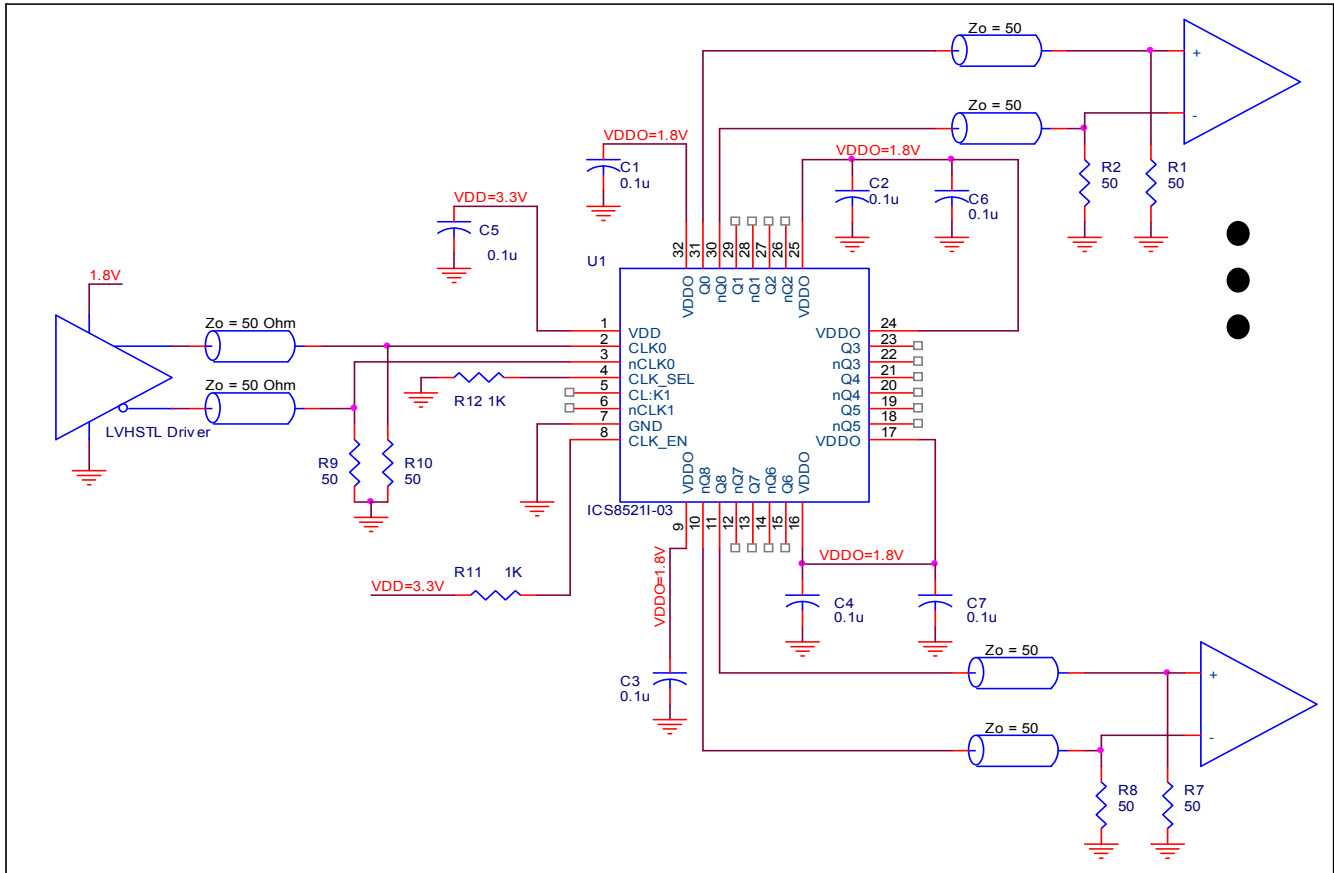

FIGURE 3A. ICS8521I-03 SCHEMATIC EXAMPLE

POWER, GROUND AND BYPASS CAPACITOR

This section provides a layout guide related to power, ground and placement of bypass capacitors for a high-speed digital IC. This layout guide is a general recommendation. The actual board design will depend on the component types being used, the board density and cost constraints. This description assumes that the board has clean power and ground planes. The goal is to minimize the ESR between the clean power/ground plane and the IC power/ground pin. A low ESR bypass capacitor should be used on each power pin. The value of bypass capacitors ranges from 0.01uF to 0.1uF. The bypass capacitors should be located

as close to the power pin as possible. It is preferable to locate the bypass capacitor on the same side as the IC. *Figure 3B* shows suggested capacitor placement. Placing the bypass capacitor on the same side as the IC allows the capacitor to have direct contact with the IC power pin. This can avoid any vias between the bypass capacitor and the IC power pins. The vias should be placed at the Power/Ground pads. There should be a minimum of one via per pin. Increasing the number of vias from the Power/Ground pads to Power/Ground planes can improve the conductivity

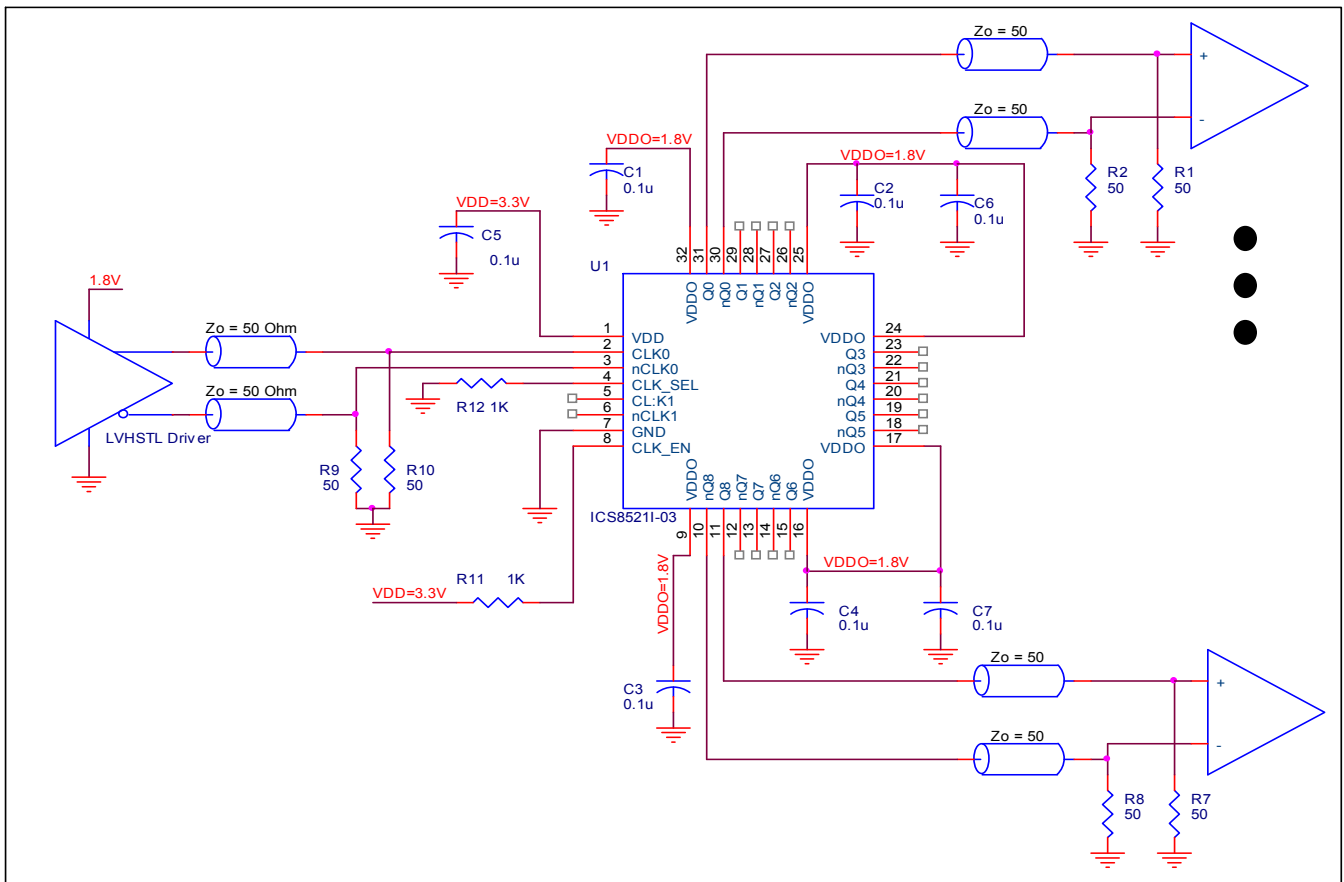

FIGURE 3B. RECOMMENDED LAYOUT OF BYPASS CAPACITOR PLACEMENT

DIFFERENTIAL CLOCK INPUT INTERFACE

The CLK/nCLK accepts LVDS, LVPECL, LVHSTL, SSTL, HCSTL and other differential signals. Both V_{SWING} and V_{OH} must meet the V_{PP} and V_{CMR} input requirements. Figures 4A to 4E show interface examples for the CLK/nCLK input driven by the most common driver types. The input interfaces suggested here

are examples only. Please consult with the vendor of the driver component to confirm the driver termination requirements. For example in *Figure 4A*, the input termination applies for LVHSTL drivers. If you are using an LVHSTL driver from another vendor, use their termination recommendation.

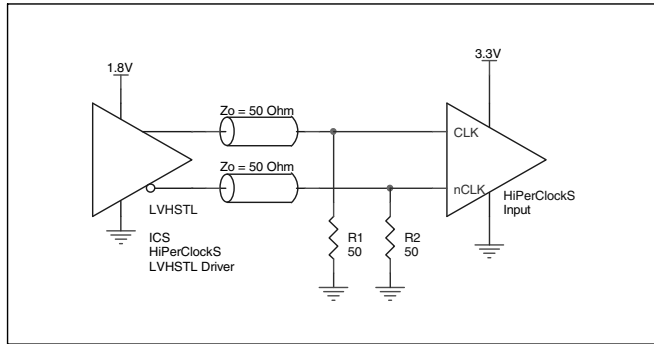

FIGURE 4A. CLK/nCLK INPUT DRIVEN BY LVHSTL DRIVER

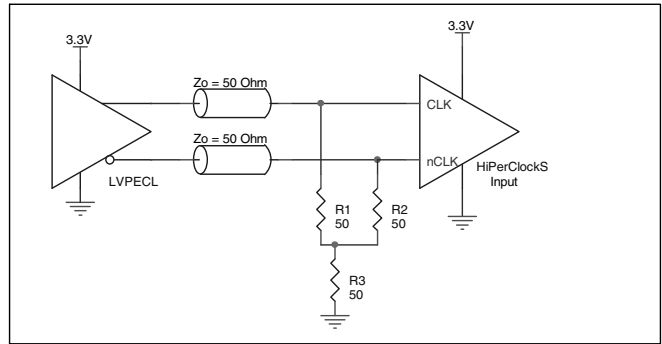

FIGURE 4B. CLK/nCLK INPUT DRIVEN BY 3.3V LVPECL DRIVER

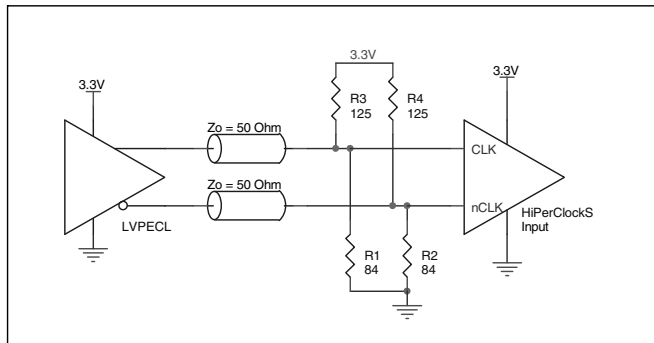

FIGURE 4C. CLK/nCLK INPUT DRIVEN BY 3.3V LVPECL DRIVER

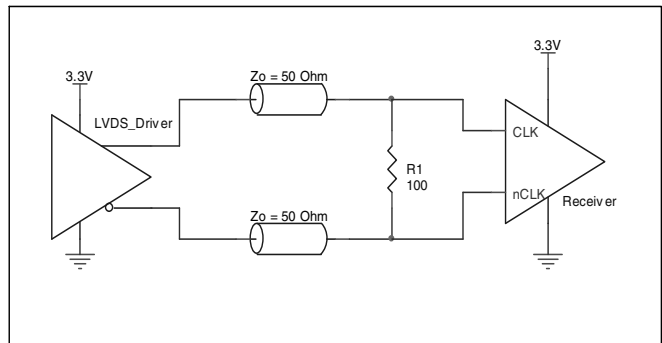

FIGURE 4D. CLK/nCLK INPUT DRIVEN BY 3.3V LVDS DRIVER

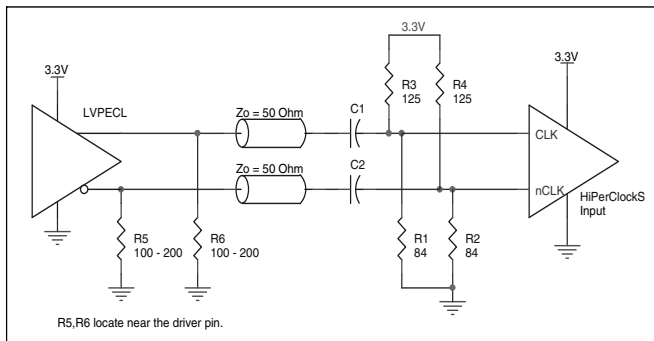

FIGURE 4E. CLK/nCLK INPUT DRIVEN BY 3.3V LVPECL DRIVER WITH AC COUPLE



POWER CONSIDERATIONS

This section provides information on power dissipation and junction temperature for the ICS8521I-03. Equations and example calculations are also provided.

1. Power Dissipation.

The total power dissipation for the ICS8521I-03 is the sum of the core power plus the power dissipated in the load(s). The following is the power dissipation for $V_{DD} = 3.3V + 5\% = 3.465V$, which gives worst case results.

NOTE: Please refer to Section 3 for details on calculating power dissipated in the load.

- Power (core)_{MAX} = $V_{DD_MAX} * I_{DD_MAX} = 3.465V * 95mA = 329.2mW$
- Power (outputs)_{MAX} = **32.8mW/Loaded Output pair**
 If all outputs are loaded, the total power is $9 * 32.8mW = 295.2mW$

Total Power_{MAX} (3.465V, with all outputs switching) = $329.2mW + 295.2mW = 624.4mW$

2. Junction Temperature.

Junction temperature, T_j, is the temperature at the junction of the bond wire and bond pad and directly affects the reliability of the device. The maximum recommended junction temperature for the devices is 125°C.

The equation for T_j is as follows: $T_j = \theta_{JA} * Pd_total + T_A$

T_j = Junction Temperature

θ_{JA} = junction-to-ambient thermal resistance

Pd_{total} = Total device power dissipation (example calculation is in section 1 above)

T_A = Ambient Temperature

In order to calculate junction temperature, the appropriate junction-to-ambient thermal resistance θ_{JA} must be used. Assuming a moderate air flow of 200 linear feet per minute and a multi-layer board, the appropriate value is 42.1°C/W per Table 6 below. Therefore, T_j for an ambient temperature of 85°C with all outputs switching is:

$85^\circ C + 0.624W * 42.1^\circ C/W = 111.3^\circ C$. This is well below the limit of 125°C.

This calculation is only an example. T_j will obviously vary depending on the number of loaded outputs, supply voltage, air flow, and the type of board (single layer or multi-layer).

TABLE 6. THERMAL RESISTANCE θ_{JA} FOR 32-PIN LQFP, FORCED CONVECTION

| θ_{JA} by Velocity (Linear Feet per Minute) | | | |
|--|----------|----------|----------|
| | 0 | 200 | 500 |
| Single-Layer PCB, JEDEC Standard Test Boards | 67.8°C/W | 55.9°C/W | 50.1°C/W |
| Multi-Layer PCB, JEDEC Standard Test Boards | 47.9°C/W | 42.1°C/W | 39.4°C/W |

NOTE: Most modern PCB designs use multi-layered boards. The data in the second row pertains to most designs.

3. Calculations and Equations.

The purpose of this section is to derive the power dissipated into the load.

LVHSTL output driver circuit and termination are shown in *Figure 5*.

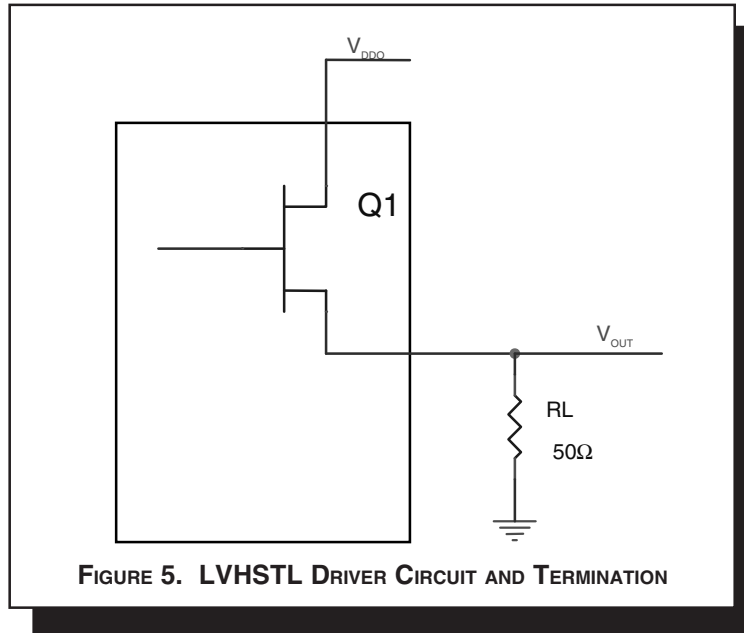

To calculate worst case power dissipation into the load, use the following equations which assume a 50Ω load.

Pd_H is power dissipation when the output drives high.
 Pd_L is the power dissipation when the output drives low.

$$Pd_H = (V_{OH_MAX} / R_L) * (V_{DDO_MAX} - V_{OH_MAX})$$

$$Pd_L = (V_{OL_MAX} / R_L) * (V_{DDO_MAX} - V_{OL_MAX})$$

$$Pd_H = (1.0V/50\Omega) * (2V - 1.0V) = \mathbf{20mW}$$

$$Pd_L = (0.4V/50\Omega) * (2V - 0.4V) = \mathbf{12.8mW}$$

Total Power Dissipation per output pair = Pd_H + Pd_L = **32.8mW**



RELIABILITY INFORMATION

TABLE 7. θ_{JA} VS. AIR FLOW TABLE

| θ_{JA} by Velocity (Linear Feet per Minute) | | | |
|--|----------|----------|----------|
| | 0 | 200 | 500 |
| Single-Layer PCB, JEDEC Standard Test Boards | 67.8°C/W | 55.9°C/W | 50.1°C/W |
| Multi-Layer PCB, JEDEC Standard Test Boards | 47.9°C/W | 42.1°C/W | 39.4°C/W |

NOTE: Most modern PCB designs use multi-layered boards. The data in the second row pertains to most designs.

TRANSISTOR COUNT

The transistor count for ICS8521I-03 is: 944

PACKAGE OUTLINE - Y SUFFIX

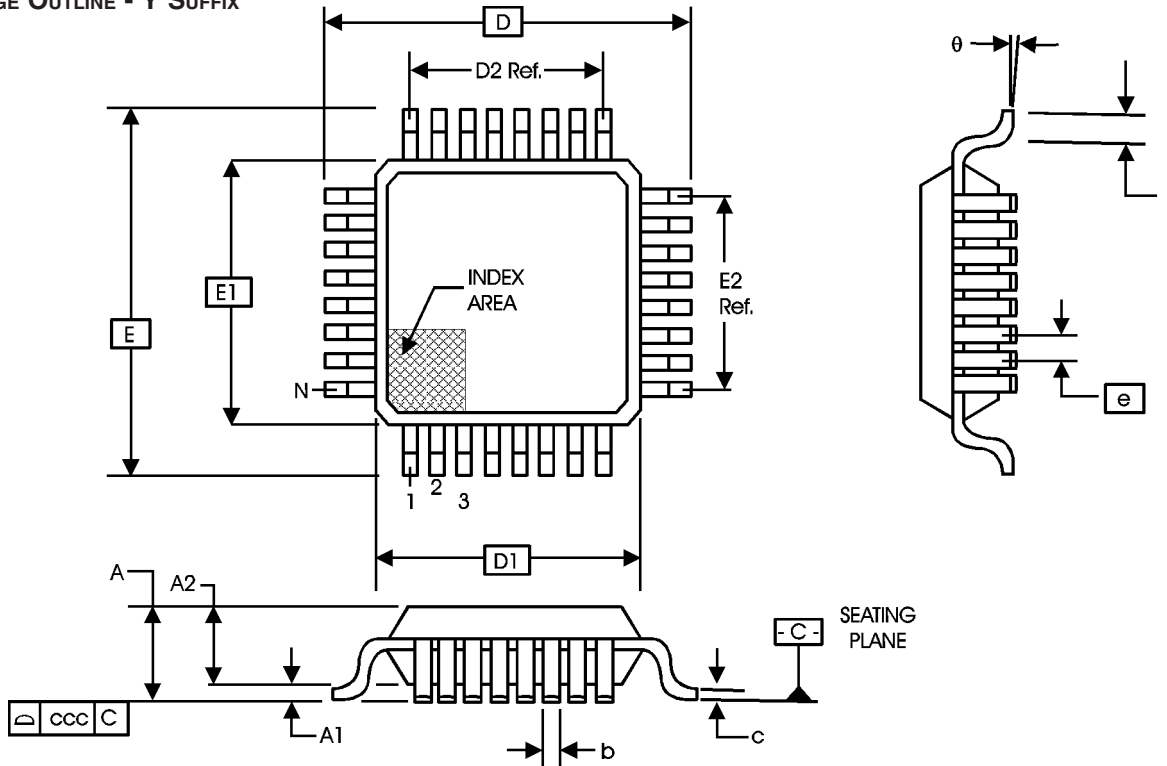

TABLE 8. PACKAGE DIMENSIONS

| JEDEC VARIATION ALL DIMENSIONS IN MILLIMETERS | | | |
|--|------------|---------|---------|
| SYMBOL | BBA | | |
| | MINIMUM | NOMINAL | MAXIMUM |
| N | 32 | | |
| A | -- | -- | 1.60 |
| A1 | 0.05 | -- | 0.15 |
| A2 | 1.35 | 1.40 | 1.45 |
| b | 0.30 | 0.37 | 0.45 |
| c | 0.09 | -- | 0.20 |
| D | 9.00 BASIC | | |
| D1 | 7.00 BASIC | | |
| D2 | 5.60 Ref. | | |
| E | 9.00 BASIC | | |
| E1 | 7.00 BASIC | | |
| E2 | 5.60 Ref. | | |
| e | 0.80 BASIC | | |
| L | 0.45 | 0.60 | 0.75 |
| theta | 0° | -- | 7° |
| ccc | -- | -- | 0.10 |

Reference Document: JEDEC Publication 95, MS-026



ICS8521I-03
LOW SKEW, 1-TO-9
DIFFERENTIAL-TO-LVHSTL FANOUT BUFFER

TABLE 9. ORDERING INFORMATION

| Part/Order Number | Marking | Package | Shipping Packaging | Temperature |
|-------------------|---------------|-------------------------------|--------------------|---------------|
| 8521AYI-03 | ICS8521AYI-03 | 32 Lead LQFP | tray | -40°C to 85°C |
| 8521AYI-03T | ICS8521AYI-03 | 32 Lead LQFP on Tape and Reel | 1000 | -40°C to 85°C |

While the information presented herein has been checked for both accuracy and reliability, Integrated Device Technology, Inc. (IDT) assumes no responsibility for either its use or for infringement of any patents or other rights of third parties, which would result from its use. No other circuits, patents, or licenses are implied. This product is intended for use in normal commercial and industrial applications. Any other applications such as those requiring high reliability, or other extraordinary environmental requirements are not recommended without additional processing by IDT. IDT reserves the right to change any circuitry or specifications without notice. IDT does not authorize or warrant any IDT product for use in life support devices or critical medical instruments.



| REVISION HISTORY SHEET | | | | |
|------------------------|-------|----------|--|---------|
| Rev | Table | Page | Description of Change | Date |
| B | T9 | 15 17 | Updated datasheet's header/footer with IDT from ICS. Removed ICS prefix from Part/Order Number column. Added Contact Page. | 7/26/10 |
| | | | | |
| | | | | |



ICS8521I-03
LOW SKEW, 1-TO-9
DIFFERENTIAL-TO-LVHSTL FANOUT BUFFER

We've Got Your Timing Solution.



6024 Silver Creek Valley Road
San Jose, CA 95138

Sales
800-345-7015 (inside USA)
+408-284-8200 (outside USA)
Fax: 408-284-2775

Tech Support
netcom@idt.com

© 2010 Integrated Device Technology, Inc. All rights reserved. Product specifications subject to change without notice. IDT, the IDT logo, ICS and HiPerClockS are trademarks of Integrated Device Technology, Inc. Accelerated Thinking is a service mark of Integrated Device Technology, Inc. All other brands, product names and marks are or may be trademarks or registered trademarks used to identify products or services of their respective owners.
Printed in USA