

Recording Equalizer Amplifier for Stereo Cassette Decks

Description

The CXA1579P/M is a bipolar IC developed for recording equalizer in analog cassette decks. It is suited specifically for double cassette decks. Built-in filter circuit greatly reduces the external parts

Features

- Built-in the filter required for recording equalizers
- Inductor (coil) is unnecessary
- Low frequency boost is possible with an external capacitor
- Built-in recording mute function (requiring only an external time constant circuit to implement soft mute)
- Fade in/out DC controllable
- NORM/CrO₂/METAL tape mode switching function
- NORM/HIGH speed recording switching function
- DC controllable for recording level fine adjustment (calibration) (approximately ± 5dB variable)
- DC controllable for high frequency equalizer gain (approximately ± 4dB variable)
- Built-in 2 channels
- Small package (16 pin DIP)

Applications

Recording equalizer amplifier for stereo analog cassette decks (Compatible with ALPS ELECTRIC CO., LTD. HAYEH44-series heads)

Block Diagram and Pin Configuration (Top View)

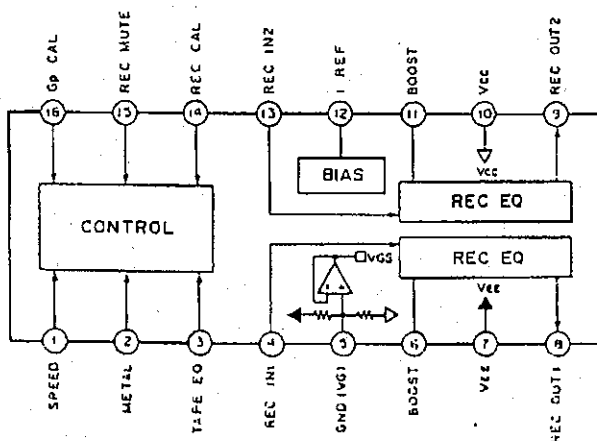

Sony reserves the right to change products and specifications without prior notice. This information does not convey any license by any implication or otherwise under any patents or other right. Application circuits shown, if any, are typical examples illustrating the operation of the devices. Sony cannot assume responsibility for any problems arising out of the use of these circuits.

CXA1579P
16 pin DIP (Plastic)

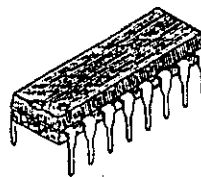

CXA1579M
16 pin SOP (Plastic)



Functions

- Recording equalizer (Low frequency boost is possible with an external capacitor)
- Recording mute (DC controllable for soft mute and fade in/out)
- Mode switching (NORM/CrO₂/METAL tape and NORM/HIGH speed 6-mode switching)
- Recording calibration (DC controllable for recording level fine adjustment)
- High frequency calibration (DC controllable for high frequency equalizer gain)

Structure

Bipolar silicon monolithic IC

Absolute Maximum Ratings (Ta=25 °C)

- Supply voltage Vcc 17 V
- Operating temperature Topr -20 to +75 °C
- Storage temperature Tstg -65 to +150 °C
- Allowable power dissipation Pd .930 mW

Supply Voltage Range

- Supply voltage Vcc, VEE ± 4.5 to ± 8.0 V (positive/negative dual power supplies)
Vcc 9.0 to 16.0 V (single power supply)
- Operating temperature Topr -20 to +75 °C

Pin Description and Equivalent Circuit

(Ta=25°C, VCC=+7.5V, VEE=-7.5V, no signal)

Pin No.	Symbol	DC voltage	I/O	Zin	Equivalent circuit	Description
1	SPEED	—	I	—		Tape speed switching pin. (NORMAL/HIGH speed) High → HIGH speed Low → NORMAL speed
2	METAL	—	I	—		Metal tape switching pin. (METAL/METAL) High → METAL tape Low → NORM or CrO ₂ tape
3	Tape EQ	—	I	—		Tape equalizer switching pin. (120 μs/70 μs EQ) High → 70 μs EQ (CrO ₂) Low → 120 μs EQ (NORM)
4 13	REC IN1 REC IN2	0.0V	I	50kΩ		Recording equalizer amplifier input pin.
5	GND (VG)	0.0V	I	15kΩ		Connect to GND for positive/negative dual power supplies. Vcc divided by 2 for a single power supply. (Connect a capacitor of 10 μF or more)
6 11	BOOST1 BOOST2	0.0V	I	9.5kΩ		Connection pin of an external capacitor for low frequency boost. * When low frequency boost is unnecessary, connect to GND for positive/negative dual power supplies. Connect a capacitor (3.3 μF or more) for a single power supply.

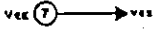
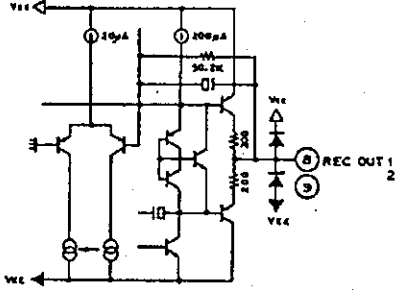
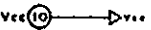
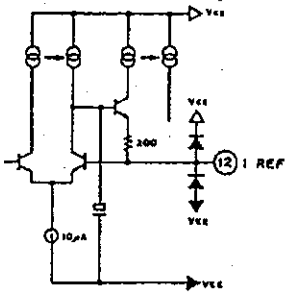
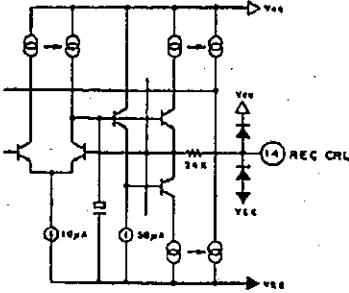
Pin No.	Symbol	DC voltage	I/O	Zin	Equivalent circuit	Description
7	V _{EE}	-7.5V	—	—		Connect to the negative power supply for positive/negative dual power supplies. Connect to GND for a single power supply.
8 9	REC OUT1 REC OUT2	0.0V	O	—		Recording equalizer amplifier output pin.
10	V _{CC}	7.5V	—	—		Positive power supply pin.
12	I _{REF}	-6.3V	O	—		Reference current setting pin for monolithic filter.
14	REC CAL	2.5V	I	54kΩ		Recording calibration (recording level fine adjustment) pin. * Controlled with DC voltages of 0 to 5V. High=Recording level gain reduced Low=Recording level gain increased * Leave this pin open when not using the recording calibration function.

Pin No.	Symbol	DC voltage	I/O	Zin	Equivalent circuit	Description
15	REC MUTE	5.0V	I	—		<p>Recording mute ON/OFF selection pin.</p> <ul style="list-style-type: none"> * Recording mute is controlled with DC voltages of 0 to 5V. High=Recording mute OFF Low=Recording mute ON * Soft mute and fader can be switched over by changing the time constant of the external time constant circuit.
16	Gp CAL	2.5V	I	54kΩ		<p>High frequency calibration (recording level fine adjustment in high frequencies) pin.</p> <ul style="list-style-type: none"> * Controlled with DC voltages of 0 to 5V High=High frequency level gain reduced Low=High frequency level gain increased * Leave this pin open when not using the high-frequency calibration function.

Electrical Characteristics

(Ta=25°C, Vcc=+7.5V, VEE=-7.5V)

Item	Symbol	Measurement conditions *	Min.	Typ.	Max.	Unit	
Operating voltage	Vopr	Positive/negative dual power supplies	± 4.5	—	± 8.0	V	
		Single power supply	9.0	—	16.0	V	
Current consumption	Icc	NORM-NORM, no signal	8.4	12.5	18.0	mA	
Reference input level	VIN	NORM-NORM, 315Hz	- 21.5	- 20.0	- 18.5	dBm	
Reference output level	VOUT	NORM-NORM, 315Hz	—	- 5.0	—	dBm	
S/N ratio (NORM-NORM)	SN (A-WTG)	Rg=5kΩ, "A"-WTG filter	55.0	58.2	—	dB	
Signal handling	SH	RL=2.7kΩ, 1kHz, THD=1%	15.0	18.0	—	dB	
Total higher harmonic distortion	THD	RL=2.7kΩ, 1kHz, 0dB	—	0.23	0.5	%	
Output offset voltage	VOFF	NORM-NORM	- 0.5	0.0	0.5	V	
NORM-NORM mode frequency characteristics 0dB=315Hz, -20dB	FNN-1	3kHz, -20dB	For NORM-NORM at 315Hz, -20dB	- 1.9	- 0.9	0.6	dB
	FNN-2	8kHz, -20dB		2.2	4.2	6.2	dB
	FNN-3	12kHz, -20dB		6.7	10.2	13.7	dB
CrO2-NORM mode frequency characteristics	FCN-1	3kHz, -20dB	For NORM-NORM at 315Hz, -20dB	3.7	4.7	6.2	dB
	FCN-2	8kHz, -20dB		8.1	10.1	12.1	dB
	FCN-3	12kHz, -20dB		12.3	15.8	19.3	dB
METAL-NORM mode frequency characteristics	FMN-1	3kHz, -20dB	For NORM-NORM at 315Hz, -20dB	3.6	4.6	6.1	dB
	FMN-2	8kHz, -20dB		6.7	8.2	9.7	dB
	FMN-3	12kHz, -20dB		9.3	12.3	15.3	dB
NORM-HIGH mode frequency characteristics	FNH-1	5kHz, -20dB	For NORM-NORM at 315Hz, -20dB	- 4.6	- 3.6	- 2.1	dB
	FNH-2	15kHz, -20dB		- 0.7	1.3	3.3	dB
	FNH-3	20kHz, -20dB		2.4	5.4	8.4	dB
CrO2-HIGH mode frequency characteristics	FCH-1	5kHz, -20dB	For NORM-NORM at 315Hz, -20dB	1.2	2.2	3.7	dB
	FCH-2	15kHz, -20dB		5.6	7.6	9.6	dB
	FCH-3	20kHz, -20dB		8.6	11.6	14.6	dB
METAL-HIGH mode frequency characteristics	FMH-1	5kHz, -20dB	For NORM-NORM at 315Hz, -20dB	- 2.7	- 1.7	- 0.7	dB
	FMH-2	15kHz, -20dB		- 1.7	- 0.2	1.3	dB
	FMH-3	20kHz, -20dB		0.1	2.1	4.1	dB
Recording mute	MT-1	NORM-NORM, 1kHz, +15dB	—	- 95.0	- 80.0	dB	
Recording mute characteristics	MT-2	NORM-NORM, 1kHz, 2.5V (pin voltage)	- 7.5	- 6.0	- 4.5	dB	
REC CAL characteristics 0dB=315Hz, -20dB	R-CAL1	NORM-NORM, 315Hz, 0V (pin voltage)	5.1	6.1	8.1	dB	
	R-CAL2	NORM-NORM, 315Hz, 5V (pin voltage)	- 8.9	- 6.9	- 4.9	dB	
Gp CAL characteristics 0dB=8kHz, -20dB	G-CAL1	NORM-NORM, 8kHz, 0V (pin voltage)	3.9	5.9	7.9	dB	
	G-CAL2	NORM-NORM, 8kHz, 5V (pin voltage)	- 5.9	- 3.9	- 1.9	dB	
Control voltage high level	VCH	Threshold voltage for mode control pin	3.0	—	Vcc	V	
Control voltage low level	VCL	Threshold voltage for mode control pin	GND	—	1.0	V	

* NORM-NORM=NORMAL Tape, NORMAL Speed
 CrO2-NORM=CrO2 Tape, NORMAL Speed
 METAL-NORM=METAL Tape, NORMAL Speed

NORM-HIGH=NORMAL Tape, HIGH Speed
 CrO2-HIGH=CrO2 Tape, HIGH Speed
 METAL-HIGH=METAL Tape, HIGH Speed

Electrical Characteristic Test Circuit Diagram

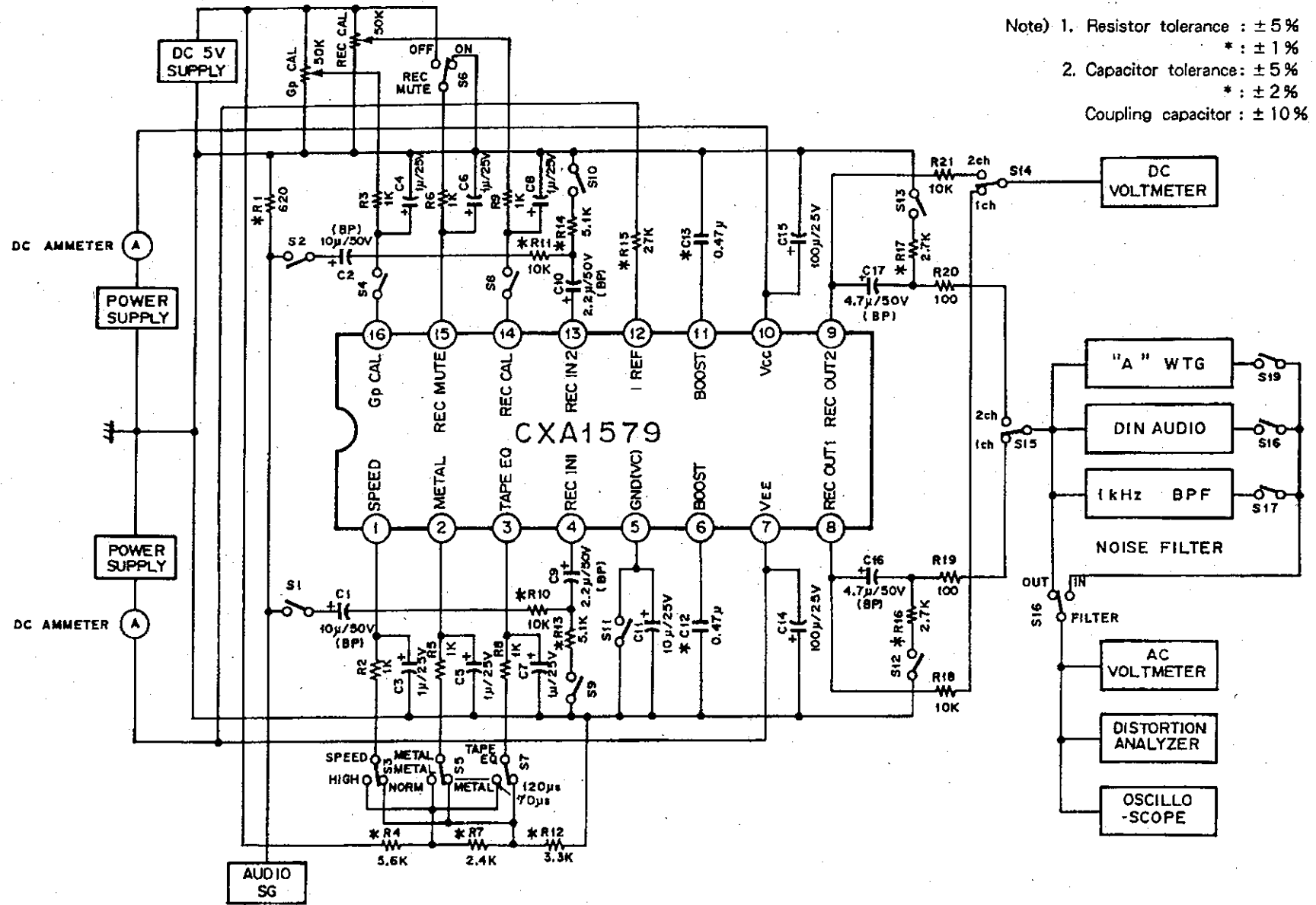

Note) 1. Resistor tolerance : $\pm 5\%$
 * : $\pm 1\%$
 2. Capacitor tolerance: $\pm 5\%$
 * : $\pm 2\%$
 Coupling capacitor : $\pm 10\%$

Description of Operation

1. Recording equalizer amplifier

The primary features of the CX1579 recording equalizer amplifier is that by taking full advantage of monolithic filter technology, an LC resonance circuit consisting of a coil and capacitor normally required for high frequency compensation is dispensed with and medium and low-frequency sensitivity compensation is performed with its internal filter alone.

The CX1579 has the circuit configuration shown in Fig. 1 to provide the optimum frequency characteristics required for recording equalizers.

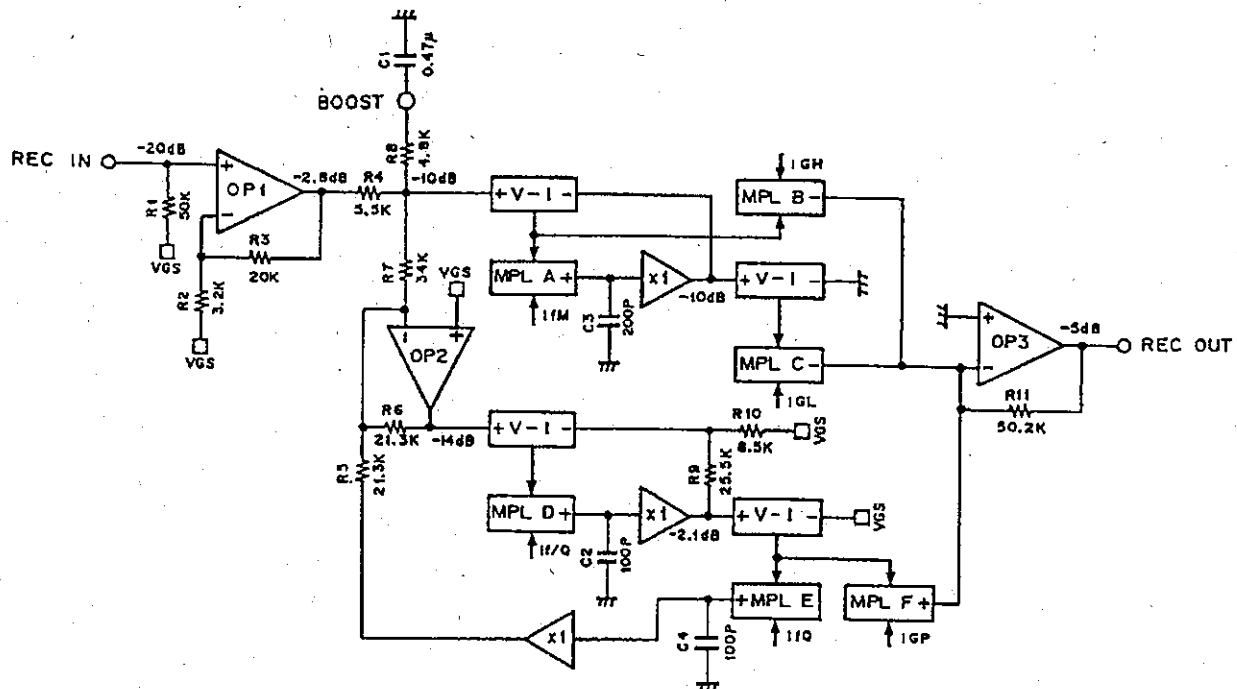

Fig. 1. CX1579 functional circuit block diagram

The symbol (V-I) shown in Fig. 1 denotes a "voltage \rightarrow current converter circuit," and (MPL) means a "multiplier circuit."

The "voltage \rightarrow current converter circuit" (V-I) converts the voltage between the positive and negative input pins into current by using the IC's internal diffused resistance. The "multiplier circuit" (MPL) multiplies the current generated by the "voltage \rightarrow current converter circuit" with a coefficient.

The recording equalizer requires the six parameters shown in Fig. 2 (G_L , G_H , G_P , f_M , f_P , and Q) to implement its frequency characteristics. These parameters are controlled by each control current shown in Fig. 1 (I_{GL} , I_{GH} , I_{GP} , I_{fM} , $I_{f/Q}$, and I_{fQ}).

Therefore, the CX1579 reduces fluctuations caused by the temperature characteristics and unevenness of its internal diffused resistance by using currents which are independent of the internal diffused resistance (currents which depend on external resistance) and those which are dependent on the internal diffused resistance.

The CX1579 uses currents dependent on the diffused resistance where equalizer gain is determined and currents dependent on external resistance where the filter time constant is determined. This is because the generatrix of the coefficient for the "multiplier circuit" is generated in the IC so that it depends on the diffused resistance. Consequently, the gain relationship of G_L , G_H , and G_P is such that because the current obtained by the "voltage \rightarrow current converter circuit" is converted into voltage by the I-V amplifier in the final stage of Fig. 1, the control currents are controlled by currents dependent on the diffused current. In this way, the coefficients for conversion [voltage \rightarrow current \rightarrow voltage] all becomes ratios to the diffused resistance, so that the fluctuations of temperature characteristic and unevenness are reduced.

Also, the relationship of time constants f_m , f_p , and Q is configured by the product of the current obtained with the "voltage → current converter circuit" and the IC's internal capacitance connected to the output of each "multiplier circuit". By using the currents determined by the CXA1579 external resistance not dependent on the diffused resistance for control, the coefficients for voltage → current conversion become certain ratios to the diffused resistance; therefore, the frequency characteristics do not depend on the diffused resistance.

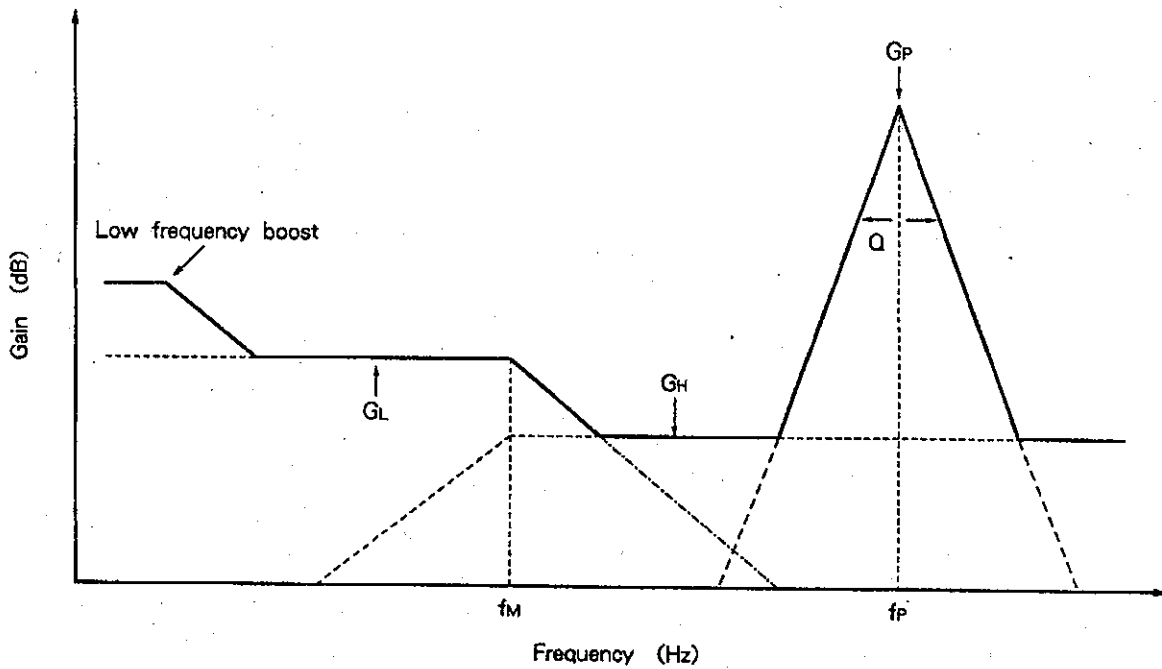

Fig. 2. Conceptual diagram of CXA1579 frequency characteristics

2. Low frequency boost

The CXA1579 implements low frequency boost simply by attaching an external capacitor. As shown in Fig.1, this IC contains a resistance-based attenuation circuit after the input amplifier, with one of the resistors connected to the BOOST pins (Pins 6 and 11). When a capacitor is connected to these BOOST pins (Pins 6 and 11), the following transfer function is obtained:

$$G_{BOOST}(s) = \frac{s \cdot C_1 \cdot R_7 \cdot R_8 + R_7}{s \cdot C_1 \cdot (R_4 \cdot R_7 + R_7 \cdot R_8 + R_8 \cdot R_4) + (R_4 + R_7)} \quad (s = j\omega)$$

From the above, items f_1 , f_2 , A_1 , and A_2 in Fig. 3 are transformed into the following:

$$f_1 = \frac{R_4 + R_7}{2 \pi \cdot C_1 \cdot (R_4 \cdot R_7 + R_7 \cdot R_8 + R_8 \cdot R_4)} = \frac{1}{2 \pi \cdot C_1 \cdot \left(\frac{R_4 \cdot R_7}{R_4 + R_7} + R_8 \right)}$$

$$f_2 = \frac{1}{2 \pi \cdot C_1 \cdot R_8}$$

$$A_1 = \frac{R_7}{R_4 + R_7}$$

$$A_2 = \frac{R_7 \cdot R_8}{R_4 \cdot R_7 + R_7 \cdot R_8 + R_8 \cdot R_4} = \frac{\frac{R_7 \cdot R_8}{R_7 + R_8}}{R_4 + \frac{R_7 \cdot R_8}{R_7 + R_8}}$$

Here, $R_4=5.5k\Omega$, $R_7=34k\Omega$, and $R_8=4.8k\Omega$. Therefore, A_1 and A_2 take on the following values:

$A_1=0.861$ (times) $=-1.30$ (dB); $A_2=0.433$ (times) $=-7.26$ (dB)

The difference between A_1 and A_2 is approximately 6dB, so that 6dB boost can be applied for low frequency boost. The boost frequency characteristics can be freely set with the value of the external C_1 capacitor.

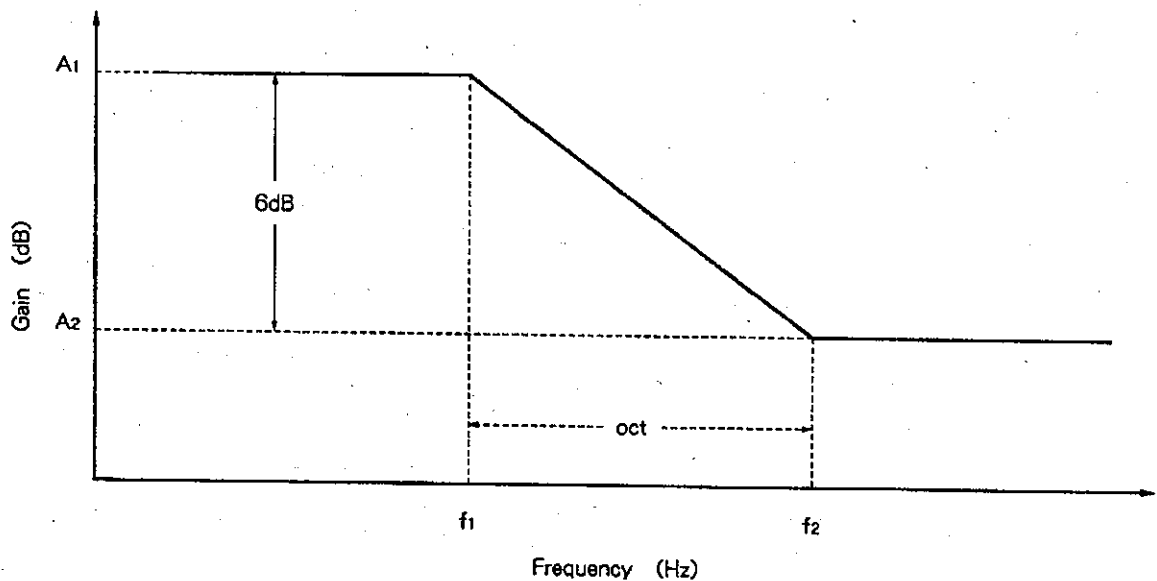

Fig. 3. CXA1579 low frequency boost frequency characteristics

3. Recording mute function

The CXA1579 recording mute function is implemented by using built-in recording mute circuit which varies the recording equalizer amplifier gain according to the magnitude of the DC voltage applied to the REC MUTE pin (Pin 15) just like an electronic volume control. For this reason, any desired soft mute (gradual signal attenuation without distortion) or fader (fade in/out) can be freely set depending on momentary changes in the DC voltage applied to the REC MUTE pin (Pin 15).

The CXA1579 recording mute circuit operation is such that the reference voltage source used to generate the control currents (IGL, IGH, and IGP) to control each gain (G_L , G_H , and G_P) shown in Fig. 1 is varied by the voltage input to the REC MUTE pin (Pin 15), so that the recording signal is attenuated while maintaining the respective gain ratios. Eventually, when the recording signal is completely muted, only the I-V amplifier in the final stage is connected to the output pin (REC OUT). Therefore, the noise of the monolithic filter consisting of each "voltage \rightarrow current converter circuit" and "multiplier circuit" is attenuated simultaneously with the recording signal. At this point in time, the I-V amplifier in the final stage is functioning almost as a buffer, providing a significant amount of mute. Fig. 4 illustrates the recording mute waveforms.

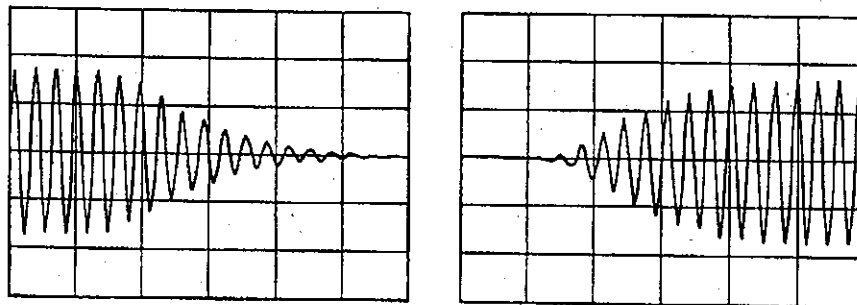

Fig. 4. Recording mute waveform

4. Recording level fine adjustment (calibration) function

The CXA1579 allows the recording level to be fine adjusted with DC voltage. The recording equalizer amplifier gain can be varied approximately $\pm 5\text{dB}$ simply by applying DC voltage to the REC CAL pin (Pin 14). Circuit operation for this is such that each gain (G_L , G_H , and G_P) is varied relative to the reference voltage source which controls currents (I_{GL} , I_{GH} , and I_{GP}) by varying its voltage as in the case of the recording mute circuit.

The input resistance of the REC CAL pin (Pin 14) is $54\text{k}\Omega$ as described in the section of Pin Description, which is equivalent to the CXA1579 internal diffused resistance. This means the voltage converted into current by the diffused resistance is the difference between the DC voltage applied to the REC CAL pin (Pin 14) and the internal reference voltage (2.5V), so that all coefficients become ratios to the diffused resistance as described in the section of 'Recording equalizer amplifier'. Recording level can be fine adjusted independent of the temperature characteristics and unevenness inherent in the IC.

This recording level fine adjustment performs in all modes (NORM/CrO₂/METAL tape, NORM/HIGH speeds, as well as the recording mute mode).

When not using the recording level fine adjustment function, simply leave the REC CAL pin (Pin 14) open, and the voltage at the REC CAL pin (Pin 14) is matched to the internal reference voltage (2.5V), with the recording level set for the standard output gain.

5. High-frequency equalizer fine adjustment (calibration) function

In addition to the recording level fine adjustment function, the CXA1579 permits high frequency equalizer characteristics to be controlled with DC voltage. By simply applying DC voltage to the GP CAL pin (Pin 16) as in the case of the recording level fine adjustment function, the recording equalizer amplifier gain (only the GP gain) can be varied approximately ± 4 dB. This function also varies relatively GP gain when the recording level fine adjustment function is activated. Circuit operation for this function is such that the voltage applied to the pin is converted into current by the internal IC diffused resistance as in the case of recording level fine adjustment, and that the "multiplier circuit" provides a coefficient to the control current according to the value of the GP gain control current (IGP) for the mode currently set.

Therefore, fine adjustment of high frequency equalizer characteristics independent of the temperature characteristics and unevenness inherent in the IC, as in the case of recording level fine adjustment. This function, too, operates in all modes.

When not using the high frequency equalizer fine adjustment function, simply leave the GP CAL pin (Pin 16) open, and the high frequency equalizer characteristics are set for standard output gain.

Fig. 5 schematically shows the function of recording level/high frequency equalizer fine adjustment.

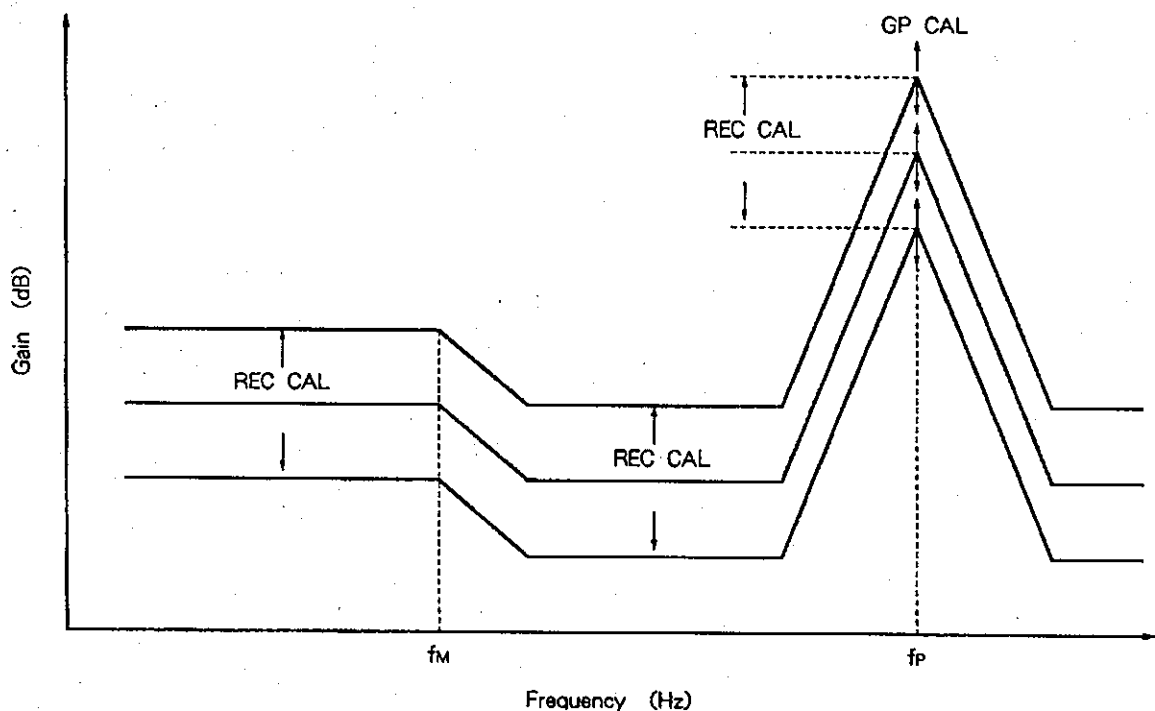

Fig. 5. Conceptual diagram of recording level/high frequency equalizer fine adjustment functions

The noise level of recording equalizer amplifier is relatively changed by varying the CXA1579 recording level/high frequency equalizer.

6. Temperature characteristics and accuracy of the recording equalizer amplifier

The temperature characteristics of built-in monolithic filter and the filter cut-off frequency depend on the $27k\Omega$ external resistance connected to the I REF pin (Pin 12). For low frequency boost, however, the cut-off frequency becomes uneven depending on the temperature characteristic or unevenness of the internal IC diffused resistance since its time constant is configured by the product of an external capacitor and the internal IC diffused resistance.

Also, the recording equalizer frequency characteristics depend on unevenness in the absolute, as well as relative values of the internal IC capacitance. Furthermore, the high frequency characteristics indicate a high element sensitivity at the filter because the band-pass filter Q is high. Compared to low frequency, the unevenness inherent in IC more likely occurs but that does relatively, and not individually for channels 1 and 2.

Notes on Operation

1. Power supply

The CXA1579 is designed basically for positive/negative dual power supplies, and can also operate with a single power supply. Connect the power supplies for each case as shown below:

	V _{CC} (Pin 10)	V _{EE} (Pin 7)	GND (Pin 5)
Positive/negative dual power supplies	Positive power supply	Negative power supply	GND
Single power supply	Power supply	GND	— *1

*1: For a single power supply, connect a decoupling capacitor (10 μ F or more) to the GND (VG) pin (Pin 5).
The ripple rejection ratio and channel cross talk depend on the capacitance of this capacitor.

For connecting a low frequency boost capacitor, designated control voltage for each control pin, and other details for each power supply configuration, refer to the related explanation in the following pages of this data sheet.

2. Operation mode control (NORM/CrO₂/METAL tape and NORM/HIGH speed six modes)

The CXA1579 incorporates an electronic switch circuit and its operation is controlled by the DC voltage applied to the three mode control pins – TAPE EQ pin (Pin 3), METAL pin (Pin 2), and SPEED pin (Pin 1).

The threshold regulations (V_{CH} and V_{CL}) of each mode control are as follows:

- a) For positive/negative dual power supplies

$$3.0V \leq V_{CH} \leq V_{CC}$$

$$GND \leq V_{CL} \leq 1.0V$$

- b) For single power supply

$$V_{CC}/2+3.0V \leq V_{CH} \leq V_{CC}$$

$$GND \leq V_{CL} \leq V_{CC}/2+1.0V$$

*2: Referenced to the GND pin (Pin 5).

The table below shows the operation mode status in each mode control.

TAPE EQ \ METAL	(METAL) L	(METAL) H
(TAPE EQ) L	NORMAL (Type- I)	METAL (Type- IV)
(TAPE EQ) H	CrO ₂ (Type- II)	METAL (Type- IV)

SPEED	L	H
Recording speed	NORMAL Speed	HIGH Speed

If the switching click noise presents a problem, add time constant circuits of 100ms to 1s to the mode control pins. Since the mode control circuit has a linear region of approximately ± 300 mV, this time constant circuit may effectively reduce the switching click noise.

3. Recording mute function (soft mute, fade in/out)

As described in Description of Operation, the CXA1579 recording mute function is implemented by using a built-in recording mute circuit which varies the recording equalizer amplifier gain according to the magnitude of the DC voltage applied to the REC MUTE pin (Pin 15) just like an electronic volume control. Consequently, the muting time can be varied according to changes in time of the DC voltage applied to the REC MUTE pin (Pin15) and, furthermore, the recording signal can be gradually attenuated without causing distortion. The table below shows the relationship between the DC voltage applied to the REC MUTE pin (Pin 15) and the attenuation. (Note that the regulation range varies with the power supplies used.)*³

Control voltage	Recording mute ON	Attenuation -6dB	Recording mute OFF
Positive/negative dual power supplies	$V_{EE}+2.0V$ to $0.35V$	2.5V	4.5V to V_{CC}
Single power supply	2.0V to $V_{CC}/2+0.35V$	$V_{CC}/2+2.5V$	$V_{CC}/2+4.5V$ to V_{CC}

*3: Referenced to the GND pin (Pin 5).

4. Low frequency boost (low frequency compensation)

The CXA1579 low frequency boost function can be implemented simply by connecting a capacitor to the BOOST pin (Pins 6 and 11) as described in Description of Operation. Although the boost is fixed to 6dB, the time constant which determines the cut-off frequency can be set to any desired value depending on the capacitance of the external capacitor. The pole (f_1) and zero (f_2) shown in Fig. 3. Low frequency boost frequency characteristics can be expressed, with the external capacitor assumed to be C_B , as follows:

$$f_1 = \frac{1}{2\pi \cdot C_B \cdot (9.53k\Omega)} \text{ (Hz)}, \quad f_2 = \frac{1}{2\pi \cdot C_B \cdot (4.8k\Omega)} \text{ (Hz)}$$

Based on the above equation, determine the best low frequency characteristics.

However, the resistance which determines the time constant along with the external capacitor is the CXA1579 internal diffused resistance, so that the time constant tends to fluctuate depending on the unevenness inherent in the IC and temperature characteristics. Note that the unevenness and the temperature characteristics of the diffused resistance that determines the low frequency boost frequency characteristics are approximately $\pm 20\%$ and $+2500\text{ppm}/^\circ\text{C}$, respectively.

When not using low frequency boost, follow the procedure described below:

a) For positive/negative dual power supplies

Connect the BOOST pin (Pins 6 and 11) to GND.

b) For single power supply

Connect a fairly large capacitor ($3.3 \mu\text{F}$ or more) to the BOOST pin (Pins 6 and 11) or simply leave the BOOST pins open. If the BOOST pins are left open, note that the output level increases by 6dB, so the input reference should be set 6dB down. The CXA1579 is basically designed for positive/negative dual power supplies and the BOOST pins cannot be easily connected to GND as in the case of positive/negative dual power supplies.

5. Recording calibration (recording level fine adjustment)

The CXA1579 allows the recording level to be fine adjusted by DC voltage as described in Description of Operation. Therefore, the recording level can be varied approximately $\pm 5\text{dB}$ simply by applying DC voltages of 0 to 5V (for positive/negative dual power supplies) to the REC CAL pin (Pin 14). Note, however, that the DC voltage to be applied for control varies with the power supply used.

The table below shows the input range regulation of control voltages with the power supplies used. *4

Power supply used	Recording level	Up	Typ.	Down
Positive/negative dual power supplies		V_{EE} to 2.5V	2.5V	2.5V to V_{CC}
Single power supply		GND to $V_{CC}/2+2.5\text{V}$	$V_{CC}/2+2.5\text{V}$	$V_{CC}/2+2.5\text{V}$ to V_{CC}

*4: Although the above range of voltages can be input to the control pin, the controllable input voltage range is as follows:

- a) For positive/negative dual power supplies

$$2.5\text{V} < V_{\text{DOWN}} \leq 5.0\text{V}$$

$$\text{GND} \leq V_{\text{UP}} < 2.5\text{V}$$

- b) For single power supply *5

$$V_{CC}/2+2.5\text{V} < V_{\text{DOWN}} \leq V_{CC}/2+5.0\text{V}$$

$$V_{CC}/2 \leq V_{\text{UP}} < V_{CC}/2+2.5\text{V}$$

*5: This IC is basically designed for positive/negative dual power supplies, so that the control voltages are referenced to the GND pin (Pin 5).

Also note that when not using this recording calibration function, simply leave the REC CAL pin (Pin 14) open, so that the voltage on the REC CAL pin will be matched to the internal reference voltage (2.5V), with the recording level set for the standard gain.

6. High frequency calibration (high frequency equalizer characteristics fine adjustment)

The CXA1579 allows the high frequency recording equalizer characteristics to be controlled by DC voltage as described in Description of Operation. Therefore, the peaking gain in high frequencies can be varied approximately $\pm 4\text{dB}$ simply by applying DC voltages of 0 to 5V (for positive/negative dual power supplies) to the G_P CAL pin (Pin 16). Note, however, that the DC voltage to be applied for control varies with the power supplies used.

The table below shows the input range regulation of control voltages with the power supplies used. *6

Power supply used \ Recording level	Up	Typ.	Down
Positive/negative dual power supplies	V_{EE} to 2.5V	2.5V	2.5V to V_{CC}
Single power supply	GND to $V_{CC}/2+2.5V$	$V_{CC}/2+2.5V$	$V_{CC}/2+2.5V$ to V_{CC}

*6: Although the above range of voltages can be input to the control pin, the controllable input voltage range is as follows:

- a) For positive/negative dual power supplies
 $2.5V < V_{DOWN} \leq 5.0V$
 $GND \leq V_{UP} < 2.5V$

- b) For single power supply *7
 $V_{CC}/2+2.5V < V_{DOWN} \leq V_{CC}/2+5.0V$
 $V_{CC}/2 \leq V_{UP} < V_{CC}/2+2.5V$

*7: This IC is basically designed for positive/negative dual power supplies, the control voltages are referenced to the GND-pin (Pin 5).

Also note that when not using this high frequency calibration function, simply leave the G_P CAL pin (Pin 16) open, so that the voltage at the G_P CAL pin will be matched to the internal reference voltage (2.5V), with the high frequency equalizer characteristics set for the standard G_P gain.

7. Monolithic filter reference resistance (the resistance connected to the I REF pin)

To increase the accuracy of frequency characteristics of its internal monolithic filter, the CXA1579 entrusts the control current that determines the filter time constant to an external resistance. Specifically, this resistance is the $27\text{k}\Omega$ external resistor connected to the I REF pin (Pin 12). This means that the accuracy of the recording equalizer amplifier frequency characteristics are determined by the resistance connected to the I REF pin. Therefore, the resistor used for this purpose must be free of unevenness and have excellent temperature characteristics (e.g., a metallic film resistor).

Also note that the recording equalizer amplifier frequency characteristics can be shifted as desired by altering the value of the resistance connected to the I REF pin. For example, when the resistance value is reduced, the frequency characteristics are shifted to high-frequency side and when that is increased, the frequency characteristics are shifted to low-frequency side

Application Circuit (For positive/negative dual power supplies)

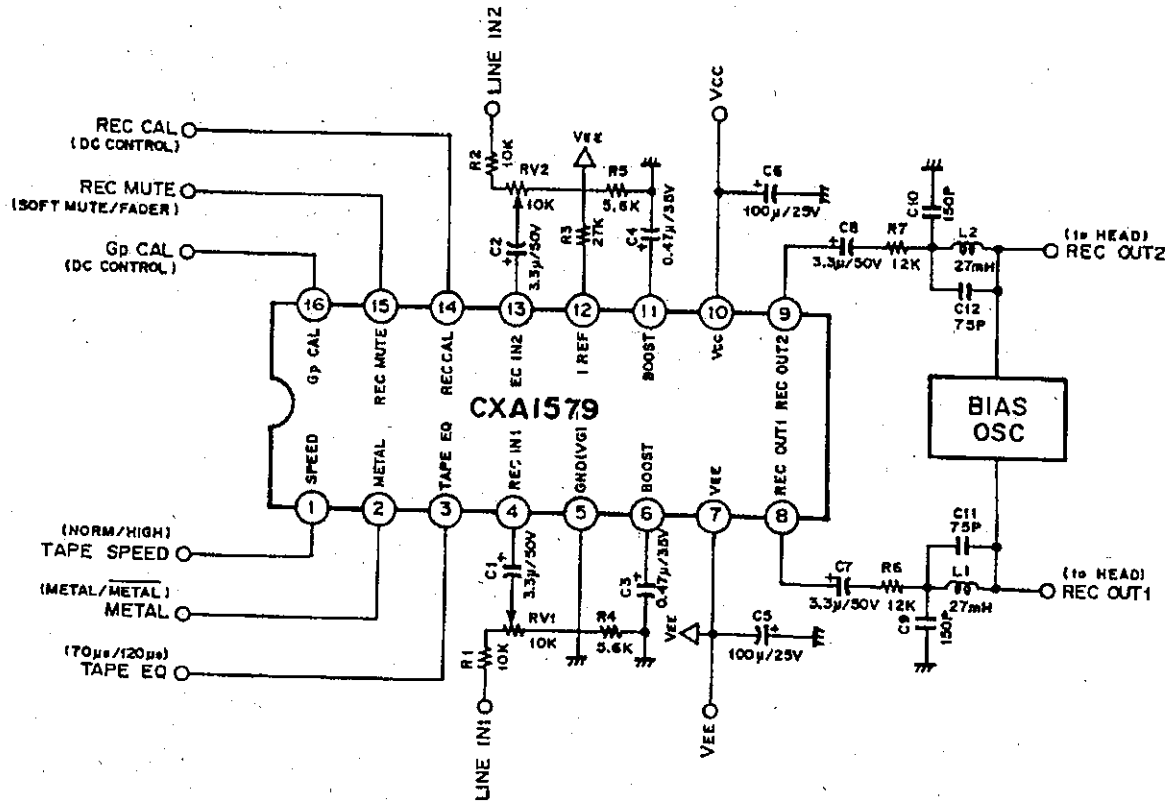

Application Circuit (For single power supply)

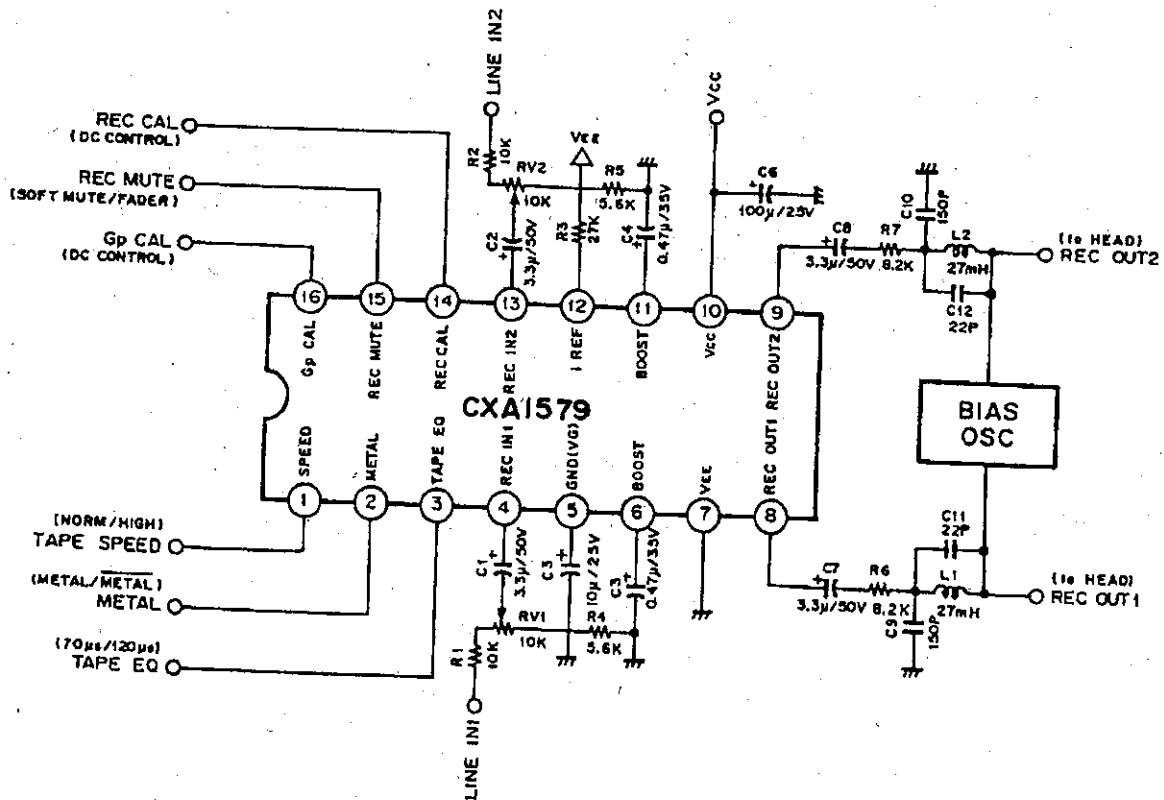

Application circuits shown are typical examples illustrating the operation of the devices. Sony cannot assume responsibility for any problems arising out of the use of these circuits or for any infringement of third party patent and other right due to same.

Frequency characteristics

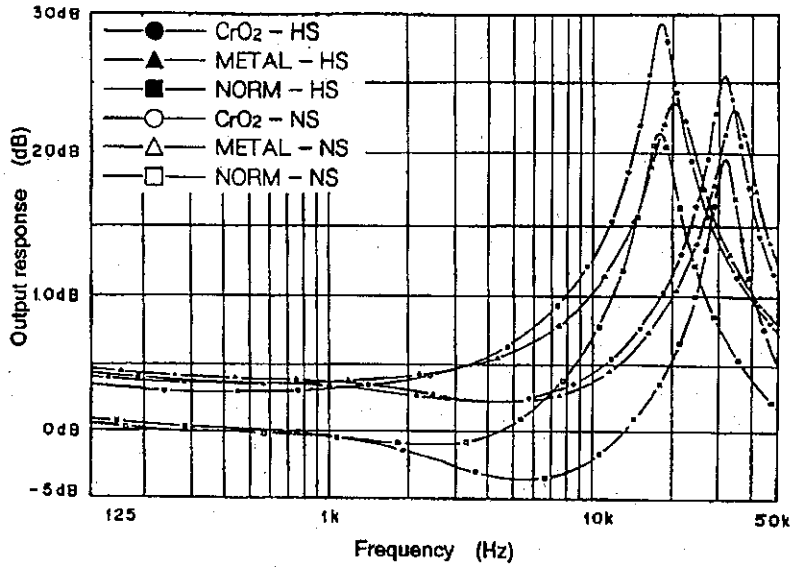

Total higher harmonic distortion

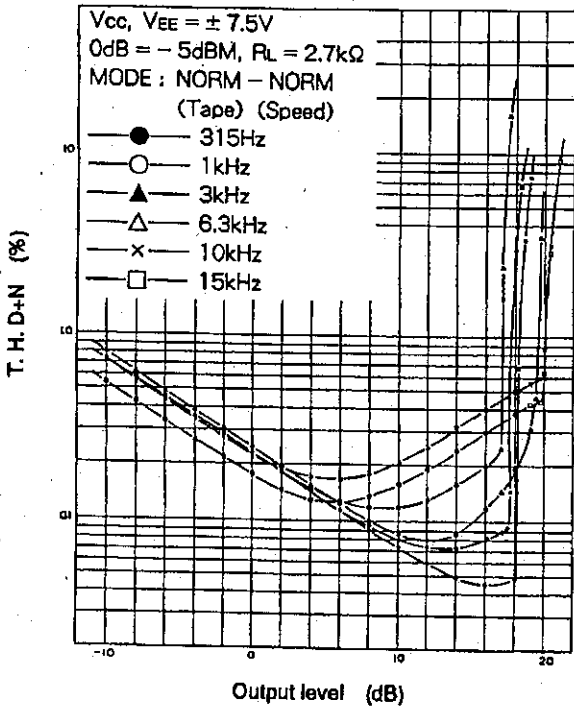

Load characteristics

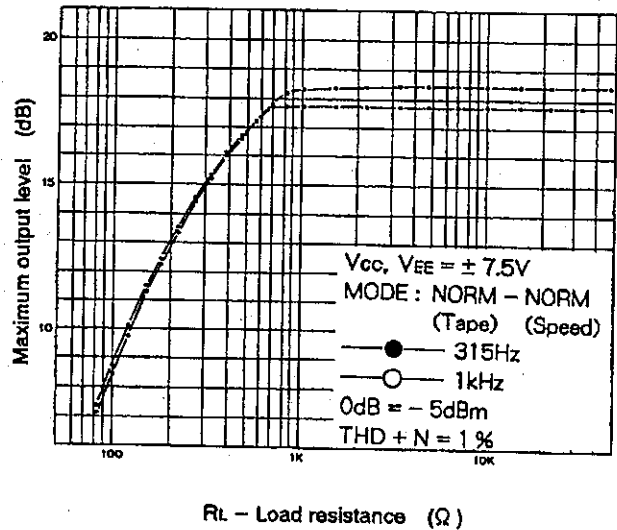

Output level vs. Mute voltage

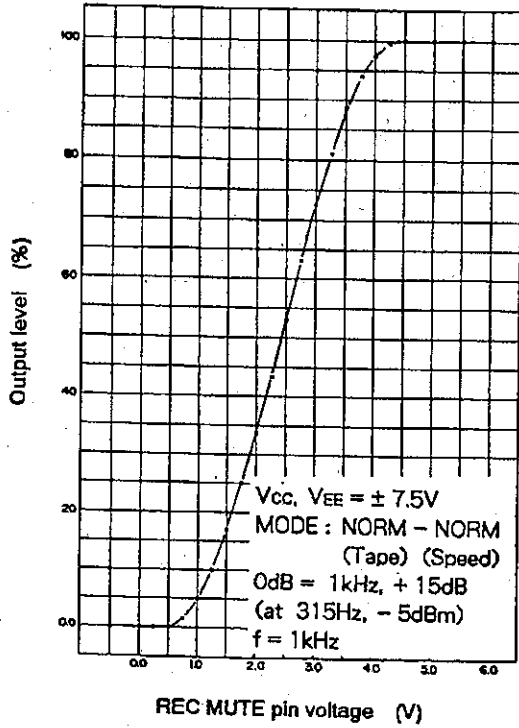

Output level vs. Mute voltage

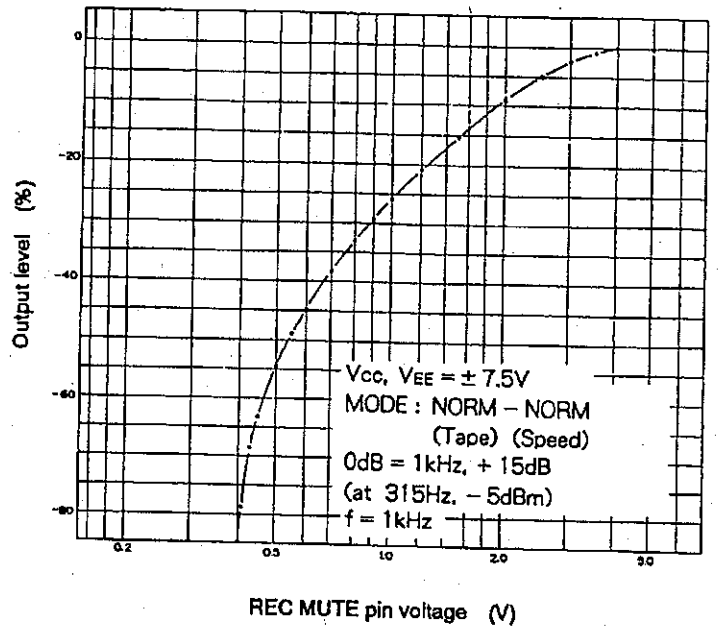

Output level vs. Mute voltage

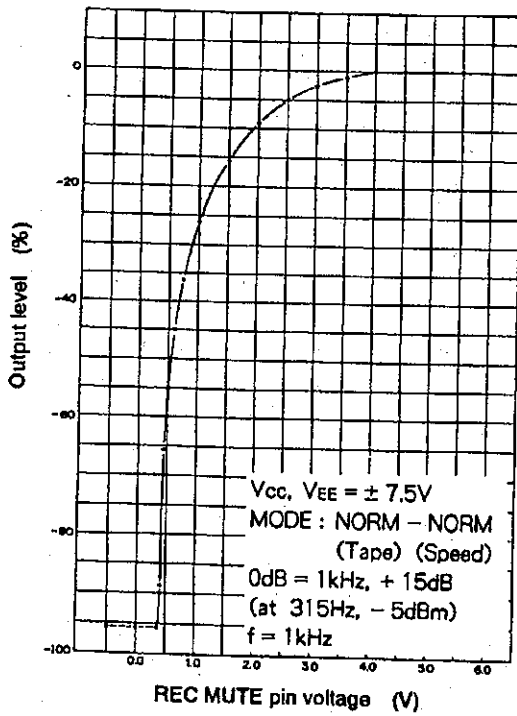

Package OutLine Unit:mm

CXA1579P

16PIN DIP (PLASTIC)

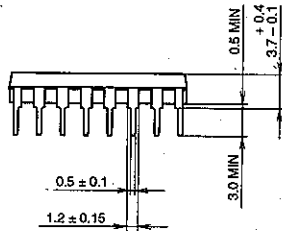
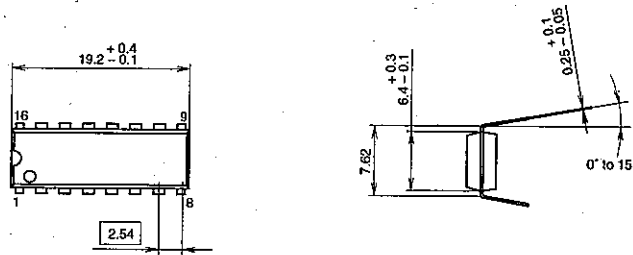

Two kinds of package surface:
 1. All mat surface type.
 2. All mirror surface type.

PACKAGE STRUCTURE

SONY CODE	DIP-16P-01
EIAJ CODE	DIP016-P-0300
JEDEC CODE	Similar to MO-001-AE

PACKAGE MATERIAL	EPOXY RESIN
LEAD TREATMENT	SOLDER PLATING
LEAD MATERIAL	COPPER ALLOY
PACKAGE MASS	1.0 g

16PIN DIP (PLASTIC)

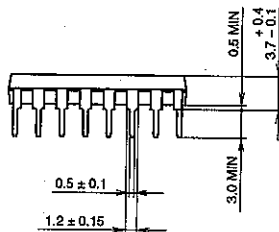
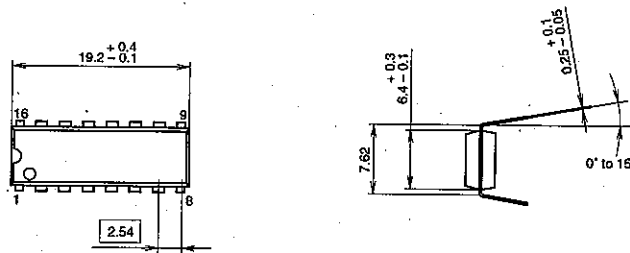

Two kinds of package surface:
 1. All mat surface type.
 2. All mirror surface type.

PACKAGE STRUCTURE

SONY CODE	DIP-16P-01
EIAJ CODE	DIP016-P-0300
JEDEC CODE	Similar to MO-001-AE

PACKAGE MATERIAL	EPOXY RESIN
LEAD TREATMENT	SOLDER PLATING
LEAD MATERIAL	COPPER ALLOY
PACKAGE MASS	1.0 g

LEAD PLATING SPECIFICATIONS

ITEM	SPEC.
LEAD MATERIAL	COPPER ALLOY
SOLDER COMPOSITION	Sn-Bi Bi:1-4wt%
PLATING THICKNESS	5-18µm

Package Outline Unit:mm

CXA1579M

16PIN SOP (PLASTIC)

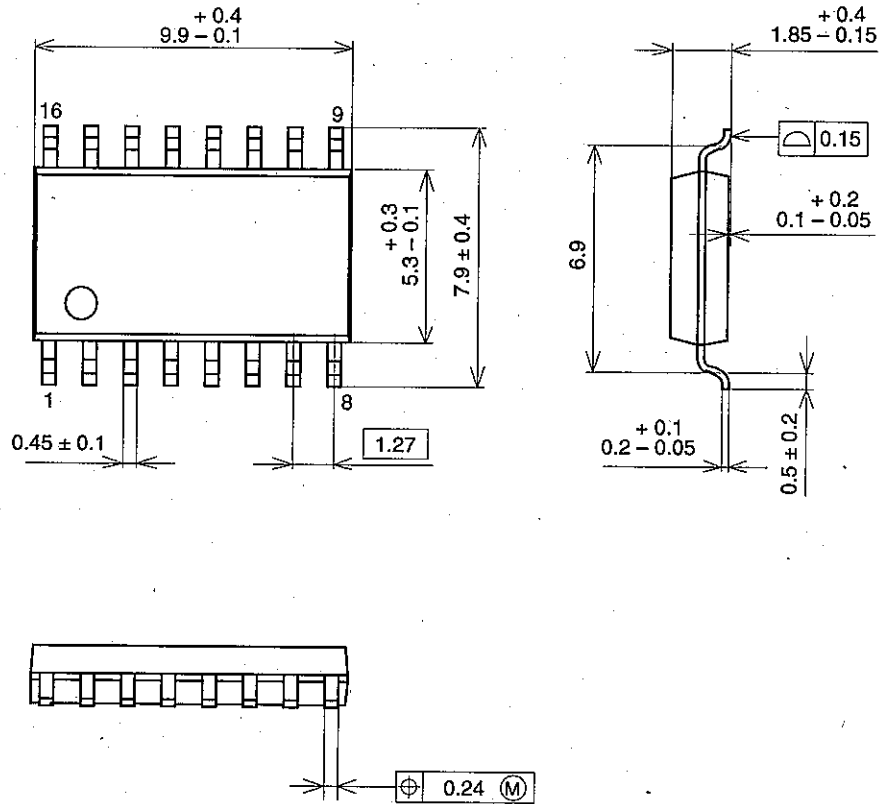

PACKAGE STRUCTURE

SONY CODE	SOP-16P-L01
EIAJ CODE	SOP016-P-0300
JEDEC CODE	

PACKAGE MATERIAL	EPOXY RESIN
LEAD TREATMENT	SOLDER PLATING
LEAD MATERIAL	COPPER ALLOY
PACKAGE MASS	0.2g