

LM131, LM131A, LM231, LM231A, LM331, LM331A

Precision Voltage-to-Frequency Converters

The LM131/LM231/LM331 family of voltage-to-frequency converters are ideally suited for use in simple low-cost circuits for analog-to-digital conversion, precision frequency-to-voltage conversion, long-term integration, linear frequency modulation or demodulation, and many other functions. The output when used as a voltage-to-frequency converter is a pulse train at a frequency precisely proportional to the applied input voltage. Thus, it provides all the inherent advantages of the voltage-to-frequency conversion techniques, and is easy to apply in all standard voltage-to-frequency converter applications. Further, the LM131A/LM231A/LM331A attains a new high level of accuracy versus temperature which could only be attained with expensive voltage-to-frequency modules.

Rochester Electronics Manufactured Components

Rochester branded components are manufactured using either die/wafers purchased from the original suppliers or Rochester wafers recreated from the original IP. All recreations are done with the approval of the OCM.

Parts are tested using original factory test programs or Rochester developed test solutions to guarantee product meets or exceeds the OCM data sheet.

Quality Overview

- ISO-9001
- AS9120 certification
- Qualified Manufacturers List (QML) MIL-PRF-38535
 - Class Q Military
 - Class V Space Level
- Qualified Suppliers List of Distributors (QSLD)
 - Rochester is a critical supplier to DLA and meets all industry and DLA standards.

Rochester Electronics, LLC is committed to supplying products that satisfy customer expectations for quality and are equal to those originally supplied by industry manufacturers.

The original manufacturer's datasheet accompanying this document reflects the performance and specifications of the Rochester manufactured version of this device. Rochester Electronics guarantees the performance of its semiconductor products to the original OEM specifications. 'Typical' values are for reference purposes only. Certain minimum or maximum ratings may be based on product characterization, design, simulation, or sample testing.



T-73-13-03

LM131A/LM131, LM231A/LM231, LM331A/LM331 Precision Voltage-to-Frequency Converters

General Description

The LM131/LM231/LM331 family of voltage-to-frequency converters are ideally suited for use in simple low-cost circuits for analog-to-digital conversion, precision frequency-to-voltage conversion, long-term integration, linear frequency modulation or demodulation, and many other functions. The output when used as a voltage-to-frequency converter is a pulse train at a frequency precisely proportional to the applied input voltage. Thus, it provides all the inherent advantages of the voltage-to-frequency conversion techniques, and is easy to apply in all standard voltage-to-frequency converter applications. Further, the LM131A/LM231A/LM331A attains a new high level of accuracy versus temperature which could only be attained with expensive voltage-to-frequency modules. Additionally the LM131 is ideally suited for use in digital systems at low power supply voltages and can provide low-cost analog-to-digital conversion in microprocessor-controlled systems. And, the frequency from a battery powered voltage-to-frequency converter can be easily channeled through a simple photoisolator to provide isolation against high common mode levels.

The LM131/LM231/LM331 utilizes a new temperature-compensated band-gap reference circuit, to provide excellent accuracy over the full operating temperature range, at power supplies as low as 4.0V. The precision timer circuit

has low bias currents without degrading the quick response necessary for 100 kHz voltage-to-frequency conversion. And the output is capable of driving 3 TTL loads, or a high voltage output up to 40V, yet is short-circuit-proof against V_{CC} .

Features

- Guaranteed linearity 0.01% max
- Improved performance in existing voltage-to-frequency conversion applications
- Split or single supply operation
- Operates on single 5V supply
- Pulse output compatible with all logic forms
- Excellent temperature stability, ± 50 ppm/ $^{\circ}\text{C}$ max
- Low power dissipation, 15 mW typical at 5V
- Wide dynamic range, 100 dB min at 10 kHz full scale frequency
- Wide range of full scale frequency, 1 Hz to 100 kHz
- Low cost

Typical Applications

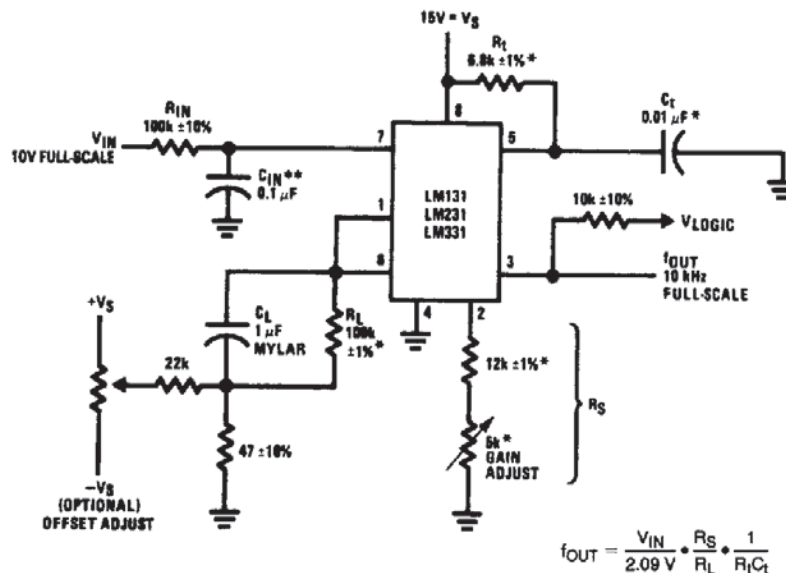

*Use stable components with low temperature coefficients. See Typical Applications section.

**0.1 μF or 1 μF , See "Principles of Operation."

**FIGURE 1. Simple Stand-Alone Voltage-to-Frequency Converter
with $\pm 0.03\%$ Typical Linearity ($f = 10 \text{ Hz}$ to 11 kHz)**

NATL SEMICOND (LINEAR)

Absolute Maximum Ratings (Note 1)

If Military/Aerospace specified devices are required, please contact the National Semiconductor Sales Office/Distributors for availability and specifications.

	LM131A/LM131	LM231A/LM231	LM331A/LM331
Supply Voltage	40V	40V	40V
Output Short Circuit to Ground	Continuous	Continuous	Continuous
Output Short Circuit to V_{CC}	Continuous	Continuous	Continuous
Input Voltage	-0.2V to $+V_S$	-0.2V to $+V_S$	-0.2V to $+V_S$
Operating Ambient Temperature Range	T_{MIN} T_{MAX} -55°C to +125°C	T_{MIN} T_{MAX} -25°C to +85°C	T_{MIN} T_{MAX} 0°C to +70°C
Power Dissipation (P_D at 25°C) and Thermal Resistance (θ_{JA})			
(H Package) P_D θ_{JA}	670 mW 150°C/W	570 mW 150°C/W	570 mW 150°C/W
(N Package) P_D θ_{JA}		1.25W 100°C/W	1.25W 100°C/W
(M Package) P_D θ_{JA}		1.25W 85°C/W	
Lead Temperature (Soldering, 10 sec.)			
Dual-In-Line Package (Plastic)	260°C	260°C	260°C
Metal Can Package (TO-5)	260°C	260°C	260°C
ESD Susceptibility (Note 4)			
Metal Can Package (TO-5)	2000V	2000V	2000V
Other Packages		500V	500V

Electrical Characteristics $T_A = 25^\circ\text{C}$ unless otherwise specified (Note 2)

Parameter	Conditions	Min	Typ	Max	Units
VFC Non-Linearity (Note 3)	$4.5V \leq V_S \leq 20V$		± 0.003	± 0.01	% Full-Scale
	$T_{MIN} \leq T_A \leq T_{MAX}$		± 0.006	± 0.02	% Full-Scale
VFC Non-Linearity In Circuit of Figure 1	$V_S = 15V, f = 10 \text{ Hz to } 11 \text{ kHz}$		± 0.024	± 0.14	% Full-Scale
Conversion Accuracy Scale Factor (Gain) LM131, LM131A, LM231, LM231A LM331, LM331A	$V_{IN} = -10V, R_S = 14 \text{ k}\Omega$	0.95	1.00	1.05	kHz/V
		0.90	1.00	1.10	kHz/V
Temperature Stability of Gain LM131/LM231/LM331 LM131A/LM231A/LM331A	$T_{MIN} \leq T_A \leq T_{MAX}, 4.5V \leq V_S \leq 20V$		± 30	± 150	ppm/°C
			± 20	± 50	ppm/°C
Change of Gain with V_S	$4.5V \leq V_S \leq 10V$ $10V \leq V_S \leq 40V$		0.01	0.1	%/V
			0.006	0.06	%/V
Rated Full-Scale Frequency	$V_{IN} = -10V$	10.0			kHz
Gain Stability vs Time (1000 Hrs)	$T_{MIN} \leq T_A \leq T_{MAX}$		± 0.02		% Full-Scale
Overrange (Beyond Full-Scale) Frequency	$V_{IN} = -11V$	10			%
INPUT COMPARATOR					
Offset Voltage LM131/LM231/LM331 LM131A/LM231A/LM331A	$T_{MIN} \leq T_A \leq T_{MAX}$ $T_{MIN} \leq T_A \leq T_{MAX}$		± 3	± 10	mV
			± 4	± 14	mV
			± 3	± 10	mV
Bias Current			-80	-300	nA
Offset Current			± 8	± 100	nA
Common-Mode Range	$T_{MIN} \leq T_A \leq T_{MAX}$	-0.2		$V_{CC} - 2.0$	V

Electrical Characteristics $T_A = 25^\circ\text{C}$ unless otherwise specified (Note 2) (Continued)

Parameter	Conditions	Min	Typ	Max	Units
TIMER					
Timer Threshold Voltage, Pin 5		0.63	0.667	0.70	$\times V_S$
Input Bias Current, Pin 5	$V_S = 15\text{V}$ $0\text{V} \leq V_{\text{PIN}5} \leq 9.9\text{V}$		± 10	± 100	nA
LM131/LM231/LM331	$V_{\text{PIN}5} = 10\text{V}$		200	1000	nA
LM131A/LM231A/LM331A	$V_{\text{PIN}5} = 10\text{V}$		200	500	nA
$V_{\text{SAT PIN}5}$ (Reset)	$I = 5\text{ mA}$		0.22	0.5	V
CURRENT SOURCE (Pin 1)					
Output Current	$R_S = 14\text{ k}\Omega$, $V_{\text{PIN}1} = 0$				
LM131, LM131A, LM231, LM231A		126	135	144	μA
LM331, LM331A		116	136	156	μA
Change with Voltage	$0\text{V} \leq V_{\text{PIN}1} \leq 10\text{V}$		0.2	1.0	μA
Current Source OFF Leakage					
LM131, LM131A			0.01	1.0	nA
LM231, LM231A, LM331, LM331A			0.02	10.0	nA
All Devices	$T_A = T_{\text{MAX}}$		2.0	50.0	nA
Operating Range of Current (Typical)			(10 to 500)		μA
REFERENCE VOLTAGE (Pin 2)					
LM131, LM131A, LM231, LM231A		1.76	1.89	2.02	V_{DC}
LM331, LM331A		1.70	1.89	2.08	V_{DC}
Stability vs Temperature			± 60		ppm/ $^\circ\text{C}$
Stability vs Time, 1000 Hours			± 0.1		%
LOGIC OUTPUT (Pin 3)					
V_{SAT}	$I = 5\text{ mA}$ $I = 3.2\text{ mA}$ (2 TTL Loads), $T_{\text{MIN}} \leq T_A \leq T_{\text{MAX}}$		0.15	0.50	V
OFF Leakage			0.10	0.40	V
			± 0.05	1.0	μA
SUPPLY CURRENT					
LM131, LM131A, LM231, LM231A	$V_S = 5\text{V}$ $V_S = 40\text{V}$	2.0	3.0	4.0	mA
LM331, LM331A	$V_S = 5\text{V}$ $V_S = 40\text{V}$	2.5	4.0	6.0	mA
		1.5	3.0	6.0	mA
		2.0	4.0	8.0	mA

Note 1: Absolute Maximum Ratings indicate limits beyond which damage to the device may occur. DC and AC electrical specifications do not apply when operating the device beyond its specified operating conditions.

Note 2: All specifications apply in the circuit of Figure 3, with $4.0\text{V} \leq V_S \leq 40\text{V}$, unless otherwise noted.

Note 3: Nonlinearity is defined as the deviation of I_{OUT} from $V_{\text{IN}} \times (10\text{ kHz} / -10\text{ V}_{\text{DC}})$ when the circuit has been trimmed for zero error at 10 Hz and at 10 kHz, over the frequency range 1 Hz to 11 kHz. For the timing capacitor, C_T , use NPO ceramic, Teflon®, or polystyrene.

Note 4: Human body model, 100 pF discharged through a 1.5 k Ω resistor.

NATL SEMICON (LINEAR)

LM131A/LM131/LM231A/LM231/LM331A/LM331

NATL SEMICOND (LINEAR)

Functional Block Diagram

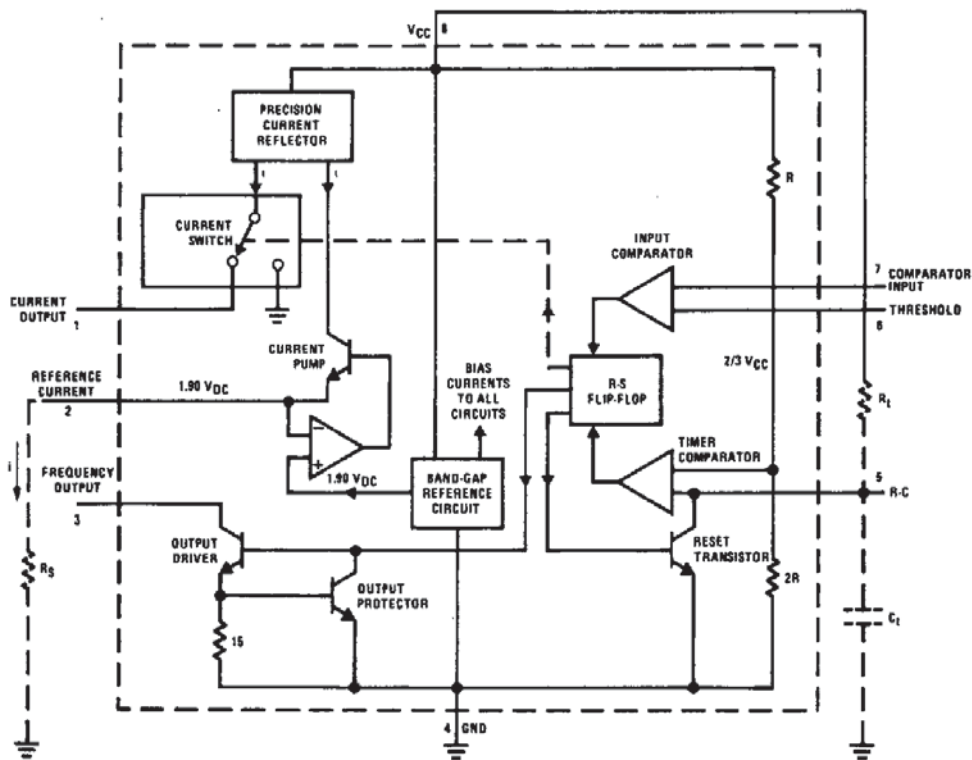

Pin numbers apply to 8-pin packages only. See connection diagram for LM231WM pin numbers.

FIGURE 1a

TL/H/5680-2

Typical Performance Characteristics

(All electrical characteristics apply for the circuit of *Figure 3*, unless otherwise noted.)

Nonlinearity Error, LM131 Family, as Precision V-to-F Converter (*Figure 3*)

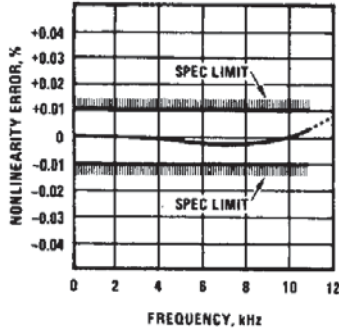

Nonlinearity Error, LM131 Family

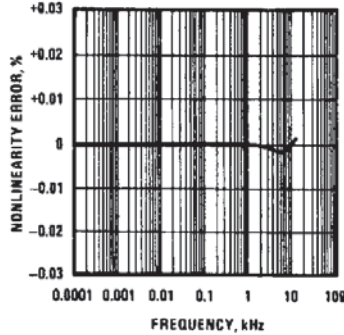

Nonlinearity vs Power Supply Voltage

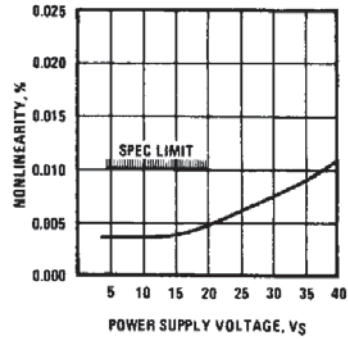

Frequency vs Temperature, LM131A

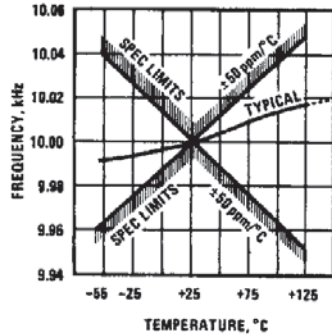

VREF vs Temperature, LM131A

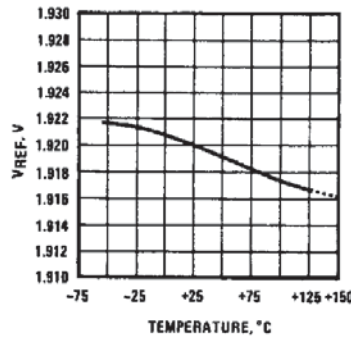

Output Frequency vs VSUPPLY

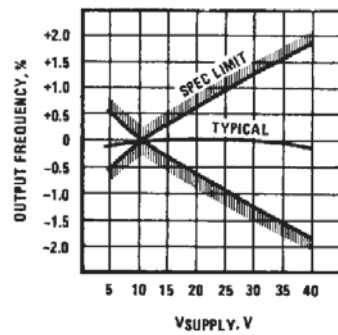

100 kHz Nonlinearity Error, LM131 Family (*Figure 4*)

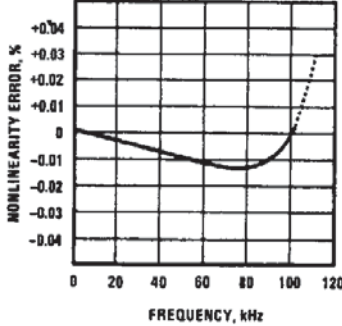

Nonlinearity Error, LM131 (*Figure 1*)

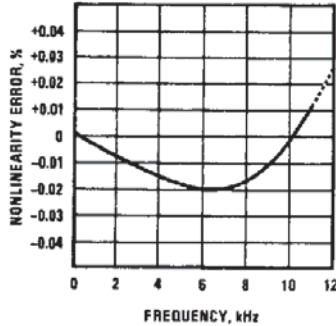

Input Current (Pins 6, 7) vs Temperature

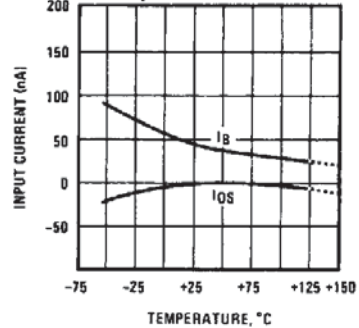

Power Drain vs VSUPPLY

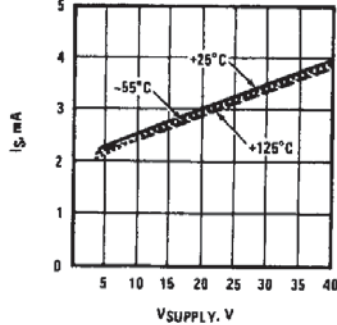

Output Saturation Voltage vs IOUT (Pin 3)

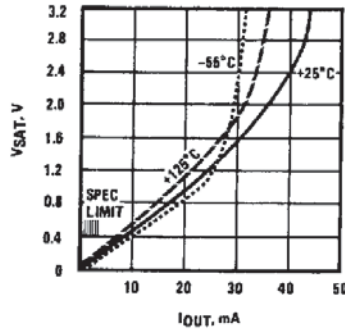

Nonlinearity Error, Precision F-to-V Converter (*Figure 6*)

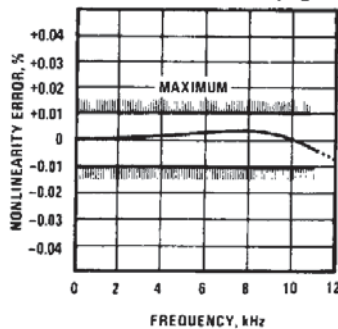

TL/H/5680-3

Typical Applications (Continued)

PRINCIPLES OF OPERATION OF A SIMPLIFIED VOLTAGE-TO-FREQUENCY CONVERTER

The LM131 is a monolithic circuit designed for accuracy and versatile operation when applied as a voltage-to-frequency (V-to-F) converter or as a frequency-to-voltage (F-to-V) converter. A simplified block diagram of the LM131 is shown in *Figure 2* and consists of a switched current source, input comparator, and 1-shot timer.

The operation of these blocks is best understood by going through the operating cycle of the basic V-to-F converter, *Figure 2*, which consists of the simplified block diagram of the LM131 and the various resistors and capacitors connected to it.

The voltage comparator compares a positive input voltage, V_1 , at pin 7 to the voltage, V_x , at pin 6. If V_1 is greater, the comparator will trigger the 1-shot timer. The output of the timer will turn ON both the frequency output transistor and the switched current source for a period $t = 1.1 R_1 C_1$. During this period, the current i will flow out of the switched current source and provide a fixed amount of charge, $Q = i \times t$, into the capacitor, C_L . This will normally charge V_x up to a higher level than V_1 . At the end of the timing period, the current i will turn OFF, and the timer will reset itself.

Now there is no current flowing from pin 1, and the capacitor C_L will be gradually discharged by R_L until V_x falls to the level of V_1 . Then the comparator will trigger the timer and start another cycle.

The current flowing into C_L is exactly $I_{AVE} = i \times (1.1 \times R_1 C_1) \times f$, and the current flowing out of C_L is exactly $V_x / R_L \cong V_{IN} / R_L$. If V_{IN} is doubled, the frequency will double to maintain this balance. Even a simple V-to-F converter can provide a frequency precisely proportional to its input voltage over a wide range of frequencies.

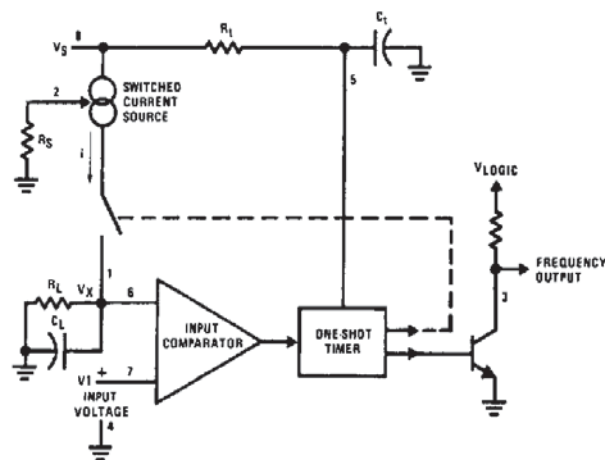

FIGURE 2. Simplified Block Diagram of Stand-Alone Voltage-to-Frequency Converter Showing LM131 and External Components

DETAIL OF OPERATION, FUNCTIONAL BLOCK DIAGRAM (FIGURE 1a)

The block diagram shows a band gap reference which provides a stable $1.9 V_{DC}$ output. This $1.9 V_{DC}$ is well regulated over a V_S range of 3.9V to 40V. It also has a flat, low temperature coefficient, and typically changes less than $1/2\%$ over a 100°C temperature change.

The current pump circuit forces the voltage at pin 2 to be at 1.9V, and causes a current $i = 1.90V/R_S$ to flow. For $R_S = 14k$, $i = 135 \mu\text{A}$. The precision current reflector provides a current equal to i to the current switch. The current switch switches the current to pin 1 or to ground depending on the state of the R_S flip-flop.

The timing function consists of an R_S flip-flop, and a timer comparator connected to the external $R_1 C_1$ network. When the input comparator detects a voltage at pin 7 higher than pin 6, it sets the R_S flip-flop which turns ON the current switch and the output driver transistor. When the voltage at pin 5 rises to $2/3 V_{CC}$, the timer comparator causes the R_S flip-flop to reset. The reset transistor is then turned ON and the current switch is turned OFF.

However, if the input comparator still detects pin 7 higher than pin 6 when pin 5 crosses $2/3 V_{CC}$, the flip-flop will not be reset, and the current at pin 1 will continue to flow, in its attempt to make the voltage at pin 6 higher than pin 7. This condition will usually apply under start-up conditions or in the case of an overload voltage at signal input. It should be noted that during this sort of overload, the output frequency will be 0; as soon as the signal is restored to the working range, the output frequency will be resumed.

The output driver transistor acts to saturate pin 3 with an ON resistance of about 50Ω . In case of overvoltage, the output current is actively limited to less than 50 mA.

The voltage at pin 2 is regulated at $1.90 V_{DC}$ for all values of i between $10 \mu\text{A}$ to $500 \mu\text{A}$. It can be used as a voltage reference for other components, but care must be taken to ensure that current is not taken from it which could reduce the accuracy of the converter.

PRINCIPLES OF OPERATION OF BASIC VOLTAGE-TO-FREQUENCY CONVERTER (FIGURE 1)

The simple stand-alone V-to-F converter shown in *Figure 1* includes all the basic circuitry of *Figure 2* plus a few components for improved performance.

A resistor, $R_{IN} = 100 k\Omega \pm 10\%$, has been added in the path to pin 7, so that the bias current at pin 7 (-80 nA typical) will cancel the effect of the bias current at pin 6 and help provide minimum frequency offset.

The resistance R_S at pin 2 is made up of a $12 k\Omega$ fixed resistor plus a $5 k\Omega$ (cermet, preferably) gain adjust rheostat. The function of this adjustment is to trim out the gain tolerance of the LM131, and the tolerance of R_1 , R_L and C_1 .

TL/H/5680-4

Typical Applications (Continued)

For best results, all the components should be stable low-temperature-coefficient components, such as metal-film resistors. The capacitor should have low dielectric absorption; depending on the temperature characteristics desired, NPO ceramic, polystyrene, Teflon or polypropylene are best suited.

A capacitor C_{IN} is added from pin 7 to ground to act as a filter for V_{IN} . A value of $0.01 \mu\text{F}$ to $0.1 \mu\text{F}$ will be adequate in most cases; however, in cases where better filtering is required, a $1 \mu\text{F}$ capacitor can be used. When the RC time constants are matched at pin 6 and pin 7, a voltage step at V_{IN} will cause a step change in f_{OUT} . If C_{IN} is much less than C_L , a step at V_{IN} may cause f_{OUT} to stop momentarily.

A 47Ω resistor, in series with the $1 \mu\text{F}$ C_L , is added to give hysteresis effect which helps the input comparator provide the excellent linearity (0.03% typical).

DETAIL OF OPERATION OF PRECISION V-TO-F CONVERTER (FIGURE 3)

In this circuit, integration is performed by using a conventional operational amplifier and feedback capacitor, C_F . When the integrator's output crosses the nominal threshold level at pin 6 of the LM131, the timing cycle is initiated.

The average current fed into the op amp's summing point (pin 2) is $i \times (1.1 R_T C_T) \times f$ which is perfectly balanced with $-V_{IN}/R_{IN}$. In this circuit, the voltage offset of the LM131 input comparator does not affect the offset or accuracy of the V-to-F converter as it does in the stand-alone V-to-F converter; nor does the LM131 bias current or offset current. Instead, the offset voltage and offset current of the operational amplifier are the only limits on how small the signal can be accurately converted. Since op amps with voltage offset well below 1 mV and offset currents well below 2 nA are available at low cost, this circuit is recommended for best accuracy for small signals. This circuit also responds immediately to any change of input signal (which a stand-alone circuit does not) so that the output frequency will be an accurate representation of V_{IN} , as quickly as 2 output pulses' spacing can be measured.

In the precision mode, excellent linearity is obtained because the current source (pin 1) is always at ground potential and that voltage does not vary with V_{IN} or f_{OUT} . (In the stand-alone V-to-F converter, a major cause of non-linearity is the output impedance at pin 1 which causes i to change as a function of V_{IN} .)

The circuit of Figure 4 operates in the same way as Figure 3, but with the necessary changes for high speed operation.

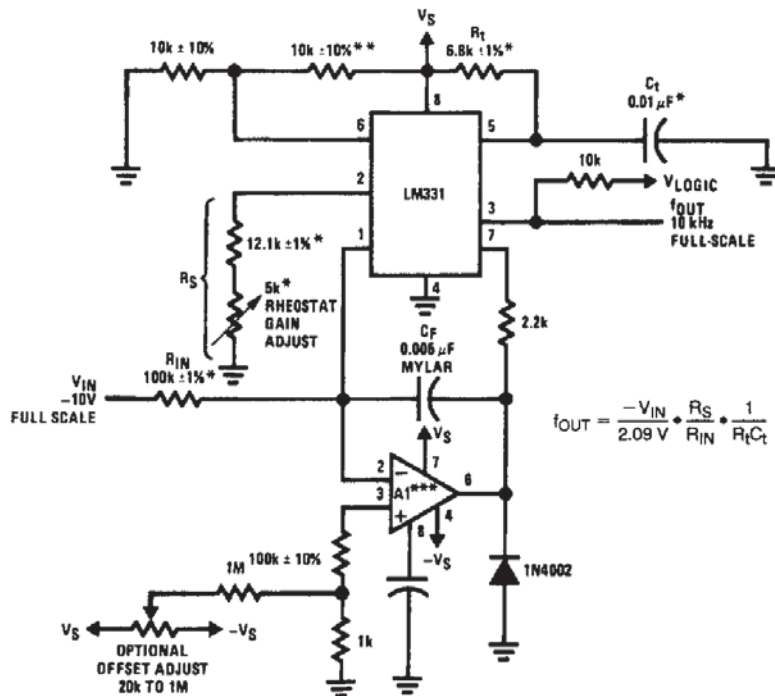

$$f_{OUT} = \frac{-V_{IN}}{2.09 \text{ V}} \cdot \frac{R_S}{R_{IN}} \cdot \frac{1}{R_T C_T}$$

TL/H/5680-5

*Use stable components with low temperature coefficients. See Typical Applications section.

**This resistor can be 5 k Ω or 10 k Ω for $V_S = 8\text{V}$ to 22V, but must be 10 k Ω for $V_S = 4.5\text{V}$ to 8V.

***Use low offset voltage and low offset current op amps for A1: recommended types LM108, LM308A, LF411A

FIGURE 3. Standard Test Circuit and Applications Circuit, Precision Voltage-to-Frequency Converter

Typical Applications (Continued)

DETAILS OF OPERATION, FREQUENCY-TO-VOLTAGE CONVERTERS (FIGURES 5 AND 6)

In these applications, a pulse input at f_{IN} is differentiated by a C-R network and the negative-going edge at pin 6 causes the input comparator to trigger the timer circuit. Just as with a V-to-F converter, the average current flowing out of pin 1 is $I_{AVERAGE} = i \times (1.1 R_T C_T) \times f$.

In the simple circuit of FIGURE 5, this current is filtered in the network $R_L = 100\text{ k}\Omega$ and $1\ \mu\text{F}$. The ripple will be less than 10 mV peak, but the response will be slow, with a

NATL SEMICOND (LINEAR)

0.1 second time constant, and settling of 0.7 second to 0.1% accuracy.

In the precision circuit, an operational amplifier provides a buffered output and also acts as a 2-pole filter. The ripple will be less than 5 mV peak for all frequencies above 1 kHz, and the response time will be much quicker than in Figure 5. However, for input frequencies below 200 Hz, this circuit will have worse ripple than Figure 5. The engineering of the filter time-constants to get adequate response and small enough ripple simply requires a study of the compromises to be made. Inherently, V-to-F converter response can be fast, but F-to-V response can not.

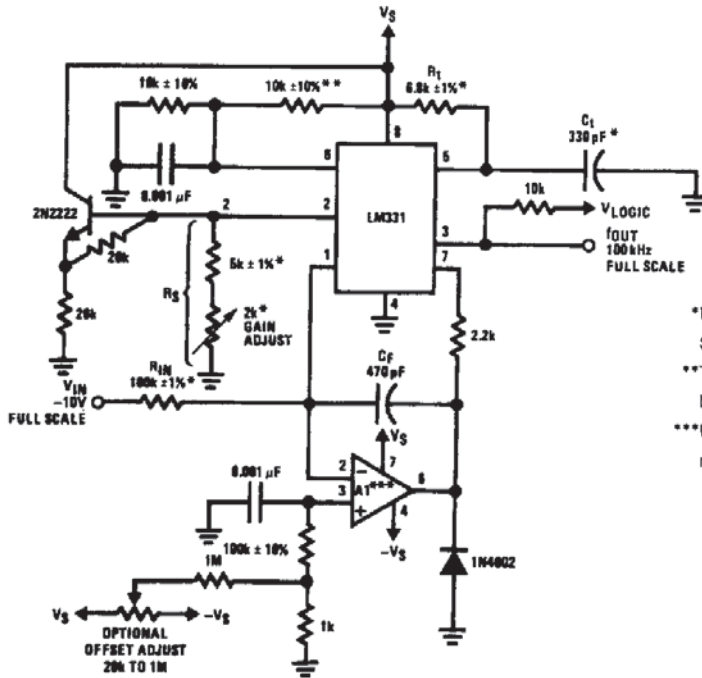

- *Use stable components with low temperature coefficients. See Typical Applications section.
- **This resistor can be 5 kΩ or 10 kΩ for $V_S = 8\text{V}$ to 22V , but must be 10 kΩ for $V_S = 4.5\text{V}$ to 8V .
- ***Use low offset voltage and low offset current op amps for A1: recommended types LF411A or LF356.

FIGURE 4. Precision Voltage-to-Frequency Converter, 100 kHz Full-Scale, ±0.03% Non-Linearity

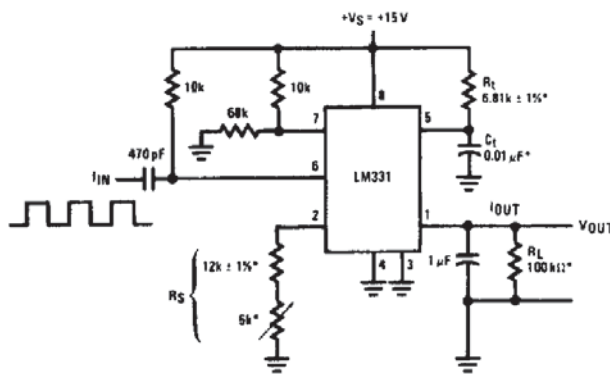

$$V_{OUT} = f_{IN} \times 2.09V \times \frac{R_L}{R_S} \times (R_T C_T)$$

*Use stable components with low temperature coefficients.

FIGURE 5. Simple Frequency-to-Voltage Converter, 10 kHz Full-Scale, ±0.06% Non-Linearity

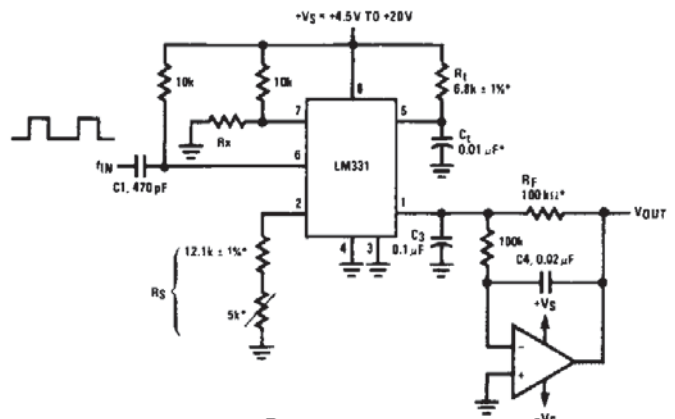

$$V_{OUT} = -f_{IN} \times 2.09V \times \frac{R_F}{R_S} \times (R_T C_T)$$

$$\text{SELECT } R_x = \frac{(V_S - 2V)}{0.2\text{ mA}}$$

*Use stable components with low temperature coefficients.

FIGURE 6. Precision Frequency-to-Voltage Converter, 10 kHz Full-Scale with 2-Pole Filter, ±0.01% Non-Linearity Maximum

Typical Applications (Continued)

Light Intensity to Frequency Converter

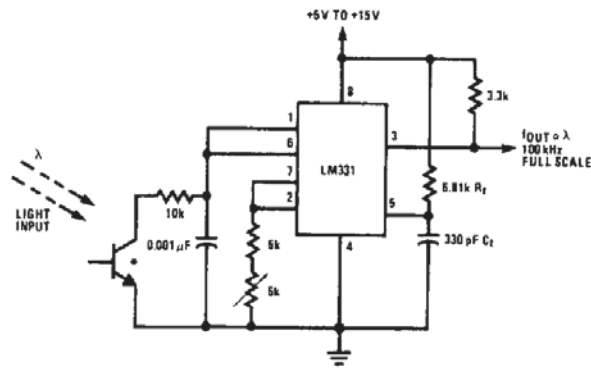

TL/H/5680-9

*L14F-1, L14G-1 or L14H-1, photo transistor (General Electric Co.) or similar

Temperature to Frequency Converter

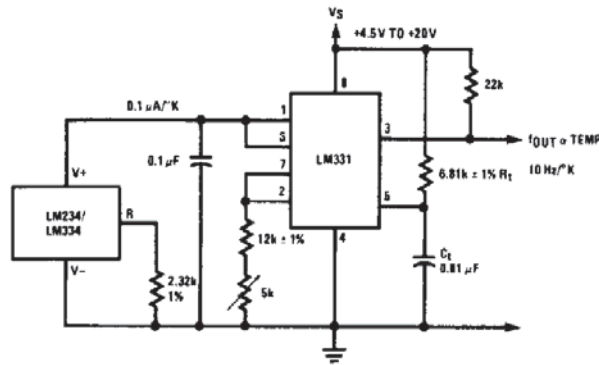

TL/H/5680-10

Long-Term Digital Integrator Using VFC

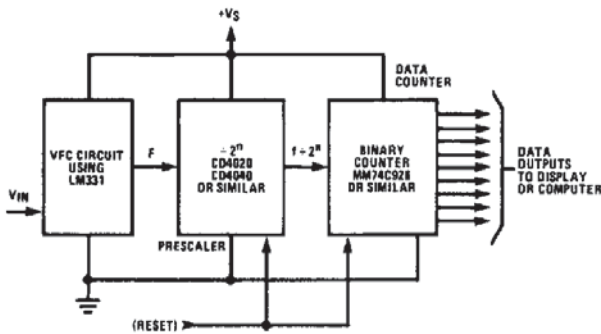

TL/H/5680-11

Basic Analog-to-Digital Converter Using Voltage-to-Frequency Converter

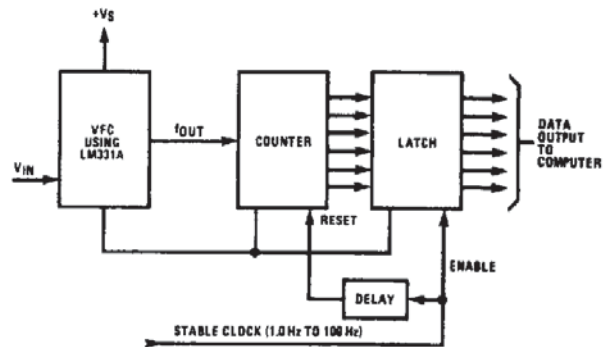

TL/H/5680-12

Typical Applications (Continued)

Analog-to-Digital Converter with Microprocessor

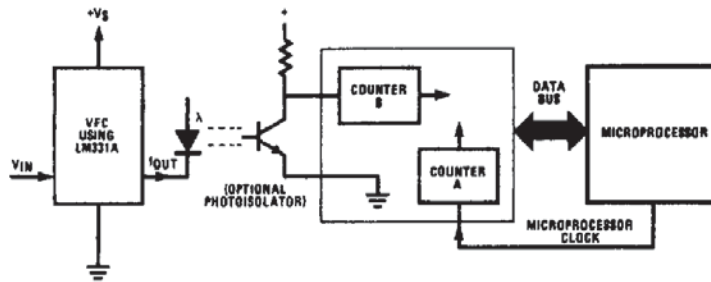

TL/H/5680-13

Remote Voltage-to-Frequency Converter with 2-Wire Transmitter and Receiver

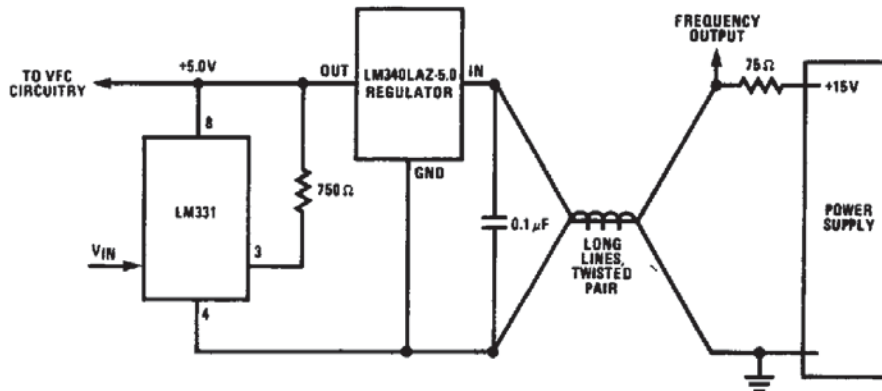

TL/H/5680-14

Voltage-to-Frequency Converter with Square-Wave Output Using 2 Flip-Flop

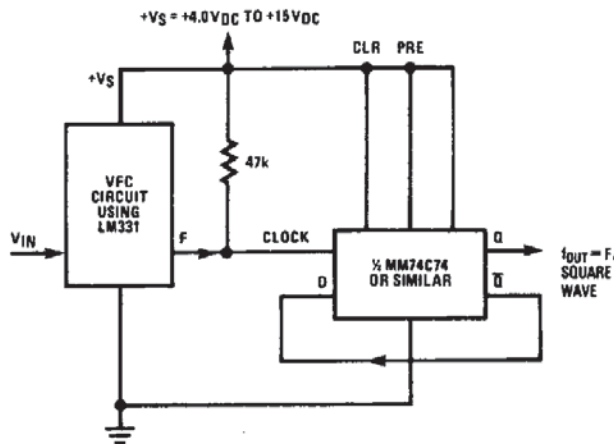

TL/H/5680-15

Voltage-to-Frequency Converter with Isolators

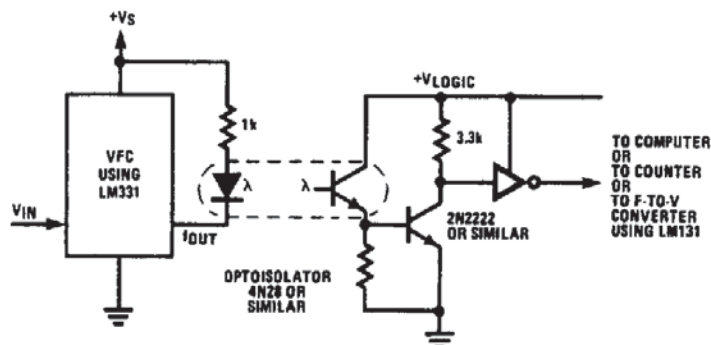

TL/H/5680-16

NATL SEMICOND (LINEAR)

Typical Applications (Continued)

Voltage-to-Frequency Converter with Isolators

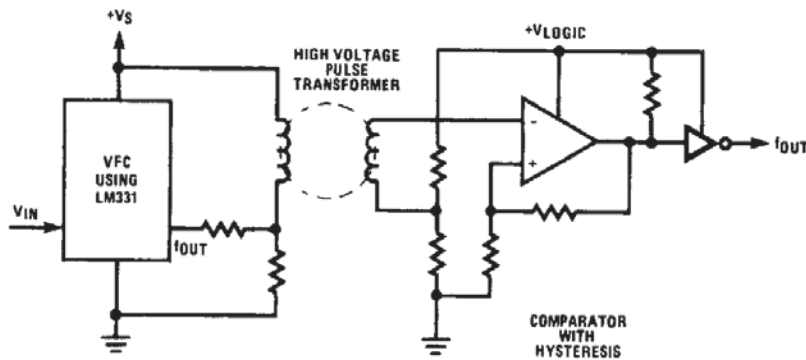

TL/H/5680-17

Voltage-to-Frequency Converter with Isolators

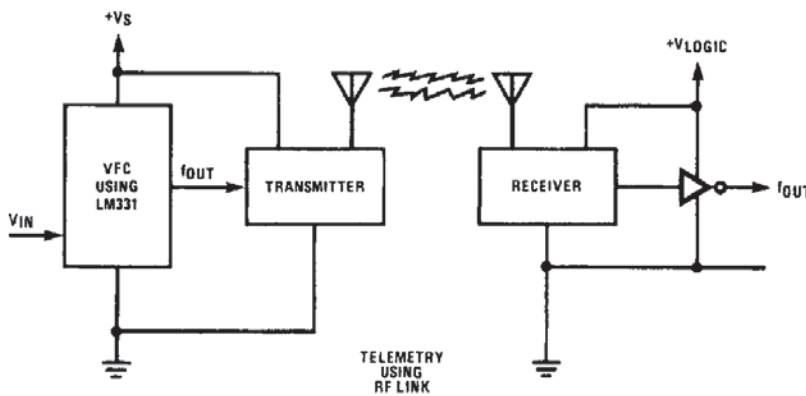

TL/H/5680-18

Voltage-to-Frequency Converter with Isolators

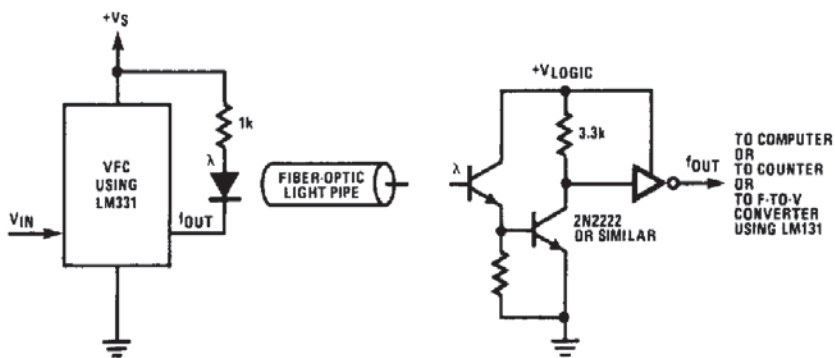

TL/H/5680-19

LM131A/LM131H/LM231A/LM231H/LM331A/LM331H

Connection Diagrams

NATL SEMICOND (LINEAR)

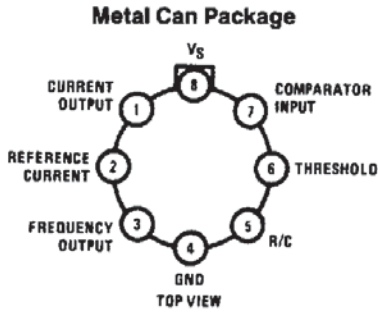

Note: Metal case is connected to pin 4 (GND.)

TL/H/5680-20

Order Number LM131AH, LM131H, LM231AH,
LM231H, LM331AH or LM331H
See NS Package Number H08C

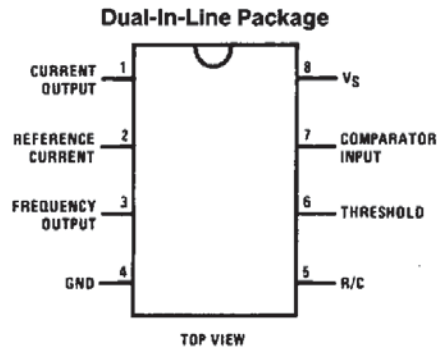

TL/H/5680-21

Order Number LM231AN, LM231N, LM331AN,
or LM331N
See NS Package Number N08E

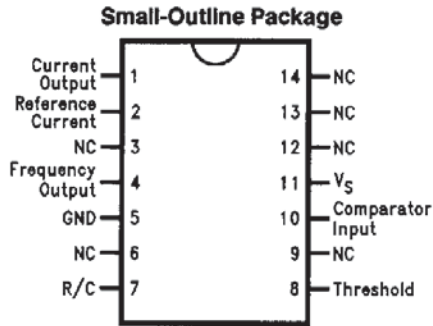

TL/H/5680-24

Order Number LM231WM
See NS Package Number M14B

Schematic Diagram

LM131A/LM131/LM231A/LM231/LM331A/LM331

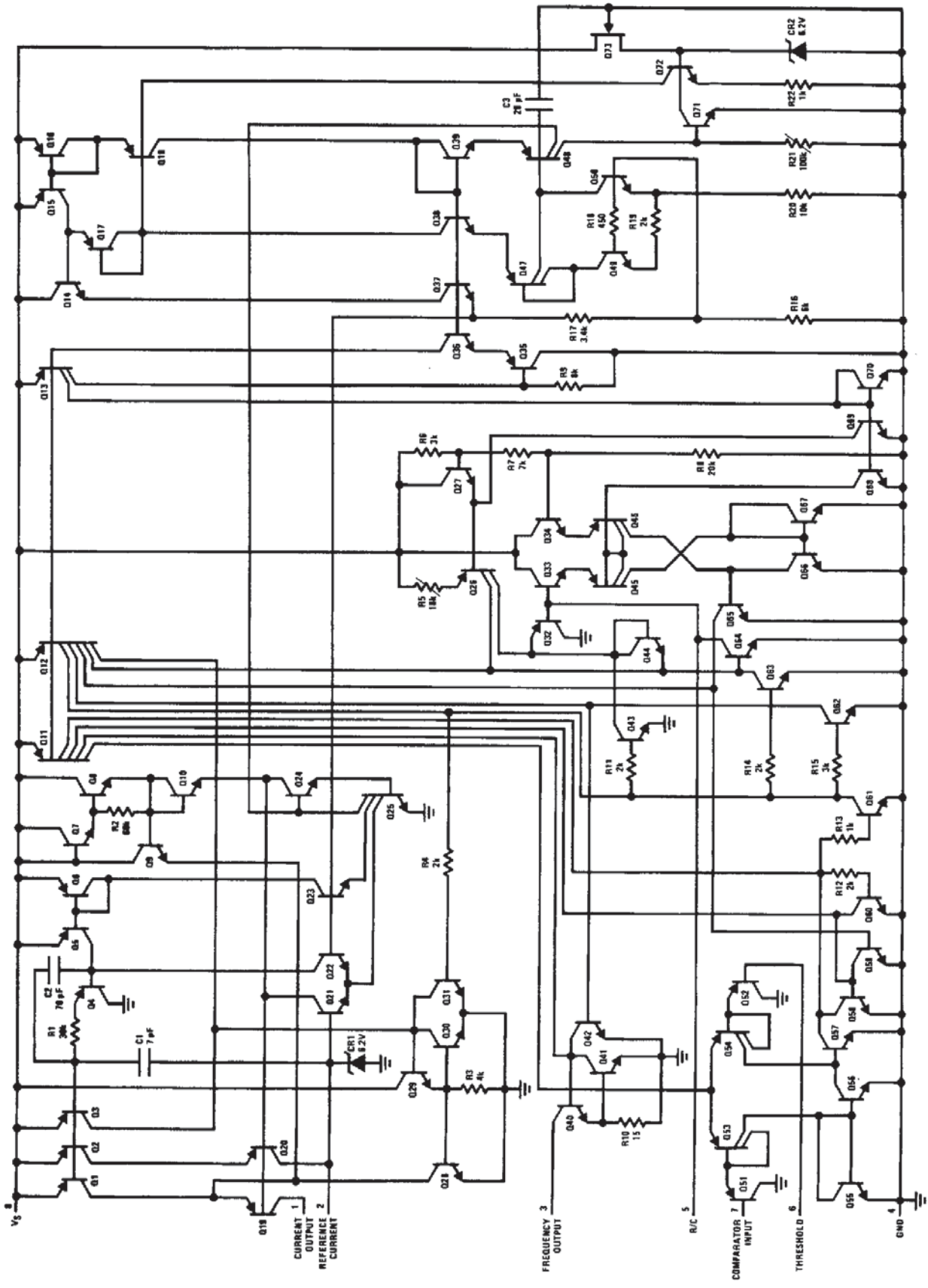

TL/H/5680-22