

AN7082K/S

Pre/Power Amplifier, Governor Single Chip IC for 3V Headphone Stereo

■ Description

The AN7082K/S are the monolithic integrated circuits most suitable for stereo headphone cassette player with integrated pre-amp., power amp., motor governor into a single chip and built-in electronic VR.

■ Features

- Wide operating supply voltage range:
 $V_{cc(opr)} = 1.8V \sim 6V$
- Fewer peripheral parts
- Both channel VR control by single string VR is possible due to electronic VR built-in
- Available for graphic equalizer

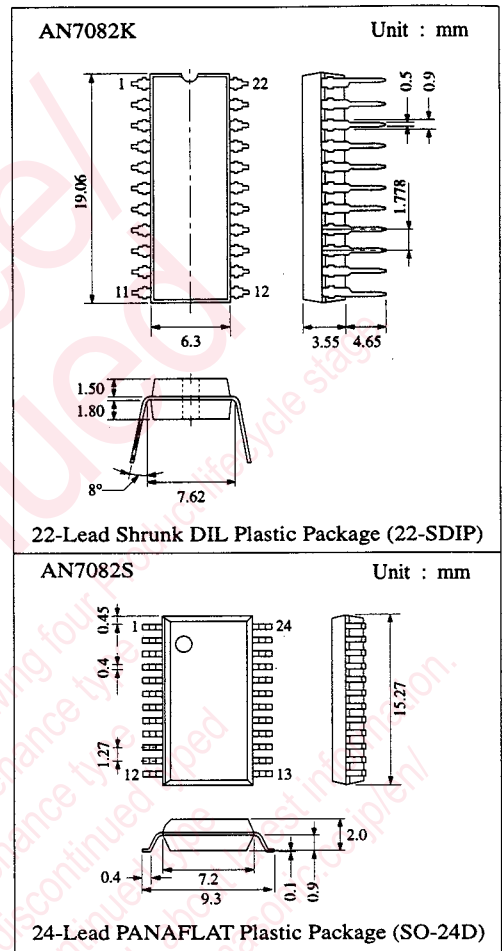

■ Block Diagram

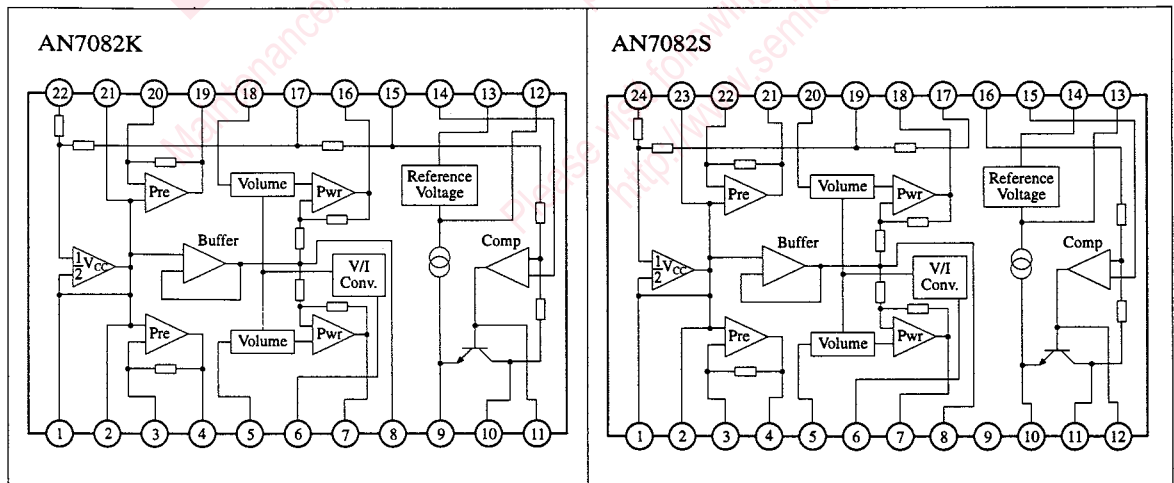

■ Absolute Maximum Ratings (Ta=25°C)

Item	Symbol	Rating	Unit
Supply Voltage	V _{CC}	7	V
Supply Current	I _{CC}	1000	mA
Power Dissipation	P _D	1000	mW
Operating Ambient Temperature	Topr	-25 ~ +75	°C
Storage Temperature	Tstg	-55 ~ +150	°C

Operating Supply Voltage Range: V_{CC} = 1.8V ~ 6.0V

■ Electrical Characteristics (Ta=25°C, V_{CC}=3V, f=1kHz, R_L=32Ω, Volume Max.)

Item	Symbol	Condition	min.	typ.	max.	Unit
Quiescent Current	I _{CQ}	V _{in} = 0V, I _m = 0mA	10	20	35	mA
Pre Amplifier						
Close Loop Gain	G _{VC}	V _O = 0.3V	34	37.5	40	dB
Maximum Output Voltage	V _{O(max)}	THD = 1%	0.6	0.8		V
Total Harmonic Distortion	THD	V _O = 300mV		0.05	0.5	%
Input Noise Voltage	V _{ni}	V _{in} = 0V, R _g = 2.2kΩ, BPF (300Hz ~ 20kHz)		1.8	5.0	μV
Channel Balance	CB	V _{in} = 5mV	-2	0	+2	dB
Attenuator						
Maximum Attenuation	V _{a(max)}	V _O = 0.4V, Pin 6 = 0	60	65		dB
Power Amplifier						
Voltage Gain	G _v	P _{out} = 5mW	25.5	28	30.5	dB
Maximum Power	P _O	THD = 10%, R _L = 32Ω	15	20		mW
Total Harmonic Distortion	THD	P _{out} = 5mW		0.2	1.0	%
Channel Balance	CB	V _O = 0.4V	-2	0	+2	dB
Output Noise Voltage	V _{no}	BPF (300Hz ~ 20kHz)		0.3	0.4	mV
Ripple Rejection	RR	f = 100Hz, 50mV	34	40		dB
Crosstalk	CT	V _O = 0.6V	25	35		dB
Motor Governor						
Load Regulation 1	$\frac{\Delta V_a}{V_a} / \Delta I_a$	I ₁₀ = 30mA ~ 200mA		0.01	0.1	%/mA
Line Regulation 1	$\frac{\Delta V_a}{V_a} / \Delta V_{CC}$	I _m = 50mA, V _{CC} = 1.8 ~ 6.0V		0.1	1.0	%/V
Reference Voltage	V _{REF}	I _m = 100mA, R ₁₃₋₁₂ > 10kΩ		1.28		V
Saturation Voltage	V _{sat}	I _m = 100mA, 1.8V, R _a = 4.7Ω		0.2		V
Line Regulation 2	$\frac{\Delta V_{REF}}{V_{REF}} / \Delta V_{CC}$	I _m = 50mA, V _{CC} = 1.8 ~ 6.0V		0.2		%/V
Temperature Characteristics	$\frac{\Delta V_a}{V_a} / \Delta T_a$	T _a = -25°C ~ +75°C		0.01		%/°C

■ Pin

Pin No.	Pin Name	Pin No.	Pin Name
1(1)	Pre-V _{REF}	13 (12)	Motor Ref. Voltage (-)
2(2)	Channel 1 Pre Amp. Input	14 (13)	Motor Ref. Voltage (+)
3(3)	Channel 1 Pre Negative Feedback	15 (14)	Comparator Input
4(4)	Channel 1 Pre Amp. Output	16	Motor V _{CC}
5(5)	Channel 1 Volume Input	17 (15)	Power V _{CC}
6(6)	Volume Control	18 (16)	Channel 2 Power Amp. Output
7(7)	Channel 1 Power Amp. Output	19 (17)	Ripple Filter
8(8)	Buffer Output	20 (18)	Channel 2 Volume Input
9(9)	Power GND	21 (19)	Channel 2 Pre Amp. Output
10	Motor GND	22 (20)	Channel 2 Pre Negative Feedback
11 (10)	Motor Terminal (-)	23 (21)	Channel 2 Pre Amp. Input
12 (11)	Phase Compensation	24 (22)	Pre GND

Note: The pin numbers in the parenthesis are for AN7082K

■ Application Circuit

(AN7082K)

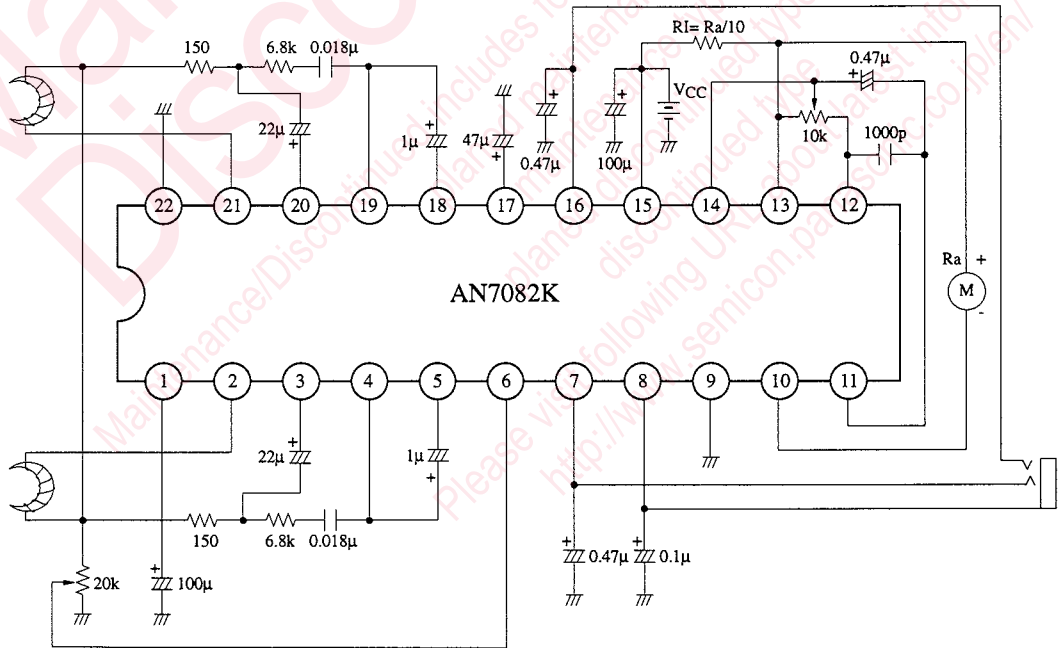

■ Application Circuit (Continue)
(AN7082S)

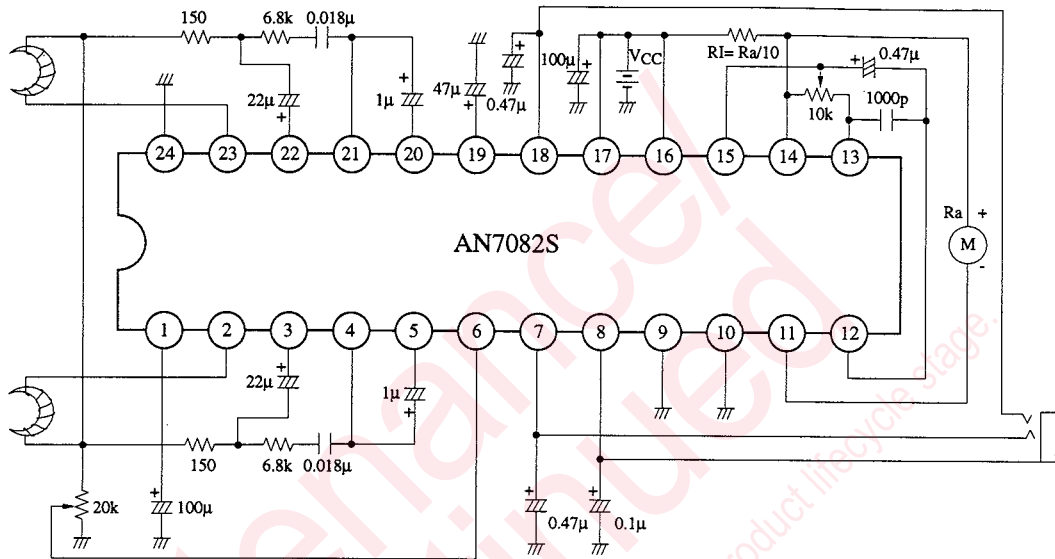

■ AN7082K Radio Application Circuit

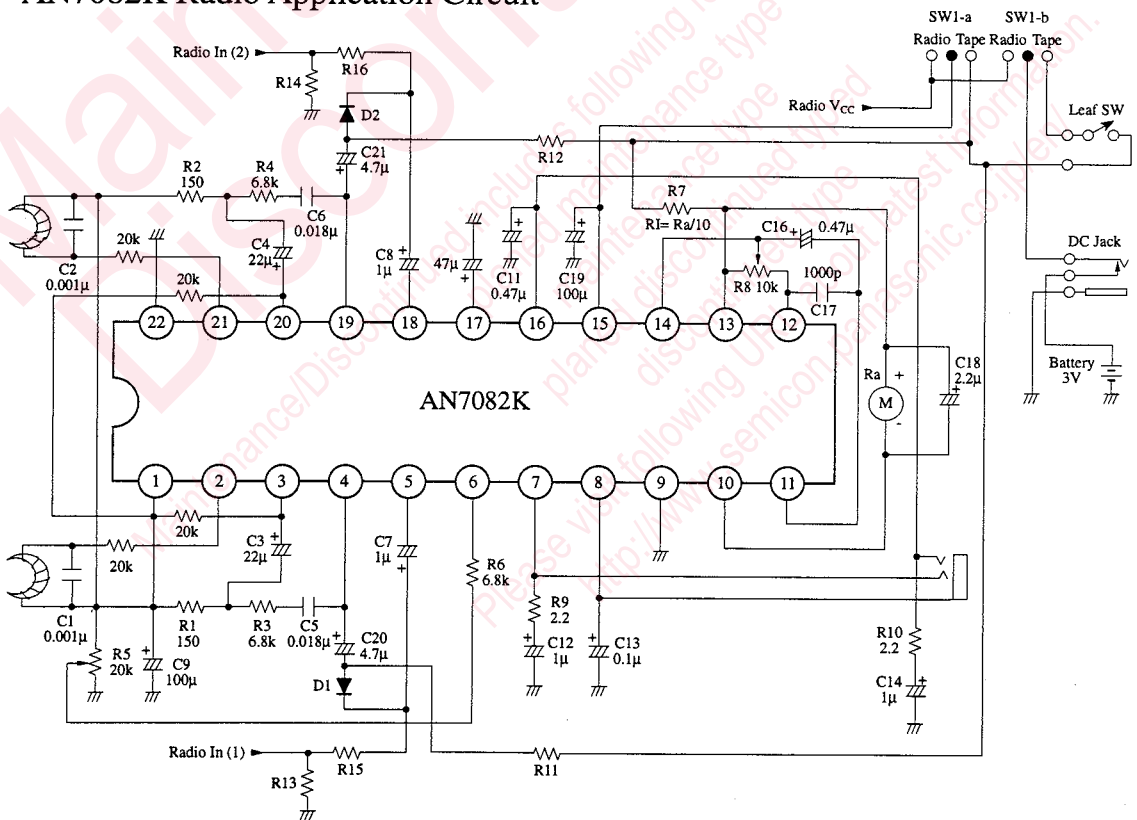

Note: Resistors R11/R12 and diodes D1/D2 are used to mute pre-amp during radio mode.
Resistor R13/R14 act as multiplexer load.
Resistors R15/R16 are used to achieve same output level during radio/playback mode.

■ Application Notes

1. Tuner Connection

- AN7082K can be combined with any tuner IC to form 2-chip Headphone stereo player. This is possible by adding 2 resistors, R11/R12 & 2 diodes, D1/D2 to function as Pre-amp Mute circuit during Radio operation.
- During Tape playback mode R11/R12 & D1/D2 are being DC biased through Tape V_{CC}, such that the Tape signal from Pre-amp output can pass through & be amplified by the subsequent power stage.
- During Radio Mode, V_{CC} supply to R11/R12 & D1/D2 is cut off, causing D1/D2 to be inoperative. As such, any Pre-amp output signals from tape will be blocked by the diodes and will not contribute to radio noise.
- Values of R11/R12 are selected to be equal to that of Tuner MPX load. Values of R13/R14 are adjusted to achieve same output power level during tape playback & radio modes.

2. Motor Hum Noise

- To reduce output noise, add C7/C8 1000p between Pre NF pins & Pre-Out pins on both channels respectively.
- Where practical, the distance between Motor and AN7082K on PCB should be kept as far as possible, especially the orientation of Pre-amp input pins. This is to reduce Motor Hum Noise feedback through to AN7082K/S inputs.

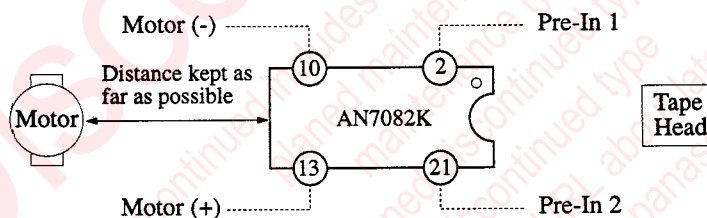

- The PCB layout tracks from pin 10 and pin 13 to Motor(-) and Motor(+) terminals should also be maintained as far as possible from Pre-amp inputs pins to reduce motor interference.
- The motor assembly is preferably covered by some metal shield to reduce noise radiation of the unit.

Request for your special attention and precautions in using the technical information and semiconductors described in this book

- (1) If any of the products or technical information described in this book is to be exported or provided to non-residents, the laws and regulations of the exporting country, especially, those with regard to security export control, must be observed.
- (2) The technical information described in this book is intended only to show the main characteristics and application circuit examples of the products. No license is granted in and to any intellectual property right or other right owned by Panasonic Corporation or any other company. Therefore, no responsibility is assumed by our company as to the infringement upon any such right owned by any other company which may arise as a result of the use of technical information described in this book.
- (3) The products described in this book are intended to be used for standard applications or general electronic equipment (such as office equipment, communications equipment, measuring instruments and household appliances).
Consult our sales staff in advance for information on the following applications:
 - Special applications (such as for airplanes, aerospace, automobiles, traffic control equipment, combustion equipment, life support systems and safety devices) in which exceptional quality and reliability are required, or if the failure or malfunction of the products may directly jeopardize life or harm the human body.
 - Any applications other than the standard applications intended.
- (4) The products and product specifications described in this book are subject to change without notice for modification and/or improvement. At the final stage of your design, purchasing, or use of the products, therefore, ask for the most up-to-date Product Standards in advance to make sure that the latest specifications satisfy your requirements.
- (5) When designing your equipment, comply with the range of absolute maximum rating and the guaranteed operating conditions (operating power supply voltage and operating environment etc.). Especially, please be careful not to exceed the range of absolute maximum rating on the transient state, such as power-on, power-off and mode-switching. Otherwise, we will not be liable for any defect which may arise later in your equipment.
 - Even when the products are used within the guaranteed values, take into the consideration of incidence of break down and failure mode, possible to occur to semiconductor products. Measures on the systems such as redundant design, arresting the spread of fire or preventing glitch are recommended in order to prevent physical injury, fire, social damages, for example, by using the products.
- (6) Comply with the instructions for use in order to prevent breakdown and characteristics change due to external factors (ESD, EOS, thermal stress and mechanical stress) at the time of handling, mounting or at customer's process. When using products for which damp-proof packing is required, satisfy the conditions, such as shelf life and the elapsed time since first opening the packages.
- (7) This book may be not reprinted or reproduced whether wholly or partially, without the prior written permission of our company.