

N-CHANNEL GaAs MES FET NE960R2 SERIES

0.2 W X, Ku-BAND POWER GaAs MES FET

DESCRIPTION

The NE960R2 Series are 0.2 W GaAs MES FETs designed for middle power transmitter applications for X, Ku-band microwave communication systems. It is capable of delivering 0.2 watt of output power (CW) with high linear gain, high efficiency and low distortion and are suitable as driver amplifiers for our X, Ku-band amplifiers etc. The NE960R200 is available in chip form. The NE960R200 has a via hole source grounding and PHS (Plated Heat Sink) for superior RF performance. The NE960R275 is available in a hermetically sealed ceramic package. Reliability and performance uniformity are assured by NEC's stringent quality and control procedures.

FEATURES

- High Output Power : P_o (1 dB) = +25.0 dBm TYP.
- High Linear Gain : 10.0 dB TYP.
- High Power Added Efficiency: 35 % TYP. @ $V_{DS} = 9$ V, $I_{Dset} = 90$ mA, $f = 14.5$ GHz

ORDERING INFORMATION

Part Number	Package	Supplying Form
NE960R200	00 (CHIP)	ESD protective envelope
NE960R275	75	

Remark To order evaluation samples, please contact your nearby sales office.

Part number for sample order: NE960R200, NE960R275

Caution Observe precautions when handling because these devices are sensitive to electrostatic discharge.

The information in this document is subject to change without notice. Before using this document, please confirm that this is the latest version.
Not all devices/types available in every country. Please check with local NEC Compound Semiconductor Devices representative for availability and additional information.

ABSOLUTE MAXIMUM RATINGS (TA = +25°C)

Operation in excess of any one of these parameters may result in permanent damage.

Parameter	Symbol	Ratings	Unit
Drain to Source Voltage	V _{DS}	15	V
Gate to Source Voltage	V _{GSO}	-7	V
Drain Current	I _D	0.35	A
Gate Forward Current	I _{GF}	+2.5	mA
Gate Reverse Current	I _{GR}	-2.5	mA
★ Total Power Dissipation	P _T	2.5	W
Channel Temperature	T _{ch}	175	°C
Storage Temperature	T _{stg}	-65 to +175	°C

RECOMMENDED OPERATING CONDITIONS

Parameter	Symbol	Test Condition	MIN.	TYP.	MAX.	Unit
Drain to Source Voltage	V _{DS}		-	9.0	9.0	V
Gain Compression	G _{comp}		-	-	3.0	dB
Channel Temperature	T _{ch}		-	-	+130	°C

ELECTRICAL CHARACTERISTICS

(TA = +25°C, unless otherwise specified, using NEC standard test fixture.)

Parameter	Symbol	Test Conditions	MIN.	TYP.	MAX.	Unit
Saturated Drain Current	I _{DSS}	V _{DS} = 1.5 V, V _{GS} = 0 V	0.09	0.2	0.35	A
Pinch-off Voltage	V _p	V _{DS} = 2.5 V, I _D = 1 mA	-2.5	-1.8	-0.5	V
Gate to Drain Break Down Voltage	BV _{gd}	I _{gd} = 1 mA	15	-	-	V
★ Thermal Resistance	R _{th}	Channel to Case	-	-	60	°C/W
Output Power at P _{in} = +15 dBm	P _{out}	f = 14.5 GHz, V _{DS} = 9.0 V R _g = 1 kΩ I _{Dset} = 90 mA (RF OFF)	22.0	24.0	-	dBm
Output Power at 1 dB Gain Compression Point	P _{O(1dB)}		-	25.0	-	dBm
Power Added Efficiency at P _{O(1dB)}	η _{add}		-	35	-	%
Linear Gain	G _L		8.0	10.0	-	dB

Remark DC and RF performance is 100 % testing.

TYPICAL CHARACTERISTICS (T_A = +25°C)

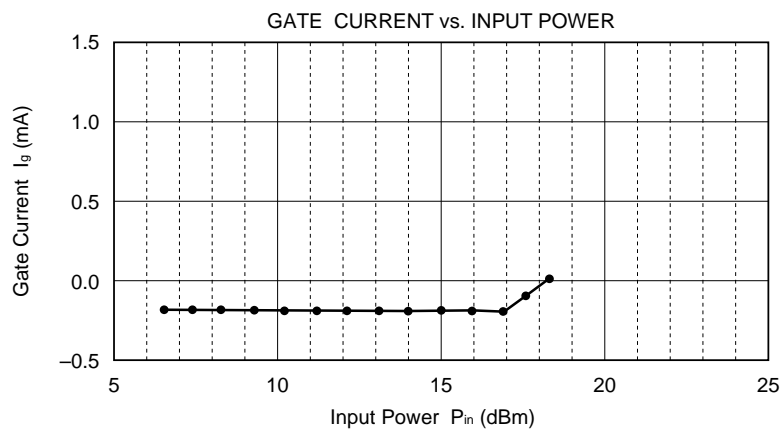
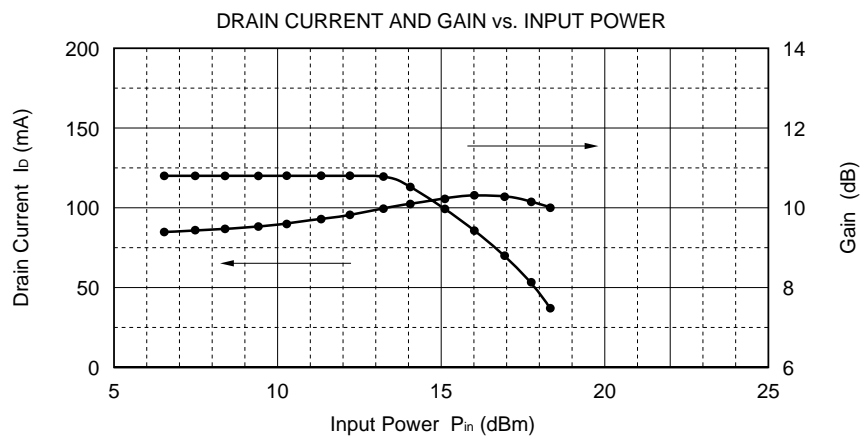
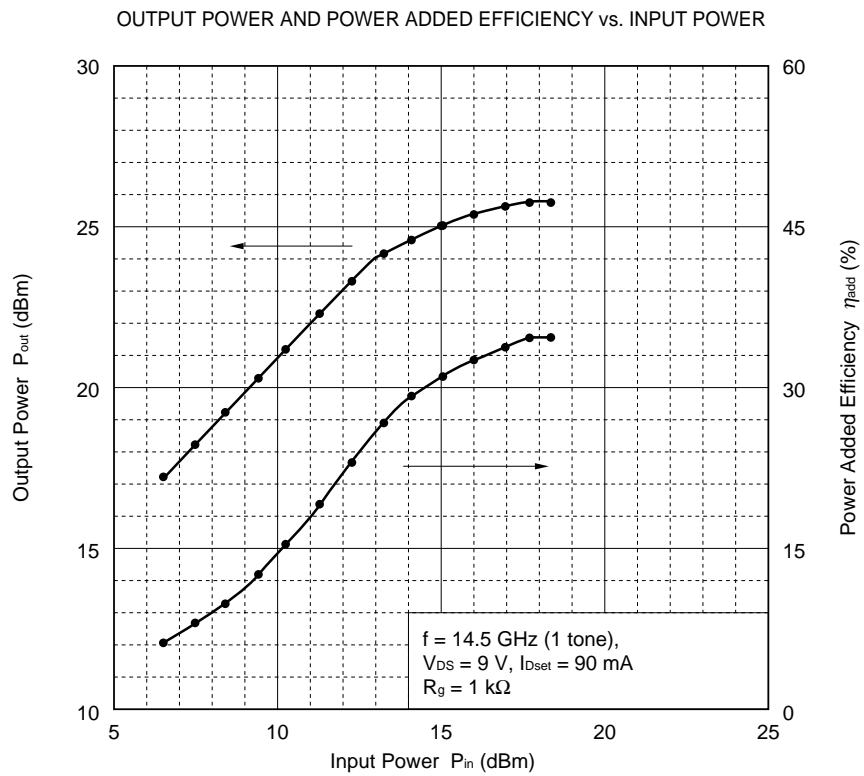

Remark The graphs indicate nominal characteristics.

S-PARAMETERS

S-parameters/Noise parameters are provided on the NEC Compound Semiconductor Devices Web site in a form (S2P) that enables direct import to a microwave circuit simulator without keyboard input.

Click here to download S-parameters.

[RF and Microwave] → [Device Parameters]

URL <http://www.ncsd.necel.com/>

PACKAGE DIMENSIONS

PACKAGE CODE-75 (Unit: mm)

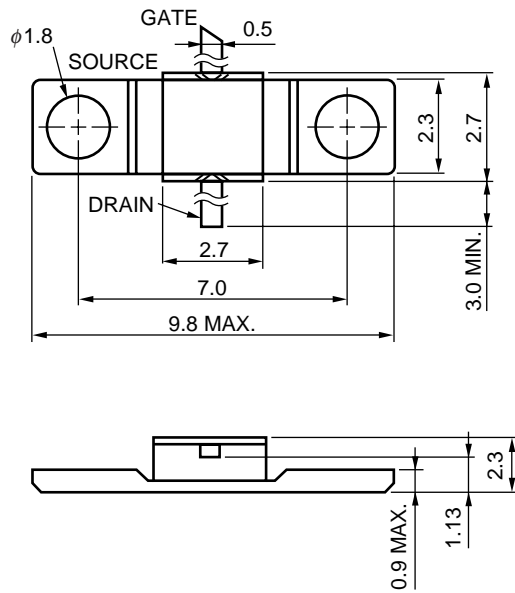

★ PHYSICAL DIMENSIONS

NE960R200 (CHIP) (Unit: μm)

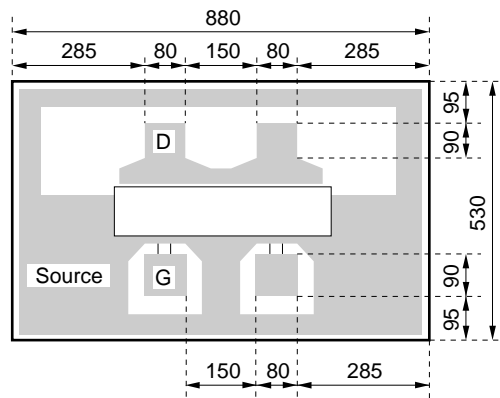

Remark Chip thickness: 100 μm

G : Gate

D : Drain

★ **RECOMMENDED SOLDERING CONDITIONS**

This product should be soldered under the following recommended conditions. For soldering methods and conditions other than those recommended below, contact your nearby sales office.

Soldering Method	Soldering Conditions	Condition Symbol
Partial Heating	Peak temperature (pin temperature) : 350°C or below Soldering time (per pin of device) : 3 seconds or less Maximum chlorine content of rosin flux (% mass) : 0.2 % (Wt.) or below	HS350-P3

Caution Do not use different soldering methods together (except for partial heating).

CHIP HANDLING

DIE ATTACHMENT

Die attach can be accomplished with a Au-Sn (300 ±10°C) performs in a forming gas environment. Epoxy die attach is not recommended.

BONDING

Gate and drain bonding wires should be minimum length, semi-hard gold wire (3 to 8 % elongation) 30 microns or less in diameter.

Bonding should be performed with a wedge tip that has a taper of approximately 15 %.

Die attach and bonding time should be kept to a minimum. As a general rule, the bonding operation should be kept within a 280°C_5 minute curve. If longer periods are required, the temperature should be lowered.

PRECAUTIONS

The user must operate in a clean, dry environment.

The chip channel is glassivated for mechanical protection only and does not preclude the necessity of a clean environment.

The bonding equipment should be periodically checked for sources of surge voltage and should be properly grounded at all times. In fact, all test and handling equipment should be grounded to minimize the possibilities of static discharge.

- **The information in this document is current as of August, 2003. The information is subject to change without notice. For actual design-in, refer to the latest publications of NEC's data sheets or data books, etc., for the most up-to-date specifications of NEC semiconductor products. Not all products and/or types are available in every country. Please check with an NEC sales representative for availability and additional information.**
 - No part of this document may be copied or reproduced in any form or by any means without prior written consent of NEC. NEC assumes no responsibility for any errors that may appear in this document.
 - NEC does not assume any liability for infringement of patents, copyrights or other intellectual property rights of third parties by or arising from the use of NEC semiconductor products listed in this document or any other liability arising from the use of such products. No license, express, implied or otherwise, is granted under any patents, copyrights or other intellectual property rights of NEC or others.
 - Descriptions of circuits, software and other related information in this document are provided for illustrative purposes in semiconductor product operation and application examples. The incorporation of these circuits, software and information in the design of customer's equipment shall be done under the full responsibility of customer. NEC assumes no responsibility for any losses incurred by customers or third parties arising from the use of these circuits, software and information.
 - While NEC endeavours to enhance the quality, reliability and safety of NEC semiconductor products, customers agree and acknowledge that the possibility of defects thereof cannot be eliminated entirely. To minimize risks of damage to property or injury (including death) to persons arising from defects in NEC semiconductor products, customers must incorporate sufficient safety measures in their design, such as redundancy, fire-containment, and anti-failure features.
 - NEC semiconductor products are classified into the following three quality grades:
 "Standard", "Special" and "Specific". The "Specific" quality grade applies only to semiconductor products developed based on a customer-designated "quality assurance program" for a specific application. The recommended applications of a semiconductor product depend on its quality grade, as indicated below. Customers must check the quality grade of each semiconductor product before using it in a particular application.
 "Standard": Computers, office equipment, communications equipment, test and measurement equipment, audio and visual equipment, home electronic appliances, machine tools, personal electronic equipment and industrial robots
 "Special": Transportation equipment (automobiles, trains, ships, etc.), traffic control systems, anti-disaster systems, anti-crime systems, safety equipment and medical equipment (not specifically designed for life support)
 "Specific": Aircraft, aerospace equipment, submersible repeaters, nuclear reactor control systems, life support systems and medical equipment for life support, etc.
- The quality grade of NEC semiconductor products is "Standard" unless otherwise expressly specified in NEC's data sheets or data books, etc. If customers wish to use NEC semiconductor products in applications not intended by NEC, they must contact an NEC sales representative in advance to determine NEC's willingness to support a given application.
- (Note)
- (1) "NEC" as used in this statement means NEC Corporation, NEC Compound Semiconductor Devices, Ltd. and also includes its majority-owned subsidiaries.
 - (2) "NEC semiconductor products" means any semiconductor product developed or manufactured by or for NEC (as defined above).

M8E 00.4-0110

<p>Caution</p>	<p>GaAs Products</p>	<p>This product uses gallium arsenide (GaAs). GaAs vapor and powder are hazardous to human health if inhaled or ingested, so please observe the following points.</p> <ul style="list-style-type: none"> • Follow related laws and ordinances when disposing of the product. If there are no applicable laws and/or ordinances, dispose of the product as recommended below. <ol style="list-style-type: none"> 1. Commission a disposal company able to (with a license to) collect, transport and dispose of materials that contain arsenic and other such industrial waste materials. 2. Exclude the product from general industrial waste and household garbage, and ensure that the product is controlled (as industrial waste subject to special control) up until final disposal. • Do not burn, destroy, cut, crush, or chemically dissolve the product. • Do not lick the product or in any way allow it to enter the mouth.
-----------------------	----------------------	---

► For further information, please contact

NEC Compound Semiconductor Devices, Ltd. <http://www.ncsd.necel.com/>

E-mail: salesinfo@csd-nec.com (sales and general)

techinfo@csd-nec.com (technical)

5th Sales Group, Sales Division TEL: +81-44-435-1588 FAX: +81-44-435-1579

NEC Compound Semiconductor Devices Hong Kong Limited

E-mail: ncsd-hk@elhk.nec.com.hk (sales, technical and general)

Hong Kong Head Office TEL: +852-3107-7303 FAX: +852-3107-7309

Taipei Branch Office TEL: +886-2-8712-0478 FAX: +886-2-2545-3859

Korea Branch Office TEL: +82-2-558-2120 FAX: +82-2-558-5209

NEC Electronics (Europe) GmbH <http://www.ee.nec.de/>

TEL: +49-211-6503-01 FAX: +49-211-6503-487

California Eastern Laboratories, Inc. <http://www.cel.com/>

TEL: +1-408-988-3500 FAX: +1-408-988-0279