



FDDI / Fast Ethernet PHYceiver™

General Description

The ICS1887 is designed to provide high performance clock recovery and generation for 125 MHz serial data streams. The ICS1887 is ideally suited for LAN transceiver applications in either FDDI or Fast Ethernet environments. The ICS1887 converts NRZ to/from NRZI data in addition to providing a 5-bit parallel digital data transmit and receive interface.

Clock and data recovery is performed on an input serial data stream or the buffered transmit data depending upon the state of the loopback input. A continuous clock source will continue to be present even in the absence of input data. All internal timing is derived from either a low cost crystal, differential or single-ended source.

The ICS1887 utilizes advanced CMOS phase-locked loop technology which combines high performance and low power at a greatly reduced cost.

Features

- Single IC solution to existing designs requiring multiple devices
- Data and clock recovery for 125 MBaud FDDI or Fast Ethernet applications
- Clock multiplication from either a crystal, differential or single-ended timing source
- Continuous clock in the absence of data
- No external PLL components
- Lock/Loss status indicator output
- Loopback mode for system diagnostics
- Selectable loop timing mode
- PECL driver with settable sink current
- Parallel digital transmit and receive data interface
- NRZ to/from NRZI data conversion
- Consult ICS for optional configurations and data rates

Block Diagram

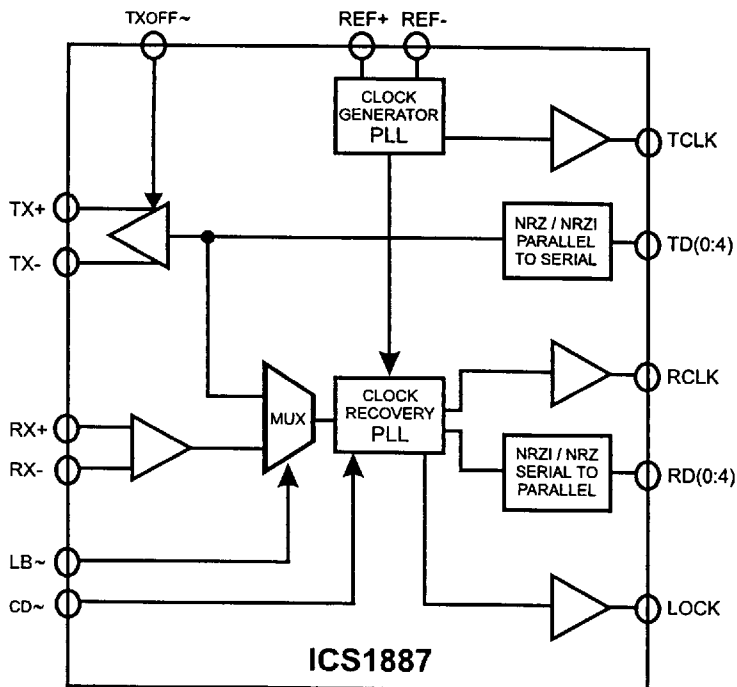

Pin Configuration

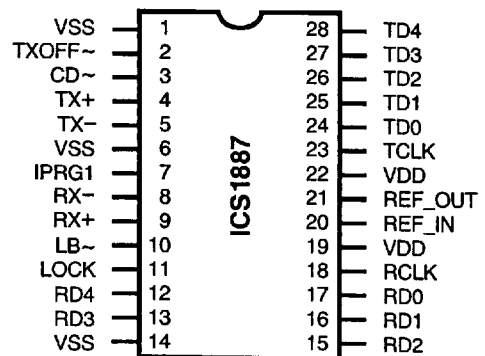

28-Pin SOIC



Pin Descriptions

PIN NUMBER	PIN NAME	TYPE	DESCRIPTION
1	VSS		Negative Supply Voltage
2	TXOFF~ ²	TTL-Compatible	Transmitter Off*
3	CD~	TTL-Compatible ¹	Carrier Detect input*
4	TX+	PECL	Positive Transmit serial data output
5	TX-	PECL	Negative Transmit serial data output
6	VSS		Negative supply voltage
7	IPRG1		PECL Output stage current set (TX)
8	RX-	PECL	Negative Receive serial data input
9	RX+	PECL	Positive Receive serial data input
10	LB~	TTL-Compatible	Loop Back mode select*
11	LOCK	TTL-Compatible	Lock detect output
12	RD4	TTL-Compatible	Recovered data output 4
13	RD3	TTL-Compatible	Recovered data output 3
14	VSS		Negative supply voltage
15	RD2	TTL-Compatible	Recovered data output 2
16	RD1	TTL-Compatible	Recovered data output 1
17	RD0	TTL-Compatible	Recovered data output 0
18	RCLK	TTL-Compatible	Recovered Receive clock output
19	VDD		Positive supply voltage
20	REF_IN		Positive reference clock/crystal input
21	REF_OUT		Negative reference clock/crystal output
22	VDD		Positive supply voltage
23	TCLK	TTL-Compatible	Transmit clock output
24	TD0	TTL-Compatible	Transmit data input 0
25	TD1	TTL-Compatible	Transmit data input 1
26	TD2	TTL-Compatible	Transmit data input 2
27	TD3	TTL-Compatible	Transmit data input 3
28	TD4	TTL-Compatible	Transmit data input 4

* Active Low Input.

Note:

1. A running production change will be made to this input in the June 1996 time frame to convert this input from the TTL-compatible to PECL to more closely match applications requirements. See *Substituting the ICS1887 for the AMD PDR & PDT* applications note for more information.
2. This pin was formerly used for Loop-Timed operation. If your design did not use loop timing, this change does not affect you. If your application requires loop timing, please contact ICS.



Input Pin Descriptions

Parallel Transmit Data (TD0 .. TD4)

Five bit TTL compatible digital input, which is received by the ICS1887 on the positive edge of TCLK. High impedance input drivers routed to the serial NRZ to NRZI converter. In loopback testing mode, this NRZI data is multiplexed to the input of the device clock recovery section.

Differential ECL Receive Data Input (RX+ & RX-)

The clock recovery and data regenerator from the receive buffer are driven from this PECL input. During loopback testing mode this input is ignored.

Carrier Detect (CD~)

Active low input which forces the VCO to free run. Upon receipt of a loss of input signal (such as from an optical-to-electrical transducer), the internal phase-lock loop will free-run at the selected operating frequency. Also, when asserted, CD will set the lock output low.

Transmitter Off (TXOFF~)

Active low input which, when low, forces TX+ low and TX-high. When high, data passes through TX+ and TX- unaffected. This input has an internal pull-up resistor.

Loopback Mode (LB~)

Active low input which causes the clock recovery PLL to operate using the transmit input data reference and ignore the receive RX± data. Utilized for system loopback testing.

External Crystal or Reference Clock (REF_IN and REF_OUT)

This oscillator input can be driven from either a fundamental mode crystal or a stable reference. For either method, the reference frequency is 25.00 MHz.

Output Pin Descriptions

Differential ECL Transmit Data (TX+ and TX-)

This differential output is converted TD[0..4] serial data. This output remains active during loopback mode.

Transmit Clock (TCLK)

TTL compatible 25 MHz clock used by the parallel processor transmitter for clocking out transmit data. This clock can be derived from either an independent clock source or from the recovered data clock (system loop time mode).

Parallel Receive Data (RD0 .. RD4)

The regenerated five bit parallel data derived from the serial data input. In loopback mode this data is regenerated from the transmit data. This data is phase-aligned with the negative edge of RCLK clock output.

Receive Clock (RCLK)

A 25 MHz digital clock recovered with the internal clock recovery PLL. In loopback mode this clock is recovered from the transmit data.

Lock/Loss Detect (LOCK)

Set high when the clock recovery PLL has locked onto the incoming data. Set low when there is no incoming data, which in turn causes the PLL to free-run. This signal can be used to indicate or 'alarm' the next receive stage that the incoming serial data has stopped.

Output Description

The differential driver for the TX± is current mode and is designed to drive resistive terminations in a complementary fashion. The output is current-sinking only, with the amount of sink current programmable via the IPRG1 pin. The sink current is equal to four times the IPRG1 current. For most applications, an 910Ω resistor from VDD to IPRG1 will set the current to the necessary precision.

The TX± pins are incapable of sourcing current, so VOH must be set by the ratios of the Thevenin termination resistors for each of these lines. R1 is a pull-up resistor connected from the PECL output to VDD. R2 is a pull-down resistor connected from the PECL output to VSS. R1 and R2 are electrically in parallel from an AC standpoint. If we pick a target impedance of 50Ω for our transmission line impedance, a value of 62Ω for R1 and a value of 300Ω for R2 would yield a Thevinin equivalent characteristic impedance of 50Ω and a VOH value of VDD - .88 volts, compatible with PECL circuits.

To set a value for VOL, we must determine a value for Iprg that will cause the output FET's to sink an appropriate current. We desire VOL to be VDD - 1.81 or greater. Setting up a sink current of 19 milliamperes would guarantee this through our output terminating resistors. As this is controlled by a 4/1 current mirror, 4.75 mA into Iprg should set this current properly. An 910Ω resistor from VDD to Iprg should work fine.

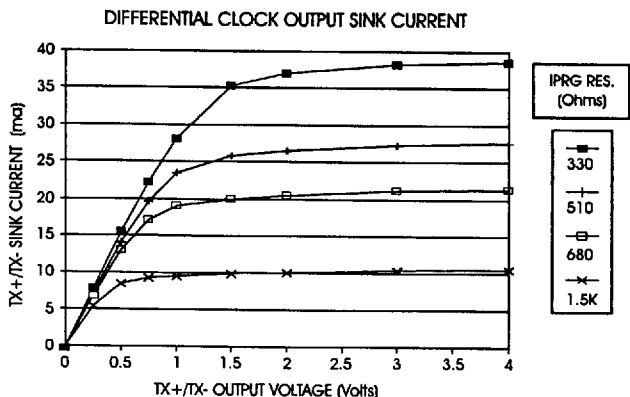

ICS1887



ICS1887 System Diagram (PECL Termination for 50Ω Transmission Lines)

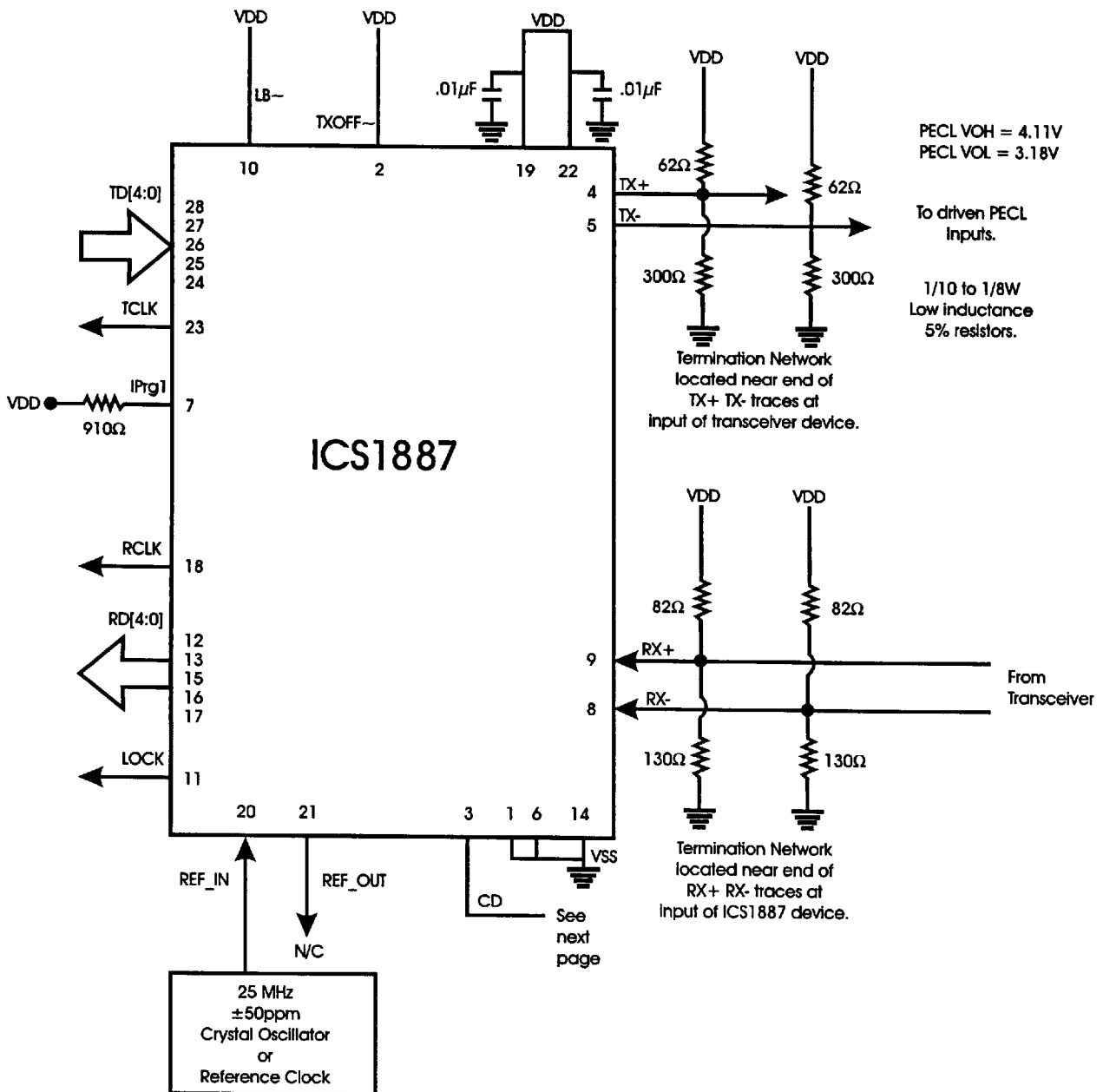



Substituting the ICS1887 for the AMD PDR & PDT

This note describes the issues involved in replacing the AMD PDR & PDT with the ICS1887.

There are a number of implementation differences between AMD's PDR & PDT and the ICS1887. This note describes the differences and how they affect an application.

Signal Detect

Many twisted pair and fiber optic transceivers provide a signal detect indication that becomes active when the amount of energy being received reaches a threshold that makes it appear to be data and not ambient noise.

The AMD PDR device has a single ended PECL input (SDI) and provides a TTL level output (SDO) that tracks the input. The input controls the source that the PLL locks to. When signal detect is asserted, the PLL locks to the incoming receive data. When signal detect is deasserted, the PLL locks to the LSCLK input to prevent locking to an off center frequency.

The current ICS1887 device provides a single TTL-compatible input, carrier detect (CD~). When carrier detect is asserted, the ICS1887 locks to the incoming receive data. When carrier detect is deasserted, or if carrier detect is asserted and no data is present on the receive inputs, the PLL will free run and continue to provide RXCLK at the nominal 25 MHz frequency. This allows the carrier detect input to always be tied to an asserted level (ground).

If a true signal detect is required by a chip that connects to the ICS1887, a simple, low cost PECL to CMOS converter can be used. The following circuit implements this function:

CD PECL Input: Board Layout Options

Option 1

Differential PECL to CMOS Conversion Circuit

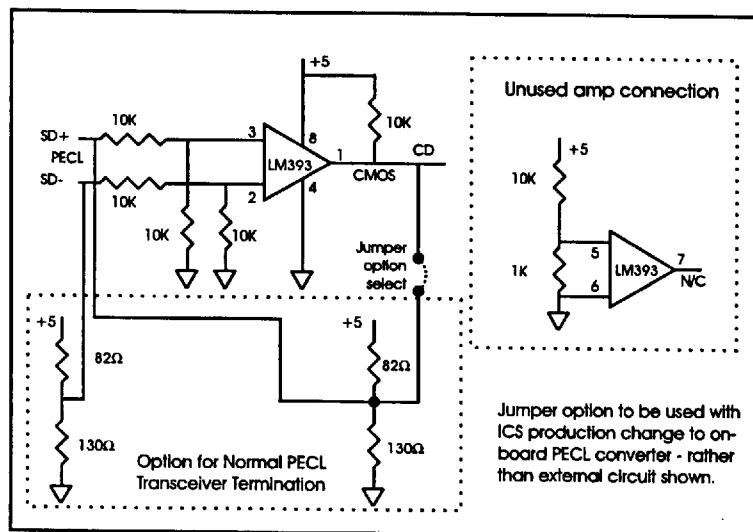

Option 2

Single-Ended PECL to CMOS Conversion Circuit

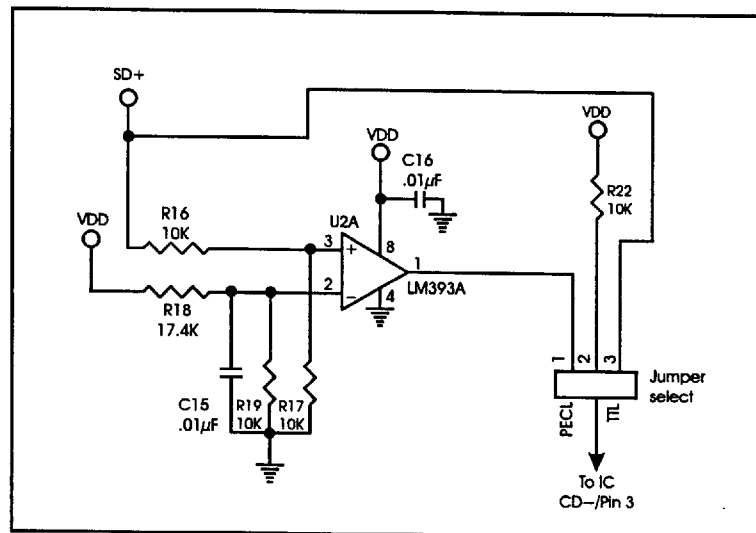



This circuit provides the PECL to CMOS conversion for less than \$0.80 in single unit quantities. Note that the LM393 has two amplifiers, so the unused one is tied inactive.

A running production change will be made to the ICS1887 to change the CD input to PECL. Therefore, boards should be laid out with a direct normal PECL termination connection stuffing option. This allows either version of the part to be used by stuffing one of two sets of external components. A version of this circuit is shown in the diagram on the previous page.

With ICS1887 devices that have a TTL-compatible CD input, the "Differential PECL to CMOS Conversion Circuit" components need to be placed on the PCB and the "Normal PECL Transceiver Termination" resistors (82Ω and 130Ω) as well as the option select jumper should NOT be placed.

When the final ICS1887 device with the PECL CD input is used, none of the components in the "Differential PECL to CMOS Conversion Circuit" or the "Unused amp connection" circuits should be used. Only the four termination resistors (87Ω and 130Ω) and the option select jumper are needed. Note that these resistors should be located near the ends of the transmission lines.

Clocking

Parallel data that is to be serialized for transmission must be presented to the data transmitter device with a certain amount of setup and hold time to a given clock.

The PDT chip expects data to setup relative to the 25 MHz Local Symbol Clock (LSCLK). This clock is an input to the device.

The ICS1887 expects data to be setup relative to the 25 MHz Reference In Clock (REF_IN). This clock is an input to the ICS1887 device. Note that the REF_IN pin of the ICS1887 is a CMOS input with a switching point of 50% of VDD. If this pin is driven by a TTL output, a pull-up resistor to VDD must be used. The ICS1887 device also provides a Transmit Clock (TXC) output, which is a 50% duty cycle (nominal) copy of the REF_IN input. The ICS1887 is designed to provide a very low skew between the REF_IN and the TXC.

Loopback

The AMD PDR & PDT chips have an external loopback connection between the two chips. The ICS1887 also has a loopback function, but it is totally internal to the device.

Optical Transmitter Off Control

The PDT chip has an input (FOTOFF) which can force an optical transceiver to be off. The ICS1887 performs the same behavior with the TXOFF~ pin.

Test Mode

Both the AMD PDR & PDT have a test mode that allows automated testers to test internal logic without the PLL clock multiplier. The ICS1887 does not have a similar test mode.

Transmit Current Selection

The ICS1887 allows the PECL transmit current level to be set externally. An 887Ω resistor to the VDD supply is recommended.



Absolute Maximum Ratings

- V_{DD} (measured to V_{SS}) 7.0V
- Digital Inputs/Outputs V_{SS} - 0.5V to V_{DD} + 0.5V
- Ambient Operating Temperature -55°C to +125°C
- Storage Temperature -65°C to +150°C
- Junction Temperature 175°C
- Soldering Temperature 260°C

Stresses above those listed under *Absolute Maximum Ratings* above may cause permanent damage to the device. This is a stress rating only and functional operation of the device at these or any other conditions above those listed in the operational section of the specifications is not implied. Exposure to absolute maximum rating conditions for extended periods may affect product reliability.

Recommended Operating Conditions

PARAMETER	SYMBOL	TEST CONDITIONS	MIN	MAX	UNITS
Ambient Operating Temp.	T _A		0	+70	°C
Using a Positive Supply	V _{SS}		0.0	0.0	V
	V _{DD}		+4.50	+5.50	V

ICS1887 FDDI / Fast Ethernet Application

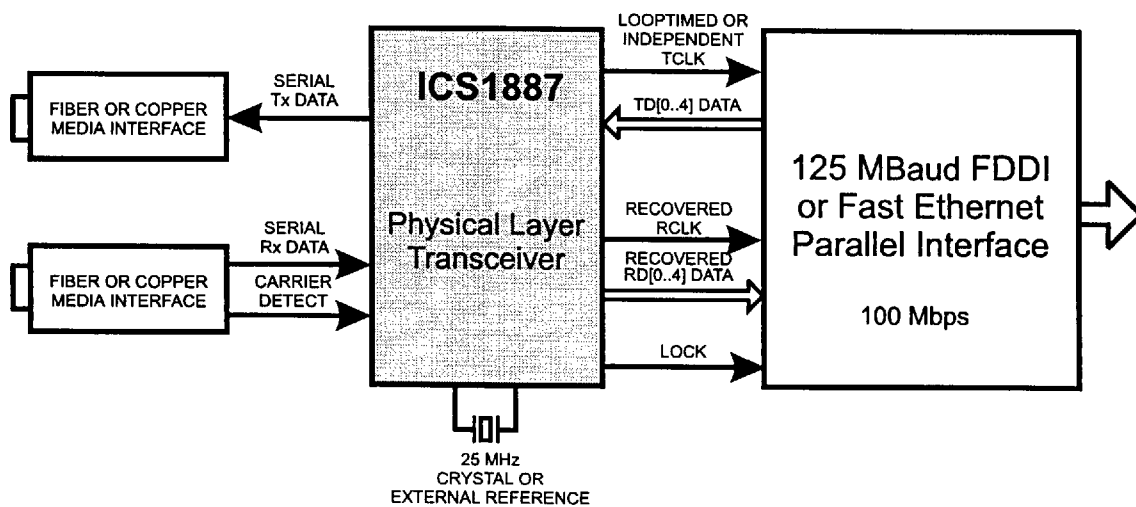



DC Characteristics

$V_{DD} = V_{MIN}$ to V_{MAX} , $V_{SS} = 0V$, $T_A = T_{MIN}$ to T_{MAX}

PARAMETER	SYMBOL	CONDITIONS	MIN	MAX	UNITS
Supply Current	I_{DD}	$V_{DD} = +5.0V$, $V_{SS} = 0.0V$	—	80	mA
ECL Input / Output					
PARAMETER	SYMBOL	CONDITIONS	MIN	MAX	UNITS
ECL Input High Voltage	V_{IH}		$V_{DD} - 1.16$	$V_{DD} - 0.88$	V
ECL Input Low Voltage	V_{IL}		$V_{DD} - 1.81$	$V_{DD} - 1.47$	V
ECL Differential Threshold Voltage Range	V_{TH}		—	150	mV
ECL Input Common Mode Voltage	V_{CM}		1.3	$V_{DD} - .4$	V
ECL Output High Voltage	V_{OH}		$V_{DD} - 1.02$	—	V
ECL Output Low Voltage	V_{OL}		—	$V_{DD} - 1.62$	V
TTL Input / Output					
PARAMETER	SYMBOL	CONDITIONS	MIN	MAX	UNITS
TTL Input High Voltage	V_{IH}	$V_{DD} = 5.0V$, $V_{SS} = 0.0V$	2.0	—	V
TTL Input Low Voltage	V_{IL}	$V_{DD} = 5.0V$, $V_{SS} = 0.0V$	—	0.8	V
TTL Output High Voltage	V_{OH}	$V_{DD} = 5.0V$, $V_{SS} = 0.0V$	2.4	—	V
TTL Output Low Voltage	V_{OL}	$V_{DD} = 5.0V$, $V_{SS} = 0.0V$	—	0.4	V
TTL Driving CMOS Output High Voltage	V_{OH}	$V_{DD} = 5.0V$, $V_{SS} = 0.0V$	3.68	—	V
TTL Driving CMOS Output Low Voltage	V_{OL}	$V_{DD} = 5.0V$, $V_{SS} = 0.0V$	—	0.4	V
TTL / CMOS Output Sink Current	I_{OL}	$V_{DD} = 5.0V$, $V_{SS} = 0.0V$	8	—	mA
TTL / CMOS Output Source Current	I_{OH}	$V_{DD} = 5.0V$, $V_{SS} = 0.0V$	—	-0.4	mA
REF_IN Input					
PARAMETER	SYMBOL	CONDITIONS	MIN	MAX	UNITS
Input High Voltage	V_{IH}	$V_{DD} = 5.0V$, $V_{SS} = 0.0V$	3.5	—	V
Input Low Voltage	V_{IL}	$V_{DD} = 5.0V$, $V_{SS} = 0.0V$	—	1.5	V

Note: REF_IN Input switch point is 50% of VDD.



AC Characteristics

Clocks – Reference In (REF_IN) to Transmit Clock (TCLK)

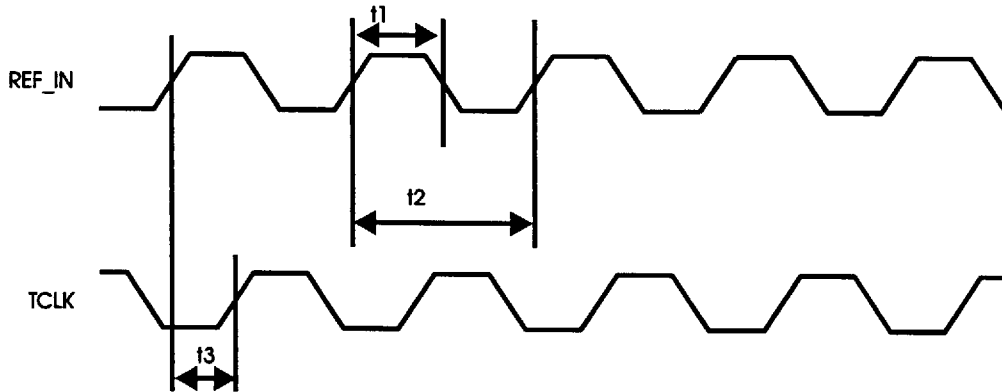

T#	PARAMETER (conditions)	MIN	TYP	MAX	UNITS
t1	REF_IN Duty Cycle	45	50	55	%
t2	REF_IN Period	—	40	—	ns
t3	REF_IN rise to TCLK rise	0	1.5	3.0	ns



Clocks — Transmit Clock Tolerance

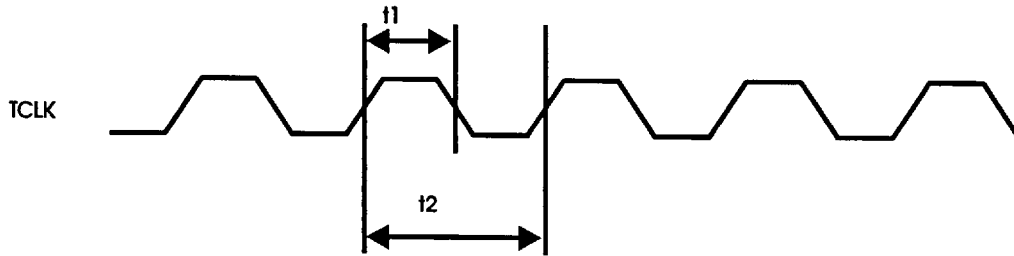

T#	PARAMETER (conditions)	MIN	TYP	MAX	UNITS
t1	TCLK Duty Cycle	40	50	60	%
t2	TCLK Period	—	40	—	ns

Note: TCLK Duty cycle = REF_IN Duty cycle ±5%.

Clocks — Receive Clock Tolerance

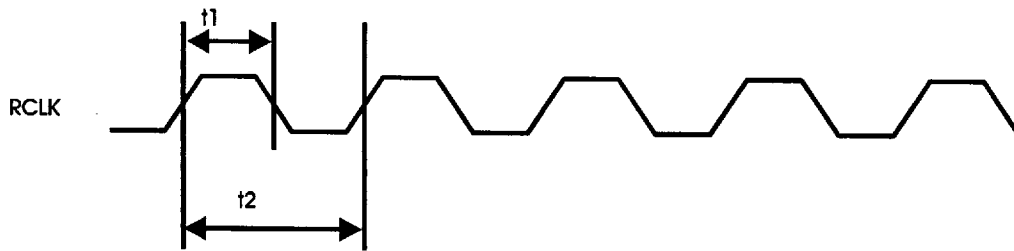

T#	PARAMETER (conditions)	MIN	TYP	MAX	UNITS
t1	RCLK Duty Cycle	45	50	55	%
t2	RCLK Period	—	40	—	ns



5-Bit Interface – Synchronous Transmit Timing

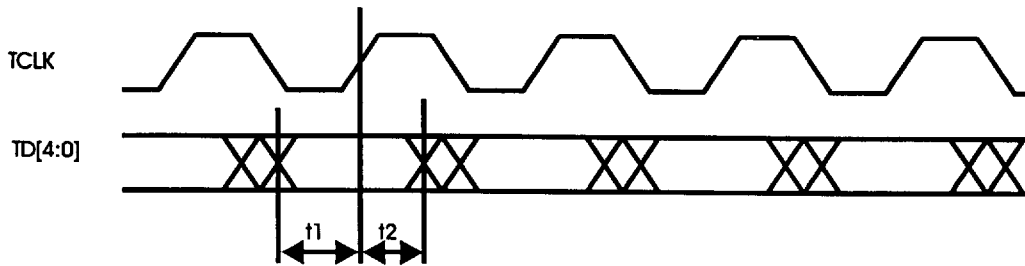

T#	PARAMETER (conditions)	MIN	TYP	MAX	UNITS
t1	TD[4:0] Setup to TCLK rise	10	—	—	ns
t2	TD[4:0] Hold after TCLK rise	0	—	—	ns

5-Bit Interface – Synchronous Receive Timing

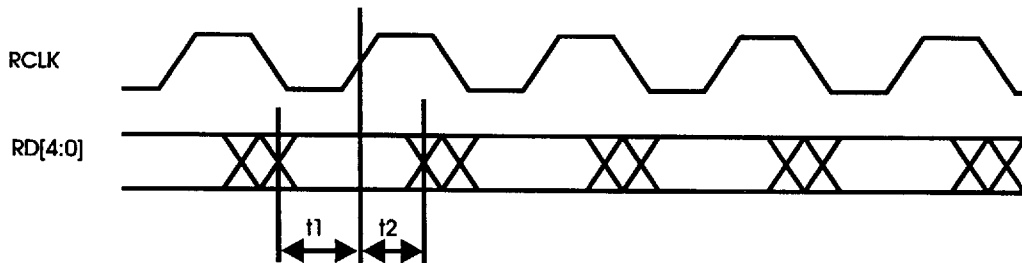

T#	PARAMETER (conditions)	MIN	TYP	MAX	UNITS
t1	RD[4:0] Setup to RCLK rise	13.0	—	—	ns
t2	RD[4:0] Hold after RCLK rise	12.5	—	—	ns



Transmit Latency

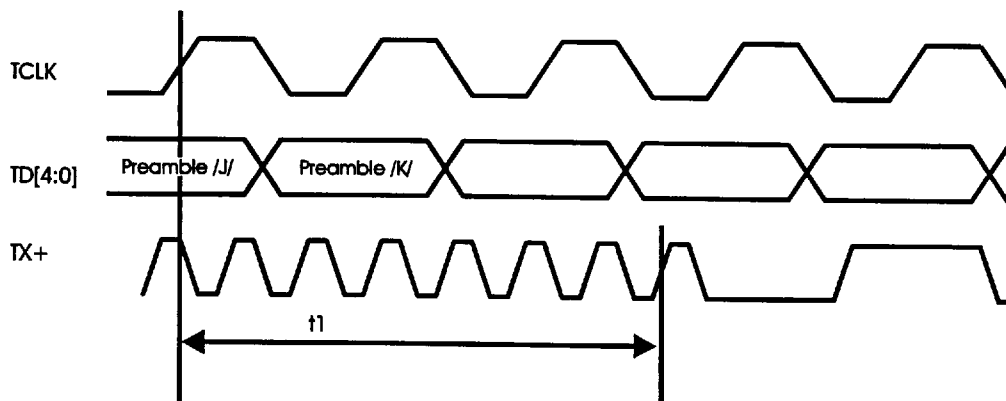

T#	PARAMETER (conditions)	MIN	TYP	MAX	UNITS
t1	TD[4:0] sampled to TX+ Output of 1st bit	—	—	5	bits

Receive Latency

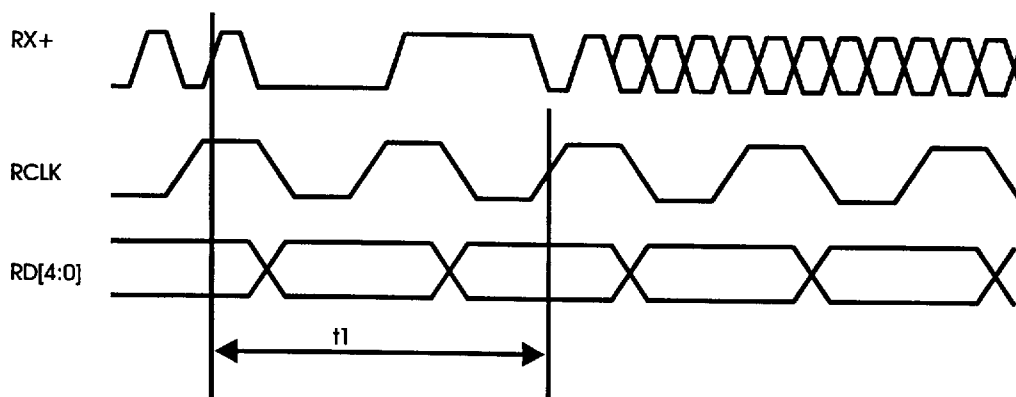

T#	PARAMETER (conditions)	MIN	TYP	MAX	UNITS
t1	MSbit into RX+ to MSb on RD[4:0]	—	—	8	bits



Clock Recovery

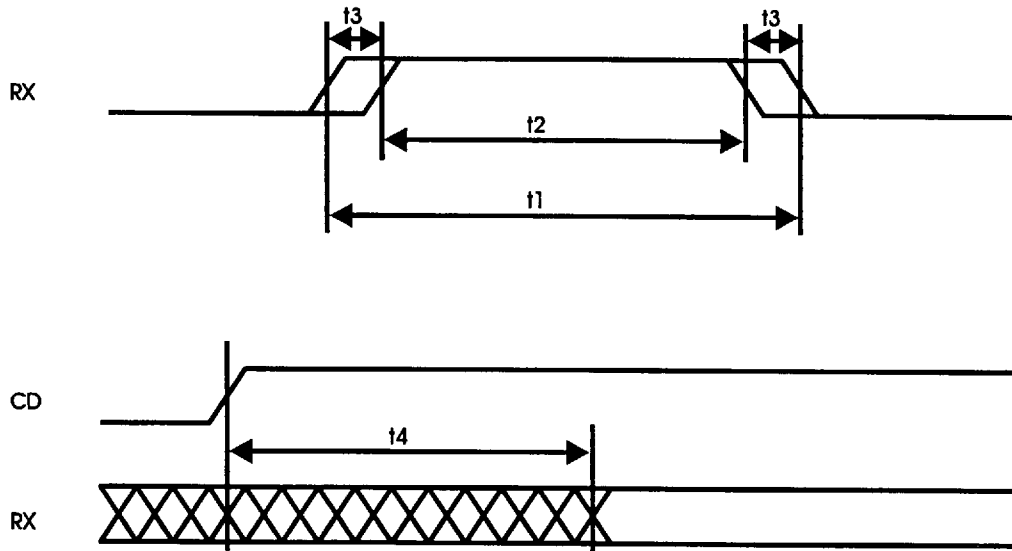

T#	PARAMETER (conditions)	MIN	TYP	MAX	UNITS
t1	Ideal data recovery window	—	—	8	ns
t2	Actual data recovery window	6	—	8	ns
t3	Data recovery window truncation	0	—	1	ns
t4	CD assert to data acquired	—	—	5	μ

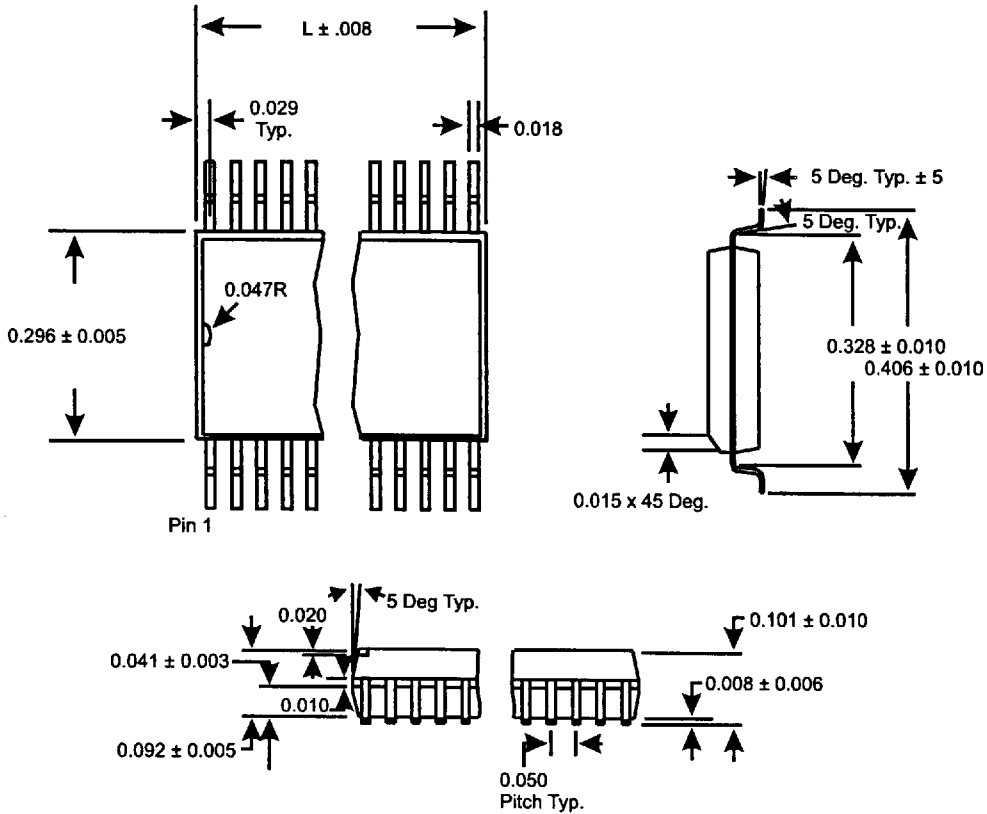

SOIC PACKAGE

LEAD COUNT	28L
DIMENSION L	0.704

Ordering Information

ICS1887M

Example:

ICS XXXX M

