

MINI ANALOG SERIES CMOS COMPARATOR

S-89210A/89220A

The mini-analog series is a group of ICs that incorporate a general purpose analog circuit in a small package.

The S-89210A/89220A is a CMOS type comparator that has a phase compensation circuit, and that can be driven at a lower voltage with lower current consumption than existing bipolar comparators. These features make this product the ideal solution for small battery-powered portable equipment. The S-89210A/89220A is a single comparator.

■ Features

- Lower operating voltage than the conventional general-purpose comparators: $V_{DD} = 1.8$ to 5.5 V
- Low current consumption: $I_{DD} = 50$ μ A (S-89210A)
 $I_{DD} = 10$ μ A (S-89220A)
- Low input offset voltage: 4.0 mV (max.)

■ Application

- Cellular phones
- PDAs
- Notebook PCs
- Digital cameras
- Digital video cameras

■ Package

Package Name	Drawing Code		
	Package	Tape	Reel
SC-88A	NP005-B	NP005-B	NP005-B

■ Product Code List

Table 1

Current consumption	SC-88A
$I_{DD} = 50$ μ A	S-89210ACNC-1C0-TF
$I_{DD} = 10$ μ A	S-89220ACNC-1C1-TF

Remark Delivery form : Taping only

Pin Configuration

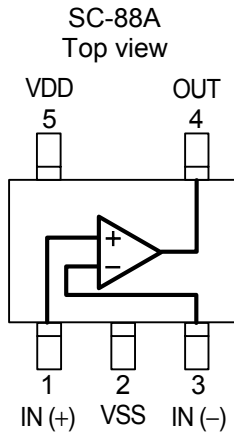

Figure 1

Table 2

Pin No.	Symbol	Description	Internal Equivalent Circuit
1	IN(+)	Non-inverted input pin	Figure 3
2	VSS	GND pin	—
3	IN(-)	Inverted input pin	Figure 3
4	OUT	Output pin	Figure 2
5	VDD	Positive power supply pin	Figure 4

Internal Equivalent Circuit

<1> Output pin

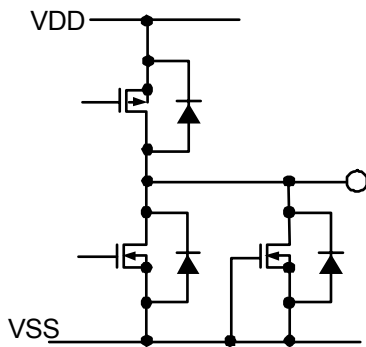

Figure 2

<2> Input pin

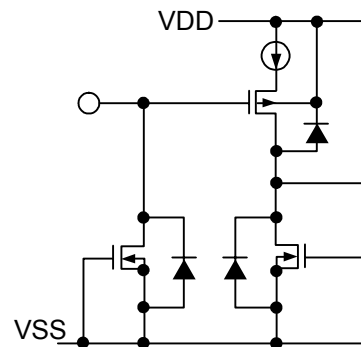

Figure 3

<3> VDD pin

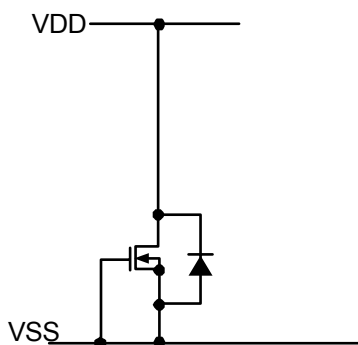

Figure 4

■ Absolute Maximum Ratings
Table 3

Parameter	Symbol	Ratings	Unit
Power supply voltage	$V_{DD} - V_{SS}$	10.0	V
Input voltage	V_{IN}	V_{SS} to V_{DD} (7.0 max.)	V
Output voltage	V_{OUT}	V_{SS} to V_{DD} (7.0 max.)	V
Differential input voltage	V_{IND}	± 7.0	V
Power dissipation	P_D	200	mW
Operating temperature range	T_{opr}	-40 to +85	°C
Storage temperature range	T_{stg}	-55 to +125	°C

Caution The absolute maximum ratings are rated values exceeding which the product could suffer physical damage. These values must therefore not be exceeded under any conditions.

■ Recommended Operating Power Supply Voltage Range
Table 4

Parameter	Symbol	Range	Unit
Operating power supply voltage range	V_{DD}	1.8 to 5.5	V

■ **Electrical Characteristics**

1. $V_{DD} = 5.0\text{ V}$

Table 5

DC Characteristics ($V_{DD} = 5.0\text{ V}$) (Ta = 25°C unless otherwise specified)

Parameter	Symbol	Measurement Conditions	Min.	Typ.	Max.	Unit	Measurement Circuit	
Current consumption	I_{DD}	S-89210A	—	50	120	μA	Figure 9	
		S-89220A	—	10	30	μA		
Input offset voltage	V_{IO}	—	-4	± 3	+4	mV	Figure 5	
Input offset current	I_{IO}	—	—	1	—	pA	—	
Input bias current	I_{BIAS}	—	—	1	—	pA	—	
Common-mode input voltage range	V_{CMR}	—	0	—	4.3	V	Figure 6	
Maximum output swing voltage	V_{OH}	$I_{OH} = 20\ \mu\text{A}$	4.7	—	—	V	Figure 7	
	V_{OL}	$I_{OL} = 20\ \mu\text{A}$	—	—	0.01		Figure 8	
Common-mode input signal rejection ratio	CMRR	—	60	70	—	dB	Figure 6	
Power supply voltage rejection ratio	PSRR	—	60	70	—	dB	Figure 5	
Source current	I_{SOURCE}	S-89210A	$V_{OH} = 0\text{ V}$	120	—	—	μA	Figure 10
		S-89220A		25	—	—		
Sink current	I_{SINK}	$V_{OL} = 0.5\text{ V}$	9	—	—	mA	Figure 11	

Table 6

AC Characteristics ($V_{DD} = 5.0\text{ V}$) (Ta = 25°C unless otherwise specified)

Parameter	Symbol	Measurement conditions	Min.	Typ.	Max.	Unit	
Rise propagation delay time	t_{PLH}	S-89210A	Overdrive = 100 mV $C_L = 15\text{ pF}$ (Refer to Figure 12.)	—	45	—	μs
		S-89220A		—	230	—	
Fall propagation delay time	t_{PHL}	S-89210A		—	9	—	
		S-89220A		—	45	—	
Rise response time	t_{TLH}	S-89210A		—	3	—	
		S-89220A		—	15	—	
Fall response time	t_{THL}	S-89210A	—	3	—		
		S-89220A	—	15	—		

MINI ANALOG SERIES CMOS COMPARATOR
S-89210A/89220A

Rev.1.3_00

2. $V_{DD} = 3.0\text{ V}$

Table 7

DC Characteristics ($V_{DD} = 3.0\text{ V}$) ($T_a = 25^\circ\text{C}$ unless otherwise specified)

Parameter	Symbol	Measurement Conditions	Min.	Typ.	Max.	Unit	Measurement Circuit	
Current consumption	I_{DD}	S-89210A	—	50	120	μA	Figure 9	
		S-89220A	—	10	30	μA		
Input offset voltage	V_{IO}	—	-4	± 3	+4	mV	Figure 5	
Input offset current	I_{IO}	—	—	1	—	pA	—	
Input bias current	I_{BIAS}	—	—	1	—	pA	—	
Common-mode input voltage range	V_{CMR}	—	0	—	2.3	V	Figure 6	
Maximum output swing voltage	V_{OH}	$I_{OH} = 20\ \mu\text{A}$	2.7	—	—	V	Figure 7	
	V_{OL}	$I_{OL} = 20\ \mu\text{A}$	—	—	0.01	V	Figure 8	
Common-mode input signal rejection ratio	CMRR	—	60	70	—	dB	Figure 6	
Power supply voltage rejection ratio	PSRR	—	60	70	—	dB	Figure 5	
Source current	I_{SOURCE}	S-89210A	$V_{OH} = 0\text{ V}$	120	—	—	μA	Figure 10
	I_{SOURCE}	S-89220A		25	—	—		
Sink current	I_{SINK}	$V_{OL} = 0.5\text{ V}$	8	—	—	mA	Figure 11	

Table 8

AC Characteristics ($V_{DD} = 3.0\text{ V}$) ($T_a = 25^\circ\text{C}$ unless otherwise specified)

Parameter	Symbol	Measurement conditions	Min.	Typ.	Max.	Unit	
Rise propagation delay time	t_{PLH}	S-89210A	Overdrive = 100 mV $C_L = 15\text{ pF}$ (Refer to Figure 12.)	—	30	—	μs
		S-89220A		—	150	—	
Fall propagation delay time	t_{PHL}	S-89210A		—	6	—	
		S-89220A		—	30	—	
Rise response time	t_{TLH}	S-89210A		—	2	—	
		S-89220A		—	10	—	
Fall response time	t_{THL}	S-89210A	—	2	—		
		S-89220A	—	10	—		

3. $V_{DD} = 1.8\text{ V}$

Table 9

DC Characteristics ($V_{DD} = 1.8\text{ V}$) (Ta = 25°C unless otherwise specified)

Parameter	Symbol	Measurement Conditions	Min.	Typ.	Max.	Unit	Measurement Circuit	
Current consumption	I_{DD}	S-89210A	—	50	120	μA	Figure 9	
		S-89220A	—	10	30	μA		
Input offset voltage	V_{IO}	—	-4	± 3	+4	mV	Figure 5	
Input offset current	I_{IO}	—	—	1	—	pA	—	
Input bias current	I_{BIAS}	—	—	1	—	pA	—	
Common-mode input voltage range	V_{CMR}	—	0	—	1.1	V	Figure 6	
Maximum output swing voltage	V_{OH}	$I_{OH} = 20\ \mu\text{A}$	1.5	—	—	V	Figure 7	
	V_{OL}	$I_{OL} = 20\ \mu\text{A}$	—	—	0.01	V	Figure 8	
Common-mode input signal rejection ratio	CMRR	—	60	70	—	dB	Figure 6	
Power supply voltage rejection ratio	PSRR	—	60	70	—	dB	Figure 5	
Source current	I_{SOURCE}	S-89210A	$V_{OH} = 0\text{ V}$	100	—	—	μA	Figure 10
	I_{SOURCE}	S-89220A		20	—	—		
Sink current	I_{SINK}	$V_{OL} = 0.5\text{ V}$	5	—	—	mA	Figure 11	

Table 10

AC Characteristics ($V_{DD} = 1.8\text{ V}$) (Ta = 25°C unless otherwise specified)

Parameter	Symbol	Measurement conditions	Min.	Typ.	Max.	Unit	
Rise propagation delay time	t_{PLH}	S-89210A	Overdrive = 100 mV $C_L = 15\text{ pF}$ (Refer to Figure 12.)	—	20	—	μs
		S-89220A		—	100	—	
Fall propagation delay time	t_{PHL}	S-89210A		—	5	—	
		S-89220A		—	25	—	
Rise response time	t_{TLH}	S-89210A		—	1.2	—	
		S-89220A		—	6	—	
Fall response time	t_{THL}	S-89210A	—	1.2	—		
		S-89220A	—	6	—		

■ Measurement Circuit

1. Power supply voltage rejection ratio, input offset voltage

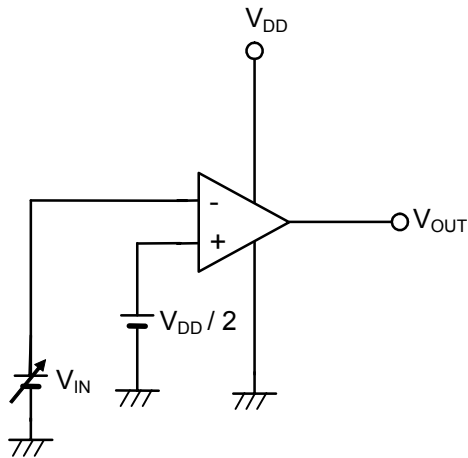

Figure 5

- **Power supply voltage rejection ratio (PSRR)**
Input offset voltage (V_{IO})

The input offset voltage (V_{IO}) is defined as $V_{IN} - V_{DD}/2$ when V_{OUT} is changed by changing V_{IN} to $V_{DD}/2$ level. The power supply voltage rejection ratio (PSRR) can be calculated by following expression, with the value of V_{IO} measured at each V_{DD} .

Measurement conditions:

When $V_{DD} = 1.8\text{ V}$: $V_{DD} = V_{DD1}$, $V_{IO} = V_{IO1}$

When $V_{DD} = 5.0\text{ V}$: $V_{DD} = V_{DD2}$, $V_{IO} = V_{IO2}$

$$PSRR = 20 \log \left(\frac{V_{DD1} - V_{DD2}}{V_{IO1} - V_{IO2}} \right)$$

2. Common-mode input signal rejection ratio, common-mode input voltage range

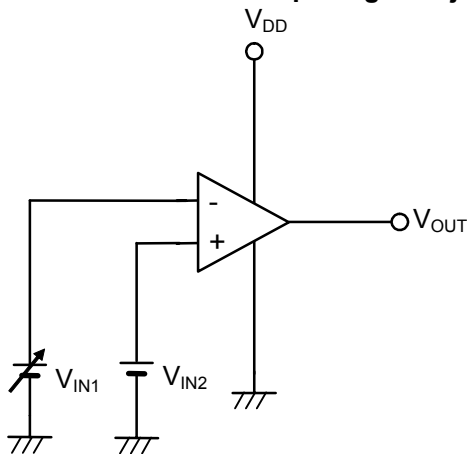

Figure 6

- **Common-mode input signal rejection ratio (CMRR)**

The common-mode input signal rejection ratio (CMRR) can be calculated by the following expression, with the offset voltage (V_{IO}) set as V_{IN1} minus V_{IN2} after V_{OUT} is changed by changing V_{IN1} .

Measurement conditions:

When $V_{IN2} = V_{CMR}(\text{max.})$: $V_{IN2} = V_{INH}$, $V_{IO} = V_{IO1}$

When $V_{IN2} = V_{DD}/2$: $V_{IN2} = V_{INL}$, $V_{IO} = V_{IO2}$

$$CMRR = 20 \log \left(\frac{V_{INH} - V_{INL}}{V_{IO1} - V_{IO2}} \right)$$

- **Common-mode input voltage range (V_{CMR})**

The common-mode input voltage range is the range of V_{IN2} in which V_{OUT} satisfies the common-mode input signal rejection ratio specifications.

3. Maximum output swing voltage

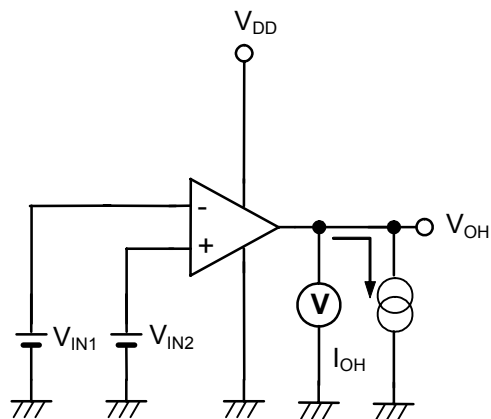

Figure 7

- **Maximum output swing voltage (V_{OH})**

Measurement conditions: $V_{IN1} = \frac{V_{DD}}{2} - 0.5V$

$V_{IN2} = \frac{V_{DD}}{2} + 0.5V$

$I_{OH} = 20 \mu A$

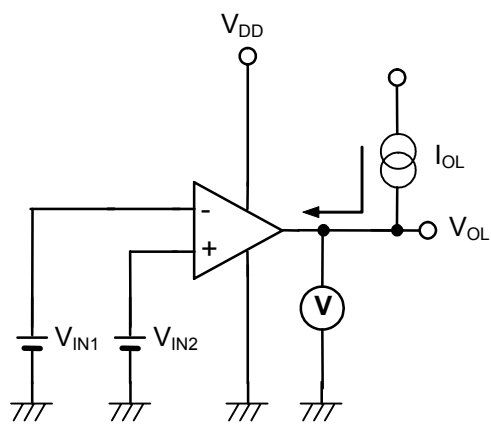

Figure 8

- **Maximum output swing voltage (V_{OL})**

Measurement conditions: $V_{IN1} = \frac{V_{DD}}{2} + 0.5V$

$V_{IN2} = \frac{V_{DD}}{2} - 0.5V$

$I_{OL} = 20 \mu A$

4. Current consumption

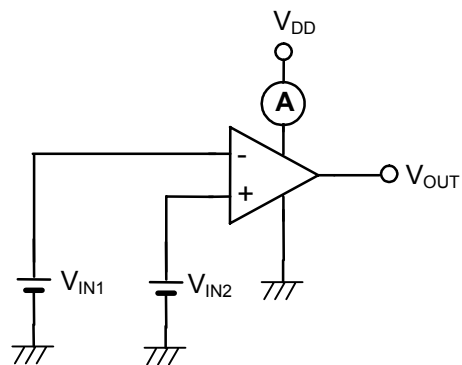

Figure 9

- **Current consumption (I_{DD})**

Measurement conditions: $V_{IN1} = V_{SS}$
 $V_{IN2} = V_{DD}$

5. Source current

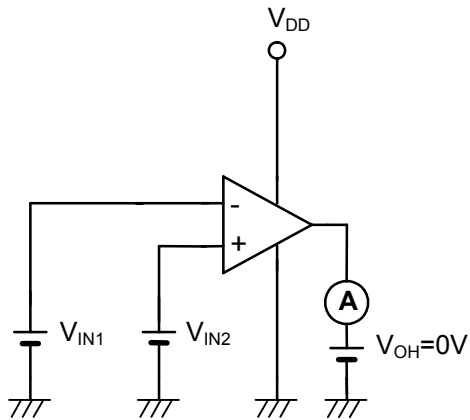

Figure 10

• Source current (I_{SOURCE})

Measurement conditions: $V_{IN1} = \frac{V_{DD}}{2} - 0.5V$

$V_{IN2} = \frac{V_{DD}}{2} + 0.5V$

6. Sink current

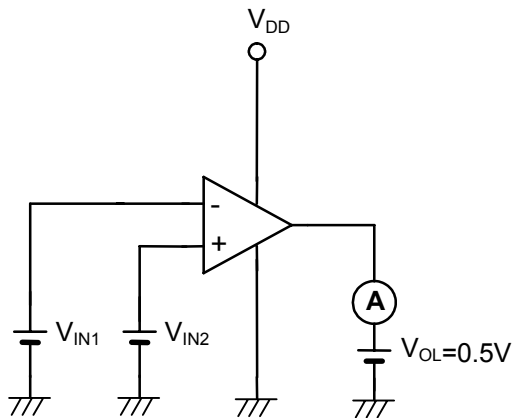

Figure 11

• Sink current (I_{SINK})

Measurement conditions: $V_{IN1} = \frac{V_{DD}}{2} + 0.5V$

$V_{IN2} = \frac{V_{DD}}{2} - 0.5V$

7. Propagation delay time / response time

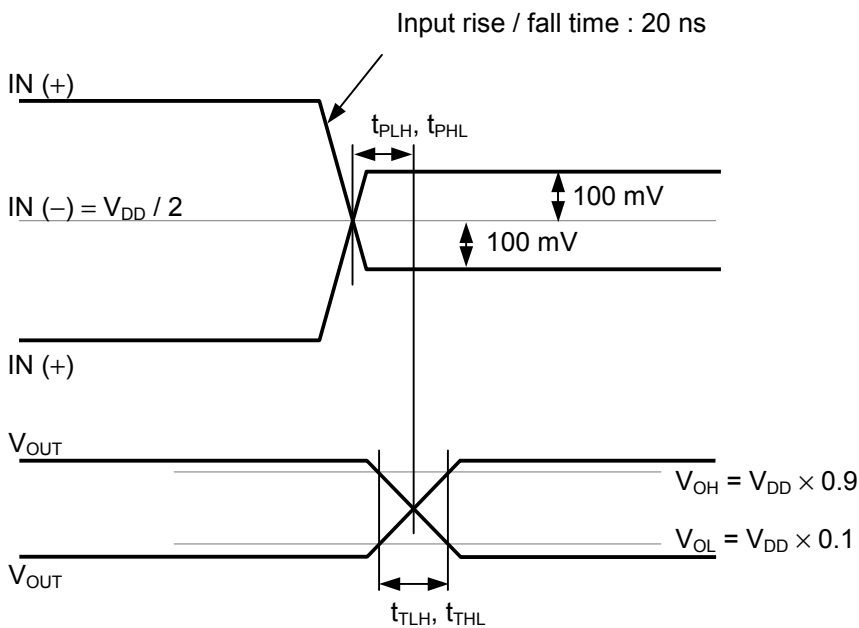

Figure 12

■ **Precaution**

- Do not apply an electrostatic discharge to this IC that exceeds performance ratings of the built-in electrostatic protection circuit.
- SII claims no responsibility for any disputes arising out of or in connection with any infringement by products including this IC of patents owned by a third party.

■ Characteristics (Reference Data)

1. Current consumption vs. Power supply voltage

(a) S-89210A

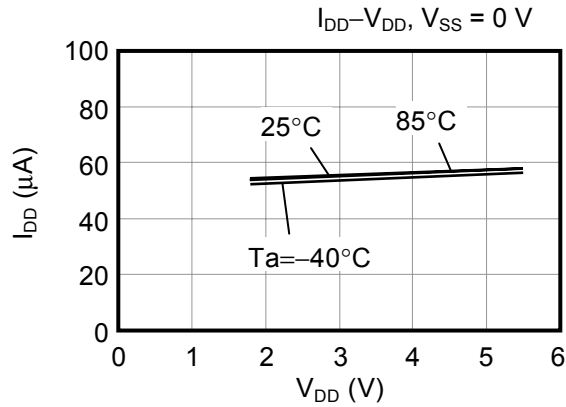

(b) S-89220A

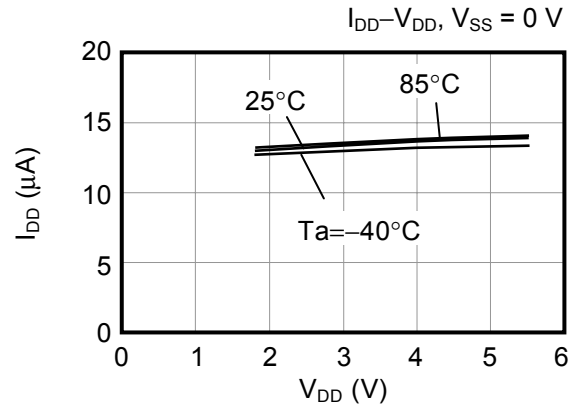

2. Output current

2-1. I_{SOURCE} vs. Power supply voltage

(a) S-89210A

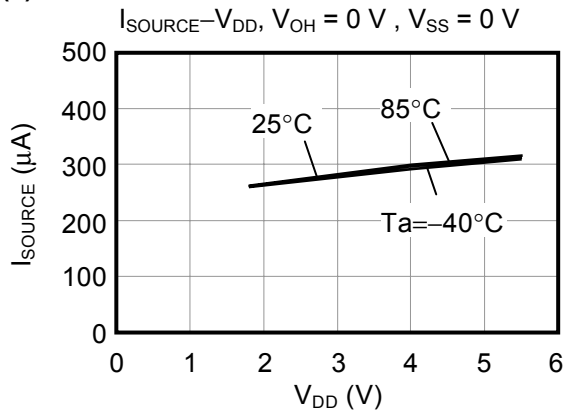

(b) S-89220A

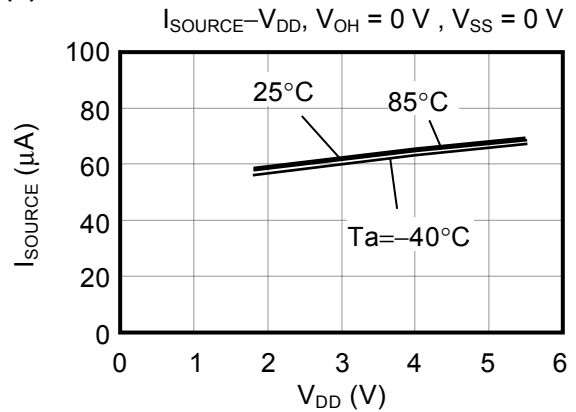

2-2. Output voltage (V_{OH}) vs. I_{SOURCE}

(a) S-89210A

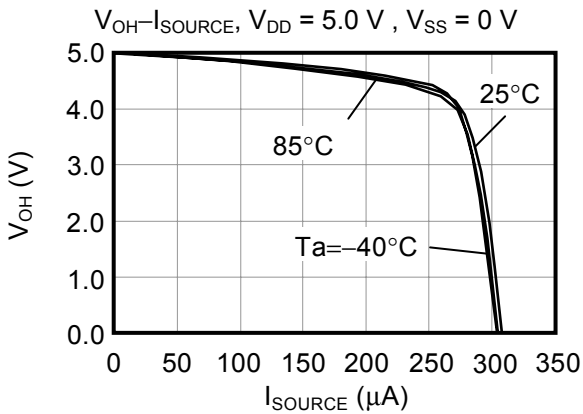
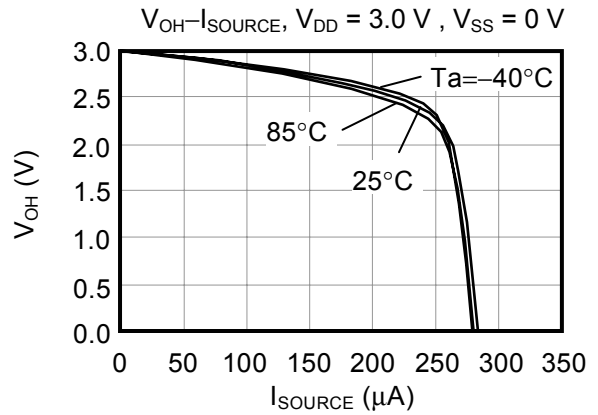
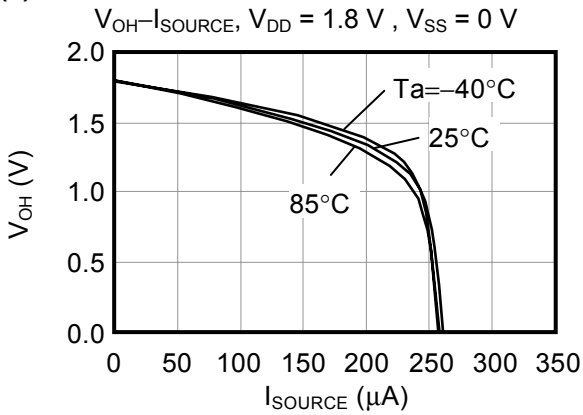

(b) S-89220A

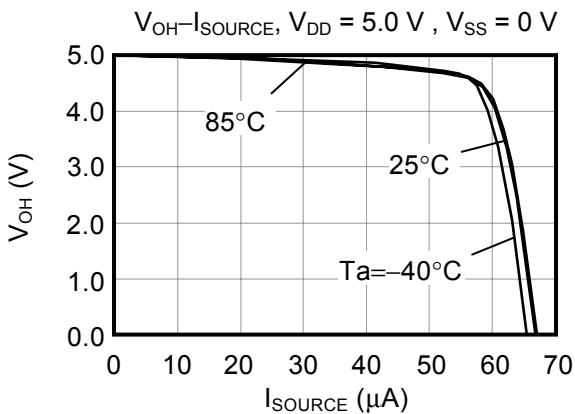
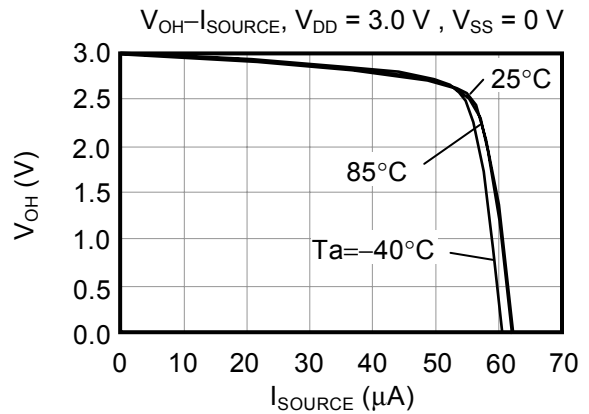
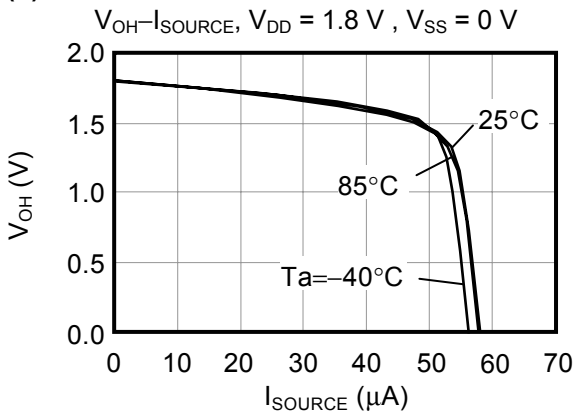

2-3. I_{SINK} vs. Power supply voltage

(a) S-89210A

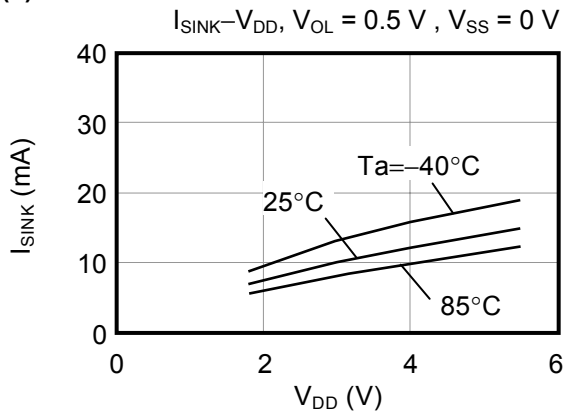

(b) S-89220A

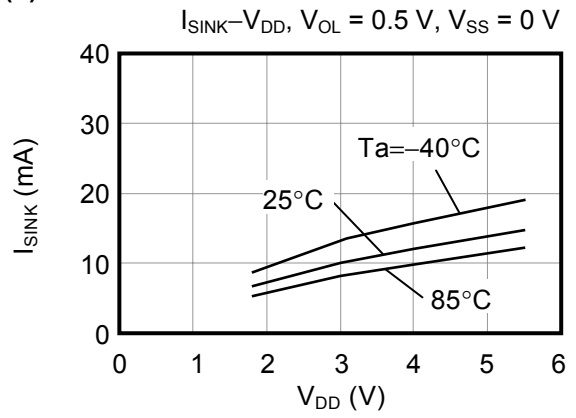

2-4. Output voltage (V_{OL}) vs. I_{SINK}

(a) S-89210A

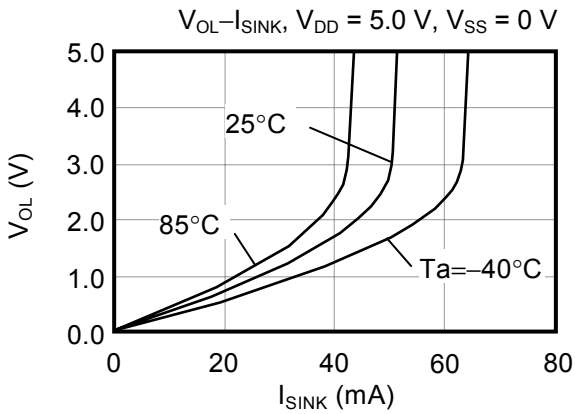
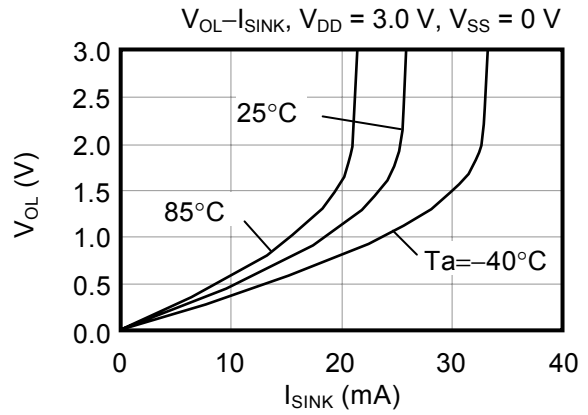
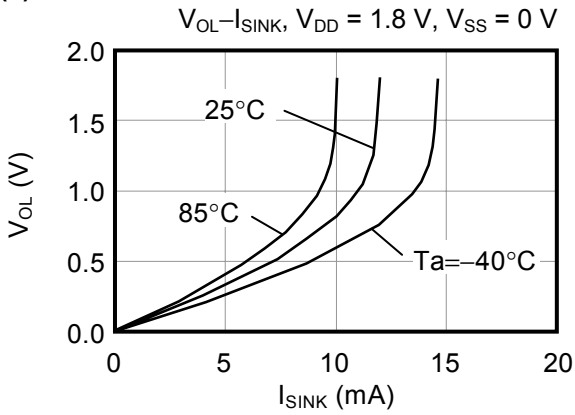

(b) S-89220A

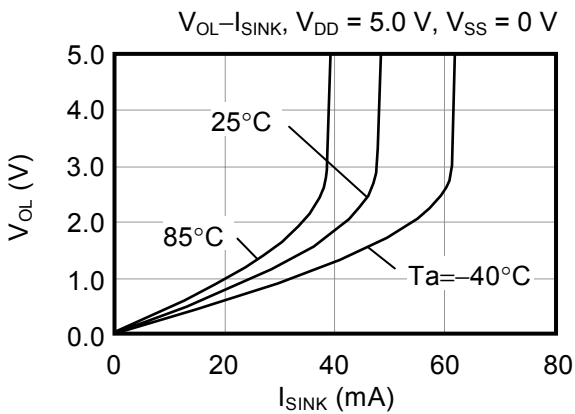
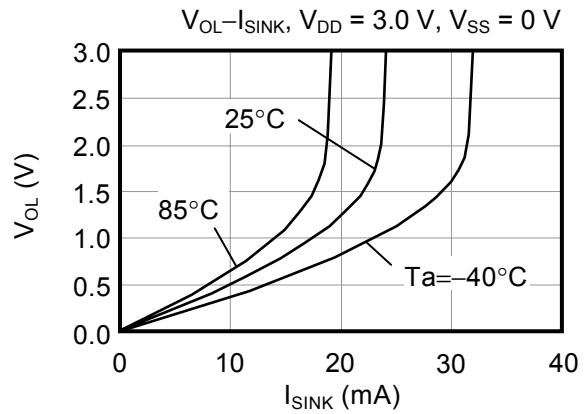
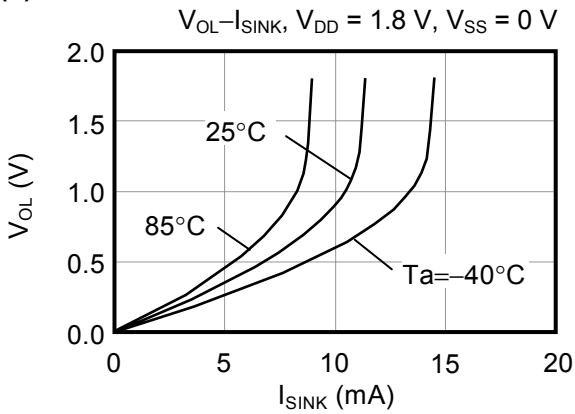

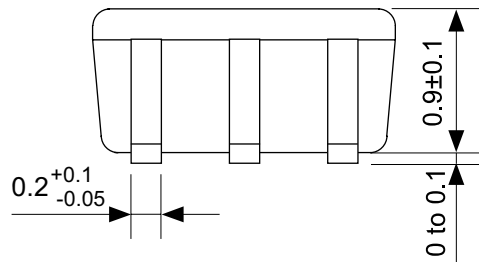
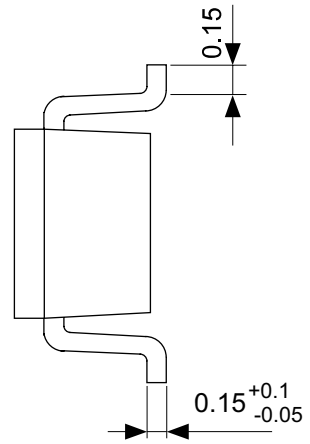
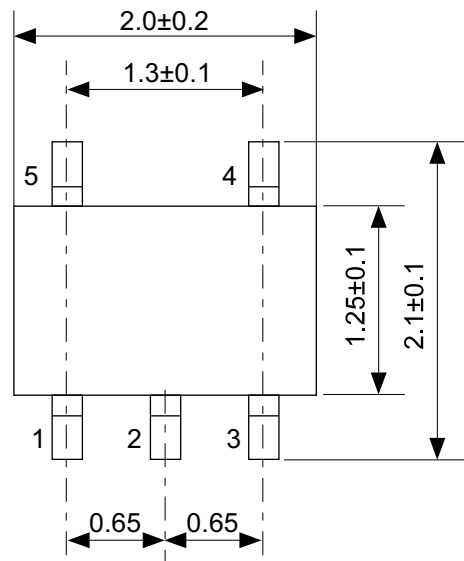

No. NP005-B-P-SD-1.1

TITLE	SC88A-B-PKG Dimensions
No.	NP005-B-P-SD-1.1
SCALE	
UNIT	mm

Seiko Instruments Inc.

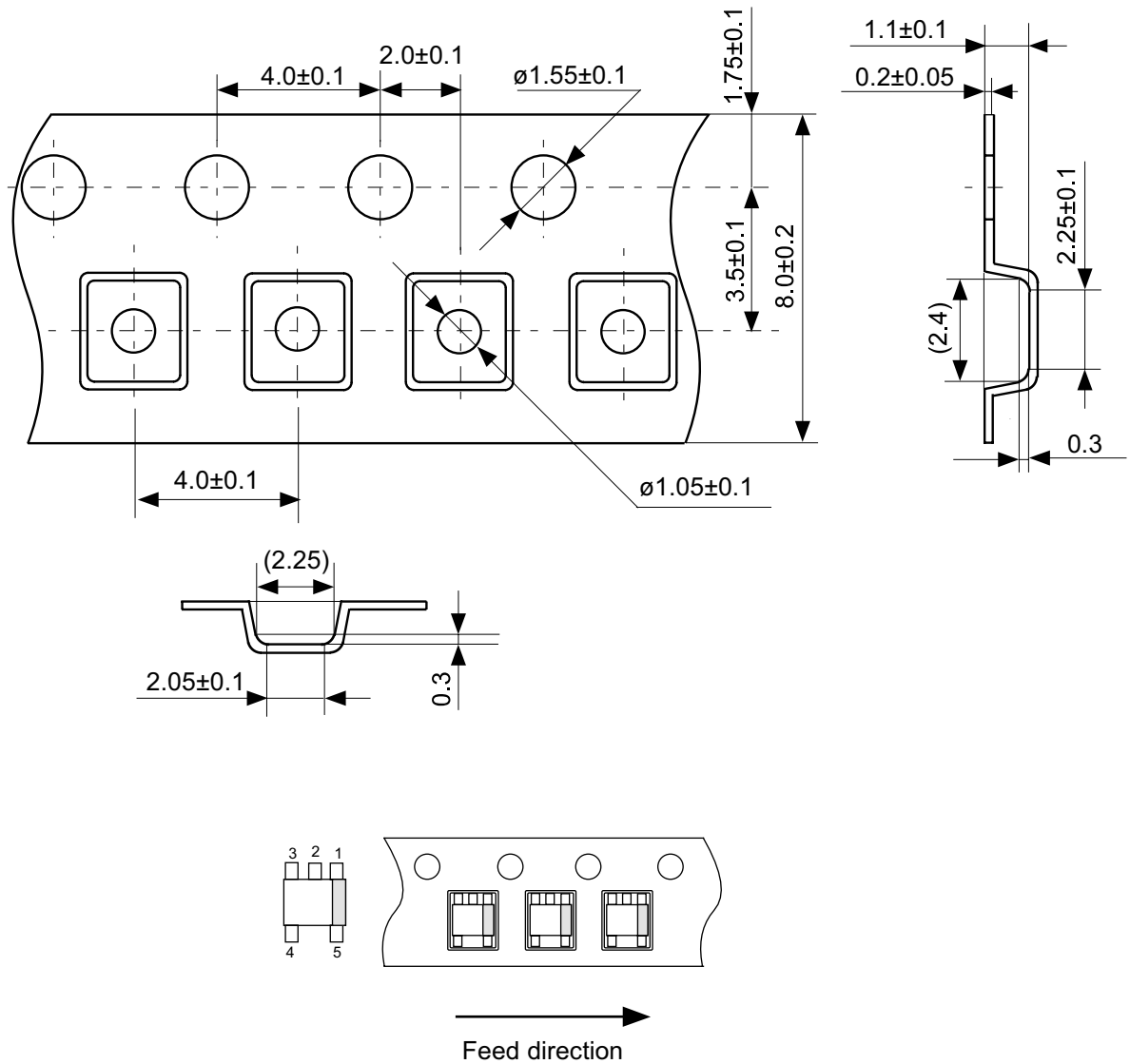

No. NP005-B-C-SD-1.1

TITLE	SC88A-B-Carrier Tape
No.	NP005-B-C-SD-1.1
SCALE	
UNIT	mm
Seiko Instruments Inc.	

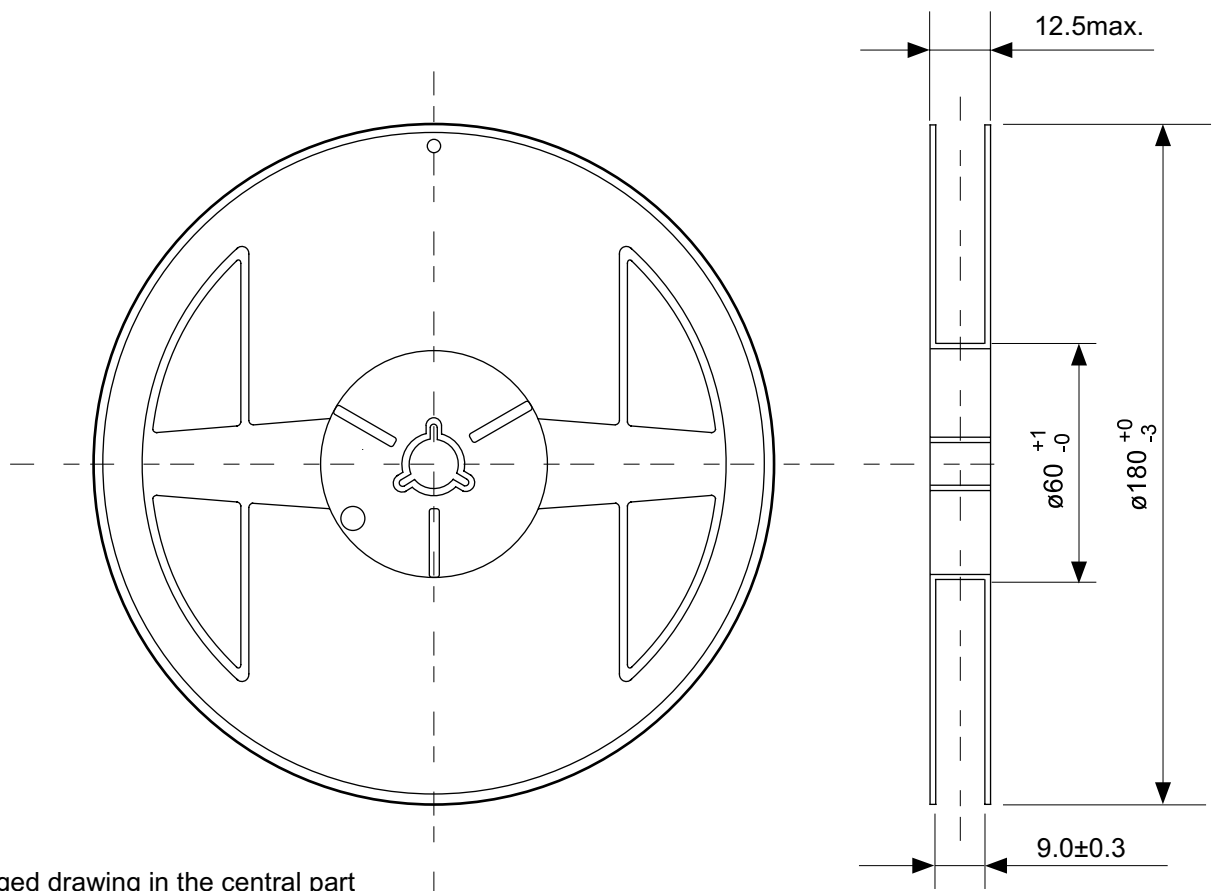

Enlarged drawing in the central part

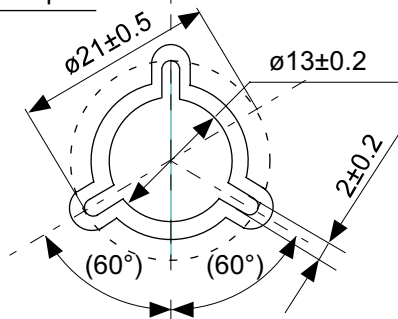

No. NP005-B-R-SD-2.1

TITLE	SC88A-B-Reel		
No.	NP005-B-R-SD-2.1		
SCALE		QTY.	3000
UNIT	mm		
Seiko Instruments Inc.			

- The information described herein is subject to change without notice.
- Seiko Instruments Inc. is not responsible for any problems caused by circuits or diagrams described herein whose related industrial properties, patents, or other rights belong to third parties. The application circuit examples explain typical applications of the products, and do not guarantee the success of any specific mass-production design.
- When the products described herein are regulated products subject to the Wassenaar Arrangement or other agreements, they may not be exported without authorization from the appropriate governmental authority.
- Use of the information described herein for other purposes and/or reproduction or copying without the express permission of Seiko Instruments Inc. is strictly prohibited.
- The products described herein cannot be used as part of any device or equipment affecting the human body, such as exercise equipment, medical equipment, security systems, gas equipment, or any apparatus installed in airplanes and other vehicles, without prior written permission of Seiko Instruments Inc.
- Although Seiko Instruments Inc. exerts the greatest possible effort to ensure high quality and reliability, the failure or malfunction of semiconductor products may occur. The user of these products should therefore give thorough consideration to safety design, including redundancy, fire-prevention measures, and malfunction prevention, to prevent any accidents, fires, or community damage that may ensue.