

| REV | DESCRIPTION | DATE | PREP | APPD |
|-----|-------------|---------|------|------|
| B | CO-29923 | 4/17/19 | HLW | HLW |

| |
|--|
| |
|--|

| | |
|--|---|
|  <small>a Microchip company</small> MOUNT HOLLY SPRINGS, PA 17065 | Specification, Hybrid TCXO Hi-Rel Standard, LVDS Output |
|--|---|

| | | | | |
|---|---------------|----------|-----------|-----|
| THE RECORD OF APPROVAL FOR THIS DOCUMENT IS MAINTAINED ELECTRONICALLY WITHIN THE ERP SYSTEM | CODE IDENT NO | SIZE | DWG. NO. | REV |
| | 00136 | A | DOC207139 | B |

| | |
|-----------------------------|---------------|
| UNSPECIFIED TOLERANCES: N/A | SHEET 1 OF 21 |
|-----------------------------|---------------|

1. SCOPE

- 1.1 General. This specification defines the design, assembly and functional evaluation of high reliability, hybrid TCXOs produced by Vectron. Devices delivered to this specification represent the standardized Parts, Materials and Processes (PMP) Program developed, implemented and certified for advanced applications and extended environments.
- 1.2 Applications Overview. The designs represented by these products were primarily developed for the MIL-Aerospace community. The lesser Design Pedigrees and Screening Options imbedded within DOC207139 bridge the gap between Space and COTS hardware by providing custom hardware with measures of mechanical, assembly and reliability assurance needed for Military, Ruggedized COTS or Commercial environments.

2. APPLICABLE DOCUMENTS

- 2.1 Specifications and Standards. The following specifications and standards form a part of this document to the extent specified herein. The issue currently in effect on the date of quotation will be the product baseline, unless otherwise specified. In the event of conflict between the texts of any references cited herein, the text of this document shall take precedence.

Military

MIL-PRF-55310 Oscillators, Crystal Controlled, General Specification For
MIL-PRF-38534 Hybrid Microcircuits, General Specification For

Standards

MIL-STD-202 Test Method Standard, Electronic and Electrical Component Parts
MIL-STD-883 Test Methods and Procedures for Microelectronics

Vectron

QSP-90100 Quality Systems Manual, Vectron
DOC011627 Identification Common Documents, Materials and Processes, Hi-Rel XO
DOC203982 DPA Specification
QSP-91502 Procedure for Electrostatic Discharge Precautions

3. GENERAL REQUIREMENTS

- 3.1 Classification. All devices delivered to this specification are of hybrid technology conforming to Type 3, Class 2 of MIL-PRF-55310. Devices carry a Class 1C ESDS classification per MIL-PRF-38534 and are marked with a single equilateral triangle at pin 1 per MIL-PRF-55310.
- 3.2 Item Identification. Unique Model Number Series' are utilized to identify device package configurations as listed in Table 1.

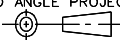
| | | | | | | |
|------------------|--------------------------------|---|--------------------------------------|-----------------------------|------------------|-------------------|
| SIZE A | CODE IDENT NO. 00136 | THIRD ANGLE PROJECTION  | UNSPECIFIED TOLERANCES N/A | DWG NO. DOC207139 | REV. B | SHEET 2 |
|------------------|--------------------------------|---|--------------------------------------|-----------------------------|------------------|-------------------|

- 3.3 Absolute Maximum Ratings.
- a. Supply Voltage Range (V_{CC}): -0.3Vdc to +4.0Vdc
 - b. Storage Temperature Range (T_{STG}): -65°C to +125°C
 - c. Junction Temperature (T_j): +150C
 - d. Lead Temperature (soldering, 10 seconds): +300°C
 - e. Weight 25 grams

3.4 Design, Parts, Materials and Processes, Assembly, Inspection and Test.

3.4.1 Design. The ruggedized designs implemented for these devices are proven in military and space applications under extreme environments. All designs utilize a 4-point crystal mount. For radiation characteristics, see paragraph 4.1.3. For all Class S and Class B products, components meet the Element Evaluation requirements of MIL-PRF-55310, Appendix B and MIL-PRF-38534, Appendix C. If Design Pedigree Code “E” is chosen, Enhanced Element Evaluation per Appendix A herein will be performed.

3.4.1.1 Design and Configuration Stability. Barring changes to improve performance by reselecting passive chip component values to offset component tolerances, there will not be fundamental changes to the design or assembly or parts, materials and processes after first product delivery of that item without written approval from the procuring activity.

3.4.1.2 Environmental Integrity. Designs have passed the environmental qualification levels of MIL-PRF-55310. These designs have also passed extended dynamic levels of at least:

- a. Sine Vibration: MIL-STD-202, Method 204, Condition G (30g pk.)
- b. Random Vibration: MIL-STD-202, Method 214, Condition II-J (43.92g rms, three minute duration in each of three mutually perpendicular directions)
- c. Mechanical Shock: MIL-STD-202, Method 213, Condition F (1500g, 0.5ms)

3.4.2 Prohibited Parts, Materials and Processes. The items listed are prohibited for use in high reliability devices produced to this specification.

- a. Gold metallization of package elements without a barrier metal.
- b. Zinc chromate as a finish.
- c. Cadmium, zinc, or pure tin external or internal to the device.
- d. Plastic encapsulated semiconductor devices.
- e. Ultrasonically cleaned electronic parts.
- f. Heterojunction Bipolar Transistor (HBT) technology.

3.4.3 Assembly. Manufacturing utilizes standardized procedures, processes and verification methods to produce MIL-PRF-55310 Class S / MIL-PRF-38534 Class K equivalent devices. MIL-PRF-38534 Group B Option 1 in-line inspection is included on levels E and R per paragraph 7.1 to further verify lot pedigree. Traceability of all components and production lots are in accordance with MIL-PRF-38534, as a minimum. Tabulated records are provided as a part of the deliverable data package. Devices are handled in accordance with Vectron document QSP-91502 (Procedure for Electrostatic Discharge Precautions).

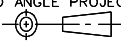
| | | | | | | |
|------------------|--------------------------------|---|--------------------------------------|-----------------------------|------------------|-------------------|
| SIZE A | CODE IDENT NO. 00136 | THIRD ANGLE PROJECTION  | UNSPECIFIED TOLERANCES N/A | DWG NO. DOC207139 | REV. B | SHEET 3 |
|------------------|--------------------------------|---|--------------------------------------|-----------------------------|------------------|-------------------|

- 3.4.4 Inspection. The inspection requirements of MIL-PRF-55310 apply to all devices delivered to this document. Inspection conditions and standards are documented in accordance with the Quality Assurance, ISO-9001 derived system of QSP-90100.
- 3.4.5 Test. The Screening test matrix of Table 4 is tailored for selectable-combination testing to eliminate costs associated with the development/maintenance of device-specific documentation packages while maintaining performance integrity.
- 3.4.6 Marking. Device marking shall be in accordance with the requirements of MIL-PRF-55310.
- 3.4.7 Ruggedized COTS Design Implementation. Design Pedigree “D” devices (see ¶ 5.2) use the same robust designs as the other device pedigrees. They do not include the provisions of traceability or the Class-qualified componentry noted in paragraphs 3.4.3 and 4.1.

4. DETAIL REQUIREMENTS

4.1 Components

- 4.1.1 Crystals. Cultured quartz crystal resonators are used to provide the selected frequency for the devices. Premium Q swept quartz is standard for all Class S level products because of its superior radiation tolerance. For Class B level products, swept quartz is optional, as required by the customer. In accordance with MIL-PRF-55310, the manufacturer has a documented crystal evaluation program.
- 4.1.2 Passive Components. Passive components will have the same pedigree as the die specified in paragraph 7.1. Where possible, for Design Pedigrees ‘E’ & ‘R’, Established Reliability (ER) failure level R and S passive components are employed. Otherwise, all components comply with the Element Evaluation requirements of MIL-PRF-38534 or Enhanced Element Evaluation as specified in Appendix A herein. When used, inductors may be open construction and may use up to 47 gauge wire.
- 4.1.3 Class S Active Devices. Active devices are procured from wafer lots that have passed MIL-PRF-38534 Class K Lot Acceptance Tests for Class S/K devices. Although radiation testing is not performed at the oscillator level, Design Pedigree Codes E and R versions of this TCXO are acceptable for use in environments of up to 100krad (Si) total dose as a result of wafer lot specific RLAT (except varactor diodes) or by analysis of the individual components. The LVDS microcircuit die is sourced in accordance with Standard Microcircuit Drawing 5962F9865107V9A, Class V (MIL-PRF-38535) qualified device. Varactor diodes are considered radiation tolerant by design. A copy of the parts list and materials can be provided for customer review upon request.
- 4.1.3.1 Class B Active Devices. When specified, active devices assembled into Pedigree Codes B and C devices (¶ 5.2a) are procured from wafer lots that have passed MIL-PRF-55310 element evaluations for Class B devices.

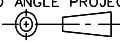
| | | | | | | |
|------------------|--------------------------------|---|--------------------------------------|-----------------------------|------------------|-------------------|
| SIZE A | CODE IDENT NO. 00136 | THIRD ANGLE PROJECTION  | UNSPECIFIED TOLERANCES N/A | DWG NO. DOC207139 | REV. B | SHEET 4 |
|------------------|--------------------------------|---|--------------------------------------|-----------------------------|------------------|-------------------|

- 4.1.4 Packages. Packages are procured that meet the construction, lead materials and finishes as specified in MIL-PRF-55310. All leads are Kovar with gold plating over a nickel underplate. Package lots are evaluated in accordance with the requirements of MIL-PRF-38534 as applicable. Vectron will not perform Salt Spray testing as part of MIL-PRF-55310 Group C/Qualification or MIL-PRF-38534 Package Element Evaluation.
- 4.1.5 Traceability and Homogeneity. All design pedigrees except option D have active device lots that are homogenous and traceable to the manufacturer's individual wafer. Swept Quartz Crystals are traceable to the quartz bar and the processing details of the autoclave lot, as applicable. All other elements and materials are traceable to their manufacturing lots. Manufacturing lot and date code information shall be recorded, by TCXO serial number, of every component and all materials used in the manufacture of that TCXO. All semiconductors used in the manufacture of a given production lot of TCXOs shall be from the same wafer and have the same manufacturing lot date code. A production lot, as defined by Vectron, is all oscillators that have been kitted and assembled as a single group. After the initial kitting and assembly, this production lot may be divided into multiple sublots to facilitate alignment and test capacity and may be sealed at multiple times within a 13 week window.
- 4.2 Mechanical.
- 4.2.1 Package Outline. Table 1 links each Hi-Rel Standard Model Number of this specification to a corresponding package style. Mechanical Outline information of each package style is found in the referenced Figure. Typical weight for all model numbers is 16 grams.
- 4.2.2 Thermal Characteristics. Because these TCXOs are multichip hybrid designs, the actual θ_{jc} to any one given semiconductor die will vary, but the combined average for all active devices results in a θ_{jc} of approximately 40°C/W. The typical die temperature rise at any one given semiconductor is 2°C to 4°C. Under no circumstance will the junction temperature ever exceed the maximum manufacturer's rated junction temperature when operated within the maximum operating temperature range.
- 4.3 Electrical.
- 4.3.1 Supply Voltage. 3.3 ±5% Vdc operation.
- 4.3.2 Temperature Range. Operating range is IAW the chosen temperature stability code.
- 4.3.3 Frequency Tolerance. Temperature stability includes initial accuracy at +25°C (with EFC), load ±10% and supply ±5%.
- 4.3.4 All devices include an External Frequency Control (EFC) pin for the purpose of externally setting each TCXO to its nominal frequency. The EFC shall be accomplished by connecting a resistor or trimmer potentiometer from that Pin to GND. The EFC resistance adjustment range is 0Ω or GND to 20KΩ max with Nominal frequency typically occurring in the 7KΩ to 13KΩ range. Customers will be furnished with the applicable EFC resistor value that can be used to set each individual device within ±0.2 ppm of nominal frequency at time of shipment.

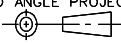
| | | | | | | |
|------------------|--------------------------------|---|--------------------------------------|-----------------------------|------------------|-------------------|
| SIZE A | CODE IDENT NO. 00136 | THIRD ANGLE PROJECTION  | UNSPECIFIED TOLERANCES N/A | DWG NO. DOC207139 | REV. B | SHEET 5 |
|------------------|--------------------------------|---|--------------------------------------|-----------------------------|------------------|-------------------|

MICROCHIP CONFIDENTIAL

4.3.5 Frequency Aging. Aging limits, when tested in accordance with MIL-PRF-55310 Group B inspection, shall not exceed ± 1 ppm for the first year and ± 5 ppm for 15 years.

4.3.5.1 Frequency Aging Duration Option. By customer request, the Aging test may be terminated after 15 days if the aging projection is less than the specified aging limit. This is a common method of expediting 30-day Aging without incurring risk to the hardware and used quite successfully for numerous customers. It is based on the ‘least squares fit’ determinations of MIL-PRF-55310 paragraph 4.8.35. Vectron’s automated aging systems acquire data every four hours, compared to the minimum MIL-PRF-55310 requirement of once every 72 hours. This makes an extensive amount of data available to perform very accurate aging projections. The delivered data would include the Aging plots projected to 30 days. If the units would not perform within that limit then they would continue to the full 30-day term. Please advise by purchase order text if this may be an acceptable option to exercise as it assists in Production Test planning.

4.3.6 Operating Characteristics. See Tables 2 and 3. Waveform measurement points and logic limits are in accordance with Table 2 and Figure 1 herein. Start-up time to reach 80% output amplitude is 10 msec typical and 30 msec maximum.

4.3.7 Output Load. See Figure 2 herein.

4.3.8 Phase Noise. See Table 2B for typical phase noise.

5. QUALITY ASSURANCE PROVISIONS AND VERIFICATION

5.1 Verification and Test. Device lots shall be tested prior to delivery in accordance with the applicable Screening Option letter as stated by the 16th character of the part number. Table 5 tests are conducted in the order shown and annotated on the appropriate process travelers and data sheets of the governing test procedure. For devices that require Screening Options that include MIL-PRF-55310 Group A Testing, the Post-Burn-In Electrical Test and the Group A Electrical Test are combined into one operation.

5.1.1 Screening Options. The Screening Options, by letter, are summarized as:

- (K) Modified MIL-PRF-38534 Class K Screening, Group A QCI and 30-day aging
- (F) MIL-PRF-55310, Rev F, Class S Screening, Groups A & B QCI
- (S) MIL-PRF-55310, Rev E, Class S Screening, Groups A & B QCI
- (C) Modified MIL-PRF-55310 Class B Screening, Groups A & B QCI
- (B) MIL-PRF-55310, Class B Screening, Groups A & B QCI
- (X) Engineering Model (EM)

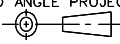
| | | | | | | |
|------------------|--------------------------------|---|--------------------------------------|-----------------------------|------------------|-------------------|
| SIZE A | CODE IDENT NO. 00136 | THIRD ANGLE PROJECTION  | UNSPECIFIED TOLERANCES N/A | DWG NO. DOC207139 | REV. B | SHEET 6 |
|------------------|--------------------------------|---|--------------------------------------|-----------------------------|------------------|-------------------|

MICROCHIP CONFIDENTIAL

5.2 Optional Design, Test and Data Parameters. The following is a list of design, assembly, inspection and test options that can be added by explicit purchase order request.

- a. Design Pedigree (choose one as the 5th character in the part number):
 - (E) Class S components, Enhanced Element Evaluation, Swept Quartz
 - (R) Class S components, Swept Quartz
 - (B) Class B components, Swept Quartz
 - (C) Class B components, Non-Swept Quartz
 - (D) COTS components, Non-Swept Quartz
- b. Input Voltage as the 15th character
- c. Frequency-Temperature Slew Test
- d. Radiographic Inspection
- e. Group C Inspection: MIL-PRF-55310 Rev E (requires 8 destruct specimens)
- f. Group C Inspection: MIL-PRF-55310, Rev F (requires 8 destruct specimens, includes Random Vibration, MIL-STD-883, Method 1014 Leak Test and Life Test)
- g. Group C Inspection: In accordance with MIL-PRF-38534, Table C-Xc, Condition PI (requires 8 destruct specimens – 5 pc. Life, 3 pc. RGA). Subgroup 1 fine leak test to be performed per MIL-STD-202, Method 112, Condition C.
- h. Internal Water-Vapor Content (RGA) samples and test performance
- i. MTBF Reliability Calculations
- j. Worst Case Analysis
- k. Derating & Thermal Analysis
- l. Deliverable Process Identification Documentation (PID)
- m. Customer Source Inspection (pre-cap / final) [Note: Model numbers 2105, 2205, 2115 and 2215 require two pre-cap inspections.]
- n. Destruct Physical Analysis (DPA): MIL-STD-1580 with exceptions as specified in Vectron DOC203982.
- o. Qualification: In accordance with MIL-PRF-55310, Rev E, Table IV (requires 11 destruct specimens).
- p. Qualification: In accordance with EEE-INST-002, Section C4, Table 3, Level 1 or 2 (requires 11 destruct specimens)
- q. High Resolution Digital Pre-Cap Photographs (20 Megapixels minimum)
- r. Hot solder dip of leads with Sn63/Pb37 solder prior to shipping.

5.2.1 NASA EEE-INST-002. A combination of Design Pedigree R, Option F Screening, and Qualification per EEE-INST-002, Section C4, Table 3 meet the requirements of Level 1 device reliability. A combination of Design Pedigree B, Option F Screening, and Qualification per EEE-INST-002, Section C4, Table 3, meet the requirements of Level 2 device reliability.

5.3 Test Conditions. Unless otherwise stated herein, inspections are performed in accordance with those specified in MIL-PRF-55310. Process travelers identify the applicable methods, conditions and procedures to be used. Examples of electrical test procedures that correspond to MIL-PRF-55310 requirements are shown in Table 3.

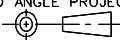
| | | | | | | |
|------------------|--------------------------------|---|--------------------------------------|-----------------------------|------------------|-------------------|
| SIZE A | CODE IDENT NO. 00136 | THIRD ANGLE PROJECTION  | UNSPECIFIED TOLERANCES N/A | DWG NO. DOC207139 | REV. B | SHEET 7 |
|------------------|--------------------------------|---|--------------------------------------|-----------------------------|------------------|-------------------|

MICROCHIP CONFIDENTIAL

- 5.4 Deliverable Data. The manufacturer supplies the following data, as a minimum, with each lot of devices (except devices with Screening Option X):”:
- a. Completed assembly and Screening lot travelers & Screening data, including rework history and Certificate of Conformance.
 - b. Electrical test variables data, identified by unique serial number.
 - c. Special items when required by purchase order such as Frequency-Temperature Slew plots, Group C data, RGA data, RLAT data.
 - d. Traceability, component LAT & enclosure LAT
- 5.5 Discrepant Material. All MRB authority resides with the procuring activity.
- 5.6 Failure Analysis. Any catastrophic failure (no output, no input current) at Post Burn-In or after will be evaluated for root cause. The customer will be notified after occurrence and upon completion of the evaluation.
6. PREPARATION FOR DELIVERY
- 6.1 Packaging. Devices will be packaged in a manner that prevents handling, ESD and transit damage during shipping.

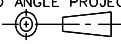
| | | | | | | |
|------------------|--------------------------------|---|--------------------------------------|-----------------------------|------------------|-------------------|
| SIZE A | CODE IDENT NO. 00136 | THIRD ANGLE PROJECTION  | UNSPECIFIED TOLERANCES N/A | DWG NO. DOC207139 | REV. B | SHEET 8 |
|------------------|--------------------------------|---|--------------------------------------|-----------------------------|------------------|-------------------|

MICROCHIP CONFIDENTIAL

7. ORDERING INFORMATION

7.1 Ordering Part Number. The ordering part number is made up of an alphanumeric series of 16 characters. Design-affected product options, identified by the parenthetic letter on the Optional Parameters list (§ 5.2a and b), are included within the device part number.

The Part Number breakdown is described as:

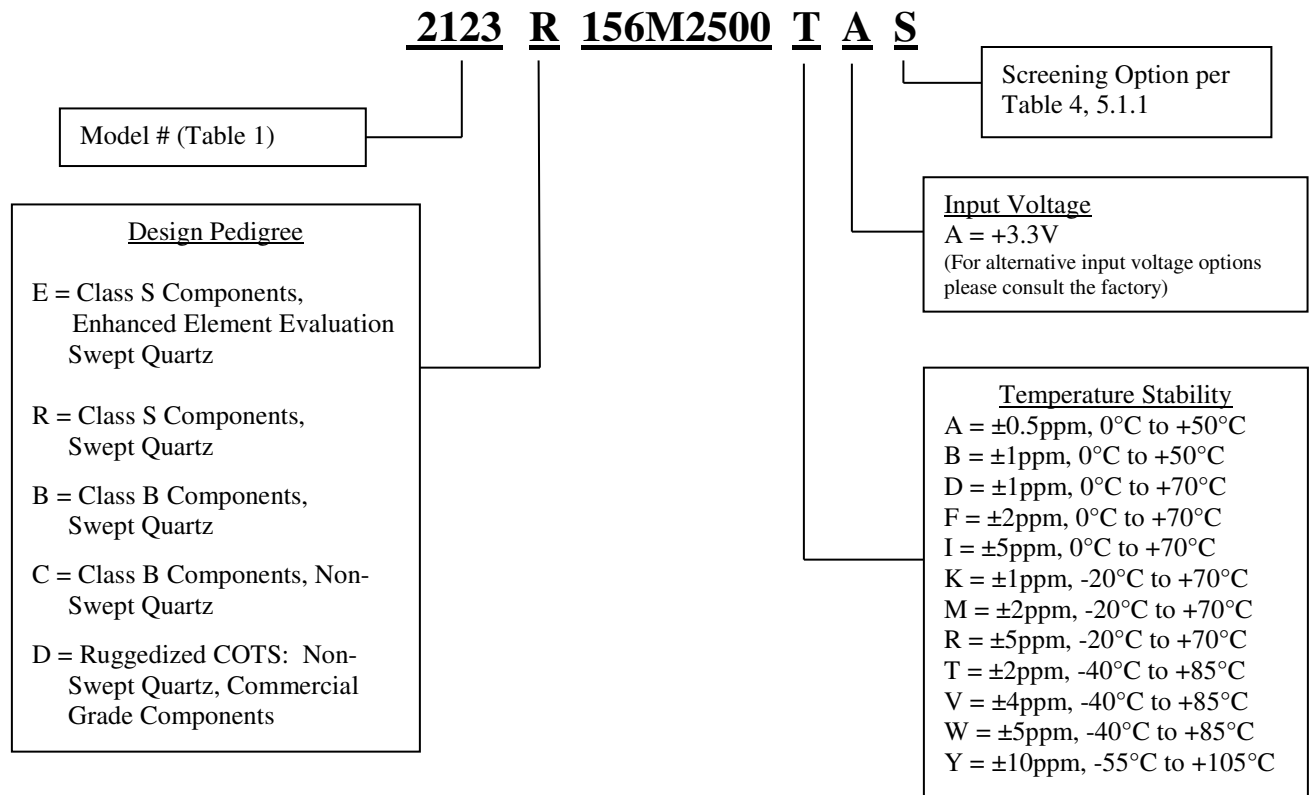

7.1.1 Model Number. The device model number is the four (4) digit number assigned to a corresponding package and output combination per Table 1.

7.1.2 Design Pedigree. Class S designs correspond to letters “E” and “R” and are described in paragraph 5.2a. Class B variants correspond to either letter “B” or “C” and are described in paragraph 5.2a. Ruggedized COTS, using commercial grade components, correspond to letter “D”.

7.1.2.1 Input Voltage. Voltage is the 15th character. Voltage availability is dependent on platform.

7.1.3 Output Frequency. The nominal output frequency is expressed in the format as specified in MIL-PRF-55310 utilizing eight (8) characters.

7.1.4 Screening Options. The 16th character is the Screening Option selected from Table 4.

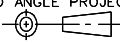
| | | | | | | |
|------------------|--------------------------------|---|--------------------------------------|-----------------------------|------------------|-------------------|
| SIZE A | CODE IDENT NO. 00136 | THIRD ANGLE PROJECTION  | UNSPECIFIED TOLERANCES N/A | DWG NO. DOC207139 | REV. B | SHEET 9 |
|------------------|--------------------------------|---|--------------------------------------|-----------------------------|------------------|-------------------|

MICROCHIP CONFIDENTIAL

7.2 Optional Design, Test and Data Parameters. Test and documentation requirements above that of the standard high reliability model shall be specified by separate purchase order line items (as listed in ¶ 5.2c thru r).

| MODEL # | PACKAGE | OUTPUT (LVDS) | MECHANICAL OUTLINE AND I/O CONNECTIONS |
|----------------|------------------|---------------|--|
| 2123 | 24 Lead Flatpack | Single Pair | Figure 3 |
| 2223 <u>2/</u> | 24 Lead Flatpack | Single Pair | Figure 4 |
| 2133 | 24 Lead Flatpack | Dual Pair | Figure 5 |
| 2233 <u>2/</u> | 24 Lead Flatpack | Dual Pair | Figure 6 |

1/. All unassigned pins have no internal connections or ties and may be externally connected to GND by the customer.

2/. Model 2223 and 2233 represent lead formed versions.

TABLE 1 - Item Identification and Package Outline

| Models 2123, 2223, 2133, 2233 | | | | |
|---|--|--|---|--------------------------|
| Supply Voltage: +3.3V ±5% | | | | |
| Single-Ended Output Voltage (+V _{OD} or -V _{OD}): 250mV to 450mV | | | | |
| Differential Output Voltage (V _{Diff}): 500mV to 900mV | | | | |
| Offset Voltage (V _{OS}): 1.125V to 1.450V | | | | |
| Frequency Range (MHz) | Max Current (V _{cc} Osc Input) (mA) <u>1/</u> | Max Current (V _{cc} LVDS Chip) (mA) <u>1/</u> | Max t _r /t _f (ps) <u>2/</u> | Duty Cycle (%) <u>2/</u> |
| 12 - 200 | 25 | 20 | 600 | 40 to 60 |

1/. Current measurements are taken at maximum supply voltage.

2/. Waveform measurement points and logic limits are in accordance with Figure 1.

TABLE 2 - Electrical Performance Characteristics

| Frequency (MHz) | Typical Period Jitter 1 sigma (ps) | Typical Period Jitter peak-to-peak (ps) | Typical Phase Jitter 12kHz to 20MHz (ps) |
|-----------------|------------------------------------|---|--|
| 136 | 3.5 | 24 | 0.15 |

TABLE 2A – Typical Jitter Performance

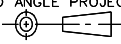
| | | | | | | |
|------------------|--------------------------------|---|--------------------------------------|-----------------------------|------------------|--------------------|
| SIZE A | CODE IDENT NO. 00136 | THIRD ANGLE PROJECTION  | UNSPECIFIED TOLERANCES N/A | DWG NO. DOC207139 | REV. B | SHEET 10 |
|------------------|--------------------------------|---|--------------------------------------|-----------------------------|------------------|--------------------|

MICROCHIP CONFIDENTIAL



TABLE 2B – Typical Phase Noise at 136 MHz

| OPERATION LISTING | REQUIREMENTS AND CONDITIONS |
|---------------------------------|---|
| Input Current (no load) | MIL-PRF-55310, Para 4.8.5.1 |
| Initial Accuracy @ Ref. Temp. | MIL-PRF-55310, Para 4.8.6 |
| Output Logic Voltage Levels | MIL-PRF-55310, Para 4.8.21.3 |
| Rise and Fall Times | MIL-PRF-55310, Para 4.8.22 |
| Duty Cycle | MIL-PRF-55310, Para 4.8.23 |
| Overvoltage Survivability | MIL-PRF-55310, Para 4.8.4 except the max voltage shall be +3.60 VDC. |
| Initial Freq. – Temp. Accuracy | MIL-PRF-55310, Para 4.8.10.1 |
| Freq. – Voltage Tolerance | MIL-PRF-55310, Para 4.8.14 |
| Start-up Time (fast/slow start) | MIL-PRF-55310, Para 4.8.29 |

TABLE 3 - Electrical Test Parameters

| | | | | | | |
|------------------|--------------------------------|----------------------------|--------------------------------------|-----------------------------|------------------|--------------------|
| SIZE A | CODE IDENT NO. 00136 | THIRD ANGLE PROJECTION | UNSPECIFIED TOLERANCES N/A | DWG NO. DOC207139 | REV. B | SHEET 11 |
|------------------|--------------------------------|----------------------------|--------------------------------------|-----------------------------|------------------|--------------------|

| OPN. NO. | OPERATION LISTING | REQUIREMENTS AND CONDITIONS | Option K | Option F | Option S | Option C | Option B | Option X |
|----------|--|--|---------------|---------------|---------------|---------------|---------------|--------------|
| | SCREENING | MIL Class Similarity (MIL-PRF-55310, Class S/B or MIL-PRF-38534, Class K) | M38534K K | M55310F S | M55310E S | M55310E B+ | M55310E B | EM |
| 1 | Non-Destruct Bond Pull | MIL-STD-883, Meth 2023 | X | X | X | NR | NR | NR |
| 2 | Internal Visual | MIL-STD-883, Meth 2017 Class K or H, Meth 2032 Class K or H | X K | X K | X K | X H | X H | X H |
| 3 | Stabilization (Vacuum) Bake | MIL-STD-883, Meth 1008, Cond C, 150°C | X 48 hrs. | X 48 hrs. | X 48 hrs. | X 48 hrs. | X 48 hrs. | X 24 hrs. |
| 4 | Thermal Shock | MIL-STD-883, Meth 1011, Cond A | X | X | X | NR | NR | NR |
| 5 | Temperature Cycle | MIL-STD-883, Meth 1010, Cond. B, 10 cycles min. | X | NR | X | X | X | NR |
| | | MIL-STD-883, Meth 1010, Cond. C, 10 cycles min. | NR | X | NR | NR | NR | NR |
| 6 | Constant Acceleration | MIL-STD-883, Meth 2001, Cond A, Y1 plane only, 5000 g's | X | X | X | X | X | NR |
| 7 | Particle Impact Noise Detection | MIL-STD-883, Meth 2020, Cond B | X | NR | X | X | NR | NR |
| | | MIL-STD-883, Meth 2020, Cond A | NR | X | NR | NR | NR | NR |
| 8 | Electrical Testing, Pre Burn-In | Nominal Vcc, +25°C | X | X | X | X | X | X |
| 9 | 1 st Burn-In | MIL-STD-883, Meth 1015, Condition B | X 160 hrs. | X 240 hrs. | X 240 hrs. | X 160 hrs. | X 160 hrs. | NR |
| 10 | Electrical Testing, Intermediate | Nominal Vcc, +25°C & Op Temp Extremes | X | NR | NR | NR | NR | NR |
| 11 | 2 nd Burn-In | MIL-STD-883, Meth 1015, Condition B | X 160 hrs. | NR | NR | NR | NR | NR |
| 12 | Electrical Testing, Post Burn-In | Nominal Vcc & extremes, nominal temperature & extremes | X | X | X | X | X | NR |
| 13 | Seal: Fine Leak | MIL-STD-202, Meth 112, Cond C, 5 x 10 ⁻⁸ atm cc/sec max | X | NR | X | X | X | X |
| | | MIL-STD-883, Meth. 1014, TC A2 or B1 | NR | X | NR | NR | NR | NR |
| 14 | Seal: Gross Leak | MIL-STD-202, Meth 112, Cond D | X | NR | X | X | X | X |
| | | MIL-STD-883, Meth. 1014, TC B2 or B3 | NR | X | NR | NR | NR | NR |
| 15 | Radiographic Inspection | MIL-STD-883, Meth 2012 | X | X | X | X | NR | NR |
| 16 | Solderability | MIL-STD-883, Meth 2003 | 1/ | 1/ | 1/ | 1/ | 1/ | 1/ |
| 17 | External Visual Inspection | MIL-STD-883, Method 2009 | X | X | X | X | X | NR |
| 18 | Group A Electrical Test | MIL-PRF-55310 | X | X | X | Sample | Sample | NR |
| 19 | Aging, 30 Day <u>2/</u> (M55310 Group B) | MIL-PRF-55310, para. 4.8.35.1 | X | X | X | Sample | Sample | NR |
| 20 | Group C Inspection (optional) | See Para 5.2 herein for details of supplier recommended Group C Inspection options | Para 5.2(g) | Para 5.2(f) | Para 5.2(e) | Para 5.2(e) | Para 5.2(e) | NR |

LEGEND: X = Required, NR = Not Required, AR = As Required

TABLE 4 - Screening & Test Matrix

1/ Performed at package LAT. Include LAT data sheet.

2/ By customer request, the Aging test may be terminated after 15 days if the projected aging rate is meeting the specification requirements as described in paragraph 4.3.5.1 herein. Must be explicitly stated on the customer PO.

| | | | | | | |
|------------------|--------------------------------|---|--------------------------------------|-----------------------------|------------------|--------------------|
| SIZE A | CODE IDENT NO. 00136 | THIRD ANGLE PROJECTION  | UNSPECIFIED TOLERANCES N/A | DWG NO. DOC207139 | REV. B | SHEET 12 |
|------------------|--------------------------------|---|--------------------------------------|-----------------------------|------------------|--------------------|

MICROCHIP CONFIDENTIAL

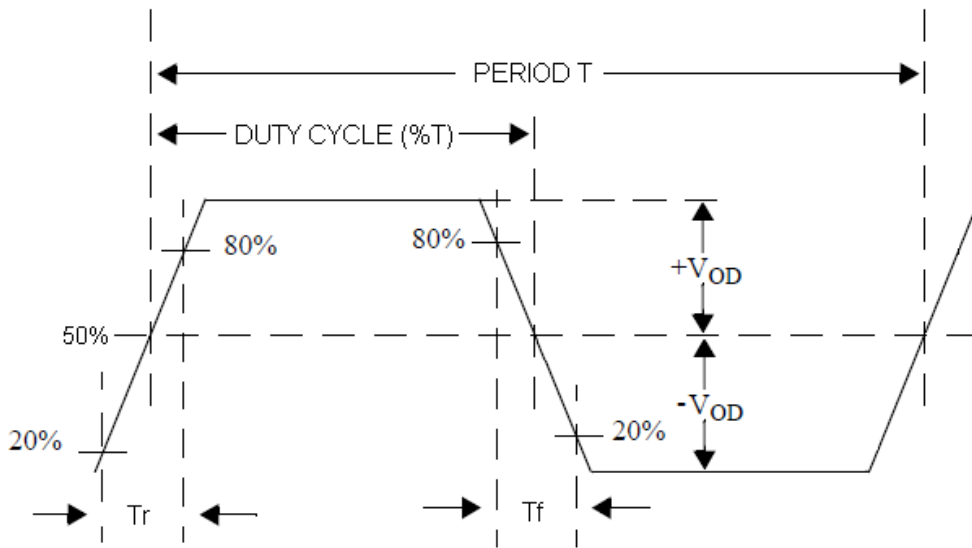

Figure 1
Differential Output Waveform

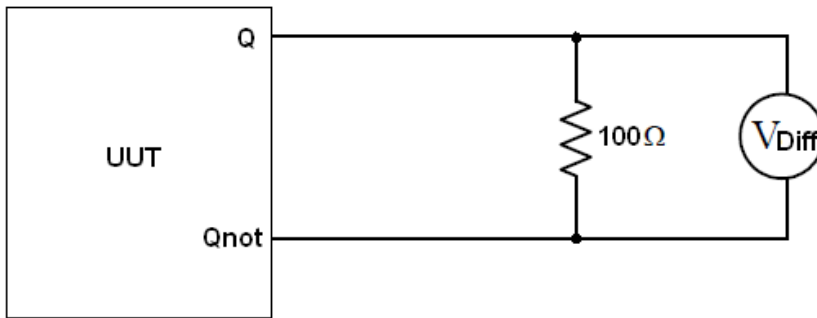
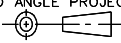
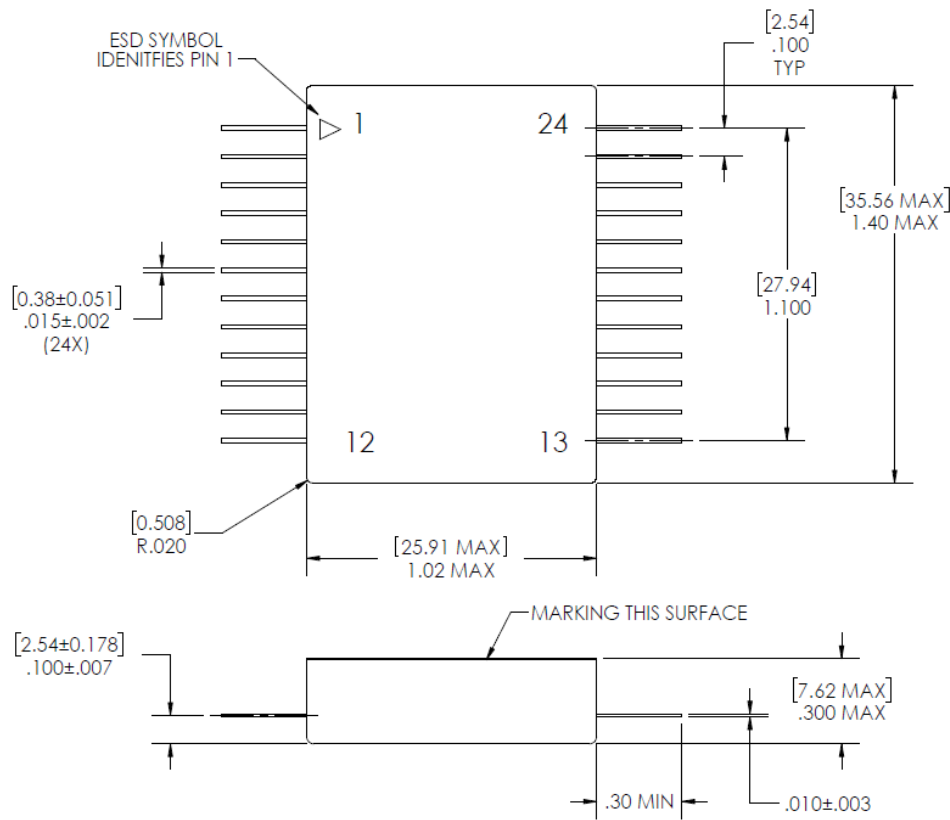

Figure 2
Output Load

| | | | | | | |
|------------------|--------------------------------|---|--------------------------------------|-----------------------------|------------------|--------------------|
| SIZE A | CODE IDENT NO. 00136 | THIRD ANGLE PROJECTION  | UNSPECIFIED TOLERANCES N/A | DWG NO. DOC207139 | REV. B | SHEET 13 |
|------------------|--------------------------------|---|--------------------------------------|-----------------------------|------------------|--------------------|



PIN CONNECTIONS

- 1 = EXTERNAL FREQUENCY CONTROL
- 2 THRU 11 = NO INTERNAL CONNECTION
- 12 = GND & CASE GND
- 13 = OUTPUT Q
- 14 = OUTPUT Q
- 15 = Vcc for LVDS Chip
- 16 = ENABLE
Floating or Logic '0' Enables both Outputs
Logic '1' Disables both Outputs
- 17 THRU 23 = NO INTERNAL CONNECTION
- 24 = Vcc for OSCILLATOR CIRCUIT

NOTES

1. PIN NUMBERS ARE FOR REFERENCE ONLY AND DO NOT APPEAR ON THE UNIT
2. 'NO INTERNAL CONNECTION' PINS MAY BE EXTERNALLY GROUNDED.
3. ENCLOSURE MATERIAL: KOVAR
4. ENCLOSURE PLATING: GOLD OVER NICKEL

**FIGURE 3 Single LVDS pair
Models 2123 Package Outline**

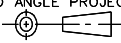
| | | | | | | |
|------------------|--------------------------------|---|--------------------------------------|-----------------------------|------------------|--------------------|
| SIZE A | CODE IDENT NO. 00136 | THIRD ANGLE PROJECTION  | UNSPECIFIED TOLERANCES N/A | DWG NO. DOC207139 | REV. B | SHEET 14 |
|------------------|--------------------------------|---|--------------------------------------|-----------------------------|------------------|--------------------|

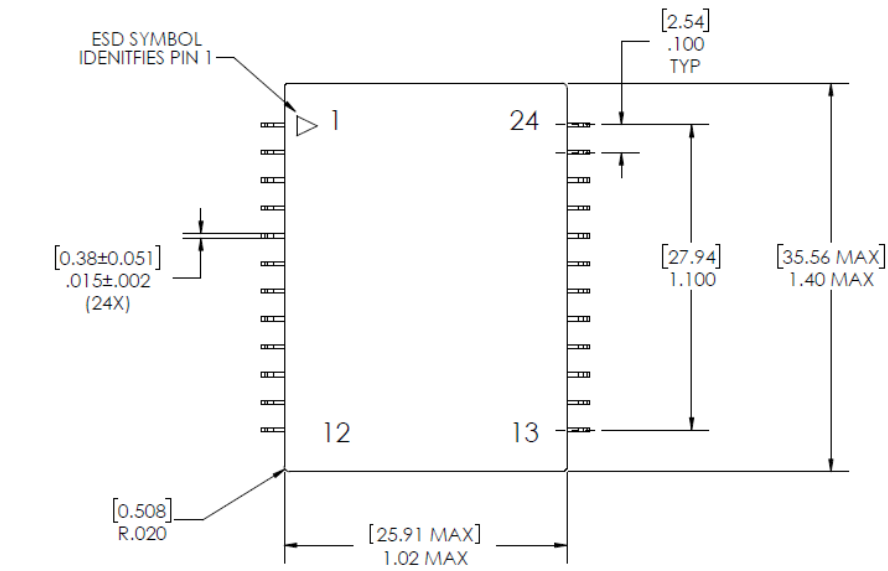

PIN CONNECTIONS

- 1 = EXTERNAL FREQUENCY CONTROL
- 2 THRU 11 = NO INTERNAL CONNECTION
- 12 = GND & CASE GND
- 13 = OUTPUT Q
- 14 = OUTPUT Q
- 15 = Vcc for LVDS Chip
- 16 = ENABLE
Floating or Logic '0' Enables both Outputs
Logic '1' Disables both Outputs
- 17 THRU 23 = NO INTERNAL CONNECTION
- 24 = Vcc for OSCILLATOR CIRCUIT

NOTES

1. PIN NUMBERS ARE FOR REFERENCE ONLY AND DO NOT APPEAR ON THE UNIT
2. 'NO INTERNAL CONNECTION' PINS MAY BE EXTERNALLY GROUNDED.
3. ENCLOSURE MATERIAL: KOVAR
4. ENCLOSURE PLATING: GOLD OVER NICKEL

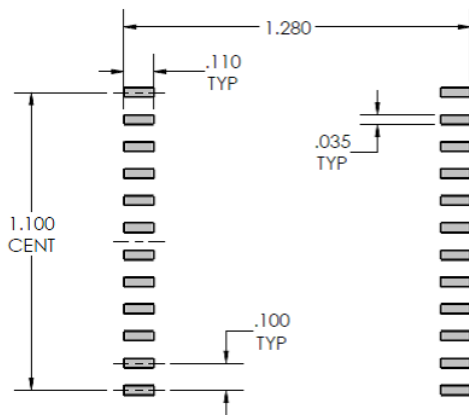
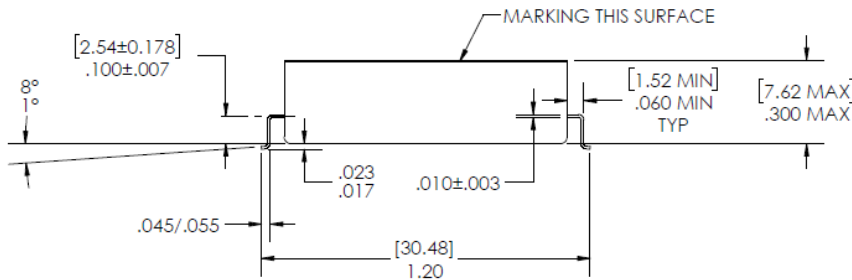

RECOMMENDED PAD LAYOUT FOR MOUNTING FORMED PACKAGE

FIGURE 4 Single pair LVDS Models 2223 Package Outline

| | | | | | | |
|------------------|--------------------------------|----------------------------|--------------------------------------|-----------------------------|------------------|--------------------|
| SIZE A | CODE IDENT NO. 00136 | THIRD ANGLE PROJECTION | UNSPECIFIED TOLERANCES N/A | DWG NO. DOC207139 | REV. B | SHEET 15 |
|------------------|--------------------------------|----------------------------|--------------------------------------|-----------------------------|------------------|--------------------|

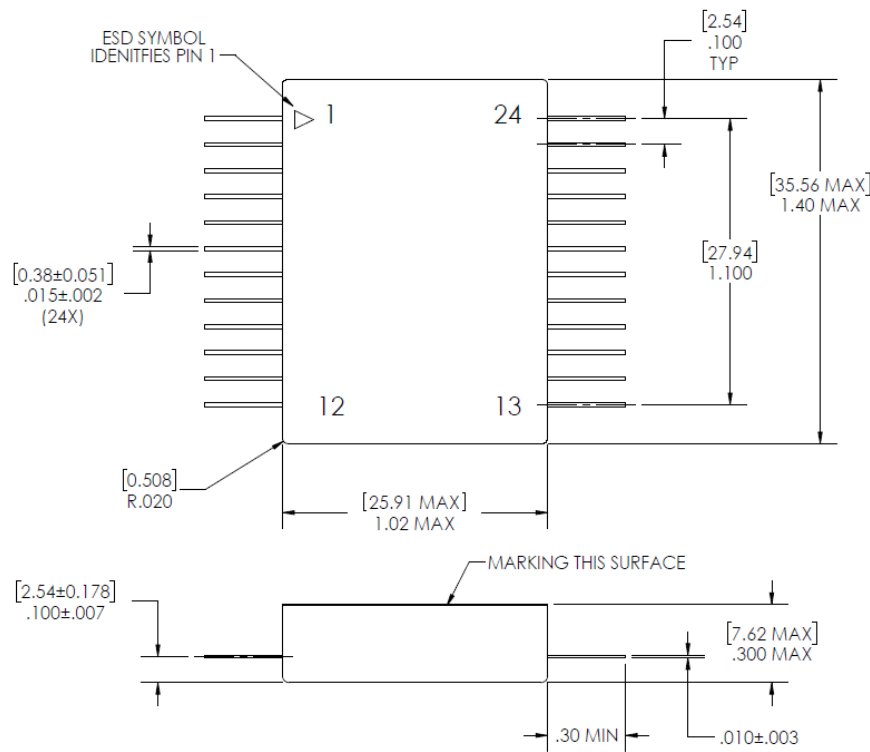

PIN CONNECTIONS

- 1 = EXTERNAL FREQUENCY CONTROL
- 2 THRU 11 = NO INTERNAL CONNECTION
- 12 = GND & CASE GND
- 13 = Vcc for LVDS Chip
- 14 = OUTPUT 1Q
- 15 = OUTPUT 1Q
- 16 = OUTPUT 2Q
- 17 = OUTPUT 2Q
- 18 = GND & CASE GND
- 19 THRU 23 = NO INTERNAL CONNECTION
- 24 = Vcc for OSCILLATOR CIRCUIT

NOTES

1. PIN NUMBERS ARE FOR REFERENCE ONLY AND DO NOT APPEAR ON THE UNIT
2. 'NO INTERNAL CONNECTION' PINS MAY BE EXTERNALLY GROUNDED.
3. ENCLOSURE MATERIAL: KOVAR
4. ENCLOSURE PLATING: GOLD OVER NICKEL

**FIGURE 5 Dual pair LVDS
Models 2133 Package Outline**

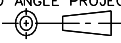
| | | | | | | |
|------------------|--------------------------------|---|--------------------------------------|-----------------------------|------------------|--------------------|
| SIZE A | CODE IDENT NO. 00136 | THIRD ANGLE PROJECTION  | UNSPECIFIED TOLERANCES N/A | DWG NO. DOC207139 | REV. B | SHEET 16 |
|------------------|--------------------------------|---|--------------------------------------|-----------------------------|------------------|--------------------|

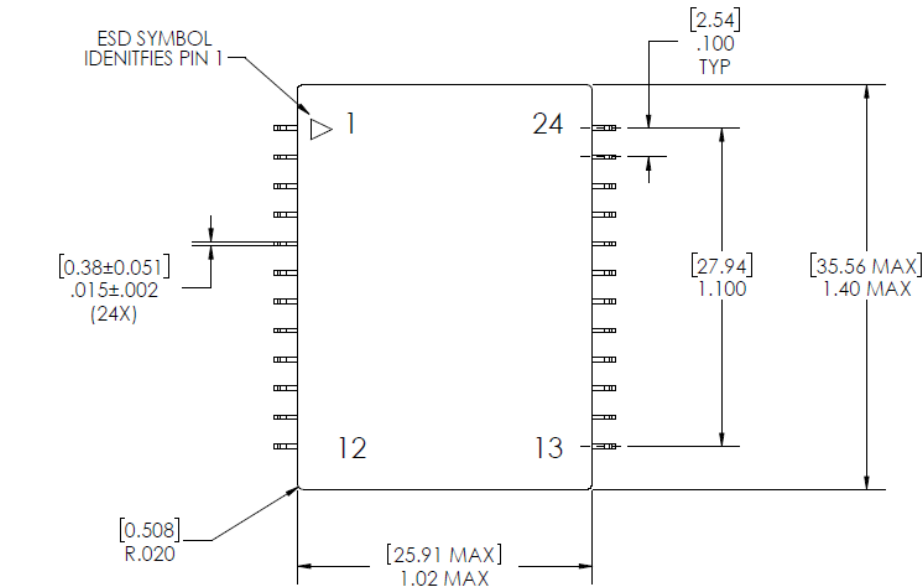

PIN CONNECTIONS

- 1 = EXTERNAL FREQUENCY CONTROL
- 2 THRU 11 = NO INTERNAL CONNECTION
- 12 = GND & CASE GND
- 13 = Vcc for LVDS Chip
- 14 = OUTPUT 1Q
- 15 = OUTPUT 1Q
- 16 = OUTPUT 2Q
- 17 = OUTPUT 2Q
- 18 = GND & CASE GND
- 19 THRU 23 = NO INTERNAL CONNECTION
- 24 = Vcc for OSCILLATOR CIRCUIT

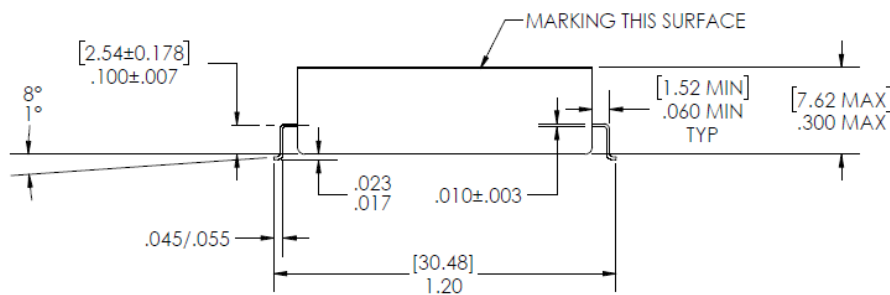

NOTES

1. PIN NUMBERS ARE FOR REFERENCE ONLY AND DO NOT APPEAR ON THE UNIT
2. 'NO INTERNAL CONNECTION' PINS MAY BE EXTERNALLY GROUNDED.
3. ENCLOSURE MATERIAL: KOVAR
4. ENCLOSURE PLATING: GOLD OVER NICKEL

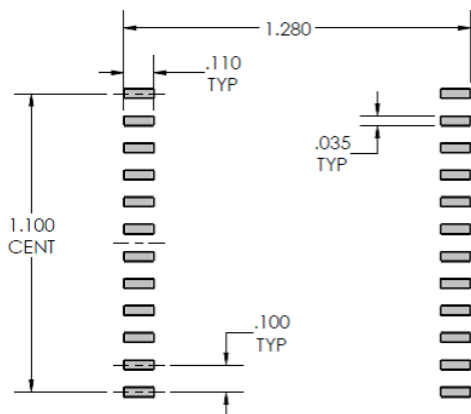

RECOMMENDED PAD LAYOUT FOR MOUNTING FORMED PACKAGE

FIGURE 6 Dual pair LVDS Models 2233 Package Outline

| | | | | | | |
|------------------|--------------------------------|---|--------------------------------------|-----------------------------|------------------|--------------------|
| SIZE A | CODE IDENT NO. 00136 | THIRD ANGLE PROJECTION  | UNSPECIFIED TOLERANCES N/A | DWG NO. DOC207139 | REV. B | SHEET 17 |
|------------------|--------------------------------|---|--------------------------------------|-----------------------------|------------------|--------------------|

Appendix A

ENHANCED ELEMENT EVALUATION

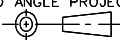
| | | | | | | |
|------------------|--------------------------------|---|--------------------------------------|-----------------------------|------------------|--------------------|
| SIZE A | CODE IDENT NO. 00136 | THIRD ANGLE PROJECTION  | UNSPECIFIED TOLERANCES N/A | DWG NO. DOC207139 | REV. B | SHEET 18 |
|------------------|--------------------------------|---|--------------------------------------|-----------------------------|------------------|--------------------|

MICROCHIP CONFIDENTIAL

MICROCIRCUIT ENHANCED ELEMENT EVALUATION

| Subgroup | Class K | Test | Mil-STD-883 | | Quantity (accept number) | Mil-PRF-38534 Reference Paragraph |
|----------|------------|--|--------------|--|-------------------------------------|---|
| | | | Method | Condition | | |
| 1 | X | Element Electrical A. May perform at wafer level B. All failures shall be removed from the lot C. Perform at room ambient | | | 100% | C.3.3.1 |
| 2 | X | Element Visual | 2010 | | 100% | C.3.3.2 |
| 3 | X | Internal Visual | 2010 | | 10(0) or 22(0) (See Notes 1 & 2) | C.3.3.3 C.3.3.4.2 |
| 4 | X | Temperature Cycling | 1010 | C | 10(0) 22(0) (See Notes 1 & 2) | C.3.3.3 |
| | X | Mechanical Shock or Constant Acceleration | 2002 2001 | B, Y1 direction 3,000 G, Y1 direction | | |
| | X | Interim Electrical | | | | C.3.3.4.3 |
| | X | Burn-In | 1015 | 240 hours minimum at +125°C | | |
| | X | Post Burn-In Electrical | | | | C.3.3.4.3 |
| | X | Steady State Life | 1005 | | | |
| | X | Final Electrical | | | | C.3.3.4.3 |
| 5 | X | Wire Bond Evaluation | 2011 | | 10(0) wires or 20(1) wires | C.3.3.3 C.3.3.5 |
| 6 | X | SEM | 2018 | | See method 2018 & Note 2 | C.3.3.6 |

NOTES:

- Subgroups 3, 4, & 5 shall be performed on a sample of 10 die if the wafer lot is from a QPL/QML line. If the die are from commercial wafer lots, then the sample size shall be 22 die. Die from QPL/QML wafers not meeting the QPL/QML requirements and downgraded to commercial grade shall not be used.
- Subgroups 3, 4 & 5 shall be performed in the order listed in Table 1. Subgroup 6 may be performed at any time.

| | | | | | | |
|------------------|--------------------------------|---|--------------------------------------|-----------------------------|------------------|--------------------|
| SIZE A | CODE IDENT NO. 00136 | THIRD ANGLE PROJECTION  | UNSPECIFIED TOLERANCES N/A | DWG NO. DOC207139 | REV. B | SHEET 19 |
|------------------|--------------------------------|---|--------------------------------------|-----------------------------|------------------|--------------------|

MICROCHIP CONFIDENTIAL

SEMICONDUCTOR ENHANCED ELEMENT EVALUATION

| Subgroup | Class K | Test | Mil-STD-750 | | Quantity (accept number) | Mil-PRF-38534 Reference Paragraph |
|----------|------------|--|---------------------------------|--|-------------------------------------|---|
| | | | Method | Condition | | |
| 1 | X | Element Electrical A. May perform at wafer level B. All failures shall be removed from the lot | | Perform at room ambient | 100% | C.3.3.1 |
| 2 | X | Element Visual | 2069, 2070, 2072, 2073 | | 100% | C.3.3.2 |
| 3 | X | Internal Visual | 2069, 2070, 2072, 2073, 2074 | | 10(0) or 22(0) (Notes 1 & 2) | C.3.3.3 C.3.3.4.2 |
| 4 | X | Temperature Cycling | 1051 | C | 10(0) 22(0) (See Notes 1 & 2) | C.3.3.3 |
| | X | Surge Current (when applicable) | 4066 | A or B as specified | | |
| | X | Constant Acceleration | 2006 2001 | Y1 direction 20,000 G / 10,000 G for Pd ≥ 10W | | |
| | X | Interim Electrical | | | | C.3.3.4.3 |
| | X | High Temperature Reverse Bias (HTRB) | 1039 1042 1038 | A B A | | |
| | X | Interim Electrical & Delta | | Complete Within 16 hrs of HTRB completion | | |
| | X | Burn-In 240 hours | 1039, 1042 1038 1040 | B,A B | | |
| | X | Post Burn-In Electrical | | | | C.3.3.4.3 |
| | X | Steady State Life 1000 hours or equivalent per MIL-PRF-19500 | 1026 1037 1042 1048 | | | |
| | X | Final Electrical | | | | C.3.3.4.3 |
| 5 | X | Wire Bond Evaluation | 2011 | | 10(0) wires or 20(1) wires | C.3.3.3 C.3.3.5 |
| 6 | X | SEM | 2018 2077 | | See method 2018 or 2077 & Note 2 | C.3.3.6 |

NOTES:

- Subgroups 3, 4, & 5 shall be performed on a sample of 10 die if the wafer lot is from a QPL/QML line. If the die are from commercial wafer lots, then the sample size shall be 22 die. Die from QPL/QML wafers not meeting the QPL/QML requirements and downgraded to commercial grade shall not be used.
- Subgroups 3, 4 & 5 shall be performed in the order listed in Table 1. Subgroup 6 may be performed at any time.

| | | | | | | |
|------------------|--------------------------------|---|--------------------------------------|-----------------------------|------------------|--------------------|
| SIZE A | CODE IDENT NO. 00136 | THIRD ANGLE PROJECTION  | UNSPECIFIED TOLERANCES N/A | DWG NO. DOC207139 | REV. B | SHEET 20 |
|------------------|--------------------------------|---|--------------------------------------|-----------------------------|------------------|--------------------|

MICROCHIP CONFIDENTIAL

PASSIVE COMPONENTS ENHANCED ELEMENT EVALUATION

| Part Type | Test | Requirements Paragraph | Sample Size | Allowable Rejects |
|---|---|------------------------|--------------------|--------------------|
| Ceramic capacitors (Production lot definition shall be per M55681 or M123 for chips, or M49470 T-level for stacks) | | | | |
| M55681 FRL S or M123 (chips) | N/A | N/A | N/A | N/A |
| DSCC Dwg COTS (chips) | Ultrasonic scan or CSAM | M123 | 100% | N/A |
| | Group A | M123 | M123 | M123 |
| | Group B, Subgroups 1 & 2 | M123 | M123 | M123 |
| T-level M49470 (stacked) | N/A | N/A | N/A | N/A |
| General purpose M49470, DSCC dwg or COTS (stacked) | Ultrasonic scan or CSAM | M49470 for T-level | 100% | N/A |
| | Group A | M49470 for T-level | M49470 for T-level | M49470 for T-level |
| | Group B, Subgroups 2, 4 & 5b | M49470 for T-level | M49470 for T-level | M49470 for T-level |
| Tantalum Chip Capacitors (Note: Stacking tantalum chips will require a repeat of the entire Group A in M55365 with minimum Weibull C and surge current option C. Production lot definition shall be per M55365.) | | | | |
| M55365 | Group A (Weibull C minimum with surge current option C) | M55365 | M55365 | M55365 |
| DSCC Dwg, COTS | Group A (Weibull C minimum with surge current option C) | M55365 | M55365 | M55365 |
| | Group C | M55365 | M55365 | M55365 |
| Resistor Chips (Note: Gluing one resistor chip on top of another to change a design or save on real estate is not allowable without extensive design/process verification, long term testing, and hybrid re-qualification. Production lot definition shall be per M55342). | | | | |
| M55342 FRL R or S | N/A | N/A | N/A | N/A |
| DSCC Dwg, COTS | Group A | M55342 for T-level | M55342 for T-level | M55342 for T-level |
| | Group B | M55342 for T-level | M55342 for T-level | M55342 for T-level |
| Inductors (See Paragraph 4.1.2) | | | | |
| Magnetics, Closed Construction Leaded and Surface Mount (transformers, inductors, coils) (Note: Stacking magnetics shall be qualified and the effects of the long term performance of the hybrids verified. When stacking magnetics, a repeat of the thermal cycling plus electrical measurements as specified in Group A of Mil-Std-981. Design, workmanship and materials/processes shall conform to MIL-STD-981 requirements). | | | | |
| Magnetics, Open Construction are unencapsulated and unpotted self-leaded parts consisting of magnet wire wound around a magnetic core. These parts are fully visually inspectable. Open construction magnetics shall be subjected to 100% electrical measurements and visual inspection per Mil-Std-981. | | | | |
| Custom closed magnetics | Group A | Mil-STD-981 | Mil-STD-981 | Mil-STD-981 |
| | Group B | Mil-STD-981 | Mil-STD-981 | Mil-STD-981 |

| | | | | | | |
|------------------|--------------------------------|---|--------------------------------------|-----------------------------|------------------|--------------------|
| SIZE A | CODE IDENT NO. 00136 | THIRD ANGLE PROJECTION  | UNSPECIFIED TOLERANCES N/A | DWG NO. DOC207139 | REV. B | SHEET 21 |
|------------------|--------------------------------|---|--------------------------------------|-----------------------------|------------------|--------------------|

MICROCHIP CONFIDENTIAL