

Advance Information

16M CMOS Dynamic RAM Family

Extended Data Out, x4, 2K and 4K Refresh

The family of 16M dynamic RAMs is fabricated using 0.5μ CMOS high-speed silicon-gate process technology. It includes devices organized as 4,194,304 four-bit words. Advanced circuit design and fine line processing provide high performance, improved reliability, and low cost.

The x4 devices with 4096 cycle refresh (MCM516405CV) require 12 address lines (12 rows, 10 columns), while the x4 devices with 2048 cycle refresh (MCM517405CV) require only 11 address lines.

These devices are packaged in a standard 300 mil J-lead small outline package (SOJ) and a 300 mil thin-small-outline package (TSOP).

- Three-State Data Output
- Extended Data Out
- LVTTTL-Compatible Inputs and Outputs
- RAS-Only Refresh
- CAS Before RAS Refresh
- Hidden Refresh
- 2048 Cycle Refresh: MCM517405CV = 32 ms
- 4096 Cycle Refresh: MCM516405CV = 64 ms
- Fast Access Time (t_{RAC}):
 - MCM51x405C-60 = 60 ns (Max)
 - MCM51x405C-70 = 70 ns (Max)
- Low Power
 - MCM516405CV-60 = 288 mW (Active)
 - MCM516405CV-70 = 252 mW
 - MCM517405CV-60 = 360 mW (Active)
 - MCM517405CV-70 = 324 mW
 - 1.8 mW Max Standby
- Single Power Supply of 3.3 V ± 0.3 V

4M x 4

MCM516405CV
Extended Data Out
4096 Cycle Refresh

MCM517405CV
Extended Data Out
2048 Cycle Refresh

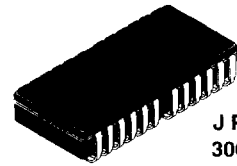

J PACKAGE
300 MIL SOJ
CASE 880A-02

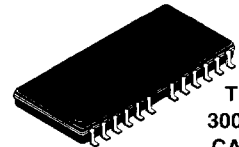

T PACKAGE
300 MIL TSOP II
CASE 892A-02

PIN ASSIGNMENT

300 MIL SOJ
300 MIL TSOP

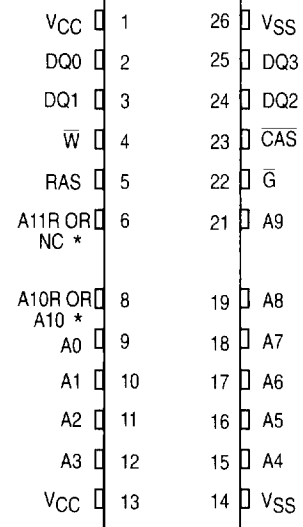

* 4096 Cycle Refresh or
2048 Cycle Refresh
(R suffix = Row Address)

PIN NAMES

A0 - A11	Address Input	\bar{CAS}	Column Address Strobe
DQ0 - DQ3	Data Input/Output	VCC	Power Supply (+ 5 V)
\bar{G}	Output Enable	VSS	Ground
\bar{W}	Read/Write Enable	NC	No Connection
RAS	Row Address Strobe		

MOTOROLA 91

This document contains information on a new product. Specifications and information herein are subject to change without notice.

10/4/96

BLOCK DIAGRAMS
4096 CYCLE REFRESH BLOCK DIAGRAM
MCM516405CV

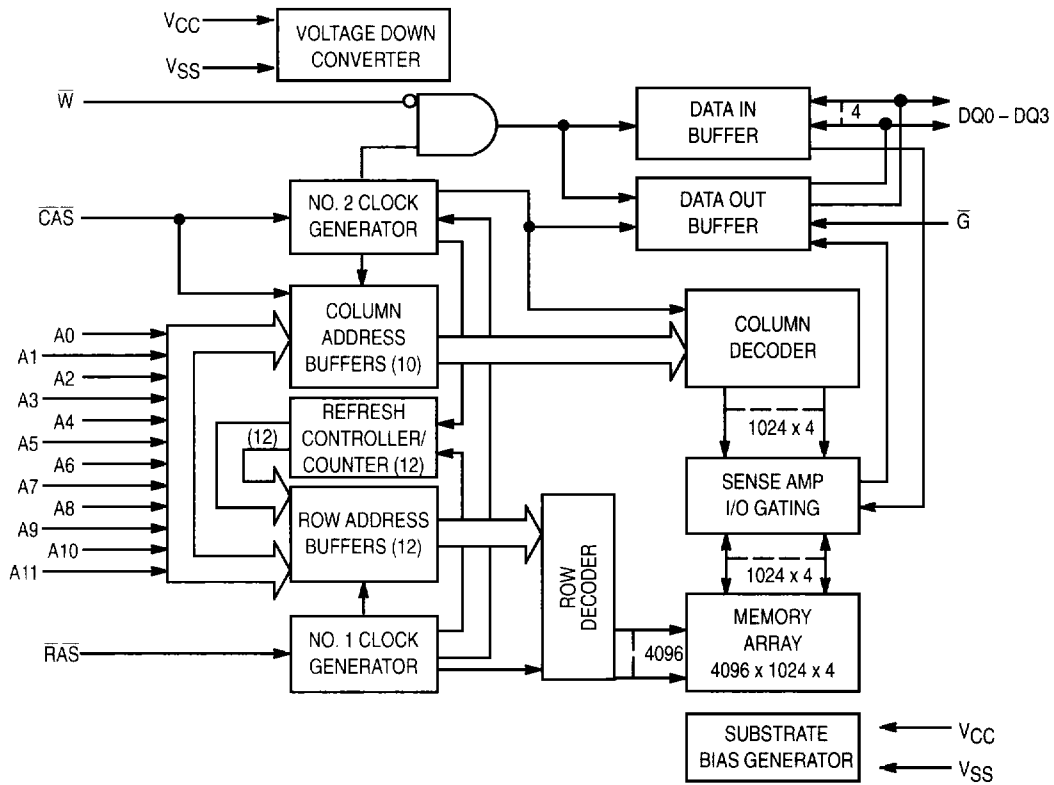

2048 CYCLE REFRESH BLOCK DIAGRAM
MCM517405CV

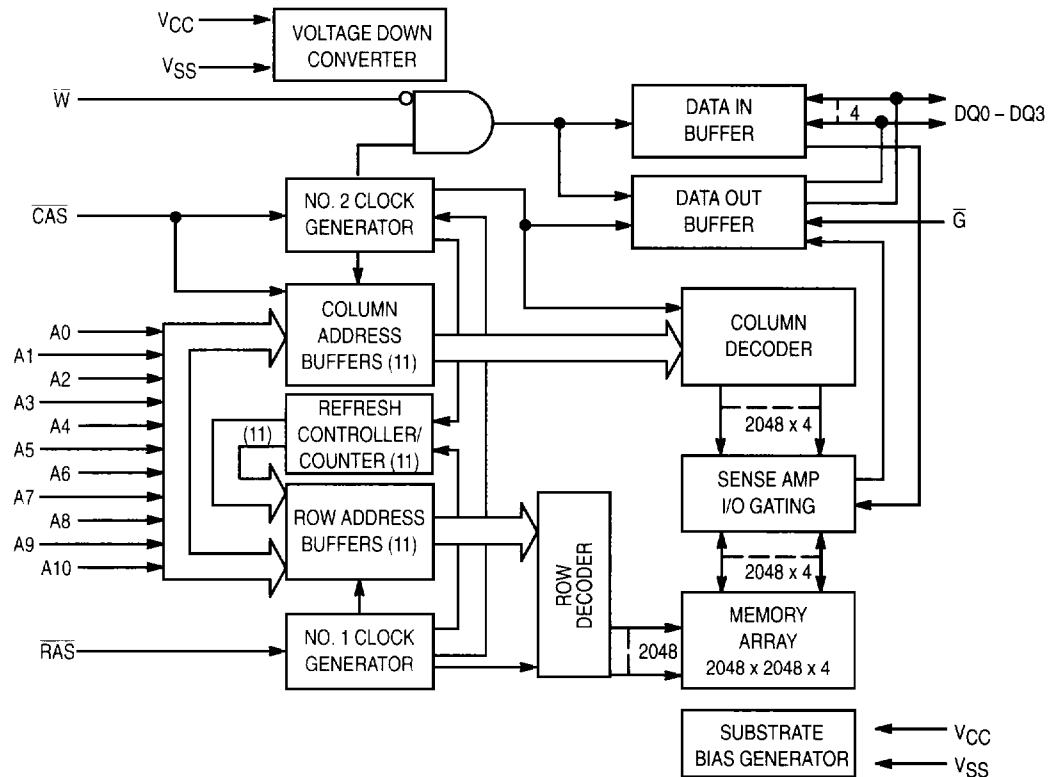

ABSOLUTE MAXIMUM RATINGS (See Note)

Rating	Symbol	Value	Unit
Power Supply Voltage	V_{CC}	- 0.3 V to 4.6 V	V
Voltage Relative to V_{SS} for Any Pin Except V_{CC}	V_{in}, V_{out}	- 0.3 V to $V_{CC} + 0.3$ V	V
Data Output Current	I_{out}	50	mA
Power Dissipation	P_D	900	mW
Operating Temperature Range	T_A	0 to + 70	°C
Storage Temperature Range	T_{stg}	- 55 to + 150	°C

This device contains circuitry to protect the inputs against damage due to high static voltages or electric fields; however, it is advised that normal precautions be taken to avoid application of any voltage higher than maximum rated voltages to these high-impedance circuits.

NOTE: Permanent device damage may occur if ABSOLUTE MAXIMUM RATINGS are exceeded. Functional operation should be restricted to RECOMMENDED OPERATING CONDITIONS. Exposure to higher than recommended voltages for extended periods of time could affect device reliability.

DC OPERATING CONDITIONS AND CHARACTERISTICS

($V_{CC} = 3.3$ V \pm 0.3 V, $T_A = 0$ to 70°C, Unless Otherwise Noted)

RECOMMENDED OPERATING CONDITIONS (All Voltages Referenced To V_{SS})

Parameter	Symbol	Min	Typ	Max	Unit
Supply Voltage (Operating Voltage Range)	V_{CC}	3	3.3	3.6	V
	V_{SS}	0	0	0	
Logic High Voltage, All Inputs	V_{IH}	2.2	—	$V_{CC} + 0.3$ V*	V
Logic Low Voltage, All Inputs	V_{IL}	- 0.3**	—	0.8	V

* $V_{CC} + 1.2$ V at pulse width \leq 20 ns.

** -1.2 V at pulse width \leq 20 ns.

DC CHARACTERISTICS AND SUPPLY CURRENTS (See Note 1)

Characteristic	Symbol	Min	Max	Unit	Notes
V_{CC} Power Supply Current (Operating) MCM516405CV-60 MCM516405CV-70 MCM517405CV-60 MCM517405CV-70	I_{CC1}	—	80 70 100 90	mA	2, 3, 4
V_{CC} Power Supply Current (Standby) ($\overline{RAS} = \overline{CAS} = V_{IH}$) Output Open	I_{CC2}	—	1	mA	
V_{CC} Power Supply Current During \overline{RAS} -Only Refresh Cycles ($\overline{CAS} = V_{IH}$) Output Open MCM516405CV-60 MCM516405CV-70 MCM517405CV-60 MCM517405CV-70	I_{CC3}	—	80 70 100 90	mA	2, 4
V_{CC} Power Supply Current During Extended Data Out Cycle ($\overline{RAS} = V_{IL}$), (\overline{CAS} cycling) Output Open MCM517405CV-60 MCM517405CV-70 MCM516405CV-60 MCM516405CV-70	I_{CC4}	—	90 80 80 75	mA	2, 3, 4
V_{CC} Power Supply Current (Standby) ($\overline{RAS} = \overline{CAS} = V_{CC} - 0.5 V$)	I_{CC5}	—	0.5	mA	
V_{CC} Power Supply Current During \overline{CAS} or Before \overline{RAS} Refresh Cycle, Output Open MCM516405CV-60 MCM516405CV-70 MCM517405CV-60 MCM517405CV-70	I_{CC6}	—	80 70 100 90	mA	2, 4
Input Leakage Current ($0 V \leq V_{in} \leq V_{CC}$, Other Input Pins = 0 V)	$I_{lkg(I)}$	-10	10	μA	
Output Leakage Current ($0 V \leq V_{out} \leq 5.5 V$, Q Floating)	$I_{lkg(O)}$	-10	10	μA	
Output High Voltage ($I_{OH} = -2 mA$)	V_{OH}	2.4	—	V	
Output Low Voltage ($I_{OL} = +2 mA$)	V_{OL}	—	0.4	V	

NOTES:

1. All voltages are referenced to V_{SS} .
2. I_{CC1} , I_{CC3} , I_{CC4} , and I_{CC6} depend on cycle rate.
3. I_{CC1} , I_{CC4} , depend on output loading. Specified values are obtained with the output open.
4. Address can be changed once or less while $\overline{RAS} = V_{IL}$. In case of I_{CC4} , it can be changed once or less during an extended data out cycle (t_{PC}).

CAPACITANCE ($f = 1 MHz$, $T_A = 25^\circ$, $V_{CC} = 5 V$, Periodically Sampled Rather Than 100% Tested)

Characteristic	Symbol	Max	Unit
Input Capacitance A0 – A11, D G, \overline{RAS} , \overline{CAS} , W	C_{in}	5	pF
		7	
I/O Capacitance ($\overline{CAS} = V_{IH}$ to Disable Output) DQ0 – DQ3, Q	$C_{I/O}$	7	pF

NOTE: Capacitance measured with a Boonton Meter or effective capacitance calculated from the equation: $C = I \Delta t / \Delta V$.

16M FAMILY AC OPERATING CONDITIONS AND CHARACTERISTICS

($V_{CC} = 3.3 \text{ V} \pm 0.3 \text{ V}$, $T_A = 0 \text{ to } 70^\circ\text{C}$, Unless Otherwise Noted)

ALL DEVICES: READ, WRITE, AND READ-WRITE CYCLES (See Notes 1, 2, 3, and 4)

Parameter	Symbol		MCM51x405C-60		MCM51x405C-70		Unit	Notes	
	Std	Alt	Min	Max	Min	Max			
Random Read or Write Cycle Time	t_{RELREL}	t_{RC}	104	—	124	—	ns		
Read-Write Cycle Time	t_{RELREL}	t_{RWC}	135	—	157	—	ns		
Access Time from \overline{RAS}	t_{RELVQ}	t_{RAC}	—	60	—	70	ns	8, 13, 14	
Access Time from \overline{CAS}	t_{CELQV}	t_{CAC}	—	17	—	20	ns	8, 13	
Access Time from Column Address	MCM516405CV MCM517405CV	t_{AVQV}	t_{AA}	—	30	—	35	ns	8, 14
Access Time from Precharge \overline{CAS}		t_{CEHQV}	t_{CPA}	—	35	—	40	ns	8
\overline{CAS} to Output in Low-Z		t_{CELQX}	t_{CLZ}	0	—	0	—	ns	8
Output Buffer and Turn-Off Delay		t_{CEHQZ}	t_{OFF}	0	15	0	15	ns	9
Transition Time (Rise and Fall)		t_T	t_T	1	50	1	50	ns	7
\overline{RAS} Precharge Time		t_{REHREL}	t_{RP}	40	—	50	—	ns	
\overline{RAS} Pulse Width		t_{RELREH}	t_{RAS}	60	10 k	70	10 k	ns	
\overline{RAS} Hold Time		t_{CELREH}	t_{RSH}	10	—	12	—	ns	
\overline{CAS} Hold Time		t_{RELCEH}	t_{CSH}	40	—	50	—	ns	
\overline{CAS} Precharge to \overline{RAS} Hold Time		t_{CEHREH}	t_{RHCP}	35	—	40	—	ns	
\overline{CAS} Pulse Width		t_{CELCEH}	t_{CAS}	10	10 k	12	10 k	ns	
\overline{RAS} to \overline{CAS} Delay Time		t_{RELCEL}	t_{RCD}	14	45	14	50	ns	13
\overline{RAS} to Column Address Delay Time		t_{RELAV}	t_{RAD}	12	30	12	35	ns	14
\overline{CAS} to \overline{RAS} Precharge Time		t_{CEHREL}	t_{CRP}	5	—	5	—	ns	
\overline{CAS} Precharge Time		t_{CEHCEL}	t_{CP}	10	—	12	—	ns	
Row Address Setup Time		t_{AVREL}	t_{ASR}	0	—	0	—	ns	
Row Address Hold Time		t_{RELAX}	t_{RAH}	10	—	10	—	ns	

NOTES:

- All voltages are referenced to V_{SS} .
- I_{CC1} , I_{CC3} , I_{CC4} , I_{CC6} depend on cycle rate.
- I_{CC1} , I_{CC4} depend on output loading. Specified values are obtained with the output open.
- Address can be changed once or less while $\overline{RAS} = V_{IL}$. In case of I_{CC4} , it can be changed once or less during an extended data out cycle (t_{PC}).
- An initial pause of 200 μs is required after power-up followed by 8 \overline{RAS} only refresh cycles before proper device operation is achieved. In case of using internal refresh counter, a minimum of 8 \overline{CAS} before \overline{RAS} refresh cycles instead of 8 \overline{RAS} only refresh cycles are required.
- AC measurements $t_T = 5.0 \text{ ns}$.
- $V_{IH}(\text{min})$ and $V_{IL}(\text{max})$ are reference levels for measuring timing of input signals. Transition times are measured between V_{IH} and V_{IL} .
- Measured with a load equivalent to 1 LVTTL load and 100 pF at $V_{OH} = 2 \text{ V}$ ($I_{OUT} = -2 \text{ mA}$), $V_{OL} = 0.8 \text{ V}$ ($I_{OUT} = +2 \text{ mA}$).
- $t_{OFF}(\text{max})$ and $t_{GZ}(\text{max})$ define the time at which the output achieves the open circuit condition and are not referenced to output voltage levels.
- Either t_{RCH} or t_{RRH} must be satisfied for a read cycle.
- These parameters are referenced to \overline{CAS} leading edge in early write cycles and to \overline{WRITE} leading edge in Read-Modify-Write cycles.
- t_{WCS} , t_{CWD} , t_{RWD} , t_{AWD} and t_{CPWD} are specified as reference points only. If $t_{WCS} \geq t_{WCS}(\text{min})$, the cycle is an early write cycle and the DQ pins remain high impedance throughout the entire cycle. If $t_{CWD} \geq t_{CWD}(\text{min})$, $t_{RWD} \geq t_{RWD}(\text{min})$, $t_{AWD} \geq t_{AWD}(\text{min})$, and $t_{CPWD} \geq t_{CPWD}(\text{min})$ (for extended data out cycle only), the cycle is a read-modify-write cycle and the DQ pins will contain the data read from the selected address. If neither of these conditions are met; delayed write or at access time and until \overline{CAS} or OE goes back to V_{IH} , DQ is indeterminate.
- Operation within the $t_{RCD}(\text{max})$ limit ensures that $t_{RAC}(\text{max})$ can be met. $t_{RCD}(\text{max})$ is specified as a reference point only. If t_{RCD} is greater than the specified $t_{RCD}(\text{max})$ limit, then access time is controlled exclusively by t_{CAC} .
- Operation within the $t_{RAD}(\text{max})$ limit ensures that $t_{RAC}(\text{max})$ can be met. $t_{RAD}(\text{max})$ is specified as a reference point only. If t_{RAD} is greater than the specified $t_{RAD}(\text{max})$, then access time is controlled exclusively by t_{AA} .

ALL DEVICES, READ, WRITE, AND READ-WRITE CYCLES (continued)

Parameter	Symbol		MCM51x405C-60		MCM51x405C-70		Unit	Notes
	Std	Alt	Min	Max	Min	Max		
Column Address Setup Time	t _{AVCEL}	t _{ASC}	0	—	0	—	ns	
Column Address Hold Time	t _{CELAX}	t _{CAH}	10	—	12	—	ns	
Column Address to $\overline{\text{RAS}}$ Lead Time	t _{AVREH}	t _{RAL}	30	—	35	—	ns	
Read Command Setup Time	t _{WHCEL}	t _{RCS}	0	—	0	—	ns	
Read Command Hold Time Referenced to $\overline{\text{CAS}}$	t _{CEHWX}	t _{RCH}	0	—	0	—	ns	10
Read Command Hold Time Referenced to $\overline{\text{RAS}}$	t _{REHWX}	t _{RRH}	0	—	0	—	ns	10
Write Command Hold Time Referenced to $\overline{\text{CAS}}$	t _{CELWH}	t _{WCH}	10	—	12	—	ns	
Write Command Pulse Width	t _{WLWH}	t _{WP}	10	—	12	—	ns	
Write Command to $\overline{\text{RAS}}$ Lead Time	t _{WLREH}	t _{RWL}	10	—	12	—	ns	
Write Command to $\overline{\text{CAS}}$ Lead Time	t _{WLCEH}	t _{CWL}	10	—	12	—	ns	
Data In Setup Time	t _{DVCEL}	t _{DS}	0	—	0	—	ns	11
Data In Hold Time	t _{CELDX}	t _{DH}	10	—	12	—	ns	11
Write Command Setup Time	t _{WLCEL}	t _{WCS}	0	—	0	—	ns	12
$\overline{\text{CAS}}$ to Write Delay	t _{CELWL}	t _{CWD}	36	—	39	—	ns	12
$\overline{\text{RAS}}$ to Write Delay	t _{RELWL}	t _{RWD}	79	—	89	—	ns	12
Column Address to Write Delay	t _{AVWL}	t _{AWD}	49	—	54	—	ns	12
Refresh Period	MCM516405CV MCM517405CV	t _{RVRV} t _{RFSH}	— —	64 32	— —	64 32	ms	
$\overline{\text{CAS}}$ Setup Time for $\overline{\text{CAS}}$ Before $\overline{\text{RAS}}$ Refresh	t _{RELCEL}	t _{CSR}	5	—	5	—	ns	
$\overline{\text{CAS}}$ Hold Time for $\overline{\text{CAS}}$ Before $\overline{\text{RAS}}$ Refresh	t _{RELCEH}	t _{CHR}	10	—	15	—	ns	
$\overline{\text{RAS}}$ Precharge to $\overline{\text{CAS}}$ Active Time	t _{REHCEL}	t _{RPC}	5	—	5	—	ns	
$\overline{\text{CAS}}$ Precharge Time for $\overline{\text{CAS}}$ Before $\overline{\text{RAS}}$ Counter Time	t _{CEHCEL}	t _{CPT}	20	—	20	—	ns	
Write Command Setup Time (Test Mode)	t _{WLREL}	t _{WTS}	10	—	10	—	ns	
Write Command Hold Time (Test Mode)	t _{RELWH}	t _{WTH}	10	—	10	—	ns	
Write to $\overline{\text{RAS}}$ Precharge Time ($\overline{\text{CAS}}$ Before $\overline{\text{RAS}}$ Refresh)	t _{WHREL}	t _{WRP}	10	—	10	—	ns	
Write to $\overline{\text{RAS}}$ Hold Time ($\overline{\text{CAS}}$ Before $\overline{\text{RAS}}$ Refresh)	t _{RELWL}	t _{WRH}	10	—	10	—	ns	

DEVICE-SPECIFIC AC OPERATING CONDITIONS AND CHARACTERISTICS

($V_{CC} = 3.3 \text{ V} \pm 0.3 \text{ V}$, $T_A = 0 \text{ to } 70^\circ\text{C}$, Unless Otherwise Noted)

4M x 4 CONFIGURATION-SPECIFIC READ, WRITE, AND READ-WRITE CYCLES (See Notes 1, 2, 3, and 4)

Parameter	Symbol		MCM51x405C-60		MCM51x405C-70		Unit	Notes
	Std	Alt	Min	Max	Min	Max		
$\overline{\text{RAS}}$ Hold Time Referenced to $\overline{\text{G}}$	t_{GLREH}	t_{ROH}	10	—	10	—	ns	
$\overline{\text{G}}$ Access Time	t_{GLQV}	t_{GA}	—	15	—	20	ns	5
$\overline{\text{G}}$ to Data Delay	t_{GLHDX}	t_{GD}	15	—	15	—	ns	6
Output Buffer Turn-Off Delay Time from $\overline{\text{G}}$	t_{GHQZ}	t_{GZ}	0	15	0	15	ns	
$\overline{\text{G}}$ Command Hold Time	t_{WLGL}	t_{GH}	10	—	12	—	ns	
Output Disable Setup Time	t_{GHCEL}	t_{GDS}	0	—	0	—	ns	

NOTES:

- V_{IH} (min) and V_{IL} (max) are reference levels for measuring timing of input signals. Transition times are measured between V_{IH} and V_{IL} .
- An initial pause of 200 μs is required after power-up followed by 8 $\overline{\text{RAS}}$ cycles before proper device operation is guaranteed.
- The transition time specification applies for all input signals. In addition to meeting the transition rate specification, all input signals must transition between V_{IH} and V_{IL} (or between V_{IL} and V_{IH}) in a monotonic manner.
- AC measurements $t_T = 5.0 \text{ ns}$.
- Measured with a load equivalent to 1 LVTTTL load and 100 pF at $V_{\text{OH}} = 2 \text{ V}$ ($I_{\text{OUT}} = -2 \text{ mA}$); $V_{\text{OL}} = 0.8 \text{ V}$ ($I_{\text{OL}} = +2 \text{ mA}$).
- t_{OFF} (max) and/or t_{GZ} (max) define the time at which the output achieves the open circuit condition and is not referenced to output voltage levels.

EXTENDED DATA OUT MODE ELECTRICAL CHARACTERISTICS AND RECOMMENDED AC OPERATING CONDITIONS

(See Notes 1 through 5)

Parameter	Symbol		MCM51x405C-60		MCM51x405C-70		Unit	Notes
	Std	Alt	Min	Max	Min	Max		
$\overline{\text{RAS}}$ to next $\overline{\text{CAS}}$ Delay Time (EDO mode)	t_{RELCEL}	t_{RNCD}	60	—	70	—	ns	
Extended Data Out Cycle Time	t_{EPC}	t_{EC}	25	—	30	—	ns	
Extended Data Out Read-Modify-Write Cycle Time	t_{CELCEL}	t_{ERWC}	68	—	75	—	ns	
Output Data Hold Time	t_{CELQZ}	t_{COH}	5	—	5	—	ns	
Output Buffer Turn-Off Delay from $\overline{\text{RAS}}$	t_{REHQZ}	t_{REZ}	0	15	0	15	ns	
Output Buffer Turn-Off Delay from $\overline{\text{W}}$	t_{WLQZ}	t_{WEZ}	0	15	0	15	ns	
$\overline{\text{W}}$ to Data Delay	t_{WLDZ}	t_{WED}	15	—	15	—	ns	
$\overline{\text{G}}$ Pulse Width	t_{GLGH}	t_{G}	15	—	20	—	ns	
$\overline{\text{G}}$ Precharge Time	t_{GHGL}	t_{GP}	10	—	12	—	ns	
$\overline{\text{CAS}}$ to $\overline{\text{G}}$ Precharge Time	t_{CEHGL}	t_{CPG}	5	—	5	—	ns	

NOTES:

- V_{IH} (min) and V_{IL} (max) are reference levels for measuring timing of input signals. Transition times are measured between V_{IH} and V_{IL} .
- An initial pause of 200 μs is required after power-up followed by 8 $\overline{\text{RAS}}$ cycles before proper device operation is guaranteed.
- The transition time specification applies for all input signals. In addition to meeting the transition rate specification, all input signals must transition between V_{IH} and V_{IL} (or between V_{IL} and V_{IH}) in a monotonic manner.
- AC measurements $t_T = 5.0 \text{ ns}$.
- t_{WCS} , t_{RWD} , t_{CWD} , t_{AWD} , and t_{CPWD} are not restrictive operating parameters. They are included in the data sheet as electrical characteristics only; if $t_{\text{WCS}} \geq t_{\text{WCS}}(\text{min})$, the cycle is an early write cycle and the data out pin will remain open circuit (high impedance) through-out the entire cycle; if $t_{\text{CWD}} \geq t_{\text{CWD}}(\text{min})$, $t_{\text{RWD}} \geq t_{\text{RWD}}(\text{min})$, $t_{\text{AWD}} \geq t_{\text{AWD}}(\text{min})$, and $t_{\text{CPWD}} \geq t_{\text{CPWD}}(\text{min})$ (page mode), the cycle is a read-write cycle and the data out will contain data read from the selected cell. If neither of these sets of conditions is satisfied, the condition of the data out (at access time) is indeterminate.

TIMING DIAGRAMS

READ CYCLE

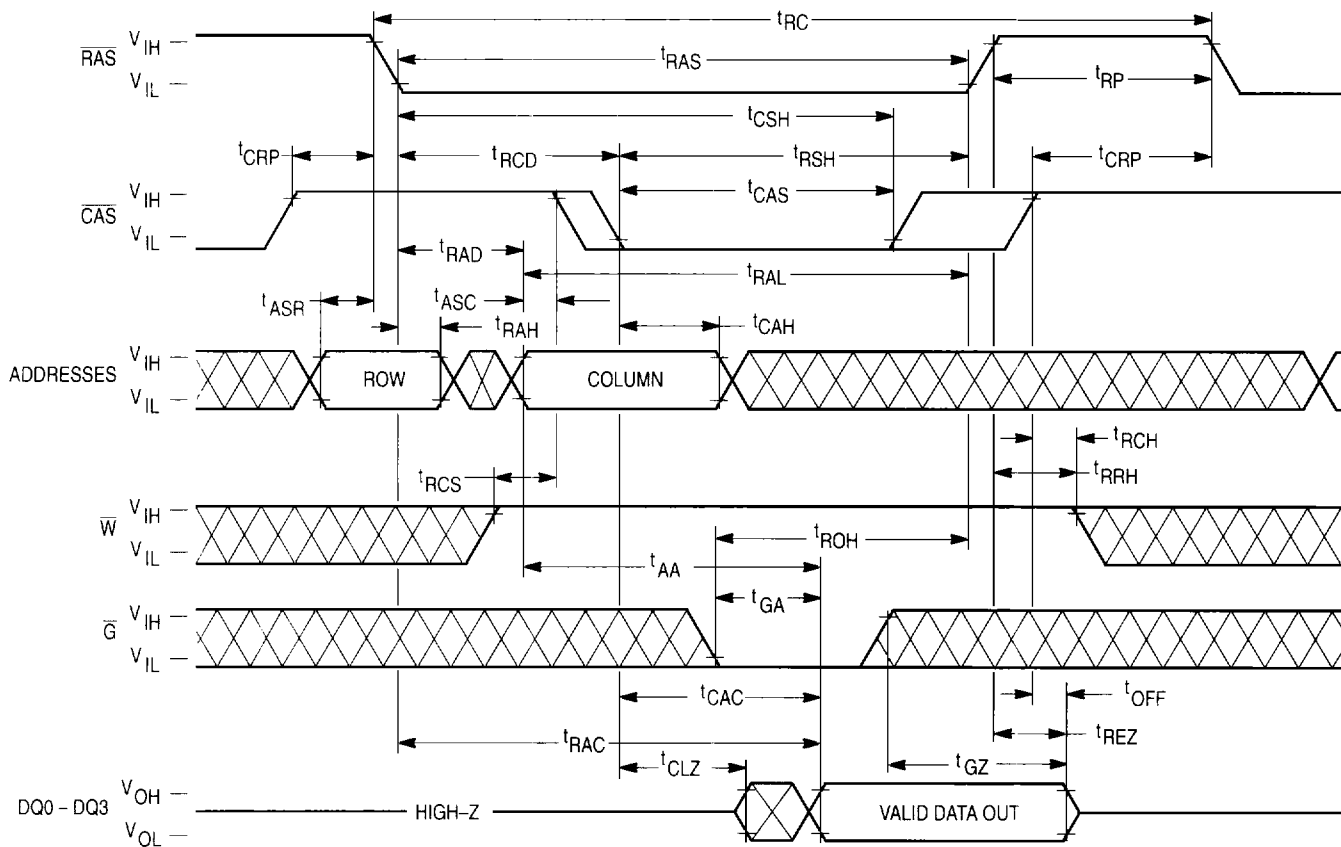

WRITE CYCLE (EARLY WRITE)

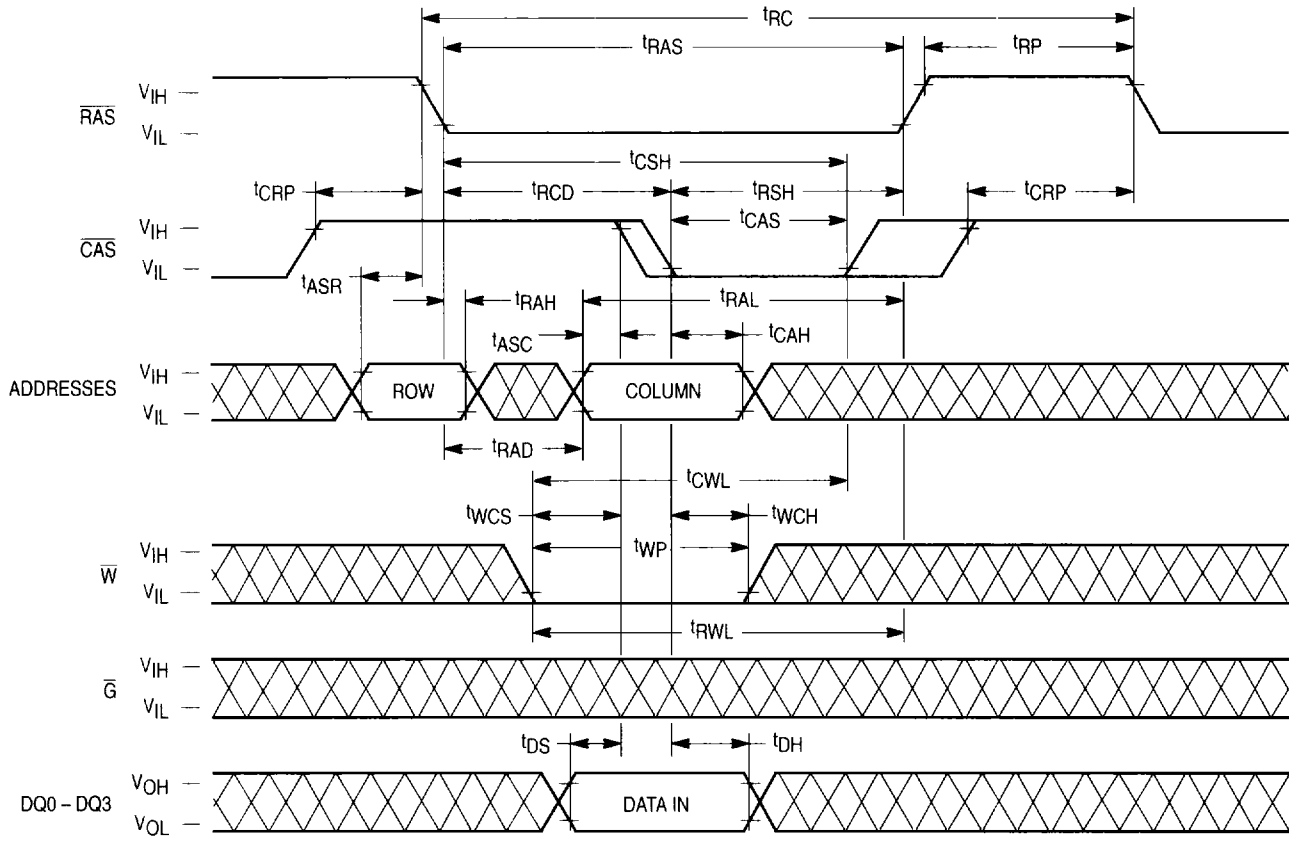

WRITE CYCLE (\bar{G} CONTROLLED WRITE)

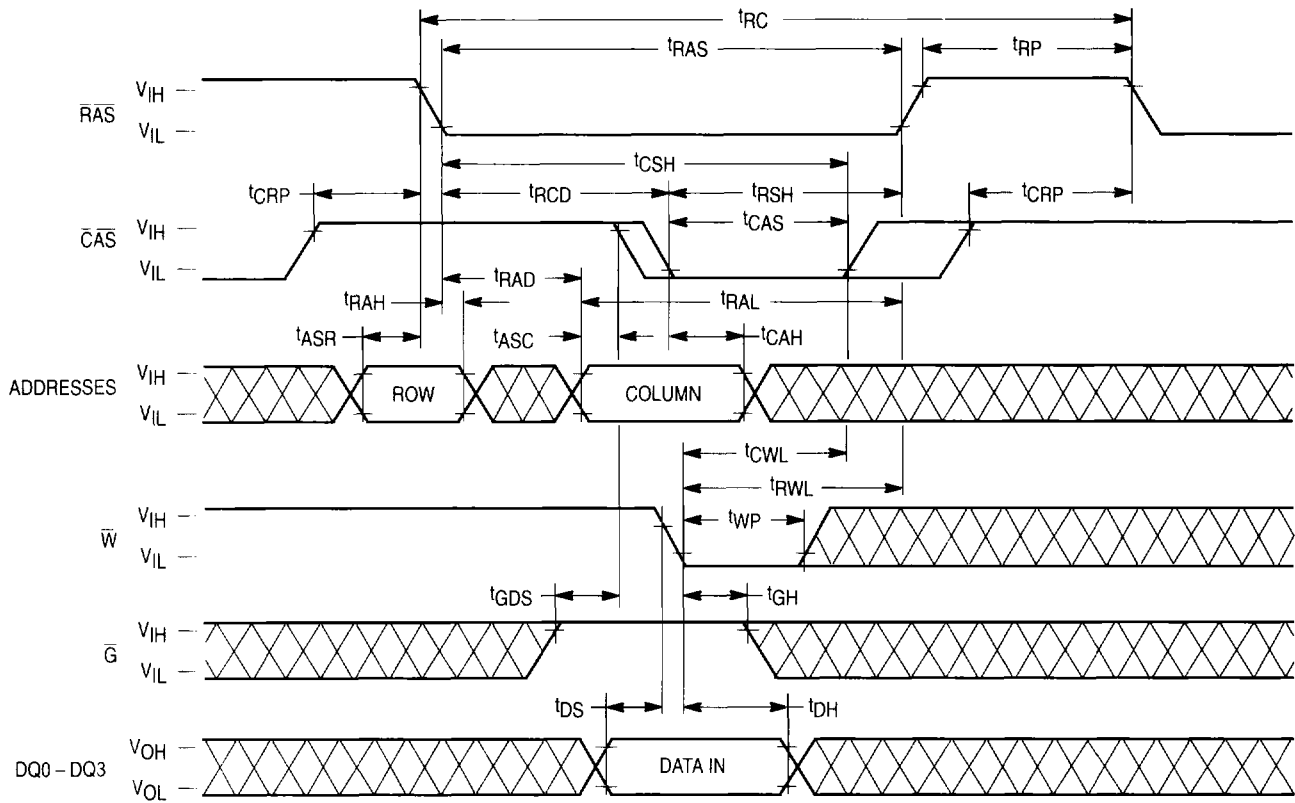

READ-WRITE CYCLE

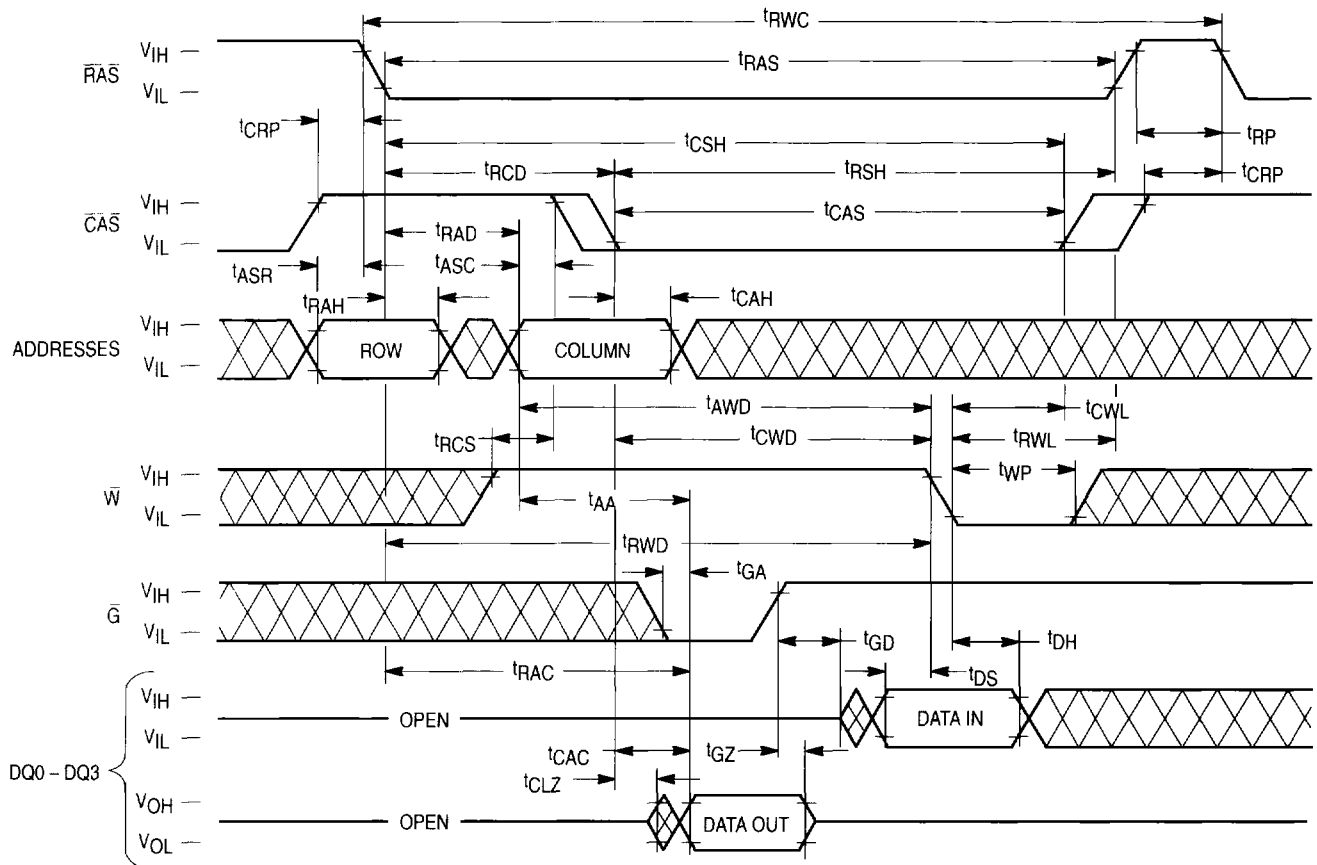

EXTENDED DATA OUT WRITE CYCLE (EARLY WRITE)

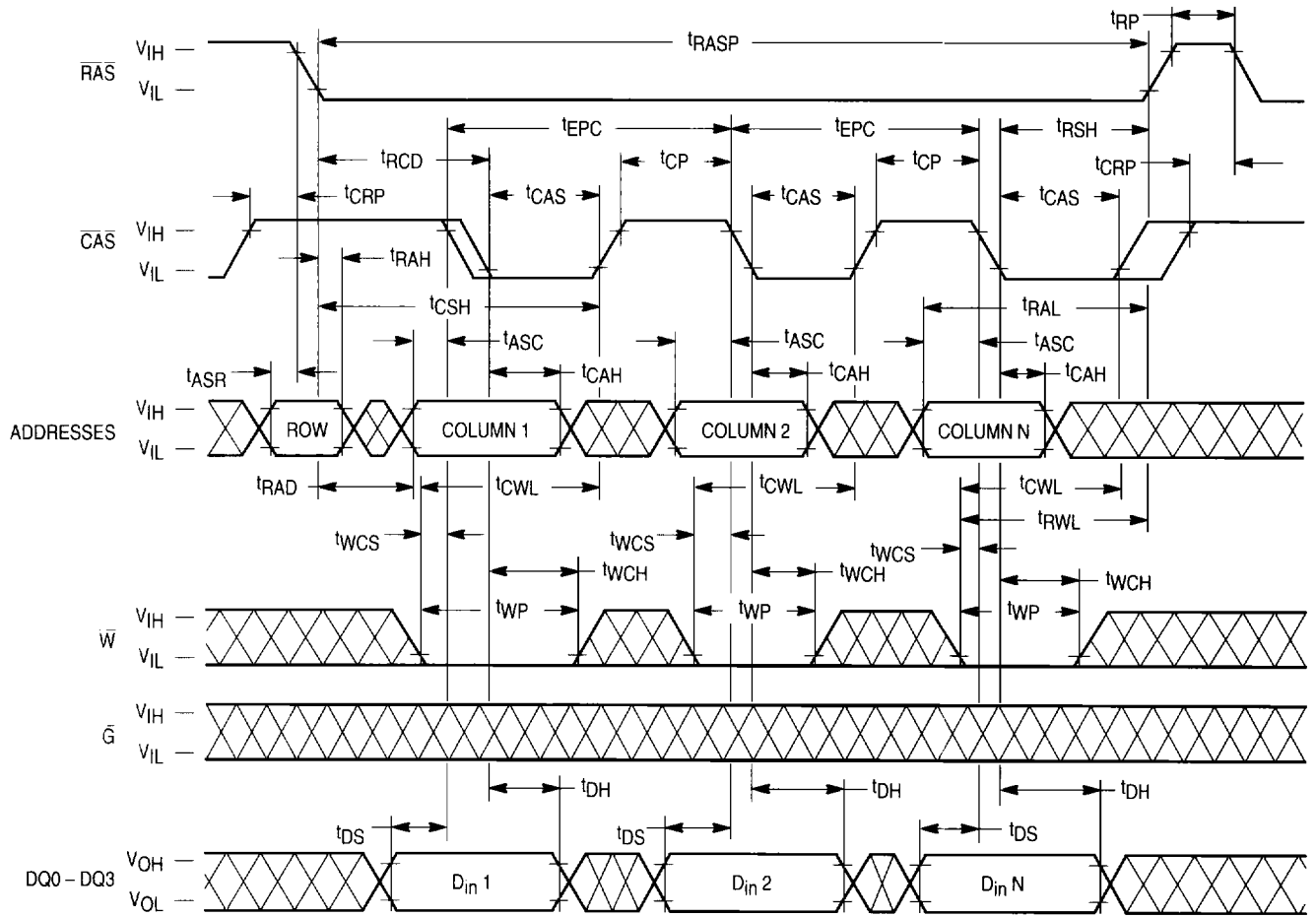

RAS-ONLY REFRESH CYCLE

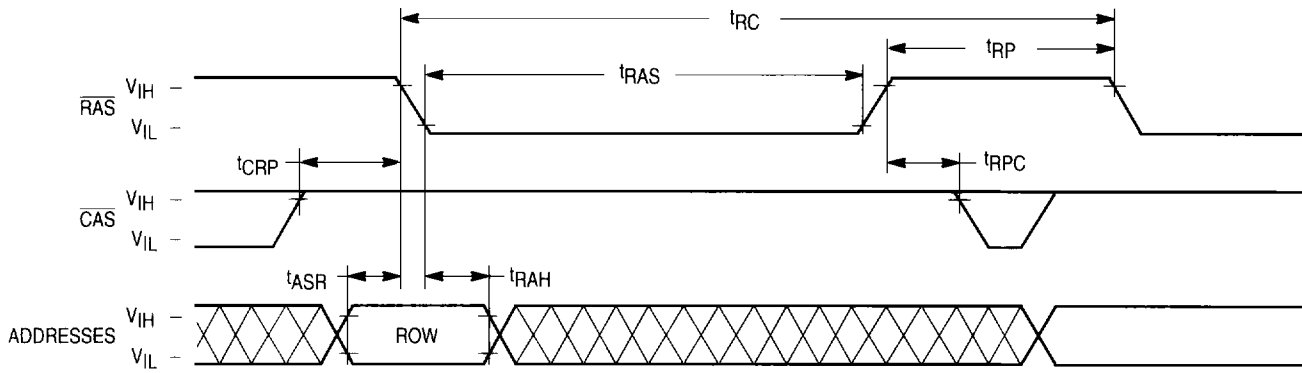

NOTE: $\bar{W}, \bar{G} = H$ or L
 DQ0 - DQ3 = Open

CAS BEFORE RAS REFRESH CYCLE

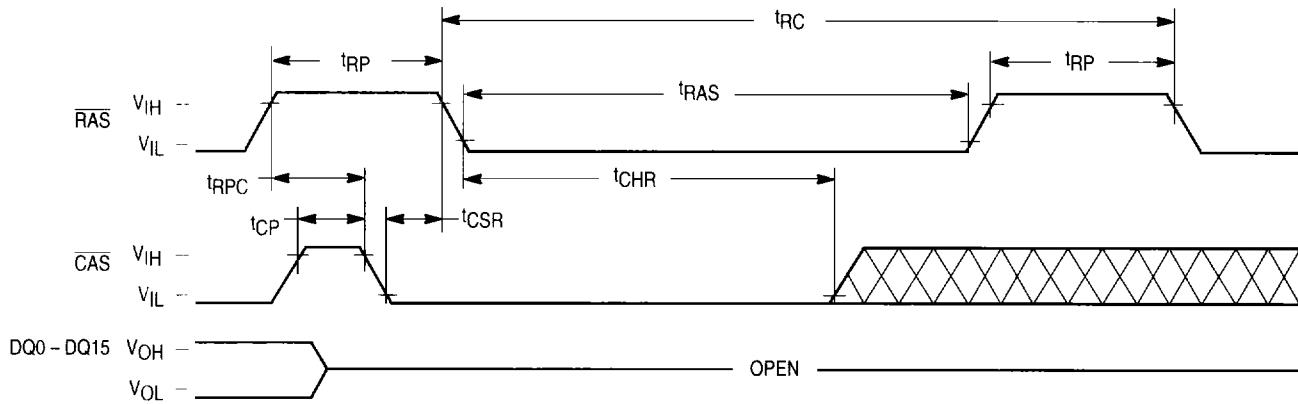

NOTE: $\bar{W}, \bar{G}, \text{Addresses} = H$ or L

HIDDEN REFRESH CYCLE (READ)

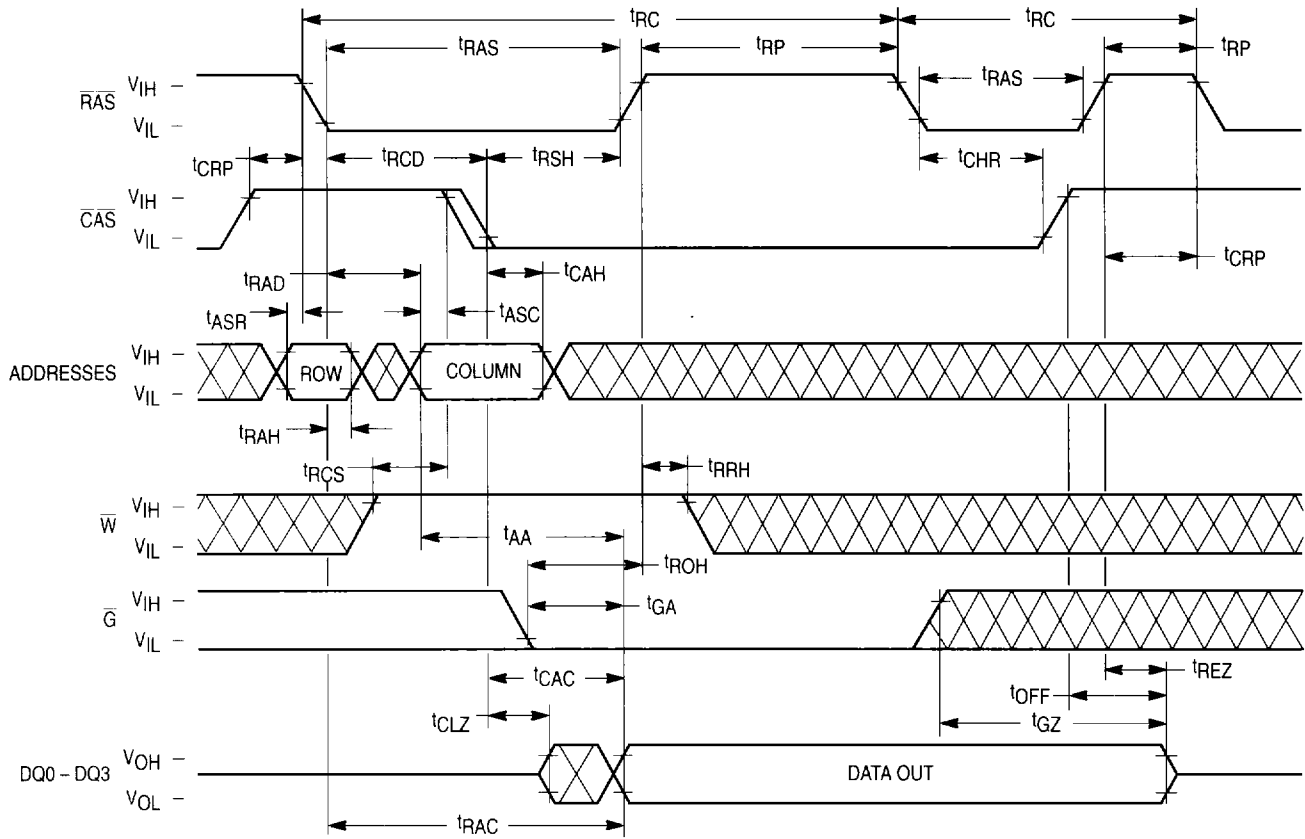

HIDDEN REFRESH CYCLE (WRITE)

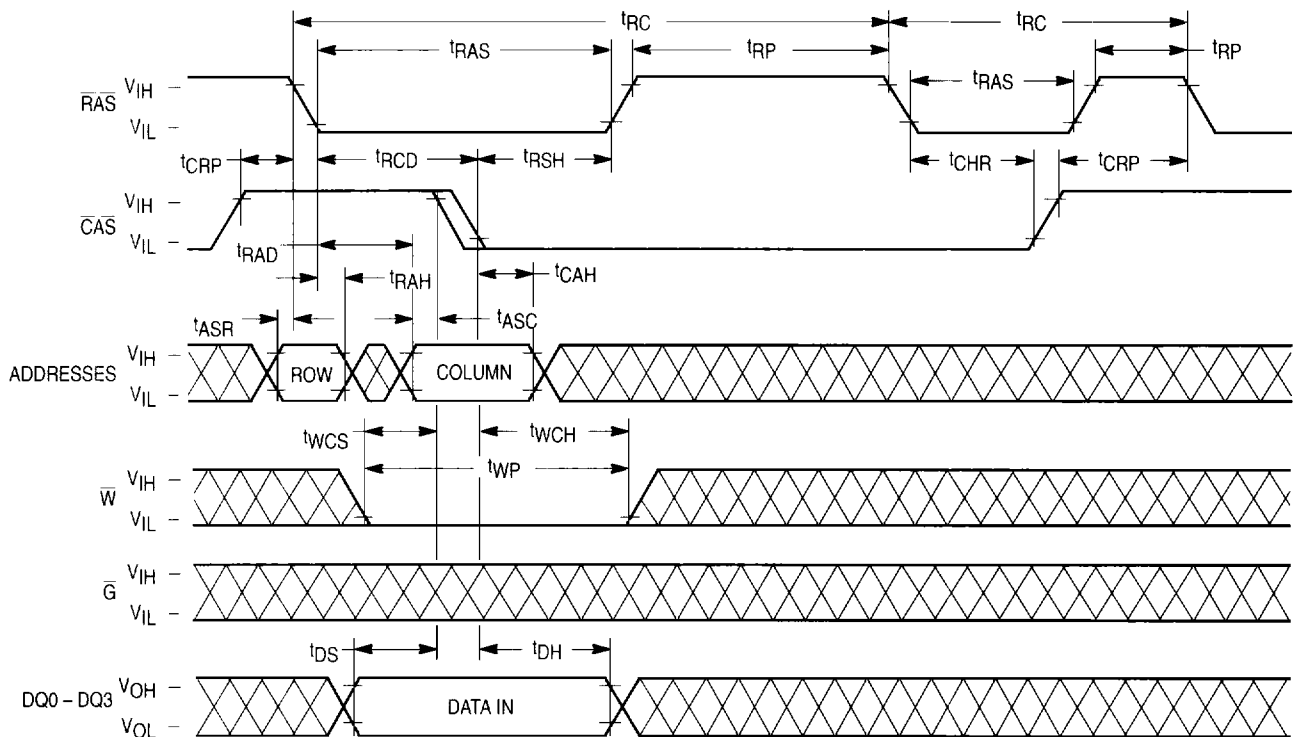

CAS BEFORE RAS REFRESH COUNTER TEST READ CYCLE

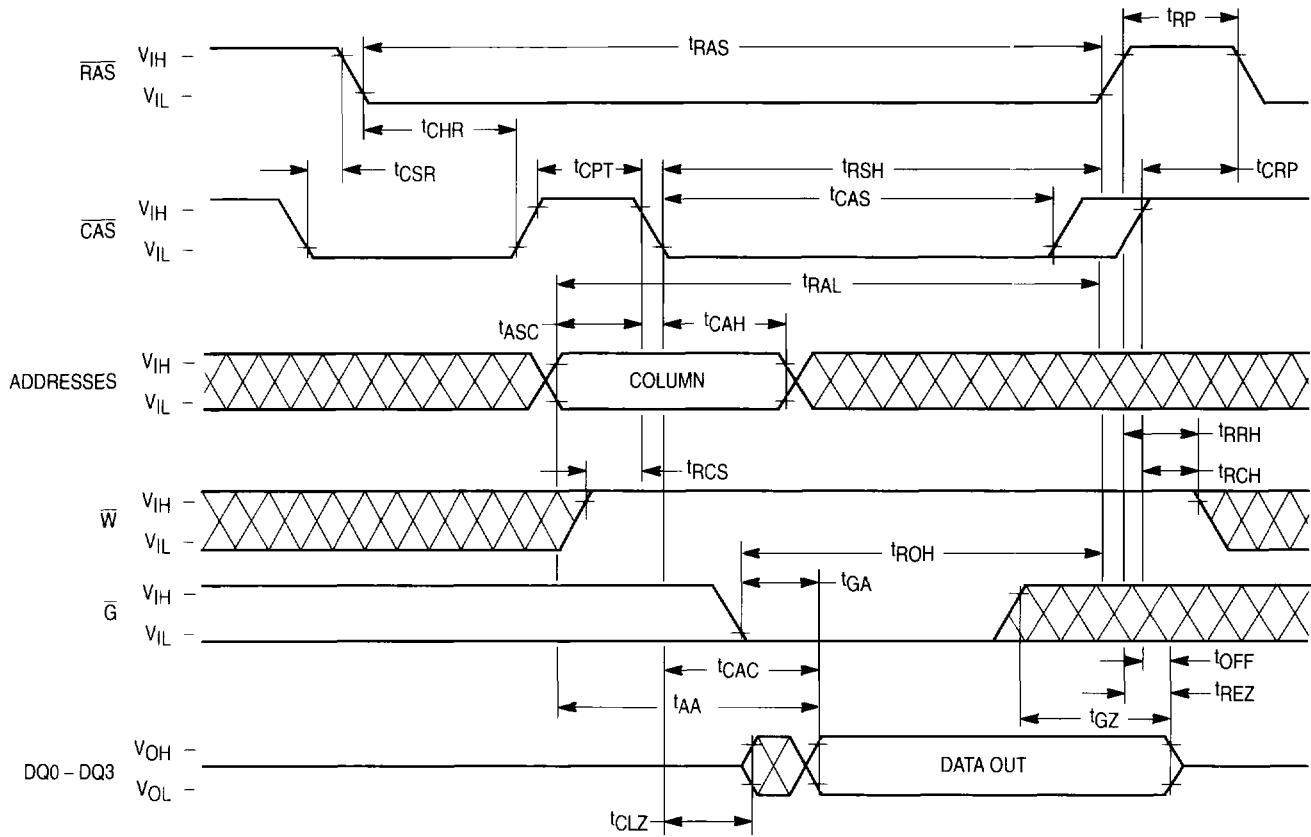

CAS BEFORE RAS REFRESH COUNTER TEST WRITE CYCLE

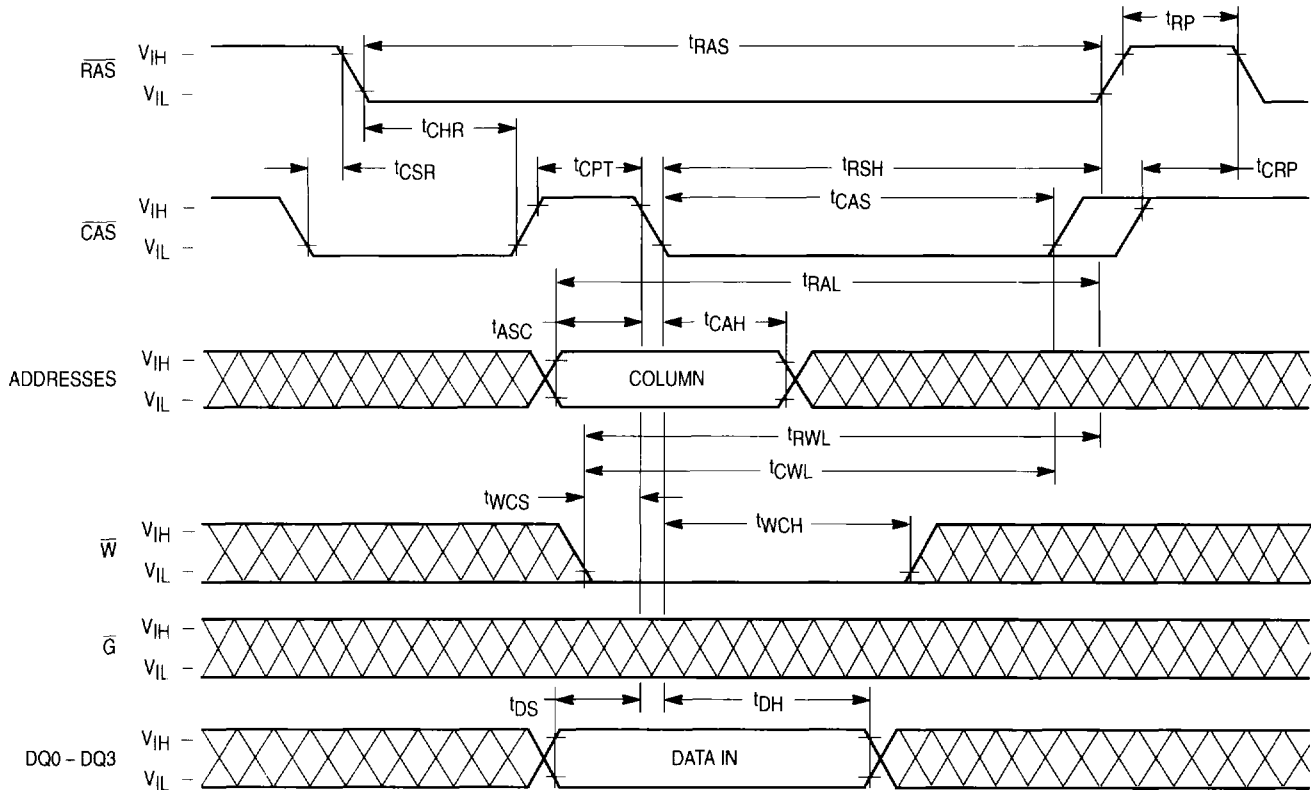

CAS BEFORE RAS REFRESH COUNTER TEST READ-WRITE CYCLE

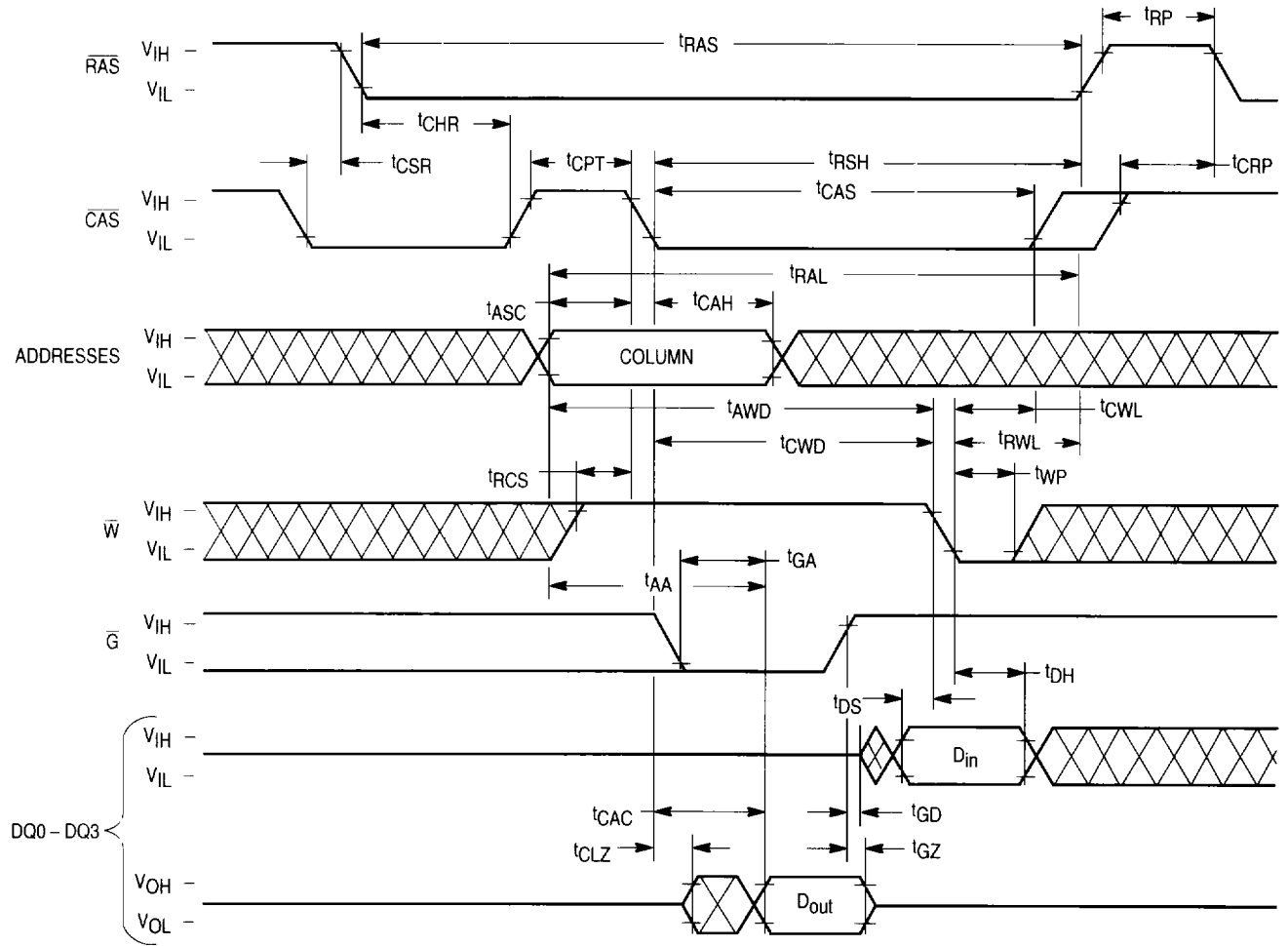

DEVICE INITIALIZATION

On power-up, an initial pause of 200 microseconds is required for the internal substrate generator to establish the correct bias voltage. This must be followed by a minimum of eight active cycles of the row address strobe (clock) to initialize all dynamic nodes within the RAM. During an extended inactive state (greater than 32 milliseconds or 64 milliseconds, for MCM517405CV and MCM516405CV, respectively), a wakeup sequence of eight active cycles is necessary to ensure proper operation.

ADDRESSING THE RAM

MCM516405CV: The twelve address pins on the device are time multiplexed at the beginning of a memory cycle by two clocks, row address strobe (\overline{RAS}) and column address strobe (\overline{CAS}), into two separate address fields. A total of twenty two address bits, twelve rows and ten columns, will decode one of the 4,194,304 four bit word locations in the device. \overline{RAS} active transition is followed by \overline{CAS} active transition (active = V_{IL} , t_{RCD} minimum) for all read or write cycles. The delay between \overline{RAS} and \overline{CAS} active transitions, referred to as the **multiplex window**, gives a system designer flexibility in setting up the external addresses into the RAM.

The external \overline{CAS} signal is ignored until an internal \overline{RAS} signal is available. This "gate" feature on the external \overline{CAS} clock enables the internal \overline{CAS} line as soon as the row address hold time (t_{RAH}) specification is met (and defines t_{RCD} minimum). The multiplex window can be used to absorb skew delays in switching the address bus from row to column addresses and in generating the \overline{CAS} clock.

MCM517405CV: The eleven address pins on the device are time multiplexed at the beginning of a memory cycle by two clocks, row address strobe (\overline{RAS}) and column address strobe (\overline{CAS}), into two separate 11-bit address fields. A total of twenty two address bits, eleven rows and eleven columns, will decode one of the 4,194,304 four bit word locations in the device. \overline{RAS} active transition is followed by \overline{CAS} active transition (active = V_{IL} , t_{RCD} minimum) for all read or write cycles. The delay between \overline{RAS} and \overline{CAS} active transitions, referred to as the **multiplex window**, gives a system designer flexibility in setting up the external addresses into the RAM.

The external \overline{CAS} signal is ignored until an internal \overline{RAS} signal is available. This "gate" feature on the external \overline{CAS} clock enables the internal \overline{CAS} line as soon as the row address hold time (t_{RAH}) specification is met (and defines t_{RCD} minimum). The multiplex window can be used to absorb skew delays in switching the address bus from row to column addresses and in generating the \overline{CAS} clock.

There are three other variations in addressing the 16M DRAM Family per device: \overline{RAS} -only refresh cycle, \overline{CAS} before \overline{RAS} refresh cycle, and page mode. All are discussed in separate sections that follow.

READ CYCLE

The DRAM may be read with four different cycles: "normal" random read cycle, extended data out read cycle, read-write cycle, and extended data out read-write cycle. The normal read cycle is outlined here, while the other cycles are discussed in separate sections.

The normal read cycle begins as described in **ADDRESSING THE RAM**, with \overline{RAS} and \overline{CAS} active transitions latching the desired bit location. The write (\overline{W}) input level must be high (V_{IH}), t_{RCS} (minimum) before the \overline{CAS} or active transition, to enable read mode.

Both the \overline{RAS} and \overline{CAS} clocks trigger a sequence of events that are controlled by several delayed internal clocks. The internal clocks are linked in such a manner that the read access time of the device is independent of the address multiplex window.

For **MCM516405CV and MCM517405CV**, both \overline{CAS} and output enable (\overline{G}) control read access time: \overline{CAS} must be active before or at t_{RCD} maximum and \overline{G} must be active $t_{RAC}-t_{GA}$ (both minimum) after \overline{RAS} active transition to guarantee valid data out (Q) at t_{RAC} . If the t_{RCD} maximum is exceeded and/or \overline{G} active transition does not occur in time, read access time is determined by either the \overline{CAS} or \overline{G} clock active transition (t_{CAC} or t_{GA}).

WRITE CYCLE

The user can write to the DRAM with any of four cycles: early write, late write, extended data out early write, and extended data out read-write. Early and late write modes are discussed here, while extended data out write operation is covered in a separate section.

A write cycle begins as described in **ADDRESSING THE RAM**. Write mode is enabled by the transition of \overline{W} to active (V_{IL}). Early and late write modes are distinguished by the active transition of \overline{W} , with respect to \overline{CAS} . Minimum active time t_{RAS} and t_{CAS} , and precharge time t_{RP} , apply to write mode, as in the read mode.

An early write cycle is characterized by \overline{W} active transition at minimum time t_{WCS} before \overline{CAS} active transition. Column address setup and hold times (t_{ASC} , t_{CAH}) and data in (D) setup and hold times (t_{DS} , t_{DH}) are referenced to \overline{CAS} in an early write cycle. \overline{RAS} and \overline{CAS} clocks must stay active for t_{RWL} and t_{CWL} , respectively, after the start of the early write operation to complete the cycle.

A late-write cycle (referred to as \overline{G} -controlled write) occurs when \overline{W} active transition is made after \overline{CAS} active transition. \overline{W} active transition could be delayed for almost 10 microseconds after \overline{CAS} active transition, ($t_{RCD} + t_{CWD} + t_{RWL} + 2t_T$) $\leq t_{RAS}$, if other timing minimums (t_{RCD} , t_{RWL} , and t_T) are maintained. D timing parameters are referenced to \overline{W} active transition in a late write cycle. Output buffers are enabled by \overline{CAS} active transition. 4M x 4 outputs are switched off by \overline{G} inactive transition, which is required to write to the device. Q may be indeterminate (see note 12 of AC Operating Conditions table). \overline{RAS} and \overline{CAS} must remain active for t_{RWL} and t_{CWL} , respectively, after \overline{W} active transition to complete the write cycle. \overline{G} (4M x 4) devices must remain inactive for t_{GH} after \overline{W} active transition to complete the write cycle.

READ-WRITE CYCLE

A read-write cycle performs a read and then a write at the same address, during the same cycle. This cycle is basically a late write cycle, as discussed in the **WRITE CYCLE** section, except \overline{W} must remain high for t_{CWD} and/or t_{AWD} minimum, to guarantee valid Q before writing the bit.

PAGE MODE CYCLES

Page mode allows fast successive data operations at all column locations (MCM516405CV: 1024 columns; and MCM517405CV: 2048 columns) on a selected row of the 16M DRAM family. Read access time in page mode (t_{CAC}) is typically half the regular \overline{RAS} clock access time, t_{RAC} . Page mode operation consists of keeping \overline{RAS} active while toggling \overline{CAS} between V_{IH} and V_{IL} . The row is latched by \overline{RAS} active transition, while each \overline{CAS} active transition allows selection of a new column location on the row.

A page mode cycle is initiated by a normal read, write, or read–write cycle, as described in prior sections. Once the timing requirements for the first cycle are met, \overline{CAS} transitions to inactive for minimum t_{CP} , while \overline{RAS} remains low (V_{IL}). The second \overline{CAS} active transition while \overline{RAS} is low initiates the first page mode cycle (t_{PC} or t_{PRWC}). Either a read, write, or read–write operation can be performed in a page mode cycle, subject to the same conditions as in normal operation (previously described). These operations can be intermixed in consecutive page mode cycles and performed in any order. The maximum number of consecutive page mode cycles is limited by t_{RASP} . Page mode operation is ended when \overline{RAS} transitions to inactive, coincident with or following \overline{CAS} inactive transition.

REFRESH CYCLES

The dynamic RAM design is based on capacitor charge storage for each bit in the array. This charge will tend to degrade with time and temperature. Each bit must be periodically **refreshed** (recharged) to maintain the correct bit state. Bits in the MCM516405CV require refresh every 64 milliseconds, while refresh time for the MCM517405CV is 32 milliseconds.

This is accomplished by cycling through the 4096 and 2048 row addresses in sequence within the specified refresh time. All the bits on a row are refreshed simultaneously when the row is addressed. Distributed refresh implies a row refresh every 15.6 microseconds for the 16M DRAM device family. Burst refresh, a refresh of all rows consecutively, must be performed every 64 milliseconds on the MCM516405CV, and 32 milliseconds on the MCM517405CV.

A normal read, write, or read–write operation to the RAM will refresh all the bits (4096 or 2048) associated with the particular row decodes. Three other methods of refresh, **RAS–only refresh**, **\overline{CAS} before \overline{RAS} refresh**, and **hidden refresh** are available on this device for greater system flexibility.

RAS–Only Refresh

RAS–only refresh consists of \overline{RAS} transition to active, latching the row address to be refreshed, while \overline{CAS} remains high (V_{IH}) throughout the cycle. An external counter should be employed to ensure that all rows are refreshed within the specified limit.

\overline{CAS} Before \overline{RAS} Refresh

\overline{CAS} before \overline{RAS} refresh is enabled by bringing \overline{CAS} active before \overline{RAS} . This clock order activates an internal refresh counter that generates the row address to be refreshed. External address lines are ignored during the automatic refresh

cycle. The output buffer remains at the same state it was in during the previous cycle (hidden refresh). \overline{W} must be inactive for time t_{WRP} before and time t_{WRH} after \overline{RAS} active transition to prevent switching the device into a **test mode cycle**.

Hidden Refresh

Hidden refresh allows refresh cycles to occur while maintaining valid data at the output pin. Holding \overline{CAS} active at the end of a read or write cycle while \overline{RAS} cycles inactive for t_{RP} and back to active starts the hidden refresh. This is essentially the execution of a \overline{CAS} before \overline{RAS} refresh from a cycle in progress (see Figure 1). \overline{W} is subject to the same conditions with respect to \overline{RAS} active transition (to prevent test mode entry) as in \overline{CAS} before \overline{RAS} refresh.

\overline{CAS} BEFORE \overline{RAS} REFRESH COUNTER TEST

The internal refresh counter of this device can be tested with a **\overline{CAS} before \overline{RAS} refresh counter test**. This test is performed with a read–write operation. During the test, the internal refresh counter generates the row address, while the external address supplies the column address. The entire array is refreshed after 4096 or 2048 cycles, as indicated by the check data written in each row. See **\overline{CAS} before \overline{RAS} refresh counter test cycle timing diagram**.

The test can be performed after a minimum of eight **\overline{CAS} before \overline{RAS}** initialization cycles. Test procedure:

1. Write 0s into all memory cells with normal write mode.
2. Select a column address, read 0 out and write 1 into the cell by performing the **\overline{CAS} before \overline{RAS} refresh counter test, read–write cycle**. Repeat this operation 4096 or 2048 times, depending on device type.
3. Read the 1s that were written in step two in normal read mode.
4. Using the same starting column address as in step two, read 1 out and write 0 into the cell by performing the **\overline{CAS} before \overline{RAS} refresh counter test, read–write cycle**. Repeat this operation 4096 or 2048 times, depending on device type.
5. Read 0s which were written in step four in normal read mode.
6. Repeat steps one through five using complement data.

TEST MODE

The internal organization of the MCM516405CV and MCM517405CV allows the device to be tested as if it were a 1M x 16 DRAM. In **Test Mode** operation, column addresses A1 and A0 are ignored. A test mode cycle reads and/or writes data to a bit in each of the sixteen 1M blocks in parallel. During a write cycle, data is written using only DQ0, while during a read cycle, if all 16 bits are equal (all 0s or all 1s), DQ3 will indicate a 1. Otherwise, DQ3 will indicate a 0. DQ0, DQ1, and DQ2 always indicate a 1 during test mode read cycle. See Test Mode block diagram.

\overline{W} , \overline{CAS} before \overline{RAS} timing puts the device in **Test Mode**, as shown in the test mode timing diagram. A **\overline{CAS} before \overline{RAS} refresh cycle** or a **\overline{RAS} only refresh cycle** places the device back in normal mode. Refresh is performed in test mode by using a **\overline{W} , \overline{CAS} before \overline{RAS} refresh cycle** which uses the internal refresh address counter.

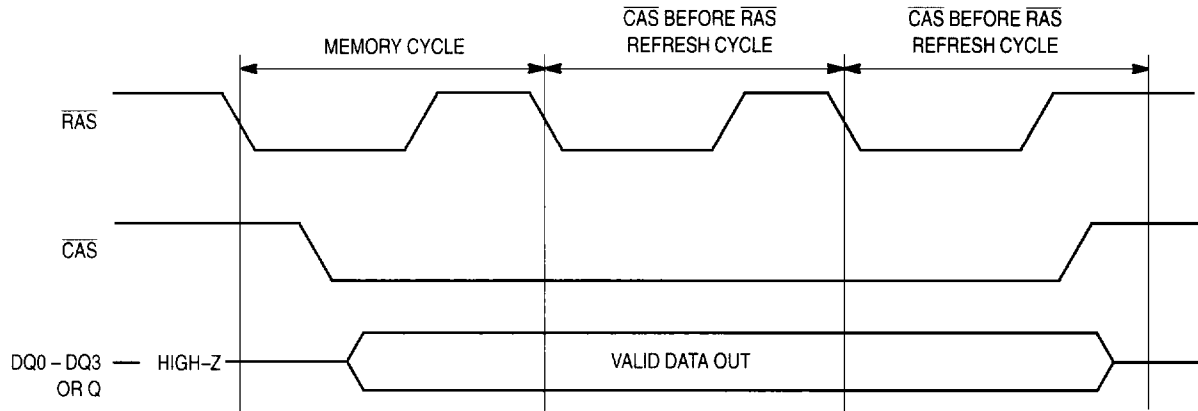

Figure 1. Hidden Refresh Cycle

TEST MODE AC OPERATING CONDITIONS AND CHARACTERISTICS

($V_{CC} = 5.0\text{ V} \pm 10\%$, $T_A = 0\text{ to }70^\circ\text{C}$, Unless Otherwise Noted)

READ, WRITE, AND READ-WRITE CYCLES

Parameter	Symbol		MCM51x405C-60		MCM51x405C-70		Unit	Notes
	Std	Alt	Min	Max	Min	Max		
Random Read or Write Cycle Time	t_{RELREL}	t_{RC}	109	—	129	—	ns	
Extended Data Out Cycle Time	t_{EPC}	t_{EC}	30	—	35	—	ns	
Access Time from \overline{RAS}	t_{RELQV}	t_{RAC}	—	65	—	75	ns	1, 2, 3
Access Time from \overline{CAS}	t_{CELQV}	t_{CAC}	—	22	—	25	ns	1, 2
Access Time from Column Address	t_{AVQV}	t_{AA}	—	35	—	40	ns	1, 3
Access Time from \overline{CAS} Precharge	t_{CEHQV}	t_{CPA}	—	40	—	45	ns	1
\overline{RAS} Pulse Width	t_{RELREH}	t_{RAS}	65	10 k	75	10 k	ns	
\overline{RAS} Pulse Width (Extended Data Out)	t_{RELREH}	t_{RASP}	65	200 k	75	200 k	ns	
\overline{RAS} Hold Time	t_{CELREH}	t_{RSH}	15	—	17	—	ns	
\overline{CAS} Hold Time	t_{RELCEH}	t_{CSH}	45	—	55	—	ns	
\overline{CAS} Precharge to \overline{RAS} Hold Time	t_{CEHREH}	t_{RHCP}	40	—	45	—	ns	
\overline{CAS} Pulse Width	t_{CELCEH}	t_{CAS}	15	10 k	17	10 k	ns	
Column Address to \overline{RAS} Lead Time	t_{AVREH}	t_{RAL}	35	—	40	—	ns	

NOTES:

1. Measured with a load equivalent to 2 TTL loads and 100 pF.
2. Operation within the $t_{RCD}(\text{max})$ limit ensures that $t_{RAC}(\text{max})$ can be met. $t_{RCD}(\text{max})$ is specified as a reference point only. If t_{RCD} is greater than the specified $t_{RCD}(\text{max})$ limit, then access time is controlled exclusively by t_{CAC} .
3. Operation within the $t_{RAD}(\text{max})$ limit ensures that $t_{RAC}(\text{max})$ can be met. $t_{RAD}(\text{max})$ is specified as a reference point only. If t_{RAD} is greater than the specified $t_{RAD}(\text{max})$, then access time is controlled exclusively by t_{AA} .

TEST MODE TIMING DIAGRAMS

WRITE OR CAS BEFORE RAS REFRESH CYCLE (TEST MODE ENTRY)

(\bar{G} and A0 – A10 or 11 are Don't Care)

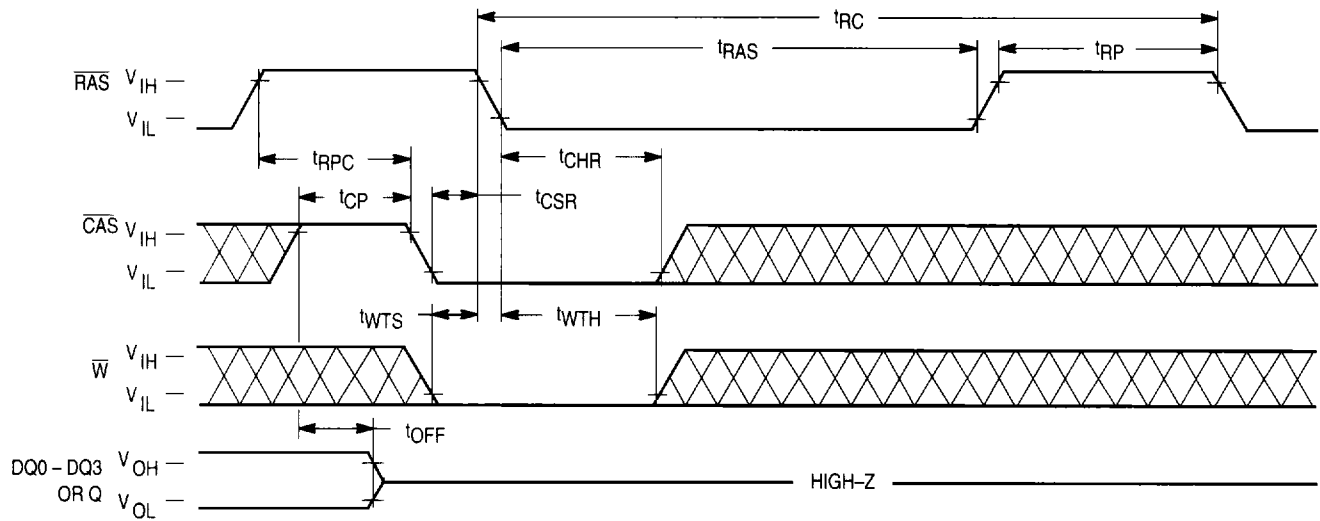

NOTE: Once the device is put into Test Mode with the Test Mode Entry Cycle, any of the standard cycles (Read, Write, Extended Data Out, etc.) may be used to test the part, providing that the timing parameters are modified as described in the Test Mode AC Operating Conditions and Characteristics table. The timing diagrams previously presented are valid for all cycles performed in Test Mode.

MODE DEPENDENT ON \bar{CAS} AND \bar{W} WHEN \bar{RAS} FALLS

Mode	\bar{CAS}	\bar{W}^*
Read, Write, RMW, FPM	1	0
CBR Refresh, Test Mode Exit	0	1
Test Mode Entry	0	0

*Logic state when \bar{RAS} transitions low.

**TEST MODE BLOCK DIAGRAM
(MCM516405CV, MCM517405CV)**

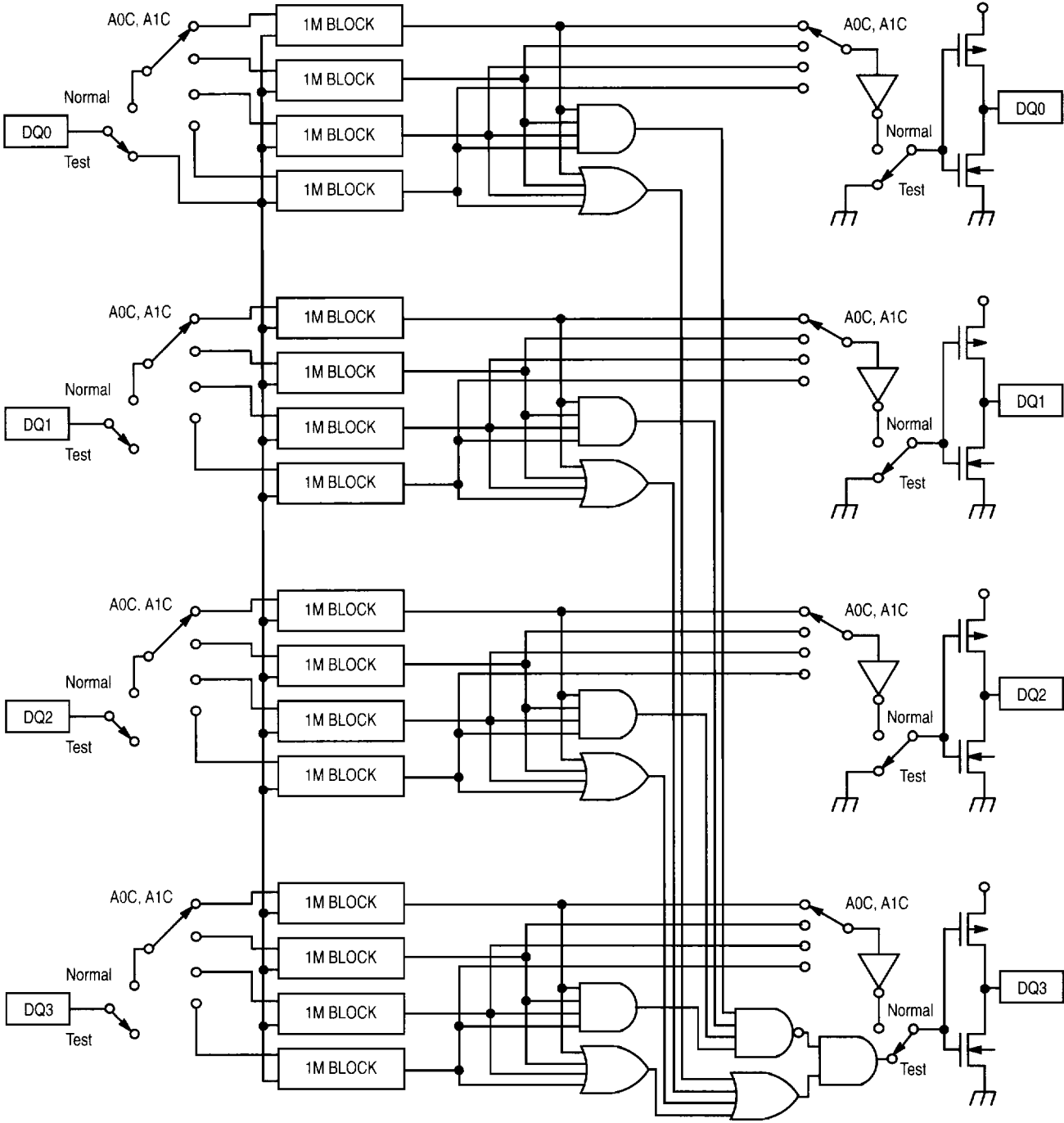

ORDERING INFORMATION
(Order by Full Part Number)

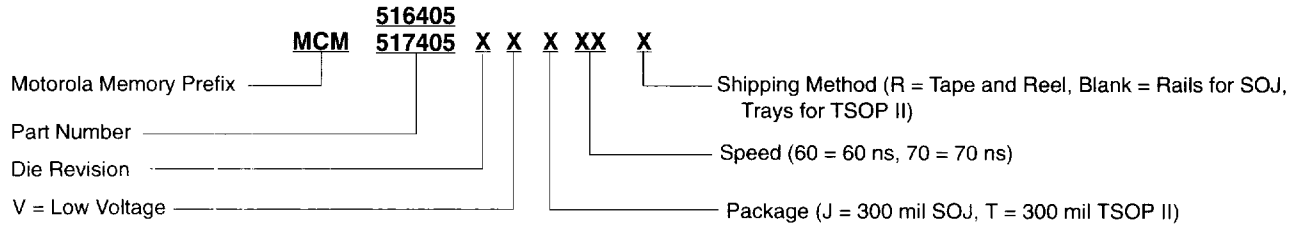

16M DEVICE NUMBERS

- | | | | |
|-----------------|-----------------|-----------------|-----------------|
| MCM516405CVJ60 | MCM517405CVJ60 | MCM516405CVT60 | MCM517405CVT60 |
| MCM516405CVJ70 | MCM517405CVJ70 | MCM516405CVT70 | MCM517405CVT70 |
| MCM516405CVJ60R | MCM517405CVJ60R | MCM516405CVT60R | MCM517405CVT60R |
| MCM516405CVJ70R | MCM517405CVJ70R | MCM516405CVT70R | MCM517405CVT70R |

PACKAGE DIMENSIONS

J PACKAGE
300 MIL SOJ
CASE 880A-02

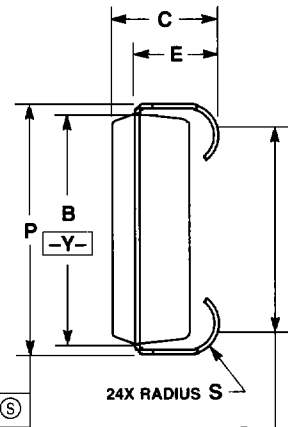
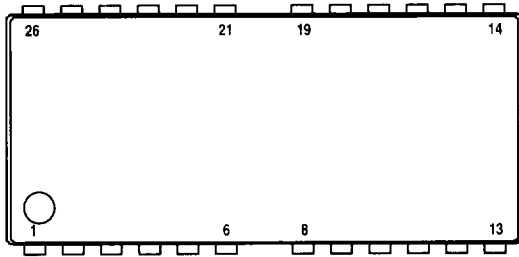

⊕ 0.007 (0.18) (M) T Y (S) Z (S)

⊕ 0.007 (0.18) (M) T Y (S) Z (S)

NOTE 3

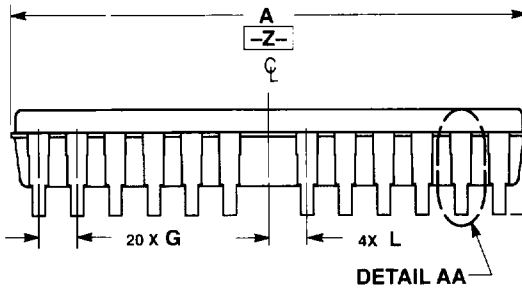

0.004 (0.100)
-T- SEATING PLANE

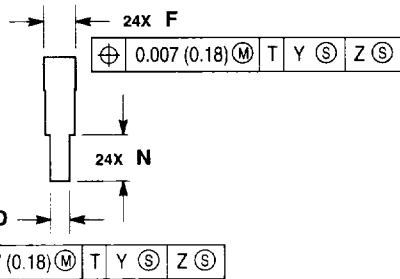

⊕ 0.007 (0.18) (M) T Y (S) Z (S)

NOTE 3
DETAIL AA

NOTES:

- DIMENSIONING AND TOLERANCING PER ANSI Y14.5M, 1982.
- CONTROLLING DIMENSION: INCH.
- TO BE DETERMINED AT PLANE -T-.
- DIMENSIONS A AND B DO NOT INCLUDE MOLD PROTRUSION. MOLD PROTRUSION SHALL NOT EXCEED 0.006 (0.150) PER SIDE.
- DIMENSIONS A AND B INCLUDE MOLD MISMATCH AND ARE DETERMINED AT THE PARTING LINE.
- DIMENSION F DOES NOT INCLUDE DAMBAR PROTRUSIONS. DAMBAR PROTRUSION SHALL NOT CAUSE THE F DIMENSION TO EXCEED 0.037 (0.94).
- FOR LEAD IDENTIFICATION PURPOSES, PIN POSITIONS 7 AND 20 ARE NOT USED.

DIM	INCHES		MILLIMETERS	
	MIN	MAX	MIN	MAX
A	0.670	0.680	17.01	17.28
B	0.295	0.305	7.50	7.74
C	0.128	0.148	3.26	3.75
D	0.015	0.020	0.38	0.51
E	0.103	0.116	2.62	2.95
F	0.026	0.032	0.66	0.481
G	0.050 BSC		1.270 BSC	
K	0.031	0.045	0.80	1.14
L	0.050 BSC		1.270 BSC	
N	0.035	0.045	0.89	1.14
P	0.328	0.340	8.35	8.63
R	0.260	0.275	6.61	6.99
S	0.030	0.040	0.77	1.01

T PACKAGE
300 MIL TSOP II
CASE 892A-02

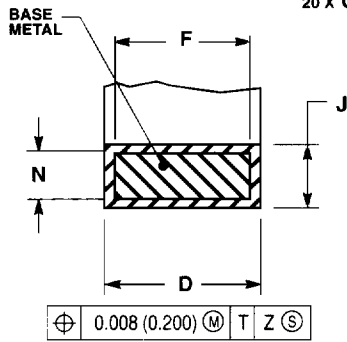
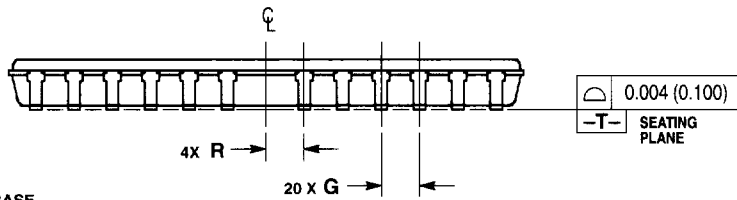
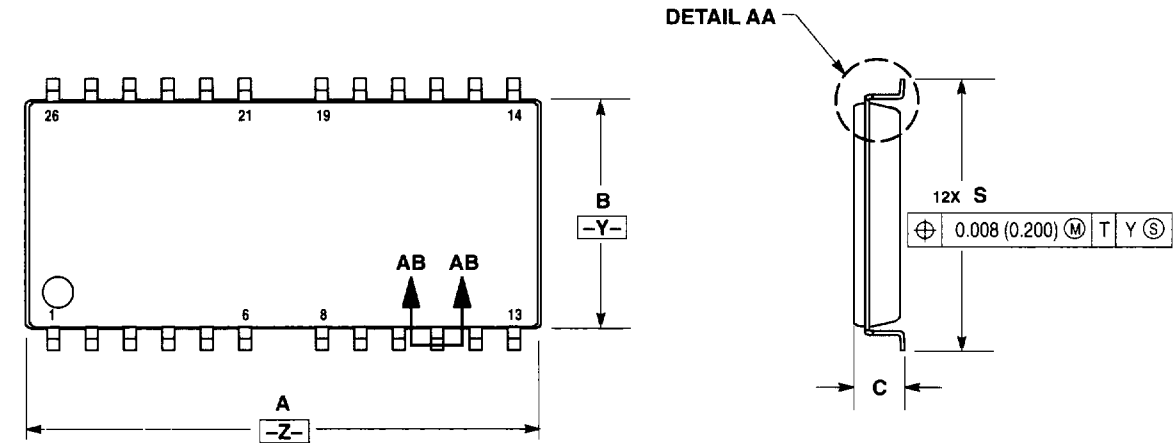

SECTION AB-AB
24 PLACES

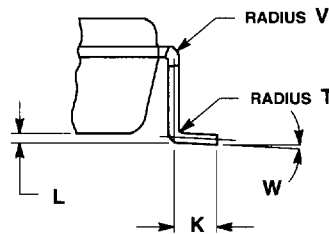

DETAIL AA
ROTATED 90° CLOCKWISE

NOTES:

1. DIMENSIONING AND TOLERANCING PER ANSI Y14.5M, 1982.
2. CONTROLLING DIMENSION: INCH.
3. DIMENSIONS A AND B DO NOT INCLUDE MOLD PROTRUSION. ALLOWABLE MOLD PROTRUSION IS 0.006 (0.150) PER SIDE.
4. DIMENSION D DOES NOT INCLUDE DAMBAR PROTRUSIONS. DAMBAR PROTRUSION SHALL NOT CAUSE THE LEAD WIDTH TO EXCEED 0.025 (0.635).
5. FOR LEAD IDENTIFICATION PURPOSES, PIN POSITIONS 7 AND 20 ARE NOT USED.

DIM	INCHES		MILLIMETERS	
	MIN	MAX	MIN	MAX
A	0.671	0.679	17.04	17.25
B	0.296	0.304	7.520	7.720
C	—	0.047	—	1.200
D	0.014	0.020	0.350	0.510
F	0.014	0.018	0.350	0.460
G	0.050 BSC		1.270 BSC	
J	0.004	0.008	0.100	0.200
K	0.016	0.024	0.400	0.600
L	0.002	0.008	0.050	0.200
N	0.0045	0.0055	0.100	0.140
R	0.050 BSC		1.270 BSC	
S	0.355	0.371	9.020	9.420
T	0.004 REF		0.100 REF	
V	0.004 REF		0.100 REF	
W	0°	10°	0°	10°

Motorola reserves the right to make changes without further notice to any products herein. Motorola makes no warranty, representation or guarantee regarding the suitability of its products for any particular purpose, nor does Motorola assume any liability arising out of the application or use of any product or circuit, and specifically disclaims any and all liability, including without limitation consequential or incidental damages. "Typical" parameters which may be provided in Motorola data sheets and/or specifications can and do vary in different applications and actual performance may vary over time. All operating parameters, including "Typicals" must be validated for each customer application by customer's technical experts. Motorola does not convey any license under its patent rights nor the rights of others. Motorola products are not designed, intended, or authorized for use as components in systems intended for surgical implant into the body, or other applications intended to support or sustain life, or for any other application in which the failure of the Motorola product could create a situation where personal injury or death may occur. Should Buyer purchase or use Motorola products for any such unintended or unauthorized application, Buyer shall indemnify and hold Motorola and its officers, employees, subsidiaries, affiliates, and distributors harmless against all claims, costs, damages, and expenses, and reasonable attorney fees arising out of, directly or indirectly, any claim of personal injury or death associated with such unintended or unauthorized use, even if such claim alleges that Motorola was negligent regarding the design or manufacture of the part. Motorola and (M) are registered trademarks of Motorola, Inc. Motorola, Inc. is an Equal Opportunity/Affirmative Action Employer.

How to reach us:

USA/EUROPE/Locations Not Listed: Motorola Literature Distribution;
P.O. Box 20912; Phoenix, Arizona 85036. 1-800-441-2447 or 602-303-5454

MFAX: RMFAX0@email.sps.mot.com -- TOUCHTONE 602-244-6609
INTERNET: <http://Design-NET.com>

JAPAN: Nippon Motorola Ltd.; Tatsumi-SPD-JLDC, 6F Seibu-Butsuryu-Center,
3-14-2 Tatsumi Koto-Ku, Tokyo 135, Japan. 03-81-3521-8315

ASIA/PACIFIC: Motorola Semiconductors H.K. Ltd.; 8B Tai Ping Industrial Park,
51 Ting Kok Road, Tai Po, N.T., Hong Kong. 852-26629298

