

DO NOT SCALE FROM THIS PRINT

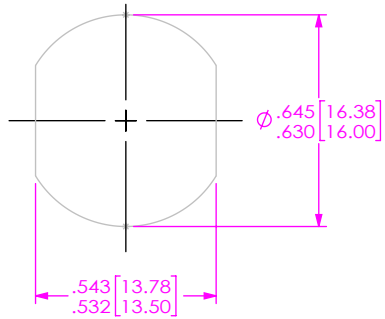

RECOMMENDED PANEL CUTOUT

DESIGNED & DIMENSIONED IN INCHES[MILLIMETERS]

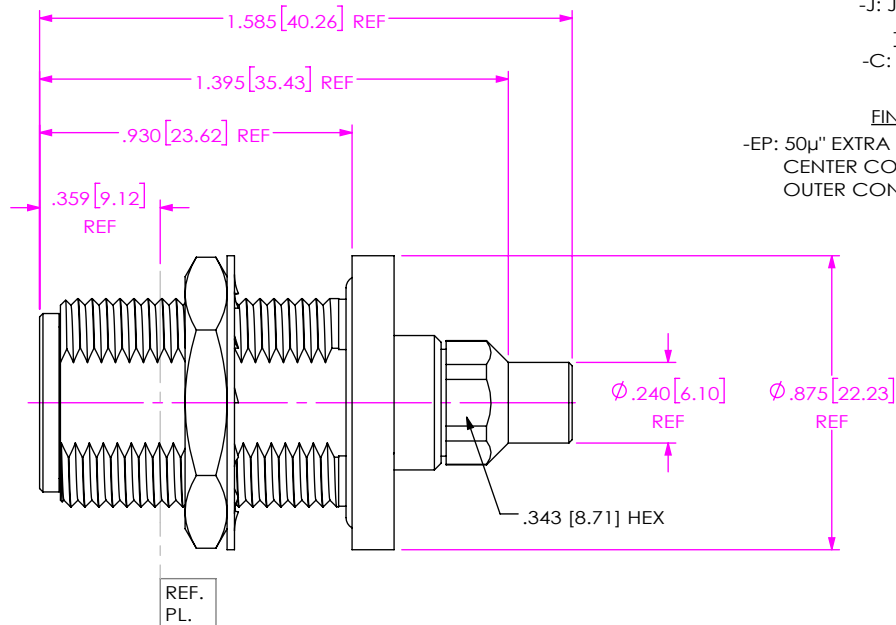

PRF06-J-C-EP-160A-BS

SERIES  
-06: NTPE

GENDER  
-J: JACK

TYPE  
-C: CABLE

FINISH  
-EP: 50µ" EXTRA HEAVY GOLD CENTER CONTACT, PASSIVATED OUTER CONTACT

TERMINATION  
-S: SOLDER CLAMP

ORIENTATION  
-B: BULKHEAD

CABLE TYPE  
-160: HARBOUR LL160

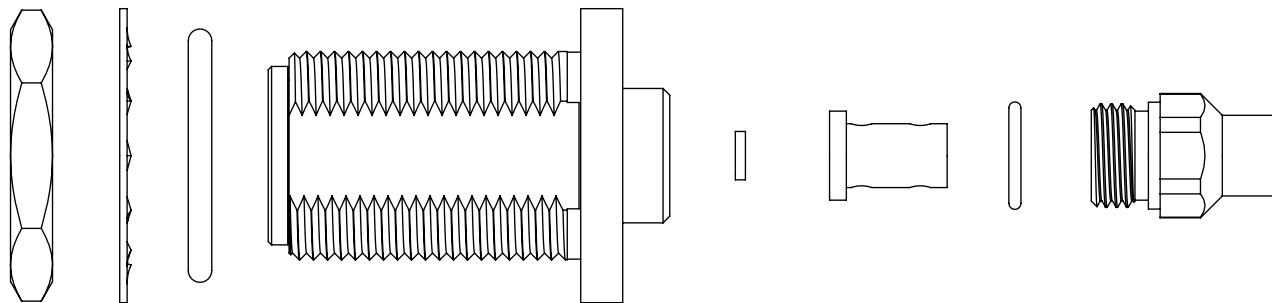
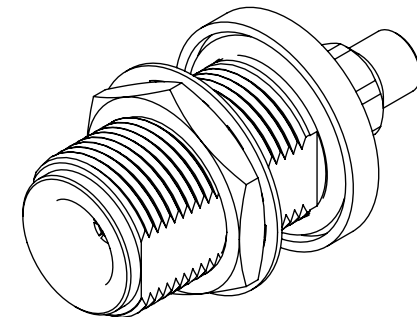

EXPLODED VIEW NOT TO SCALE (FOR CLARITY ONLY)

NOTES:

- MATERIAL:  
BODY, BUSHING, CLAMP NUT, LOCK WASHER, LOCK NUT: STAINLESS STEEL.  
CONTACT: BERYLLIUM COPPER.  
SOLDER FERRULE: BRASS ALLOY.  
BEADS: ULTEM.  
O-RINGS: SILICONE RUBBER.
- FINISH:  
BODY, BUSHING, CLAMP NUT, LOCK WASHER, JAM NUT: PASSIVATED.  
CONTACT, SOLDER FERRULE: 50µ" MIN. GOLD OVER 50µ" MIN. NICKEL PLATE.
- PCI P/N: 4050.

UNLESS OTHERWISE SPECIFIED, DIMENSIONS ARE IN INCHES. TOLERANCES ARE:

DECIMALS ANGLES  
.XX: ±.01[0.3] 1°  
.XXX: ±.005[0.13]  
.XXXX: ±.0005[0.013]

PROPRIETARY NOTE  
THIS DOCUMENT CONTAINS CONFIDENTIAL AND PROPRIETARY INFORMATION AND ALL DESIGN, MANUFACTURING, REPRODUCTION, USE, PATENT RIGHTS AND SALES RIGHTS ARE EXPRESSLY RESERVED BY SAMTEC, INC. THIS DOCUMENT SHALL NOT BE DISCLOSED, IN WHOLE OR PART, TO ANY UNAUTHORIZED PERSON OR ENTITY NOR REPRODUCED, TRANSFERRED OR INCORPORATED IN ANY OTHER PROJECT IN ANY MANNER WITHOUT THE EXPRESS WRITTEN CONSENT OF SAMTEC, INC.

DO NOT SCALE DRAWING SHEET SCALE: 1.75:1



520 PARK EAST BLVD, NEW ALBANY, IN 47150  
PHONE: 812-944-6733 FAX: 812-948-5047  
e-Mail info@SAMTEC.com code 55322

DESCRIPTION: N BULKHEAD JACK, SOLDER CLAMP FOR HARBOUR LL160 CABLE

DWG. NO. PRF06-J-C-EP-160A-BS

BY: EVE L 05/14/2021 SHEET 1 OF 3

# CABLE APPLICATION VIEWS

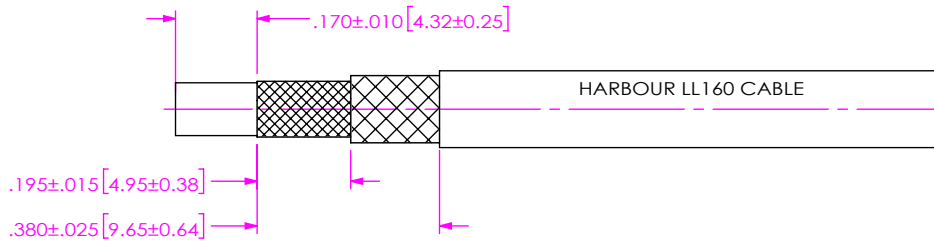

1A. TRIM CABLE TO EXPOSE DIELECTRIC AND BRAIDS AS SHOWN.

IN-PROCESS VIEW 1

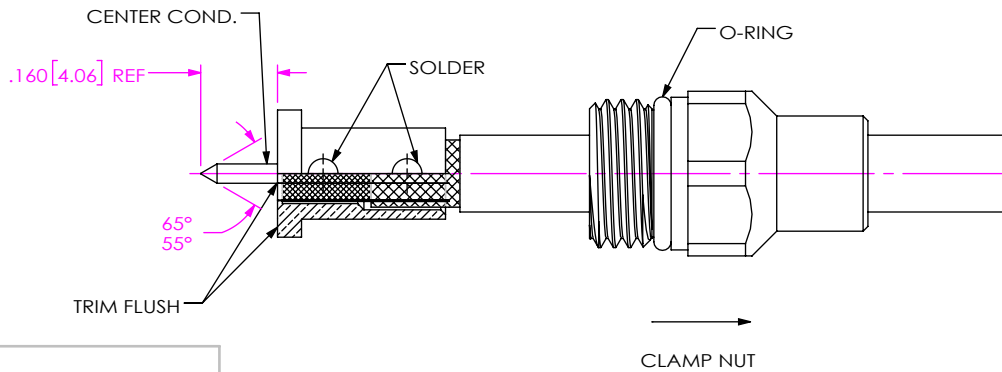

- 2A. INSTALL O-RING ONTO CLAMP NUT WHERE SHOWN AND SLIDE CLAMP NUT OVER CABLE IN ORIENTATION SHOWN.
- 2B. INSERT CABLE INTO SOLDER FERRULE UNTIL INNER BRAID SEATS THEN SOLDER TO FERRULE WHERE SHOWN.
- 2C. TRIM CABLE DIELECTRIC FLUSH WITH FACE OF SOLDER FERRULE.
- 2D. POINT CENTER CONDUCTOR AS SHOWN.

IN-PROCESS VIEW 2

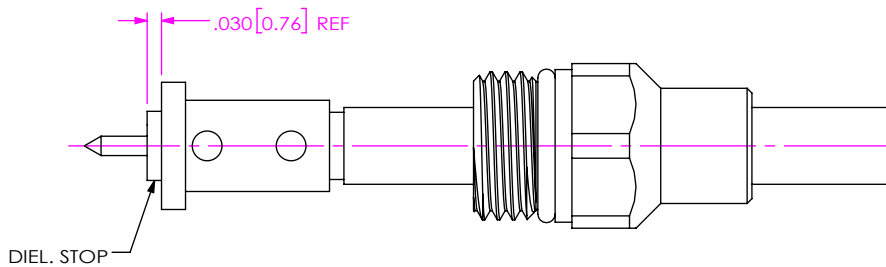

3A. SLIDE DIELECTRIC STOP ONTO CABLE CENTER CONDUCTOR FLUSH WITH SOLDER FERRULE FACE.

IN-PROCESS VIEW 3

**PROPRIETARY NOTE**  
 THIS DOCUMENT CONTAINS CONFIDENTIAL AND PROPRIETARY INFORMATION AND ALL DESIGN, MANUFACTURING, REPRODUCTION, USE, PATENT RIGHTS AND SALES RIGHTS ARE EXPRESSLY RESERVED BY SAMTEC, INC. THIS DOCUMENT SHALL NOT BE DISCLOSED, IN WHOLE OR PART, TO ANY UNAUTHORIZED PERSON OR ENTITY NOR REPRODUCED, TRANSFERRED OR INCORPORATED IN ANY OTHER PROJECT IN ANY MANNER WITHOUT THE EXPRESS WRITTEN CONSENT OF SAMTEC, INC.



520 PARK EAST BLVD, NEW ALBANY, IN 47150  
 PHONE: 812-944-6733 FAX: 812-948-5047  
 e-Mail: info@SAMTEC.com code 55322

DO NOT SCALE DRAWING

SHEET SCALE: 2.5:1

DESCRIPTION: N BULKHEAD JACK, SOLDER CLAMP FOR HARBOUR LL160 CABLE

DWG. NO. PRF06-J-C-EP-160A-BS

BY: EVE L 05/14/2021 SHEET 2 OF 3

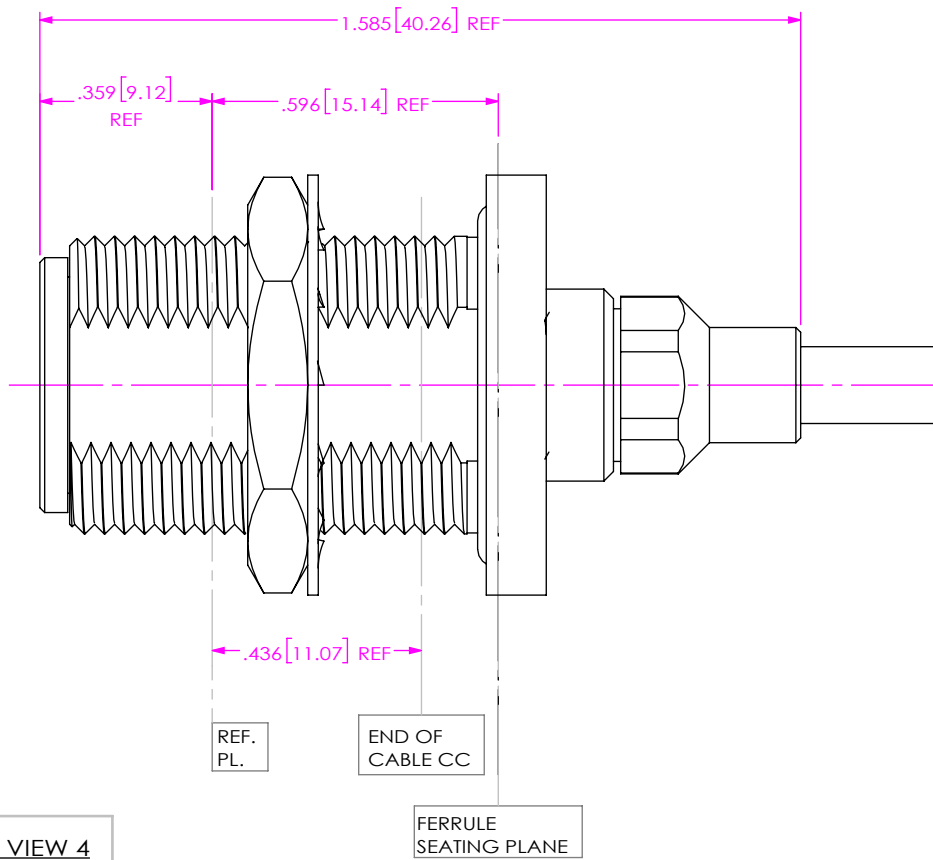

4A. INSERT CABLE/FERRULE SUB-ASSEMBLY INTO CONNECTOR UNTIL SEATED AND TIGHTEN CLAMP NUT TO 25-35 IN-LBS.

IN-PROCESS VIEW 4

**PROPRIETARY NOTE**

THIS DOCUMENT CONTAINS CONFIDENTIAL AND PROPRIETARY INFORMATION AND ALL DESIGN, MANUFACTURING, REPRODUCTION, USE, PATENT RIGHTS AND SALES RIGHTS ARE EXPRESSLY RESERVED BY SAMTEC, INC. THIS DOCUMENT SHALL NOT BE DISCLOSED, IN WHOLE OR PART, TO ANY UNAUTHORIZED PERSON OR ENTITY NOR REPRODUCED, TRANSFERRED OR INCORPORATED IN ANY OTHER PROJECT IN ANY MANNER WITHOUT THE EXPRESS WRITTEN CONSENT OF SAMTEC, INC.



520 PARK EAST BLVD, NEW ALBANY, IN 47150  
 PHONE: 812-944-6733 FAX: 812-948-5047  
 e-Mail: info@SAMTEC.com code 55322

DO NOT SCALE DRAWING

SHEET SCALE: 2.5:1

DESCRIPTION: N BULKHEAD JACK, SOLDER CLAMP FOR HARBOUR LL160 CABLE

DWG. NO. PRF06-J-C-EP-160A-BS

BY: EVE L 05/14/2021 SHEET 3 OF 3