

ENCODER/DECODER REMOTE-CONTROL 2-CHIP SET

Features

- ❑ Small Parts Count — No Crystals Required
- ❑ Easily Used in LED, Ultrasonic, RF, or Hardwire Transmission Schemes
- ❑ Very Low Reception Error
- ❑ Low Power Drain CMOS Transmitter for Portable and Battery Operation
- ❑ 31 Commands — 5-bit Output Bus With Data Valid
- ❑ 3 Analog (LP Filterable PWM) Outputs
- ❑ Muting (Analog Output Kill/Restore)
- ❑ Indexing Output — 2½ Hz Pulse Train
- ❑ Toggle Output (On/Off)
- ❑ Mask-Programmable Codes

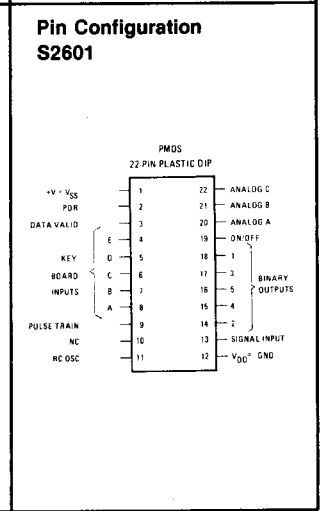
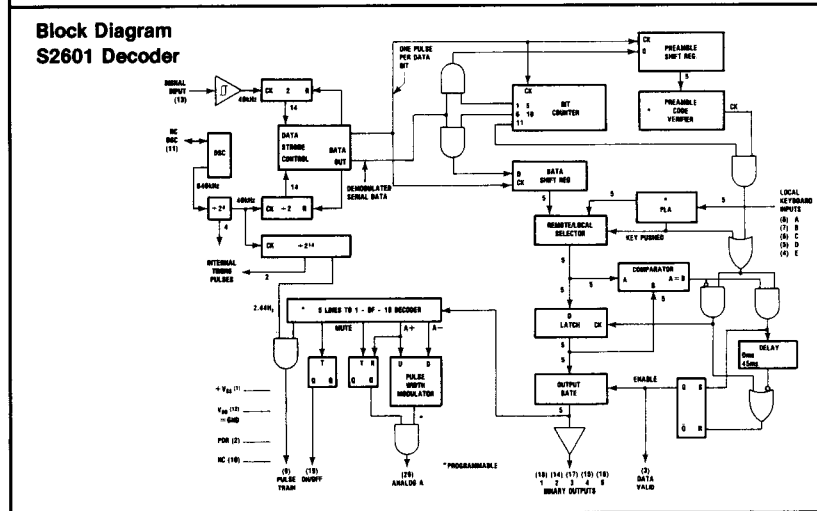
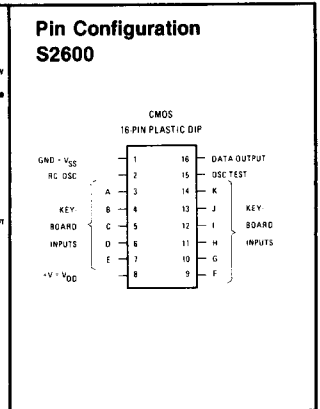
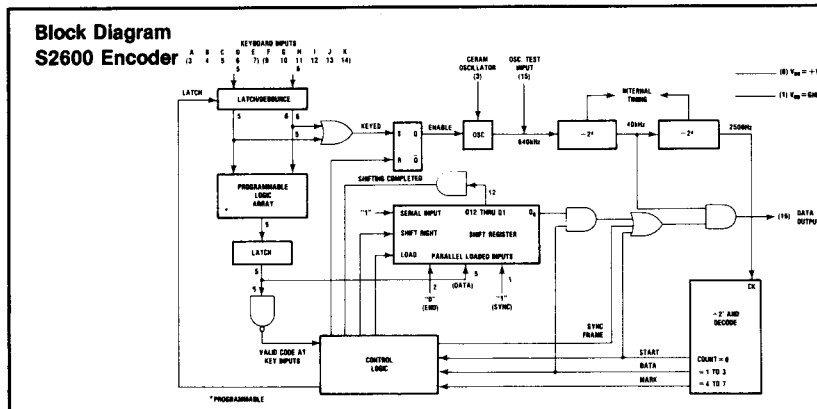

Functional Description

The S2600/S2601 is a set of two LSI circuits which allows a complete system to be implemented for remote control of televisions, toys, security systems, industrial controls, etc. The choice of transmission medium is up to the user and can be ultrasonic, infrared radio frequency, or hardwire such as twisted pair or telephone.

The use of a synchronizing marker technique has eliminated the need for highly accurate frequencies generated by crystals. The S2600 Encoder typically generates a 40kHz carrier which it amplitude-modulates with a base-band message of 12 bits, each bit preceded by a synchronizing marker pulse.

Bits 1 and 12 denote sync and end-of-message, respectively, bits 2 thru 6 constitute a fixed preamble which must be received correctly for the command bits to be received, and bits 7 through 11 contain the command data. The S2601 Decoder produces an output only after two complete, consecutive, identical, 12-bit transmissions. Marker pulses, preamble bits, and redundant transmissions, have given the S2600/S2601 system a very high immunity to noise, without a large number of discrete components.

S2600 Encoder

The S2600 is a CMOS device with an on-chip oscillator, 11 keyboard inputs, a keyboard encoder, a shift register, and some control logic. The oscillator requires only an external resistor and capacitor, and to conserve power, **runs only during transmission**. Keyboard inputs are active-low, and have internal pull-up resistors to V_{DD} . When one keyboard input from the group A through E is activated with one from the group F through K, the keyboard encoder generates a 5-bit code, as given in the table entitled "S2600/S2601 CODING," below. This code is loaded into a shift register in parallel with the sync, preamble, and end bits, to form the 12-bit message.

The transmitter output is a 40 kHz square wave of 50% duty factor which has been pulse-code-modulated by (i.e., ANDed with) a signal having a recurring pattern, a bit frame of 3.2 millisecond duration. This bit frame is comprised of three signals: the Start signal which is 0.4 milliseconds of logic "1"; followed by the Data signal which is 1.2 milliseconds of the lowest-order shift register bit; followed by the Mark signal which is 1.6 milliseconds of logic "0" (except in the first bit frame where Mark = 1 to facilitate receiver synchronization).

The shift register is clocked once per bit frame, so that its 12-bit message is transmitted once in a 38.4 milliseconds. The minimum number of transmissions that can occur is two, but if the keyboard inputs are active after the first 3.6 milliseconds of any 12-bit transmission, one more 12-bit transmission will result. Transmissions are always complete, never truncated, regardless of the keyboard inputs.

The Test input is used for functional testing of the device. A low level input will cause the oscillator frequency to be gated to the Data Output pin. This input has an internal pull-up resistor to V_{DD} .

S2601 Decoder

The S2601 is a PMOS LSI device with an on-chip oscillator, five keyboard inputs, a 40kHz signal input, and 11 outputs. The oscillator requires only an external R and C. The five keyboard inputs are active-low with internal pull-up resistors to V_{SS} ; activation of any two causes one of 10 possible 5-bit codes to be generated and fed to the outputs of the S2601, overriding any 40kHz signal input.

Two counters, the signal counter and the local counter, are clocked respectively by the signal input and a 40kHz signal from the local RC oscillator timing chain. A 40kHz input lasting 3.2 milliseconds (i.e., an initial bit frame) causes the signal counter to overrun and reset both itself and the local counter. At specific intervals thereafter, the local counter generates pulses used to interrogate the contents of the signal counter. Resynchronization of the counters occurs every bit frame so that the interrogation yields valid data bits even if the transmitter oscillator frequency has deviated up to $\pm 24\%$ with respect to the receiver oscillator frequency.

Decoded data bits from the next five bit frames following the initial synchronizing frame are compared with the fixed preamble code. The next five decoded bits, the command bits, are converted to a parallel format and are compared against the command bits saved from the prior transmission. If they match, and if the preamble bits are correct, the command bits are gated to the receiver outputs. However, a mismatch causes the receiver outputs to be immediately disabled, and the new command bits are saved for comparison against the command bits from the next 12-bit transmission. In the case where 2 identical, proper, 12-bit transmissions are immediately followed either by transmissions with erroneous preamble codes or by

nothing, the receiver outputs will be activated during the end-frame of the second transmission, and will be disabled 45 milliseconds thereafter. In the rest (disabled) state the five Binary Outputs are at a "1" logic level; when not in the rest state, one or more of the open-sourced output transistors will conduct to V_{DD} . The Data Valid output is low during the rest state, and high whenever data is present at the Binary Outputs.

The S2601 has five other outputs: Pulse Train, On/Off, Analog A, Analog B, and Analog C. The states of these outputs are controlled by the 10 particular Binary Output codes which the receiver Keyboard Inputs can cause to be generated. The Pulse Train output provides a 2.44kHz square wave (50% duty factor) whenever 11011 appears at the Binary Outputs, but otherwise it remains at a logic "0". This pulse train can be used for indexing, e.g., for stepping a TV channel selector.

The On/Off ("mains") output changes state each time 01111 appears at the Binary Outputs. In TV applications the On/Off output is most often used to kill and restore the main power supply.

Analog Outputs A, B and C are 10kHz pulse trains whose duty factors are independently controllable. With a simple low-pass filter each of these outputs can

provide 64 distinct DC levels suitable for control of volume, color saturation, brightness, motor speed, etc. Each Analog Output increases its duty factor in response to a particular Binary Output code and decreases its duty factor in response to another code—6 codes in all. The entire range of 0% to 100% duty factor can be traversed in 6.5 seconds or at a rate of the oscillator frequency divided by 2^{12} . All three Analog Outputs are set to 50% duty factor whenever 01011 appears at the Binary Outputs. Analog A is mutable; 01100 sets it to 0% duty factor. If 01100 then disappears and reappears, the original duty factor is restored. This of course implements the TV "sound killer" feature.

The S2601 has an on-chip power-on reset (POR) circuit which sets the Pulse Train and On/Off Outputs to "0", sets the Analog Outputs at 50% duty factor, and insures that Analog A is muted. No external components are required to implement POR, but a POR input has been provided for applications where externally controlled reset is desirable, e.g., where the power supply voltage rise time is extremely slow. The POR input has an internal resistor pull-up to V_{SS} ; pulling it low causes a reset.

Message Bit Format

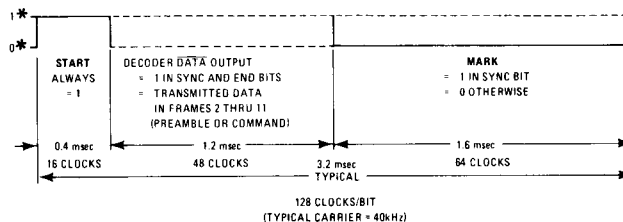

* "1" MEANS PRESENCE OF A 40kHz CARRIER (SQUARE WAVE); "0" MEANS ABSENCE OF A 40kHz CARRIER (SQUARE WAVE).

** IF MESSAGE BIT = "1" THEN DECODER DATA OUTPUT = ENCODER DATA INPUT = "0";
 IF MESSAGE BIT = "0" THEN DECODER DATA OUTPUT = ENCODER DATA INPUT = "1"

Message Format

