

## Rochester Electronics Manufactured Components

Rochester branded components are manufactured using either die/wafers purchased from the original suppliers or Rochester wafers recreated from the original IP. All recreations are done with the approval of the OCM.

Parts are tested using original factory test programs or Rochester developed test solutions to guarantee product meets or exceed the OCM data sheet.

## Quality Overview

- ISO-9001
- AS9120 certification
- Qualified Manufacturers List (QML) MIL-PRF-35835
  - Class Q Military
  - Class V Space Level
- Qualified Suppliers List of Distributors (QSLD)
  - Rochester is a critical supplier to DLA and meets all industry and DLA standards.

Rochester Electronics, LLC is committed to supplying products that satisfy customer expectations for quality and are equal to those originally supplied by industry manufacturers.

The original manufacturer's datasheet accompanying this document reflects the performance and specifications of the Rochester manufactured version of this device. Rochester Electronics guarantees the performance of its semiconductor products to the original OEM specifications. 'Typical' values are for reference purposes only. Certain minimum or maximum ratings may be based on product characterization, design, simulation, or sample testing.

## PRELIMINARY

February 1998

## CDMA/AMPS Downconverter with AGC Capability

### Features

- RF Frequency Range ..... 869MHz to 895MHz
- IF Operation ..... 10MHz to 100MHz
- LNA Gain......16dB
- LNA NF ..... 2.3dB
- Mixer Gain......16dB
- Mixer NF ..... 11dB
- Single Supply Battery Operation ..... 2.7V to 3.3V
- Power Enable/Disable Control
- PIN Diode Attenuator DC Control

### Applications

- IS95A CDMA/AMPS Dual Mode Handsets
- Wideband CDMA Handsets
- CDMA/TDMA Packet Protocol Radios
- Full Duplex Transceivers
- Portable Battery Powered Equipment



### Description

The HFA3665 is a monolithic bipolar downconverter for CDMA/AMPS cellular applications. Manufactured in the Harris UHF1X process, the device consists of a low noise cascode amplifier, a double balanced downconversion mixer and a pair of linearized and temperature compensated PIN diode biasing current sources for external RF AGC applications. In addition, the device offers two independent and selectable differential mixer IF output ports to be used with dual mode IF filters and requires low drive levels from the local oscillator. The HFA3665 is one of the four chips in the PRISM™ chip set and is housed in a small outline 28 lead SSOP package ideally suited for cellular handset applications.

### Ordering Information

PART NUMBER	TEMP. RANGE (°C)	PACKAGE	PKG. NO.
HFA3665IA	-40 to 85	28 Ld SSOP	M28.15
HFA3665IA96	-40 to 85	Tape and Reel	

### Pinout

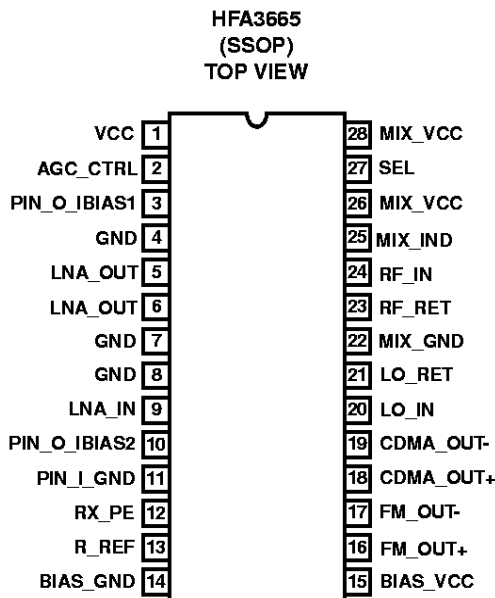

### Block Diagram

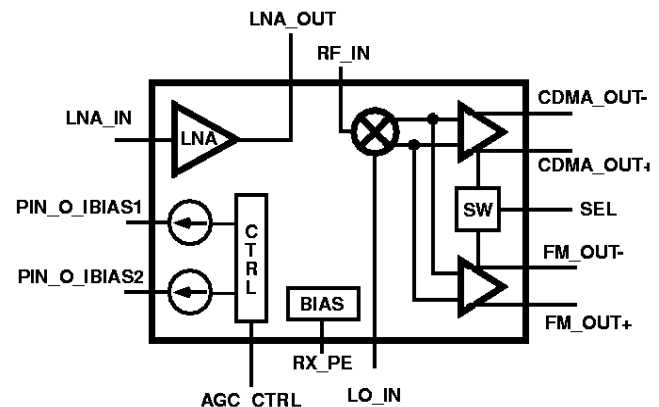

PRISM™ and the PRISM™ logo are trademarks of Harris Corporation.

## HFA3665

### Pin Descriptions

Pin Number	NAME	DESCRIPTION
1	VCC	LNA and PIN diode bias control Power Supply .Use high quality RF decoupling capacitors at the pin.
2	AGC_CTRL	AGC control current input pin. Requires a 9.53K 1% resistor for scale factor and temperature compensation of the current sources.
3	PIN_O_IBIAS1	Current output for a PIN diode bias control. Use a 2200pF filter capacitor to ground.
4	GND	LNA bias ground return.
5,6	LNA_OUT	LNA open collector output. This pins are internally bonded to the same device output.
7,8	GND	LNA RF ground return. Degeneration (inductance) can be added to this pin.
9	LNA_IN	LNA input.
10	PIN_O_IBIAS2	Second current output for PIN diode bias control. Use a 2200pF filter capacitor to ground.
11	PIN_I_GND	PIN diode bias control ground return.
12	RX_PE	Power enable control input. HIGH for normal operation. LOW for power down.
13	R_REF	Bias setting resistor. 523Ω 1% for optimum performance and parameter distribution.
14	BIAS_GND	Reference circuit ground return.
15	BIAS_VCC	Reference circuit Power Supply. Use high quality RF decoupling capacitors right at the pin.
16	FM_OUT+	Positive IF FM output. Open collector PNP. Requires a DC return to ground.
17	FM_OUT-	Negative IF FM output. Open collector PNP. Requires a DC return to ground.
18	CDMA_OUT+	Positive IF CDMA output. Open collector PNP. Requires a DC return to ground.
19	CDMA_OUT-	Negative IF CDMA output. Open collector PNP. Requires a DC return to ground.
20	LO_IN	Mixer Local Oscillator input. Requires AC coupling and directly matches to 50Ω.
21	LO_RET	Mixer Local Oscillator complementary input. Requires a bypass capacitor to ground as a return reference.
22	MIX_GND	Mixer ground return.
23	RF_RET	Mixer RF port complementary input. Requires a bypass capacitor to ground as a return reference.
24	RF_IN	Mixer RF input. Requires AC coupling and a match network to 50Ω.
25	MIX_IND	Mixer common mode bias inductor. Use a RF choke to ground with high impedance at 900MHz. Low loss inductors with parallel resonance close to 900MHz are ideal .
26,28	MIX_VCC	Mixer Power Supply Pins.Use high quality RF decoupling capacitors at each one of the pins.
27	SEL	Selects the CDMA or the FM output IF amplifier. HIGH selects the CDMA amplifier. LOW the FM amplifier output.

# HFA3665

## Absolute Maximum Ratings

Supply Voltage ..... -0.3 to 3.6V  
 Voltage on Any Other Pin except 5 and 6 (6.0V) . -0.3 to V<sub>CC</sub> +0.3V

## Operating Conditions

Supply Voltage Range ..... 2.7V to 3.3V  
 Operating Temperature Range ..... -40°C ≤ T<sub>A</sub> ≤ 85°C

## Thermal Information

Thermal Resistance (Typical, Note 1) θ<sub>JA</sub> (°C/W)  
 SSOP Package ..... 88  
 Maximum Junction Temperature (Plastic Package) ..... 150°C  
 Maximum Temperature Range ..... -40°C ≤ T<sub>A</sub> ≤ 85°C  
 Maximum Storage Temperature Range ..... -65°C ≤ T<sub>A</sub> ≤ 150°C  
 Maximum Lead Temperature (Soldering 10s) ..... 300°C  
 (Lead Tips Only)

*CAUTION: Stresses above those listed in "Absolute Maximum Ratings" may cause permanent damage to the device. This is a stress only rating and operation of the device at these or any other conditions above those indicated in the operational sections of this specification is not implied.*

**NOTE:**

1. θ<sub>JA</sub> is measured with the component mounted on an evaluation PC board in free air.

## Electrical Specifications

PARAMETER	TEST CONDITION	(Note 2) TEST LEVEL	TEMP (°C)	MIN	TYP	MAX	UNITS
<b>LNA SPECIFICATIONS AT 885MHz, VCC = 3.0V, VLNA = 3.0V unless otherwise specified (Test schematics as in page 5)</b>							
RF Frequency Range	Output Match net.	B	25	869	-	895	MHz
Power Gain	-30dBm input	A	25	14	16.0	17.5	dB
IP3I, Input referenced 3rd Order Intercept	VLNA = 3.0V	A	25		+2		dBm
	VLNA = 3.6V	A	25		+6		dBm
	VLNA = 5.0V	A	25		+7.5	-	dBm
IP1dB, Input referenced compression point	VLNA = 3.6V	A	25		-7	-	dBm
Noise Figure		B	25	-	2.3	-	dB
Input VSWR		A	25	-	2.2:1	2.5:1	-
Output VSWR	Output network as in the Apps. diagram	A	25	-	1.6:1	2.0:1	-
<b>MIXER SPECIFICATIONS AT -3dBm LO @ 970MHz AND IF of 85MHz</b>							
RF Frequency Range (Typical)		B	25	869	-	895	MHz
IF Frequency Range		B	25	10	85	100	MHz
LO Frequency Range (Typical)		B	25	954	-	980	MHz
Power Conversion Gain	Note 3	A	25	15.1	16.7	18.3	dB
Voltage Conversion Gain	Differential IF output load = 2.95K.	B	25	-	34.4	-	dB
Gain Flatness across the RF freq. range		B	25	-	-	0.6	dB
Noise Figure, SSB	Note 3	B	25	-	10.6	11.4	dB
IP3I, Input referenced 3rd Order Intercept		A	25	0	2.6	-	dBm
IP1dB, Input referenced compression point		A	25	-	-10	-	dBm
LO Drive Level		A	25	-6	-3	0	dBm
LO to IF Isolation		A	25	-	30	-	
LO to RF Isolation		A	25	20	32	-	dB

## HFA3665

### Electrical Specifications (Continued)

PARAMETER	TEST CONDITION	(Note 2) TEST LEVEL	TEMP (°C)	MIN	TYP	MAX	UNITS
RF VSWR	Input network as in the Apps diagram	A	25	-	1.6:1	2:1	-
LO VSWR		A	25	-	2.0:1	-	-
IF Output Parallel Resistance CDMA or FM port (85MHz) Single End to GND.		B	25	-	12.4	-	KΩ
IF Output Parallel Capacitance CDMA or FM port (85MHz) Single End to GND.		B	25	-	1.7	-	pF

#### PIN DIODE BIAS CURRENT SOURCE SPECIFICATIONS ( EACH OUTPUT Terminated into 0.7V)

Typical PIN diode AGC Range	Application schemat.	B	Full	33	38	-	dB
AGC_CTRL Voltage control Range	Rseries = 9.53K	A	25	0.5	-	2.5	V
PIN_O_IBIAS Max. Source Current.	AGC_CTRL = 2.0V	A	25	-	5.2	-	mA
PIN_O_IBIAS Current	AGC_CTRL = 1.8	A	25	-	3.0	-	mA
	AGC_CTRL = 1.4V	A	25	-	0.47	-	mA
	AGC_CTRL = 1.0V	A	25	-	0.04	-	mA
PIN_O_BIAS Leakage current	AGC_CTRL = 0.5V	A	25	-	0.0	-	mA
PIN_O_IBIAS Current Vs Temperature	AGC_CTRL = 1.8V	B	25	-	200	-	uA/°C
PIN_O_IBIAS Current Vs Supply Voltage	AGC_CTRL = 1.8V	B	25	-	330	-	uA/V

#### POWER SUPPLY AND LOGIC SPECIFICATIONS

Supply Voltage		B	25	2.7	-	3.3	V
LNA Power supply (VLNA)		C	25	2.7	-	5.5	V
SEL And RX_PE ,V <sub>IL</sub>		A	25	-	-	0.8	V
SEL And RX_PE ,V <sub>IH</sub>		A	25	2.0	-	-	V
SEL AND RX_PE, Input Bias Currents @ VCC = 3.0V	V <sub>IH</sub> = 3.0V	A	25	-200	-	+200	μA
	V <sub>IL</sub> = 0.0V	A	25	-200	-	+200	uA
LNA/Mixer Supply Current	AGC_CTRL = 0.5V	A	25	-	45	-	mA
Total PIN Diode Bias Circuit Supply Current	AGC_CTRL = 1.8V	B	25	-	11	-	mA
Power Down Supply Current	RX_PE = Low	A	25	-	10	100	μA
Power Down Speed		B	25	-	-	10	μs

#### NOTES:

2. A = Production Tested, B = Based on Characterization, C = By Design
3. Output differential to single end match network to 50Ω for both CDMA and FM IF ports (Production Test Diagram in page 5).

Production Test Diagram

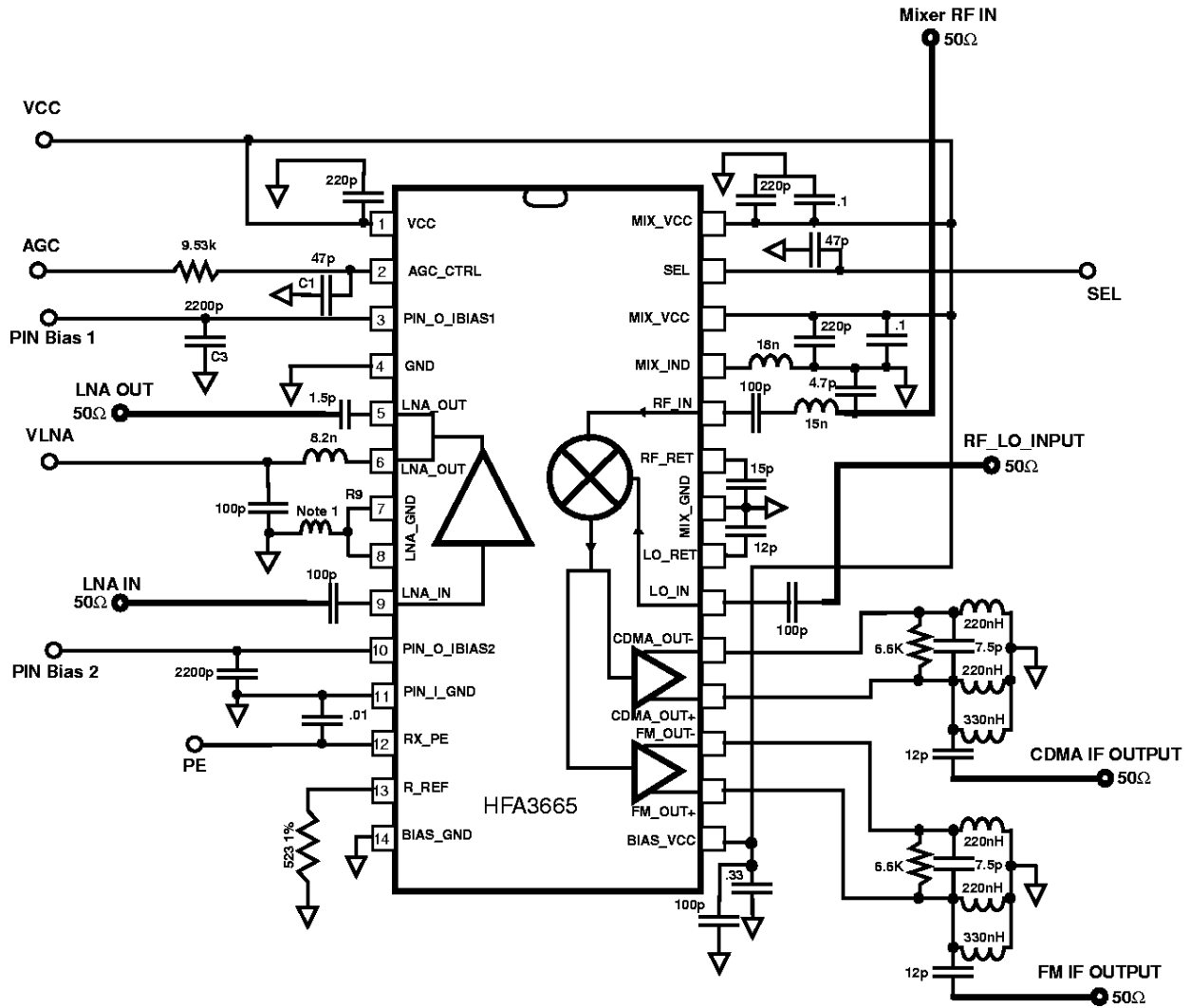

**Note 1. PC trace degeneration inductor.** 93mil by 8mil trace terminating in a 10mil via.  
Via is tied to a buried solid ground plane 12mils deep.  
Material is FR4 Er=4.7.

Typical RF Front End AGC Application

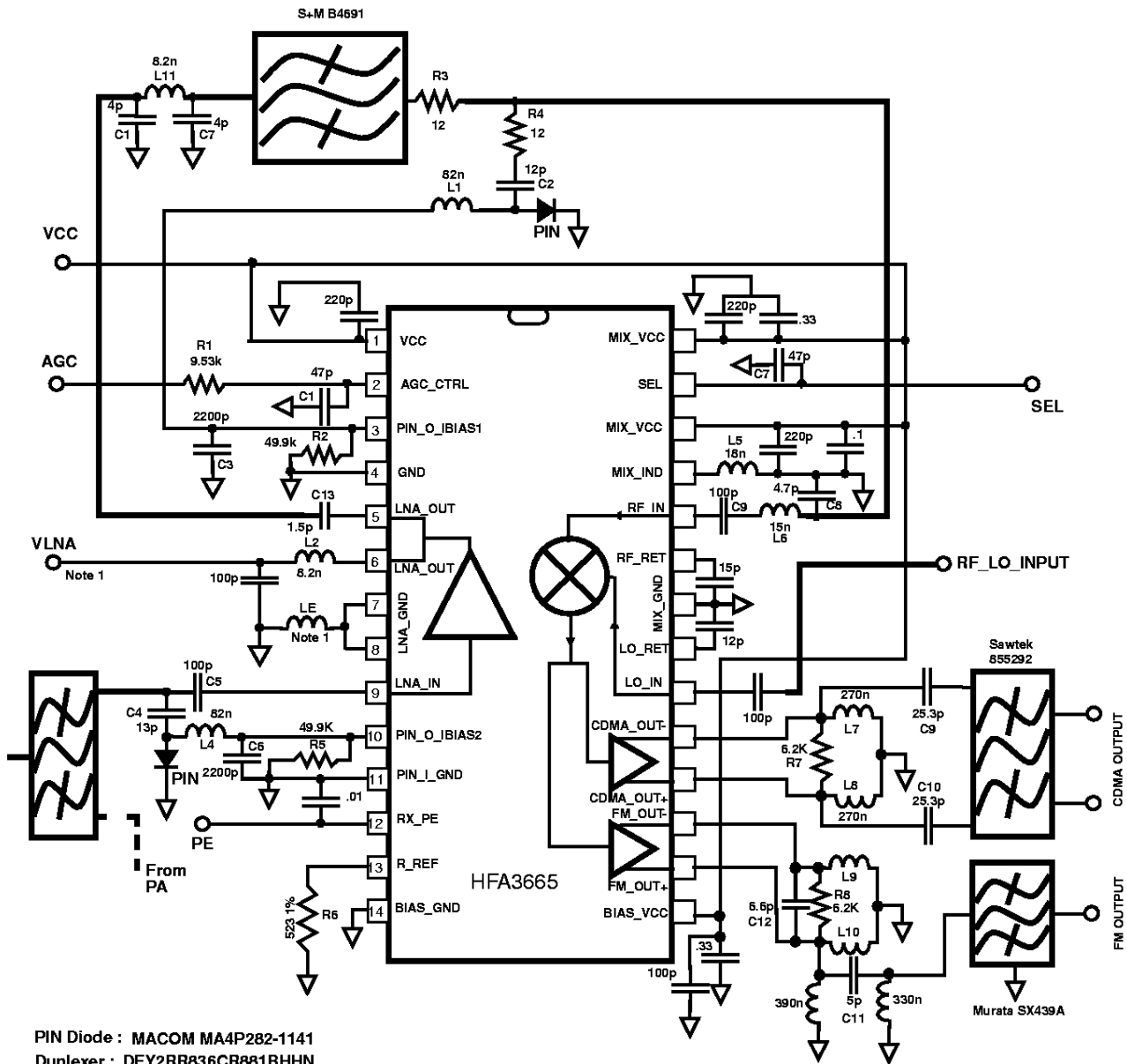

PIN Diode : MACOM MA4P282-1141

Duplexer : DFY2RR836CR881BHNN

Note 1: LNA degeneration inductance built with a PC trace to ground in combination with VLNA power supply to improve IIP3. A transmission line inductance of 1.2nH @ 882MHz to a solid ground plane is typical. (See test diagram)

## DESIGN INFORMATION

### **External AGC Application Components**

**Description:** Please refer to page 6

**NOTE:** In order to avoid input insertion losses and maintain the Noise Figure of this application optimized, the VSWR of the LNA input attenuator scheme is directly impacted by the input shunt PIN diode impedance when AGC is in action. This mismatch is absorbed by the duplexer/filter and there is no significant impact in its duplex characteristics to both antenna and transmitter ports.

**R3 & R4** limit the output attenuation range and output VSWR.

**R1** sets the scale factor, temperature coefficient and range of the gain control voltage.

**R2** sets the turn-on point for the output PIN diode attenuator and **R5** sets the turn-on point for the input PIN diode attenuator by shunting to ground some of the PIN diode bias current. By making R5 a smaller value than R2, the output attenuator turns on first, to optimize NF. Making  $R5 = R2$  will turn both PIN diodes simultaneously to optimize the IIP3 during the initial AGC action. The R2/R5 combination can be tailored to specific AGC characteristics.

**R6** generates the reference current which is used to set the operating point of all the major RF & IF transistors. A proportional to temperature (PTAT) voltage of about  $37\text{mV}@25^{\circ}\text{C}$  is applied to this resistor. PTAT biasing keeps the gain temperature independent. A 10% variation from  $523\Omega$  is allowed. Lower values increase the total LNA and Mixer bias currents.

**C1** filters noise from the gain control source to reduce unwanted AM modulation.

**C2 & C4** provide DC isolation for PIN diode biasing. Their values are chosen to provide series resonance cancelling of the diode package & PC board inductances.

**C3 & C6** decouple the PIN diode bias pins. Failure to decouple these pins may cause LNA oscillations.

**LE** adds degeneration to the LNA input for higher input intercept points. This combination of degeneration and a higher LNA VCC (VLNA) improves considerably the input intercept point with a slight decrease in gain. LE shall have very high Q and can be build with a small PC trace.

**L1 & L4** permit DC biasing of the PIN diodes and RF isolation. Several types of 82nH inductors have SRF near 900MHz thus maximizing the RF isolation.

**L2 & C13** are part of the output matching network and provides the DC bias path for the open collector output.

**R7 & R8** define the Real part of the CDMA and FM output ports impedances. Unloaded "Q" of the coils used for proper biasing of these ports have to be taken into account when defining these values. The total load presented to these

ports also define the achievable gain of the mixers. Because there is no internal feedback between the complementary ports of the differential channel, the loads and ports can be split into independent ports referenced to ground.

**L7,L8 & L9, L10** have two functions: They provide a DC path to ground required for proper operation of the CDMA and FM differential outputs and can also be part of the match network between these ports and IF filters. **C9,C10** and **C12** are part of a match network to the suggested filters. **L9,L10** and **C12** are part of a current summer network for a differential to single end conversion. **L12, L13** and **C11** form a high "Q" match network between the converter and the suggested filter for the SAW IP3 distortion optimization.

All other unlabeled components on the schematics are bypass/decoupling capacitors. Values are chosen based on their SRF.