

SMC3100-9178	SMC Plug Crimp Right Angle	50Ω
--------------	----------------------------	-----

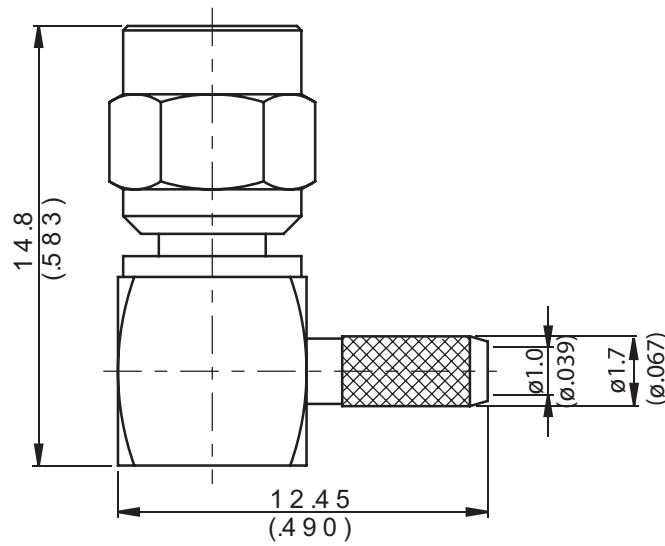

Parts	Material	Plating (Micro-inch)
Ferrule	Brass	Gold 5 Over Nickel 50 Over Copper 50
Cover	Brass	Gold 5 Over Nickel 50 Over Copper 50
Contact Pin	Beryllium Copper	Gold 20 Over Nickel 50 Over Copper 50
Insulator	Teflon	
Body	Brass	Gold 5 Over Nickel 50 Over Copper 50
Barrel	Brass	Gold 5 Over Nickel 50 Over Copper 50
Coupling Nut	Brass	Gold 5 Over Nickel 50 Over Copper 50

Weight: 2.89 g
 Suitable Cables: RG178, RG196, RG17-FEP

This part number complies with RoHS.
Notice: JYEBAO reserves the right to make modifications deemed appropriate.

CABLE ASSEMBLY INSTRUCTION

SMC3100-9178

JYE BAO CO., LTD.

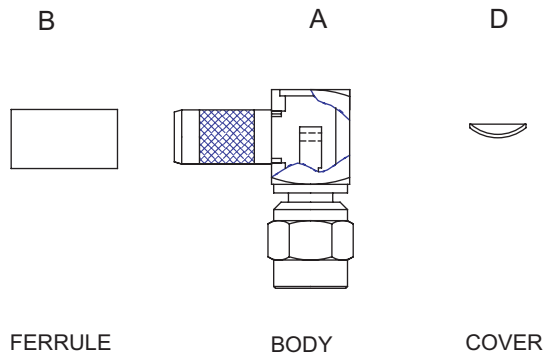

* TOOLS AND FIXTURES ARE REFERENCE ON
PAGE 306 OF JYEBAO'S 2005 CATALOG.

DIAGRAM	ASSEMBLY INSTRUCTION
	<p>Step 1: STRIP AS SHOWN.</p>
	<p>Step 2: SLIDE FERRULE " B " OVER CABLE . Step 3: WRAP THE BRAIDING UPWARDS. Step 4: SLIDE CENTER CONDUCTOR ON THE CONTACT PIN OF CONNECTOR " A " AND SOLDER IN " Y "</p>
	<p>Step 5: SLIDE FERRULE " B " TOWARDS THE CONNECTOR " A " AND CRIMP .</p>
	<p>Step 6: PRESS ON THE TOP OF " D " WITH JIGS .</p>

This part number complies with RoHS.

Notice: JYEBAO reserves the right to make modifications deemed appropriate.