

# ATTENUATORS

## MULTI-CHANNEL MEMS ATTENUATOR MODULE

DiCon's Multi-Channel MEMS Attenuator Module consists of an array of 8 or less MEMS Attenuator components which are used for multi-channel attenuation. DiCon's MEMS Attenuator is based on a micro-electro-mechanical system (MEMS) chip. Multi-Channel MEMS Attenuator Modules create a significant reduction in the amount of board space which needs to be dedicated to attenuation.



## FEATURES

- Low polarization dependent loss over the entire wavelength range
- Ultra-low current consumption
- Smallest multi-channel attenuator package in the telecom industry
- Qualified to GR-1221

## APPLICATIONS

Multi-Channel MEMS Attenuator Modules are used to attenuate power levels for multiple wavelength channels or bands. Primary applications include dynamic gain equalizers, DWDM and MUX/DMUX module power level control.



# ATTENUATORS

## OPTICAL SPECIFICATIONS<sup>1,2</sup>

Wavelength range	C Band	1528 - 1563 nm	
	L Band	1570 - 1610 nm	
Insertion loss		0.8 dB max.	
Temperature dependence <sup>3,6</sup>		0.3 dB max.	
Polarization dependent loss	0 to 15 dB	0.15 dB max.	
	15 to 20 dB	0.2 dB max.	
Flatness	Broad band Application <sup>4</sup>	0 to 15 dB	0.4 dB max.
		0 to 20 dB	0.7 dB max.
	Narrow band Application <sup>5</sup>	0 to 20 dB	0.2 dB max.
Polarization mode dispersion		0.1 ps max.	
Back-reflection		-50 dB max.	
Optical power		300 mW max.	
Response speed		2 ms max.	
Repeatability		0.1 dB max.	
Wear-out		1 x 10 <sup>8</sup> cycles min.	
Fiber type		9/125 Corning SMF-28	
Fiber jacket		250 micron, 200 kpsi bare fiber	
Operating temperature		-5 <sup>o</sup> C to +75 <sup>o</sup> C	
Storage temperature		-40 <sup>o</sup> C to +85 <sup>o</sup> C	

- All specifications referenced without connectors in C or L band.
- Relative to 23<sup>o</sup>C.
- At minimum loss position.
- Maximum variation over whole C or L band, depending on part number.
- Maximum change of each 400 GHz segment within C or L band, depending on part number.
- Over operating temperature.

## ELECTRICAL SPECIFICATIONS

Latching type	Non-latching
DC drive voltage	0 - 5 VDC
Voltage damage threshold	10 VDC max.
Resistance	100 Kohms min./Attenuator
Capacitance	2 pF typ./Attenuator
Power consumption	20 uWatt max./Attenuator

## HOUSING DIMENSIONS

4 channel	7 pins	39.0 x 26.0 x 9.6 mm
8 channel	12 pins	39.0 x 48.0 x 9.6 mm

## ORDERING INFORMATION

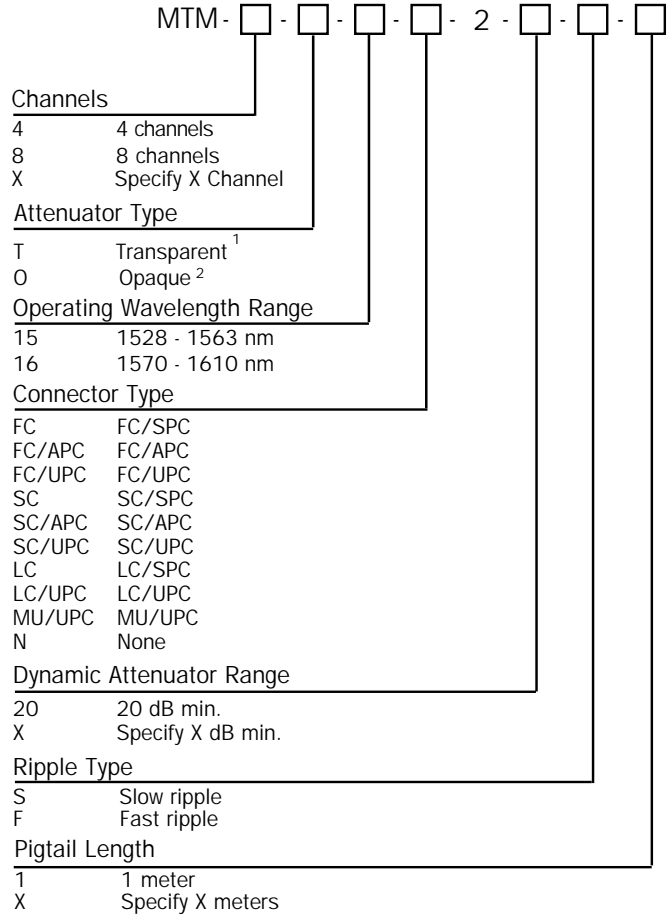

- Minimum insertion loss at 0 V.
- Power off and optical off minimum insertion loss @ 6.5 V or specify @ X V.

## 8 CHANNEL DRAWING<sup>1</sup>

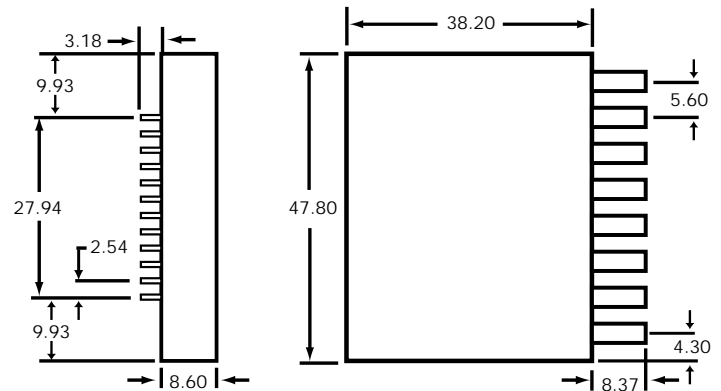

Units: mm

- Detail drawing of 10 channel modules available upon request.