

# S8740280GT

GaAs Push Pull Hybrid  
40MHz to 870MHz

The S8740280GT is a Hybrid Push Pull amplifier module. The part employs GaAs die and is operated from 40MHz to 870MHz. It provides excellent linearity and superior return loss performance with low noise and optimal reliability.

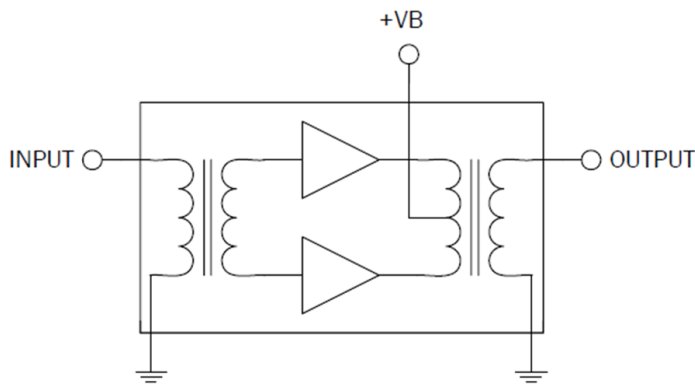

Package: SOT-115J

## Features

- Excellent Linearity
- Superior Return Loss Performance
- Extremely Low Distortion
- Optimal Reliability
- Low Noise
- Unconditionally Stable Under All Terminations
- 28.0dB Min. Gain at 870MHz
- 260mA Max. at 24V<sub>DC</sub>

## Applications

- 40MHz to 870MHz CATV Amplifier Systems

## Ordering Information

S8740280GT      Box with 50 Pieces

## Absolute Maximum Ratings

Parameter	Rating	Unit
RF Input Voltage (single tone)	75	dBmV
DC Supply Over-Voltage (5 minutes)	30	V
Storage Temperature	-40 to +100	°C
Operating Mounting Base Temperature	-30 to +100	°C



**Caution!** ESD sensitive device.



RoHS (Restriction of Hazardous Substances): Compliant per EU Directive 2011/65/EU.

Exceeding any one or a combination of the Absolute Maximum Rating conditions may cause permanent damage to the device. Extended application of Absolute Maximum Rating conditions to the device may reduce device reliability. Specified typical performance or functional operation of the device under Absolute Maximum Rating conditions is not implied.

## Nominal Operating Parameters

Parameter	Specification			Unit	Condition
	Min	Typ	Max		
<b>General Performance</b>					<b>V+ = 24V; T<sub>MB</sub> = 30°C; Z<sub>S</sub> = Z<sub>L</sub> = 75Ω</b>
Power Gain	26.7	27.0	27.3	dB	f = 45MHz
	28.0	28.5	29.0	dB	f = 870MHz
Slope <sup>[1]</sup>	1.0	1.5	2.0	dB	f = 45MHz to 870MHz
Flatness of Frequency Response			±0.5	dB	f = 45MHz to 870MHz (peak to valley)
Input Return Loss	20.0			dB	f = 40MHz to 550MHz
	19.0			dB	f = 550MHz to 640MHz
	18.0			dB	f = 640MHz to 870MHz
Output Return Loss	21.0			dB	f = 40MHz to 80MHz
	19.0			dB	f = 80MHz to 160MHz
	17.0			dB	f = 160MHz to 870MHz
Noise Figure			5.0	dB	f = 50MHz to 870MHz
Total Current Consumption (DC)		250.0	260.0	mA	
<b>Distortion Data 40MHz to 870MHz</b>					<b>V+ = 24V; T<sub>MB</sub> = 30°C; Z<sub>S</sub> = Z<sub>L</sub> = 75Ω</b>
CTB			-65	dBc	132 ch. flat; V <sub>O</sub> = 40dBmV <sup>[2]</sup>
XMOD			-58	dBc	
CSO			-63	dBc	132 ch. flat; V <sub>O</sub> = 40dBmV; sum beats <sup>[2]</sup>

1. The slope is defined as the difference between the gain at the start frequency and the gain at the stop frequency.

2. 132 channels, NTSC frequency raster: 55.25MHz to 865.25MHz, +40dBmV flat output level.

Composite Second Order (CSO) - The CSO parameter (both sum and difference products) is defined by the NCTA.

Composite Triple Beat (CTB) - The CTB parameter is defined by the NCTA.

Cross Modulation (XMOD) - Cross modulation (XMOD) is measured at baseband (selective voltmeter method), referenced to 100% modulation of the carrier being tested.

## Package Drawing (Dimensions in millimeters)

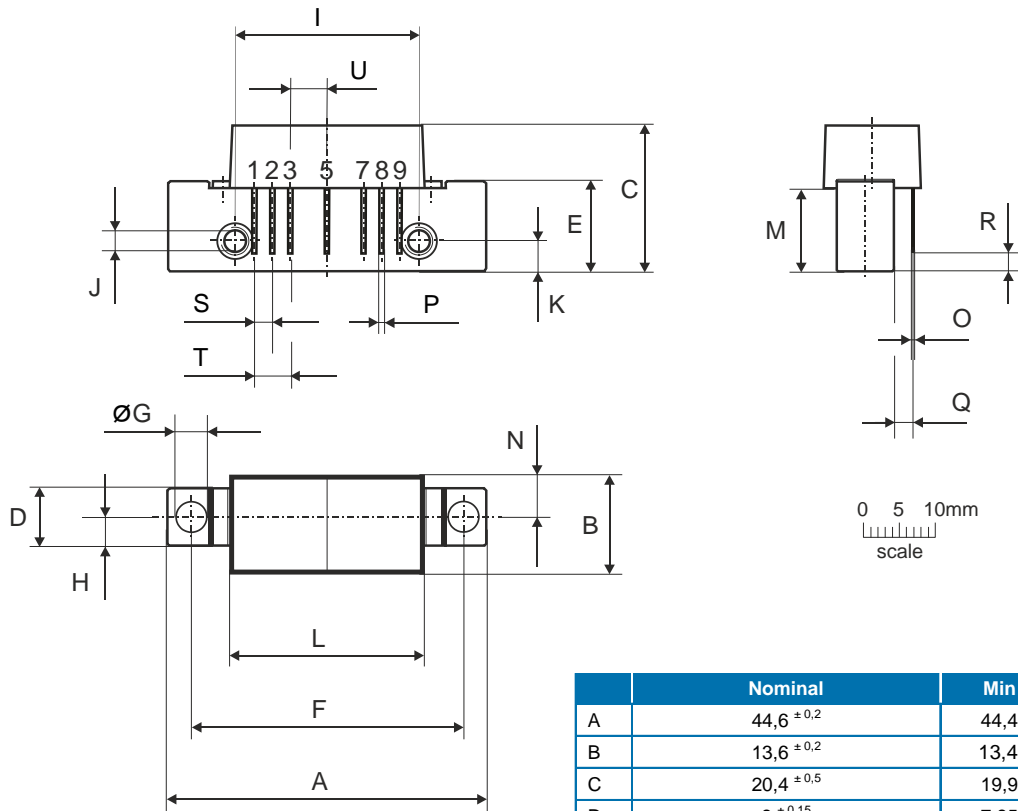

### Notes:

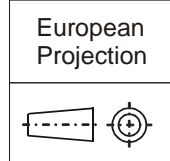

### Pinning:

Pin	Name
1	Input
2-3	GND
4	
5	+VB
6	
7-8	GND
9	Output

	Nominal	Min	Max
A	44,6 ±0,2	44,4	44,8
B	13,6 ±0,2	13,4	13,8
C	20,4 ±0,5	19,9	20,9
D	8 ±0,15	7,85	8,15
E	12,6 ±0,15	12,45	12,75
F	38,1 ±0,2	37,9	38,3
G	4 <sup>+0,2/-0,05</sup>	3,95	4,2
H	4 ±0,2	3,8	4,2
I	25,4 ±0,2	25,2	25,6
J	UNC 6-32	-	-
K	4,2 ±0,2	4,0	4,4
L	27,2 ±0,2	27,0	27,4
M	11,6 ±0,5	11,1	12,1
N	5,8 ±0,4	5,4	6,2
O	0,25 ±0,02	0,23	0,27
P	0,45 ±0,03	0,42	0,48
Q	2,54 ±0,3	2,24	2,84
R	2,54 ±0,5	2,04	3,04
S	2,54 ±0,25	2,29	2,79
T	5,08 ±0,25	4,83	5,33
U	5,08 ±0,25	4,83	5,33