

Quad S—R Latch

The LS279 is a bipolar, NPN, sealed-junction, silicon integrated circuit. It is manufactured in low-power Schottky technology and is available in a wire-bonded, 16-pin plastic DIP or surface mount package.

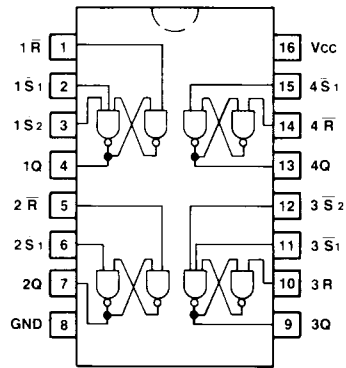

Truth Table

Inputs		Output
$\bar{S}^*$	$\bar{R}$	Q
H	H	Q <sub>0</sub>
L	H	H
H	L	L
L	L	H**

H = High Level

L = Low Level

Q<sub>0</sub> = The level of Q before the indicated input conditions were established

\* = For latches with double  $\bar{S}$  inputs:

H = Both  $\bar{S}$  inputs high

L = One or both  $\bar{S}$  inputs low

\*\* = This output level is pseudo stable; that is, it may not persist when the  $\bar{S}$  and  $\bar{R}$  inputs return to their inactive (high) level

## Electrical Characteristics

VCC = 5.0 ±0.5 V, TA = -55 to +125°C (WA-LS)

VCC = 5.0 ±0.25 V, TA = 0 to 70°C (WP90227L1)

VCC = 5.0 ±0.5 V, TA = -40 to +85°C (WA-LSD, WP91402L4)

Parameter	Symbol	WA-LS		WP, WA-LSD		Units
		Min	Max	Min	Max	
Output Voltage, VCC = 4.5 V (WA-LS), 4.75 V (WP, WA-LSD)						
Low, IOL = 4.0 mA	VOL	—	0.4	—	0.4	V
IOL = 8.0 mA	VOL	—	0.5	—	0.5	V
High, IOH = -0.4 mA	VOH	2.5	—	2.7	—	V
Input Voltage, VCC = 4.5 V (WA-LS), 4.75 V (WP, WA-LSD)						
Low	VIL	—	0.7	—	0.8*	V
High	VIH	2.0	7.5	2.0	5.5	V
Clamp, IIN = -18.0 mA	VIK	—	-1.5	—	-1.5	V
Input Current, VCC = 5.5 V (WA-LS), 5.25 V (WP, WA-LSD)						
Low, VIL = 0.4 V	IIL	—	-0.4	—	-0.4	mA
High, VIH = 2.7 V	IiH	—	20.0	—	20.0	μA
@ Vi max, Vi = 7.0 V (WA-LS), 5.5 V (WP, WA-LSD)	Ii	—	0.1	—	0.1	mA
Output Current, VCC = 5.5 V (WA-LS), 5.25 V (WP, WA-LSD)						
Short-Circuit	Ios	-20.0	-100.0	-20.0	-100.0	mA
Supply Current, VCC = 5.5 V (WA-LS), 5.25 V (WP, WA-LSD)						
Outputs Open, S Inputs High, R Inputs Low	Icc	—	7.0	—	7.0	mA

\* WA-LSD, WP91402L4: VIL = 0.7 V

## Timing Characteristics

VCC = 5.0 V, TA = 25°C, CL = 15 pF

Parameter	Symbol	WA-LS		WP, WA-LSD		Units
		Min	Max	Min	Max	
Propagation Delay						
S Input-to-Output						
Low-to-High	tPLH	—	22.0	—	22.0	ns
High-to-Low	tPHL	—	21.0	—	21.0	ns
R Input-to-Output						
High-to-Low	tPHL	—	27.0	—	27.0	ns

## Maximum Ratings

Power supply voltage (VCC) ..... 7.0 V

Operating temperature (TA) ..... WA-LS: -55 to +125°C

WP90227L1: 0 to 70°C

WA-LSD, WP91402L4: -40 to +85°C

Storage temperature (Tstg) ..... -65 to +150°C

Maximum ratings are defined as the limiting conditions that the user can apply to the device under all variations of circuit and environmental conditions. If any rating is exceeded, permanent damage to the device may result.

Bonding or soldering of the external leads of this device can be performed safely at temperatures up to 300°C.