

MPS3702**PNP EPITAXIAL SILICON TRANSISTOR****AMPLIFIER TRANSISTOR**

- Collector-Emitter Voltage: $V_{CE0} = 25V$
- Collector Dissipation: $P_c (\text{max}) = 625mW$

ABSOLUTE MAXIMUM RATINGS ($T_a = 25^\circ C$)

Characteristic	Symbol	Rating	Unit
Collector-Base Voltage	V_{CBO}	40	V
Collector-Emitter Voltage	V_{CEO}	25	V
Emitter-Base Voltage	V_{EBO}	5	V
Collector Current	I_C	600	mA
Collector Dissipation	P_C	625	mW
Junction Temperature	T_J	150	$^\circ C$
Storage Temperature	T_{stg}	$-55 \sim 150$	$^\circ C$

T-29-21

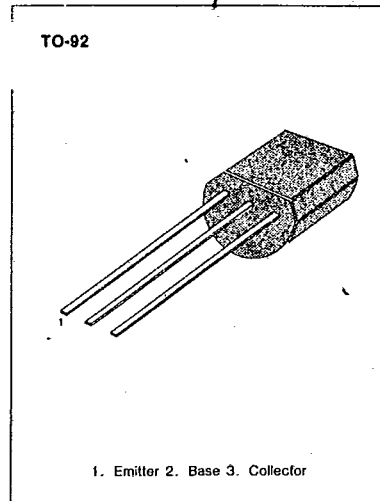
**ELECTRICAL CHARACTERISTICS ($T_a = 25^\circ C$)**

Characteristic	Symbol	Test Conditions	Min	Typ	Max	Unit
Collector-Base Breakdown Voltage	BV_{CBO}	$I_C = 100\mu A, I_E = 0$	40			V
*Collector-Emitter Breakdown Voltage	BV_{CEO}	$I_C = 10mA, I_B = 0$	25			V
Emitter-Base Breakdown Voltage	BV_{EBO}	$I_E = 100\mu A, I_C = 0$	5			V
Collector Cut-off Current	I_{CBO}	$V_{CB} = 20V, I_E = 0$			100	nA
Emitter Cut-off Current	I_{EBO}	$V_{BE} = 3V, I_C = 0$			100	nA
*DC Current Gain	h_{FE}	$I_C = 50mA, V_{CE} = 5V$	60		300	
*Collector-Emitter Saturation Voltage	$V_{CE} (\text{sat})$	$I_C = 50mA, I_B = 5mA$			0.25	V
Output Capacitance	C_{ob}	$V_{CB} = 10V, I_E = 0$ $f = 1MHz$			12	pF
Current Gain Bandwidth Product	f_T	$I_C = 50mA, V_{CE} = 5V$ $f = 20MHz$	100			MHz
• Base-Emitter On Voltage	$V_{BE} (\text{on})$	$I_C = 50mA, V_{CE} = 5V$	0.6		1	V

* Pulse Test: Pulse Width $\leq 300\mu s$, Duty Cycle $\leq 2\%$ 

MPS3702

PNP EPITAXIAL SILICON TRANSISTOR

T-29-21

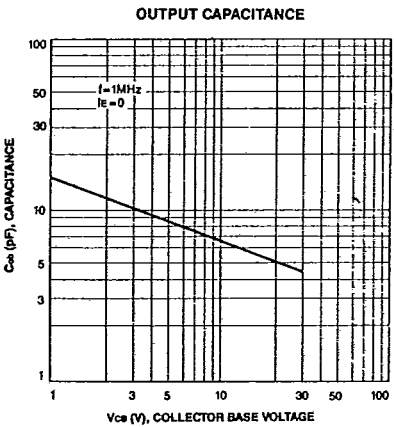
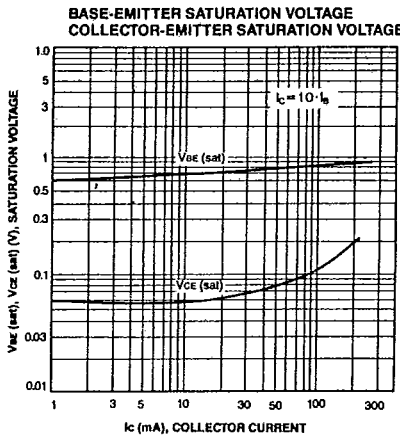
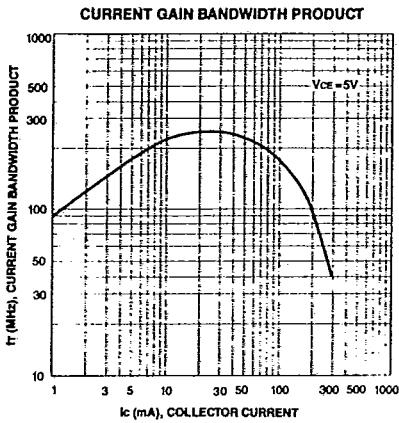
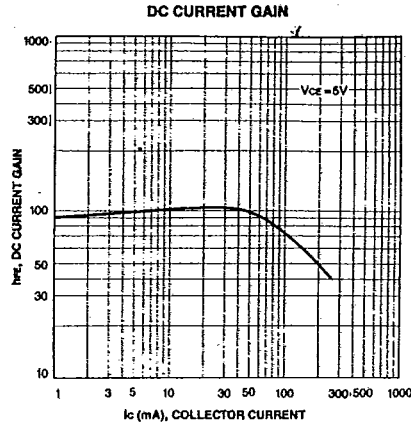
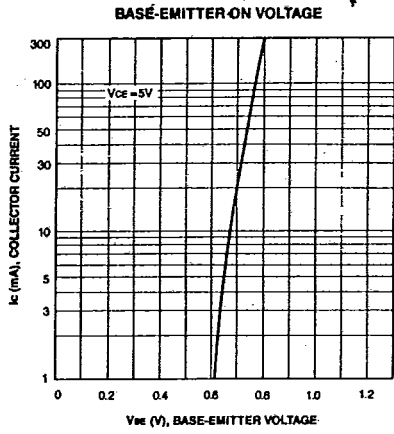

3

T91-20

PACKAGE DIMENSIONS

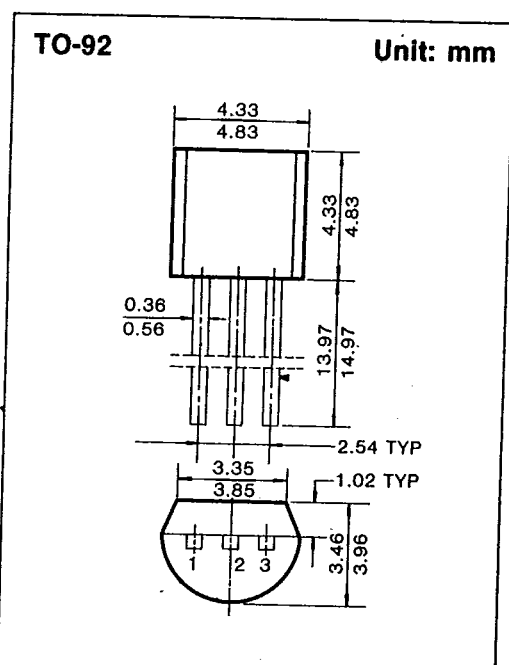
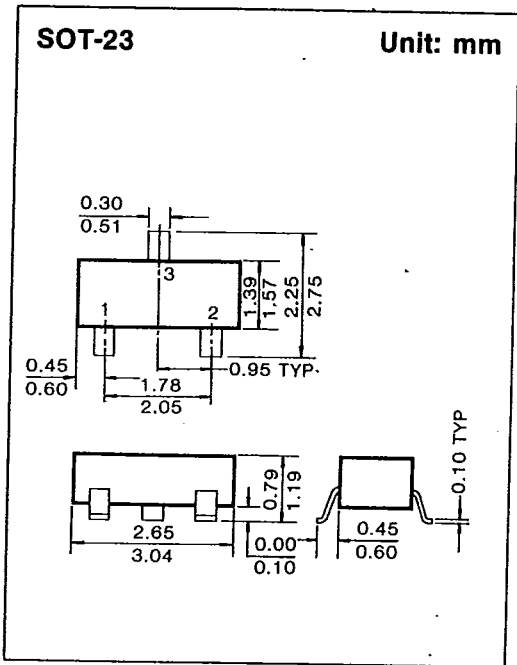

4

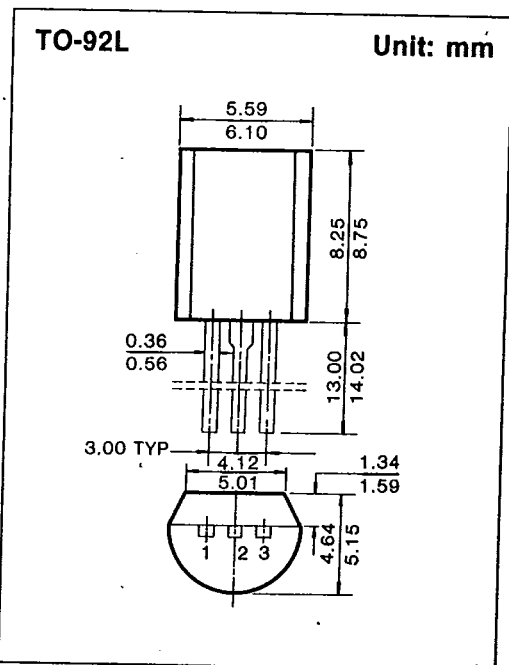
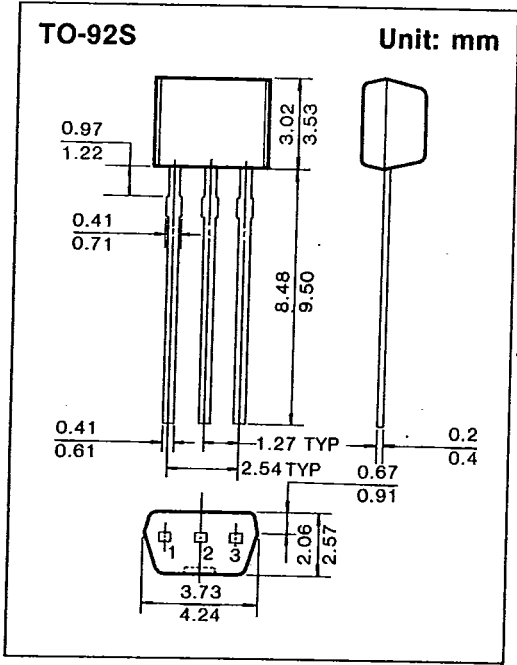

PACKAGE DIMENSIONS

T-91-20

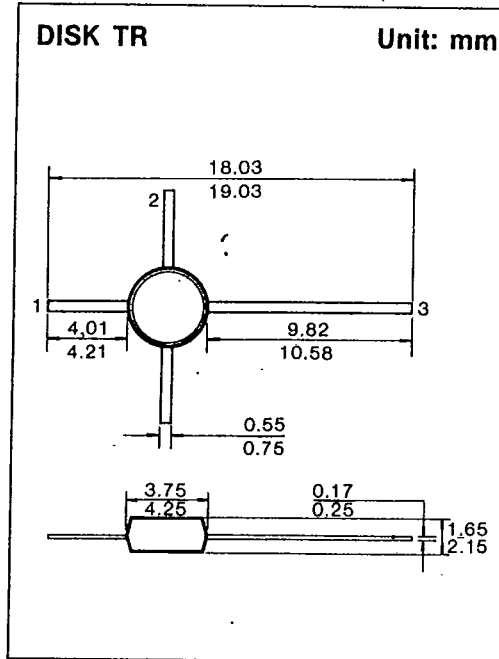
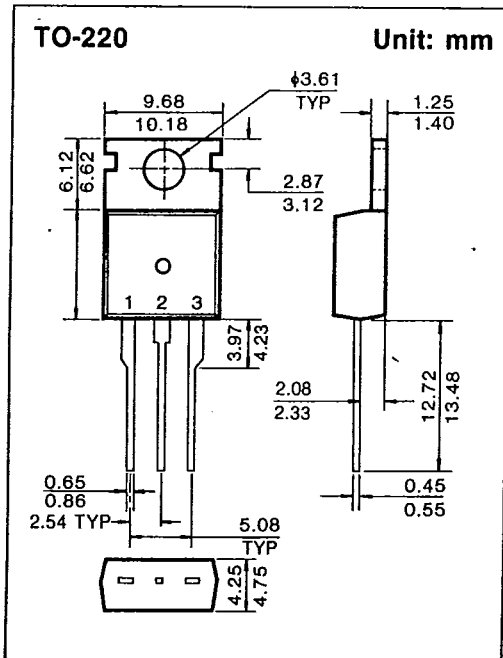
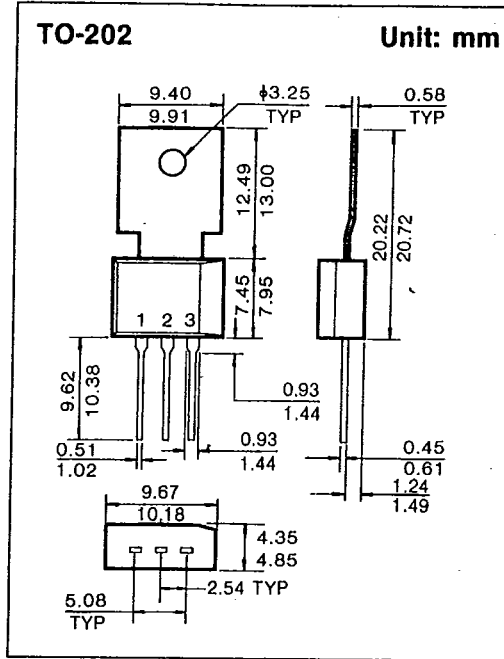
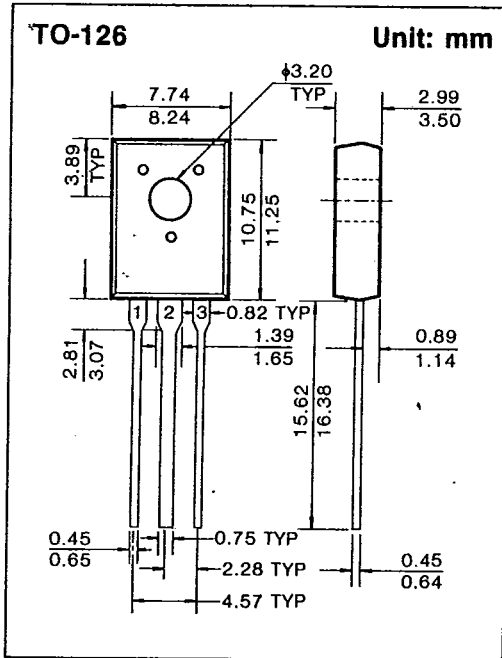

PACKAGE DIMENSIONS

T-91-20

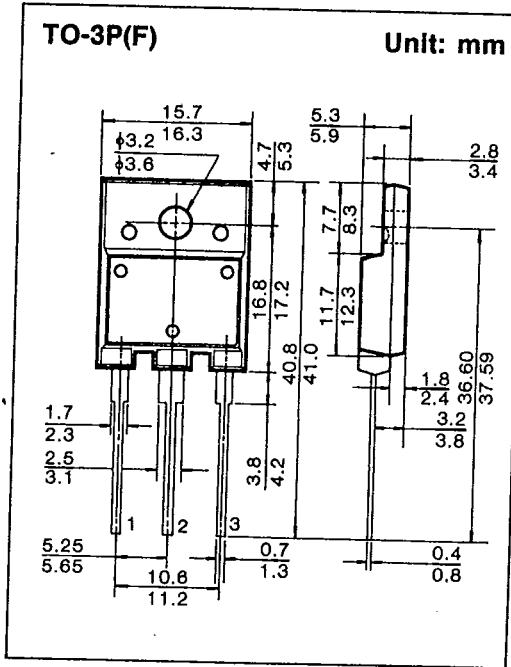
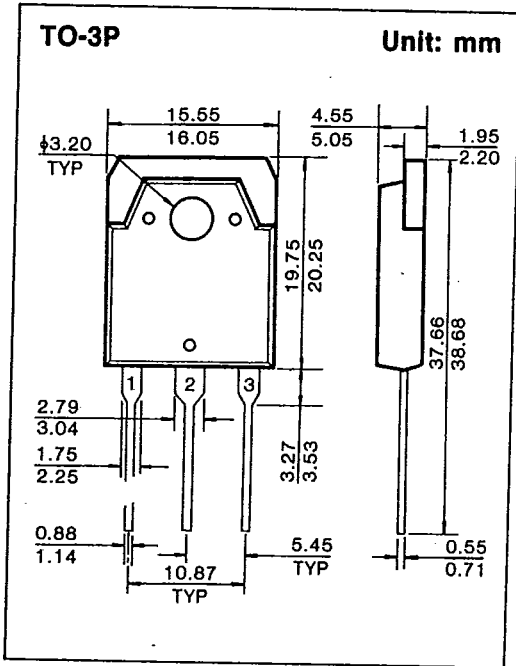

4

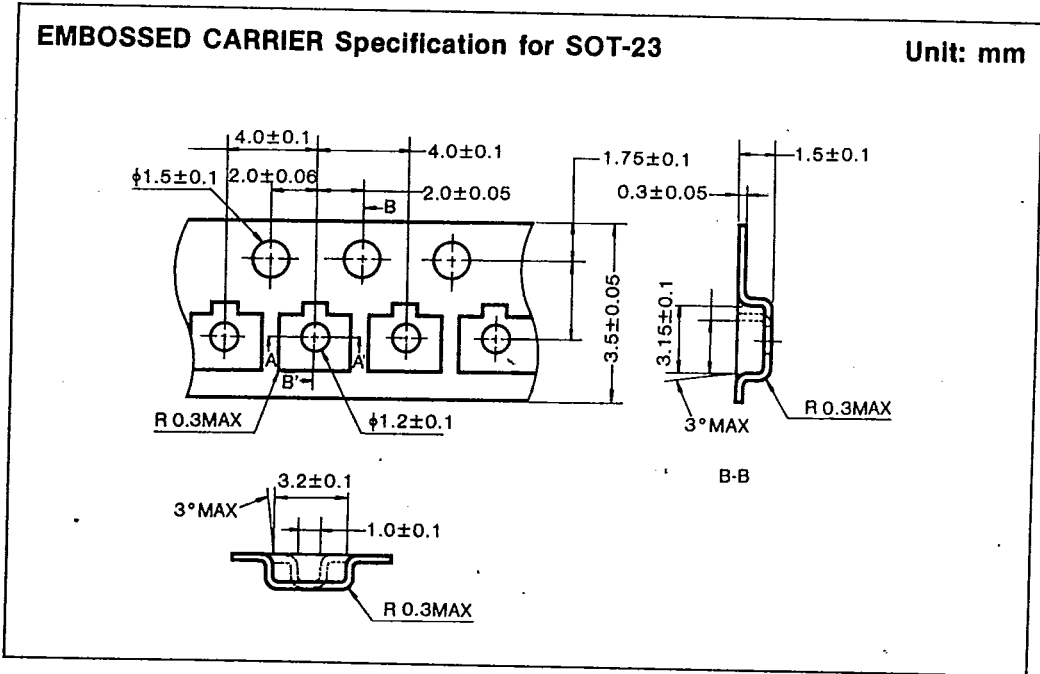

PACKAGE DIMENSIONS

T-91-20

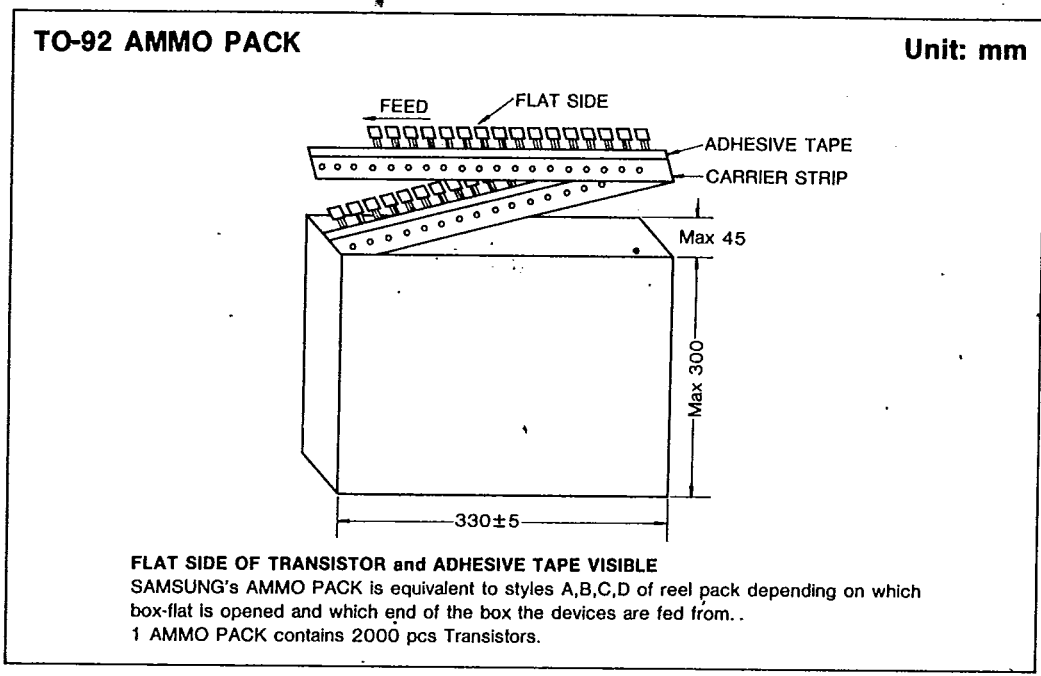

4