

# Large Area InGaAs PIN Photodiodes

## Linear above 20 dBm Input Power

### Features

#### Electro-Optical

- InGaAs PIN Photodiode with high responsivity at 1300 and 1550 nm
- 17 dB attenuation neutral density filter
- $\pm 0.15$  dB linearity to power  $> 20$  dBm
- Proprietary, low noise PIN diode structure
- 1 and 2 mm active diameters

#### Packaging

- Hermetically sealed TO package
- Absorption filter on internal side of TO window

- Chip centered to  $\pm 125$   $\mu\text{m}$  relative to header

### Applications

- Optical power meters: 1300 and 1550 nm
- YAG laser test equipment
- Fiber amplifier test gear
- Optical bench instrumentation

### Specifications

Conditions (unless noted): 25°C,  $V_R = 0\text{V}$

Model	ETX 10LIN24-T5			ETX 20LIN22-T5			
Parameter	Min.	Typ.	Max.	Min.	Typ.	Max.	Units
Active Diameter		1.0			2.0		mm
Responsivity @ 1300 nm <sup>1</sup>	8.5	18	29.5	8.5	18	29.5	$\mu\text{A}/\text{mW}$
Responsivity @ 1550 nm <sup>2</sup>	9.5	19.0	33	9.5	19.0	33	$\mu\text{A}/\text{mW}$
Saturation power @ 1300 nm <sup>3,4</sup>	24.0	26.0	29.0	22.2	24.0	27.0	dBm
Saturation power @ 1300 nm <sup>3,4</sup>	24.2	26.2	29.2	22.4	24.2	27.2	dBm
Shunt Resistance <sup>6</sup>	2.0	50		0.8	3.0		$\text{M}\Omega$
Dark Current <sup>7</sup>		50			900		nA
Total Capacitance		100	150		400	600	pF
Bandwidth <sup>8</sup>		35			5.3		MHz
Sensitivity <sup>2</sup>		-38	-36		-38.5	-36.5	dBm
Field of View <sup>9</sup>		15			15		degrees
Reflectance			10			10	%

#### NOTES

<sup>1</sup> Measured at 300  $\mu\text{W}$  nominal input power.

<sup>2</sup> Can be measured as an option.

<sup>3</sup> Saturation power is defined in accordance with Bellcore advisory #TA-NWT-001092. Saturation power is the upper optical power limit at which the deviation from the median linear range of the L-I curve (see Figure 1) is greater than  $\pm 0.15$  dB.

<sup>4</sup> Value given for shipped device computed from measured values of power at which unfiltered photodiode saturates and of absorption of filter.

<sup>5</sup> Computed value available as an option.

<sup>6</sup>  $V_R = 10$  mV.

<sup>7</sup>  $V_R = 5$  V for ETX 10LIN24-T5;  $V_R = 1$  V for ETX 20LIN22-T5.

<sup>8</sup> -3 dB point into a 50  $\Omega$  load.

<sup>9</sup> Angle of incidence at which responsivity decreases 10% relative to normal.

**Maximum Ratings**

Parameter	ETX 10LIN24-T5	ETX20LIN22-T5	Units
Reverse Voltage	20	2	V
Reverse Current <sup>A</sup>	10	10	mA
Forward Current <sup>B</sup>	10	10	mA
Power Dissipation	100	50	mW
Operating Temperature	-40 / +85	-40 / +85	°C
Storage Temperature	-40 / +85	-40 / +85	°C

**Notes:**

<sup>A</sup> Under reverse bias, current at which device may be damaged.

<sup>B</sup> Under forward bias, current at which device may be damaged.

**Figure 1**

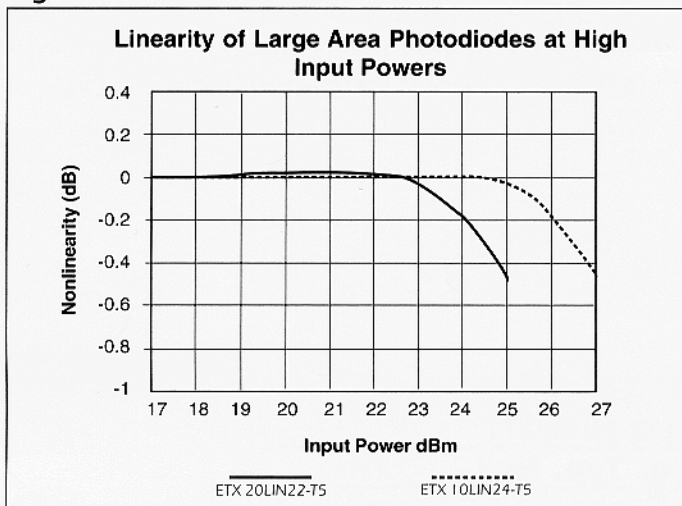

**Figure 2**

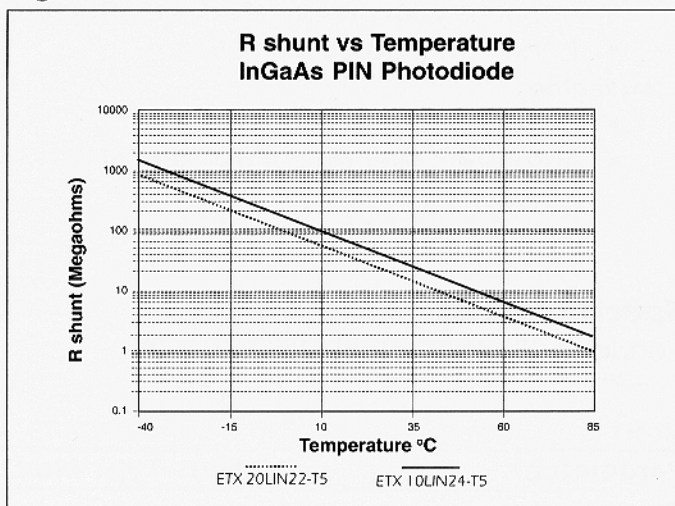

**ETX 10LIN24-T5, ETX 20LIN22-T5**

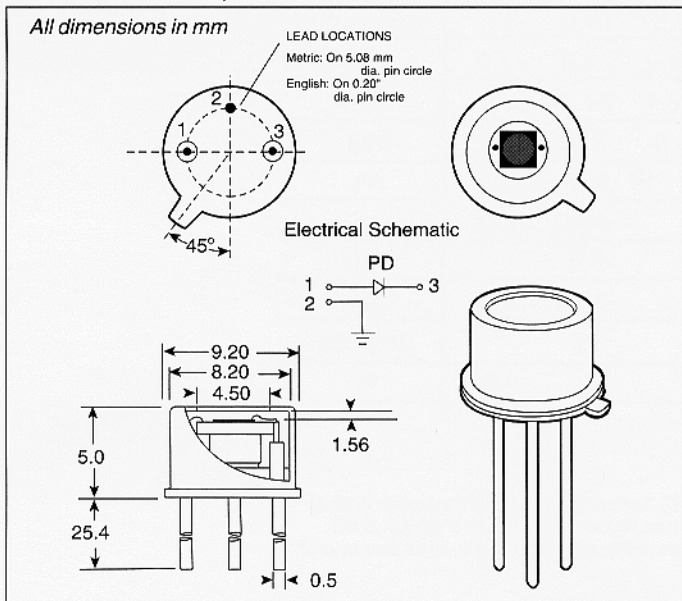

EPITAXX, Inc. believes the information contained in this document to be accurate. However, no responsibility is assumed for its use nor for any infringement of the rights of third parties. EPITAXX, Inc. reserves the right to introduce changes without notice.



**OPTOELECTRONIC DEVICES**

**Corporate Headquarters**

7 Graphics Drive • West Trenton, NJ 08628  
 TEL (609) 538-1800 • FAX (609) 538-1684