

Am25LS09

Quad Two-Input, High-Speed Register

DISTINCTIVE CHARACTERISTICS

- 4-bit register accepts data from one-of-two 4-bit input fields
- Edge triggered clock action
- Second sourced by T.I. as 54LS/74LS399
- Am25LS D.C. parameters including:
 - $V_{OL} = 0.45V$ at $I_{OL} = 8mA$
 - Fan-out over military range = 22
 - 440 μA source current

GENERAL DESCRIPTION

The Am25LS09 is a dual port four-bit register using advanced Low Power Schottky technology to reduce the effect of transistor storage time. The register consists of four D flip-flops with a buffered common clock, and a two-input multiplexer at the input of each flip-flop. A common select line, S, controls the four multiplexers. Data on the

four inputs selected by the S line is stored in the four flip-flops at the clock LOW-to-HIGH transition. When the S input is LOW, the D_{1A} input data will be stored in the register. When the S input is HIGH, the D_{1B} input data will be stored in the register.

BLOCK DIAGRAM

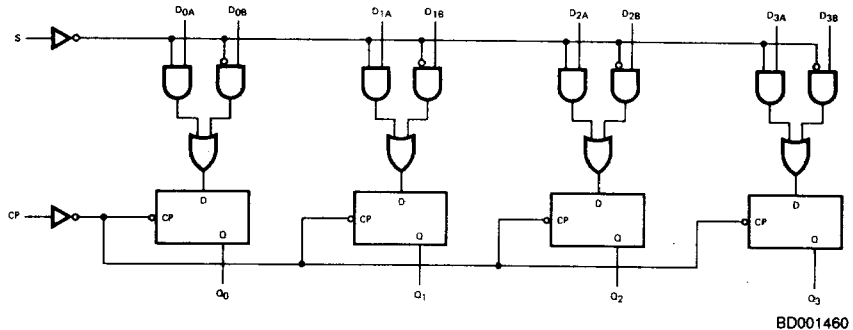

RELATED PRODUCTS

Part No.	Description
Am25S09	High Speed Register
Am25S07/08	6/4-Bit Registers
Am25LS07/08	6/4-Bit Low Power Registers

CONNECTION DIAGRAM Top View

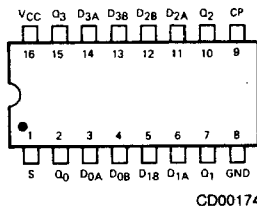

Note: Pin 1 is marked for orientation

LOGIC SYMBOL

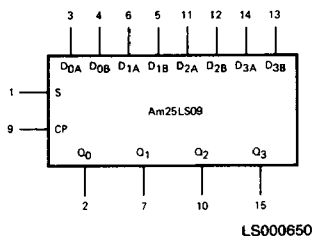

METALLIZATION AND PAD LAYOUT

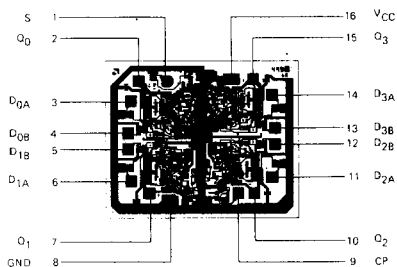

DIE SIZE 0.075" x 0.061"

ORDERING INFORMATION

AMD products are available in several packages and operating ranges. The order number is formed by a combination of the following: Device number, speed option (if applicable), package type, operating range and screening option (if desired).

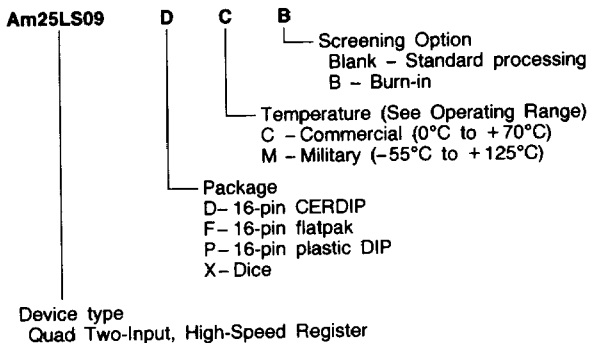

Valid Combinations	
Am25LS09	PC DC, DM FM XC, XM

Valid Combinations
Consult the AMD sales office in your area to determine if a device is currently available in the combination you wish.

PIN DESCRIPTION

Pin No.	Name	I/O	Description
3, 6, 11, 14	D _{0A} , D _{1A} , D _{2A} , D _{3A}	I	The "A" word into the two-input multiplexer of the D flip-flops.
4, 5, 12, 13	D _{0B} , D _{1B} , D _{2B} , D _{3B}	I	The "B" word into the two-input multiplexer of the D flip-flops.
	Q ₀ , Q ₁ , Q ₂ , Q ₃	O	The outputs of the four D-type flip-flops of the register.
1	S	I	Select. When the select is LOW, the A word is applied to the D inputs of the flip-flops. When the select is HIGH the B word is applied to the D inputs of the flip-flops.
9	CP	I	Clock Pulse. Clock pulse for the register. Enters data on the LOW-to-HIGH transition of the clock line.

FUNCTION TABLE

SELECT S	CLOCK CP	DATA D _{1A}	INPUTS D _{1B}	OUTPUT Q _i
L	↑	L	X	L
L	↑	H	X	H
H	↑	X	L	L
H	↑	X	H	H

H = HIGH Voltage Level L = LOW Voltage Level
 X = Don't Care i = 0, 1, 2, or 3
 ↑ = LOW-to-HIGH Transition

APPLICATIONS

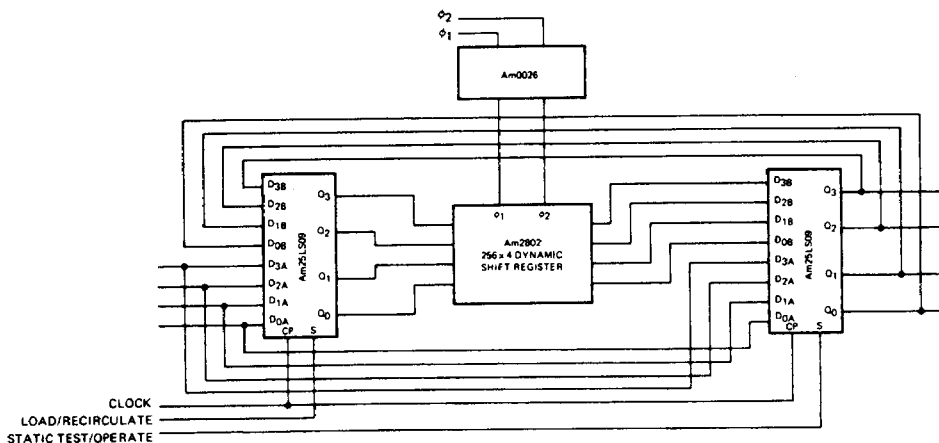

AF001210

Am25LS09 used in 258 x 4 memory system with load/recirculate control, and 1 x 4 static test capability for the system. MOS interface is one load at each end. This circuit is especially useful in digital filtering where special algorithms require a static single step operation for testing purposes.

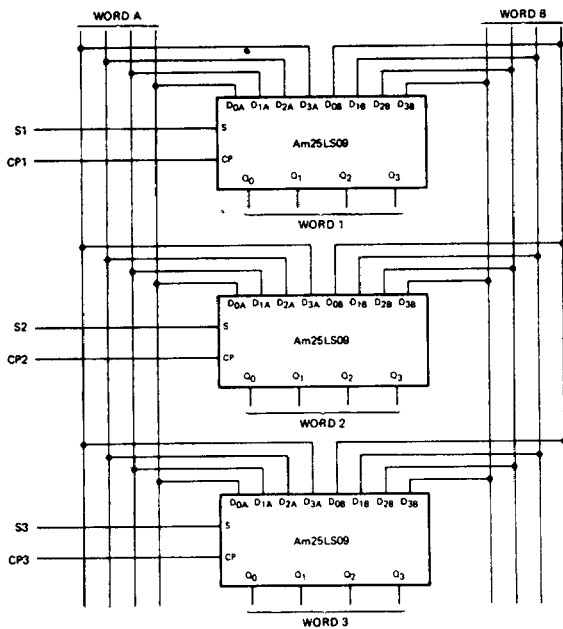

AF001220

Am25LS09 used to store a word from either data bus A or data bus B.

ABSOLUTE MAXIMUM RATINGS

Storage Temperature	-65°C to +150°C
Temperature (Ambient) Under Bias	-55°C to +125°C
Supply Voltage to Ground Potential (Pin 6 to Pin 8) Continuous	-0.5V to +7.0V
DC Voltage Applied to Outputs For High Output State	-0.5V to V_{CC} max
DC Input Voltage	-0.5V to +7.0V
DC Output Current, Into Outputs	30mA
DC Input Current	-30mA to +5.0mA

Stresses above those listed under ABSOLUTE MAXIMUM RATINGS may cause permanent device failure. Functionality at or above these limits is not implied. Exposure to absolute maximum ratings for extended periods may affect device reliability.

OPERATING RANGES

Commercial (C) Devices	
Temperature	0°C to +70°C
Supply Voltage	+4.75V to +5.25V
Military (M) Devices	
Temperature	-55°C to +125°C
Supply Voltage	+4.5V to +5.5V

Operating ranges define those limits over which the functionality of the device is guaranteed.

DC CHARACTERISTICS over operating range unless otherwise specified

Parameters	Description	Test Conditions (Note 2)	Min	Typ (Note 1)	Max	Units	
V_{OH}	Output HIGH Voltage	$V_{CC} = \text{MIN.}, I_{OH} = -440\mu\text{A}$ $V_{IN} = V_{IH}$ or V_{IL}	COM'L	2.7	3.4		Volts
			MIL	2.5	3.4		
V_{OL}	Output LOW Voltage	$V_{CC} = \text{MIN.}$ $V_{IN} = V_{IH}$ or V_{IL}	$I_{OL} = 4\text{mA}$			0.4	Volts
			$I_{OL} = 8\text{mA}$			0.45	
V_{IH}	Input HIGH Level	Guaranteed input logical HIGH voltage for all inputs	2.0			Volts	
V_{IL}	Input LOW Level	Guaranteed input logical LOW voltage for all inputs	MIL			0.7	Volts
			COM'L			0.8	
V_I	Input Clamp Voltage	$V_{CC} = \text{MIN.}, I_{IN} = -18\text{mA}$			-1.5	Volts	
I_{IL}	Input LOW Current	$V_{CC} = \text{MAX.}, V_{IN} = 0.4\text{V}$	Clock, S			-0.36	mA
			Others			-0.24	
I_{IH}	Input HIGH Current	$V_{CC} = \text{MAX.}, V_{IN} = 2.7\text{V}$	Clock, S			20	μA
			Others			14	
I_I	Input HIGH Current	$V_{CC} = \text{MAX.}, V_{IN} = 7.0\text{V}$			0.1	mA	
I_{SC}	Output Short Circuit Current (Note 3)	$V_{CC} = \text{MAX.}$	-15		-85	mA	
I_{CC}	Power Supply Current	$V_{CC} = \text{MAX.}$ (Note 4)		11	18	mA	

- Notes: 1. Typical limits are at $V_{CC} = 5.0\text{V}$, 25°C ambient and maximum loading.
 2. For conditions shown as MIN. or MAX., use the appropriate value specified under Operating Ranges for the applicable device type.
 3. Not more than one output should be shorted at a time. Duration of the short circuit test should not exceed one second.
 4. Measured with Select and Clock inputs at 4.5V; all data inputs at 0V; all outputs open.

SWITCHING CHARACTERISTICS ($T_A = +25^\circ\text{C}$, $V_{CC} = 5.0\text{V}$)

Parameters	Description	Test Conditions	Min	Typ	Max	Units
t_{PLH}	Clock to Q HIGH	$C_L = 15\text{pF}$, $R_L = 2.0\text{k}\Omega$		13	20	ns
t_{PHL}	Clock to Q LOW			13	20	ns
t_{pw}	Clock Pulse Width			17		ns
t_s	Data Set-up Time			20		ns
t_{s_s}	Select Input Set-up Time			30		ns
t_h	Data Hold Time			5		ns
t_{h_s}	Select Input Hold Time			0		ns
f_{max} (Note 1)	Maximum Clock Frequency			40	65	MHz

Note 1. Per industry convention, f_{max} is the worst case value of the maximum device operating frequency with no constraints on t_r , t_f , pulse width or duty cycle.

SWITCHING CHARACTERISTICS over operating range unless otherwise specified*

Parameters	Description	Test Conditions	COMMERCIAL		MILITARY		Units
			Am25LS		Am25LS		
			Min	Max	Min	Max	
t_{PLH}	Clock to Q HIGH	$C_L = 50\text{pF}$, $R_L = 2.0\text{k}\Omega$		30		35	ns
t_{PHL}	Clock to Q LOW			30		35	ns
t_{pw}	Clock Pulse Width		26		30		ns
t_s	Data Set-up Time		30		35		ns
t_{s_s}	Select Input Set-up Time		43		50		ns
t_h	Data Hold Time		11		12		ns
t_{h_s}	Select Input Hold Time		4		5		ns
f_{max} (Note 1)	Maximum Clock Frequency		30		25		MHz

*AC performance over the operating temperature range is guaranteed by testing defined in Group A, Subgroup 9.

Am25LS · Am54LS/74LS
LOW-POWER SCHOTTKY INPUT/OUTPUT
CURRENT INTERFACE CONDITIONS

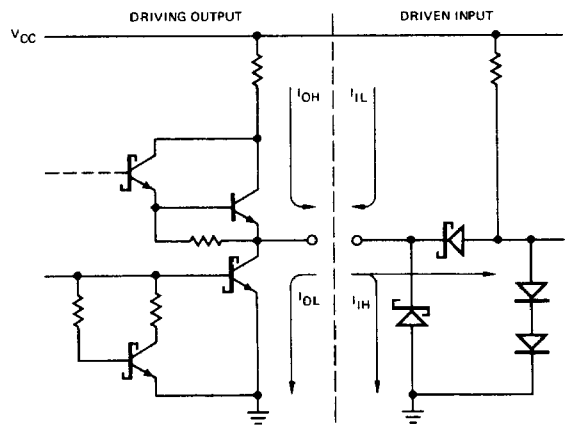

IC000180

Note: Actual current flow direction shown.