

MH28D72AKTG-10,-75,-75A

9,663,676,416-BIT (134,217,728-WORD BY 72-BIT) Double Data Rate Synchronous DRAM Module

DESCRIPTION

The MH28D72AKTG is 134217728 - word x 72-bit Double Data Rate(DDR) Synchronous DRAM mounted module with Mitsubishi original structure.

This consists of 36 pieces 64M x 4 DDR Synchronous DRAMs in Mitsubishi original package with SSTL_2 interface which achieves very high speed data rate up to 133MHz.

This socket-type memory module is suitable for main memory in computer systems and easy to interchange or add modules.

FEATURES

Type name	Clock Rate	
	CL=2 *	CL=2.5 *
MH28D72AKTG-10	100MHz	100MHz
MH28D72AKTG-75	100MHz	133MHz
MH28D72AKTG-75A	133MHz	133MHz

* CL = CAS(Read) Latency

- Utilizes 64M X 4 DDR Synchronous DRAMs in 54pin Mitsubishi original package , industry standard Registered Buffer in 114 ball BGA package , and industry standard PLL in TVSOP package.
- Vdd=Vddq=2.5v ±0.2V
- Double data rate architecture; two data transfers per clock cycle
- Bidirectional, data strobe (DQS) is transmitted/received with data
- Differential clock inputs (CLK and /CLK)
- data referenced to both edges of DQS
- /CAS latency- 2.0/2.5 (programmable)
- Burst length- 2/4/8 (programmable)
- Auto precharge / All bank precharge controlled by A10
- 8192 refresh cycles /64ms
- Auto refresh and Self refresh
- Row address A0-12 / Column address A0-9,11
- SSTL_2 Interface
- Module 2bank Configuration
- Burst Type - sequential/interleave(programmable)
- Commands entered on each positive CLK edge

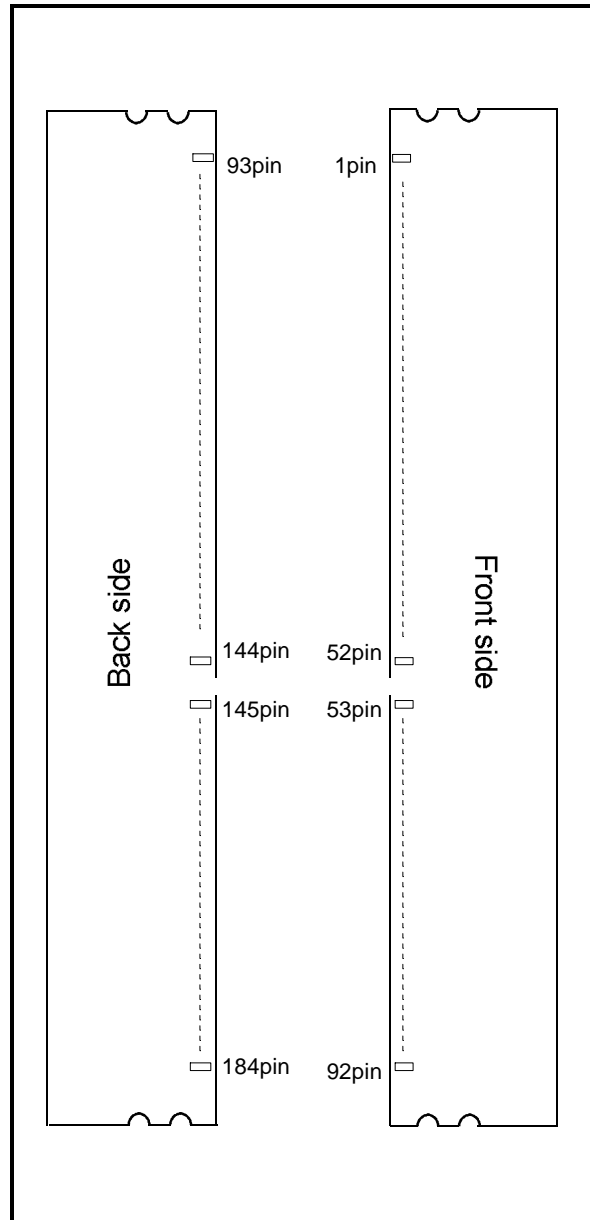

APPLICATION

Main memory unit for PC, PC server, Server, W.S.

MH28D72AKTG-10,-75,-75A

9,663,676,416-BIT (134,217,728-WORD BY 72-BIT) Double Data Rate Synchronous DRAM Module

PIN CONFIGURATION

PIN NO.	PIN NAME	PIN NO.	PIN NAME	PIN NO.	PIN NAME	PIN NO.	PIN NAME	PIN NO.	PIN NAME
1	VREF	43	A1	84	DQ57	126	DQ28	167	NC
2	DQ0	44	CB0	85	VDD	127	DQ29	168	VDD
3	VSS	45	CB1	86	DQS7	128	VDDQ	169	DQS15
4	DQ1	46	VDD	87	DQ58	129	DQS12	170	DQ54
5	DQS0	47	DQS8	88	DQ59	130	A3	171	DQ55
6	DQ2	48	A0	89	VSS	131	DQ30	172	VDDQ
7	VDD	49	CB2	90	NC	132	VSS	173	NC
8	DQ3	50	VSS	91	SDA	133	DQ31	174	DQ60
9	NC	51	CB3	92	SCL	134	CB4	175	DQ61
10	RESET	52	BA1	93	VSS	135	CB5	176	VSS
11	VSS	KEY		94	DQ4	136	VDDQ	177	DQS16
12	DQ8	53	DQ32	95	DQ5	137	CK0	178	DQ62
13	DQ9	54	VDDQ	96	VDDQ	138	/CK0	179	DQ63
14	DQS1	55	DQ33	97	DQS9	139	VSS	180	VDDQ
15	VDDQ	56	DQS4	98	DQ6	140	DQS17	181	SA0
16	NC	57	DQ34	99	DQ7	141	A10	182	SA1
17	NC	58	VSS	100	VSS	142	CB6	183	SA2
18	VSS	59	BA0	101	NC	143	VDDQ	184	VDDSPD
19	DQ10	60	DQ35	102	NC	144	CB7		
20	DQ11	61	DQ40	103	NC	KEY			
21	CKE0	62	VDDQ	104	VDDQ	145	VSS		
22	VDDQ	63	/WE	105	DQ12	146	DQ36		
23	DQ16	64	DQ41	106	DQ13	147	DQ37		
24	DQ17	65	/CAS	107	DQS10	148	VDD		
25	DQS2	66	VSS	108	VDD	149	DQS13		
26	VSS	67	DQS5	109	DQ14	150	DQ38		
27	A9	68	DQ42	110	DQ15	151	DQ39		
28	DQ18	69	DQ43	111	CKE1	152	VSS		
29	A7	70	VDD	112	VDDQ	153	DQ44		
30	VDDQ	71	NC	113	NC	154	/RAS		
31	DQ19	72	DQ48	114	DQ20	155	DQ45		
32	A5	73	DQ49	115	A12	156	VDDQ		
33	DQ24	74	VSS	116	VSS	157	/S0		
34	VSS	75	NC	117	DQ21	158	/S1		
35	DQ25	76	NC	118	A11	159	DQS14		
36	DQS3	77	VDDQ	119	DQS11	160	VSS		
37	A4	78	DQS6	120	VDD	161	DQ46		
38	VDD	79	DQ50	121	DQ22	162	DQ47		
39	DQ26	80	DQ51	122	A8	163	NC		
40	DQ27	81	VSS	123	DQ23	164	VDDQ		
41	A2	82	VDDID	124	VSS	165	DQ52		
42	VSS	83	DQ56	125	A6	166	DQ53		

NC: No Connect

MH28D72AKTG-10,-75,-75A

9,663,676,416-BIT (134,217,728-WORD BY 72-BIT) Double Data Rate Synchronous DRAM Module

Block Diagram

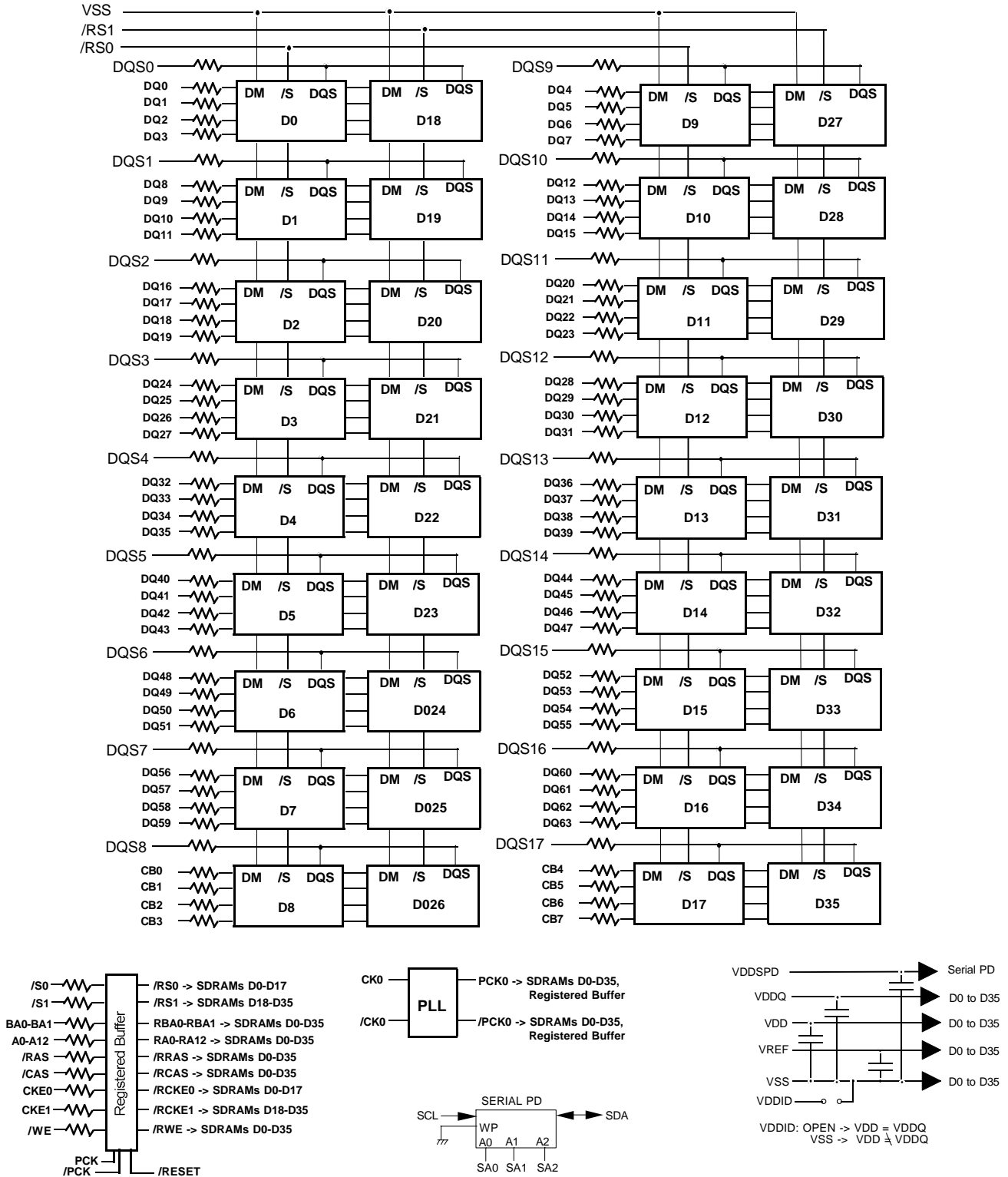

MH28D72AKTG-10,-75,-75A

9,663,676,416-BIT (134,217,728-WORD BY 72-BIT) Double Data Rate Synchronous DRAM Module

PIN FUNCTION

SYMBOL	TYPE	DESCRIPTION
CK0,/CK0	Input	Clock: CK0 and /CK0 are differential clock inputs. All address and control input signals are sampled on the crossing of the positive edge of CK0 and negative edge of /CK0. Output (read) data is referenced to the crossings of CK0 and /CK0 (both directions of crossing).
CKE0, CKE1	Input	Clock Enable: CKE0,1 controls SDRAM internal clock. When CKE0 is low, the internal clock for the following cycle is ceased. CKE0 is also used to select auto / self refresh. After self refresh mode is started, CKE0 becomes asynchronous input. Self refresh is maintained as long as CKE0 is low.
/S0, /S1	Input	Physical Bank Select: When /S0,1 is high, any command means No Operation.
/RAS, /CAS, /WE	Input	Combination of /RAS, /CAS, /WE defines basic commands.
A0-12	Input	A0-12 specify the Row / Column Address in conjunction with BA0,1. The Row Address is specified by A0-12. The Column Address is specified by A0-9,11. A10 is also used to indicate precharge option. When A10 is high at a read / write command, an auto precharge is performed. When A10 is high at a precharge command, all banks are precharged.
BA0,1	Input	Bank Address: BA0,1 specifies one of four banks in SDRAM to which a command is applied. BA0,1 must be set with ACT, PRE, READ, WRITE commands.
DQ 0-63 CB 0-7	Input / Output	Data Input/Output: Data bus
DQS0-17	Input / Output	Data Strobe: Output with read data, input with write data. Edge-aligned with read data, centered in write data. Used to capture write data.
Vdd, VddQ	Power Supply	Power Supply. Vdd and VddQ are connected on the module.
VddQ, VssQ	Power Supply	Power Supply. Vss and VssQ are connected on the module.
Vddspd	Power Supply	Power Supply for SPD
Vref	Input	SSTL_2 reference voltage.
$\overline{\text{RESET}}$	Input	This signal is asynchronous and is driven low to the register in order to guarantee the register outputs are low.
SDA	Input / Output	This bidirectional pin is used to transfer data into or out of the SPD EEPROM. A resistor must be connected from the SDA bus line to VDD to act as a pullup.
SCL	Input	This signal is used to clock data into and out of the SPD EEPROM. A resistor may be connected from the SCL bus time to VDD to act as a pullup.
SA0-2	Input	These signals are tied at the system planar to either VSS or VDD to configure the serial SPD EEPROM address range.
VDDID	—	VDD identification flag

MH28D72AKTG-10,-75,-75A

9,663,676,416-BIT (134,217,728-WORD BY 72-BIT) Double Data Rate Synchronous DRAM Module

BASIC FUNCTIONS

The MH28D72AKTG provides basic functions, bank (row) activate, burst read / write, bank (row) precharge, and auto / self refresh. Each command is defined by control signals of /RAS, /CAS and /WE at CLK rising edge. In addition to 3 signals, /CS, CKE and A10 are used as chip select, refresh option, and precharge option, respectively. To know the detailed definition of commands, please see the command truth table.

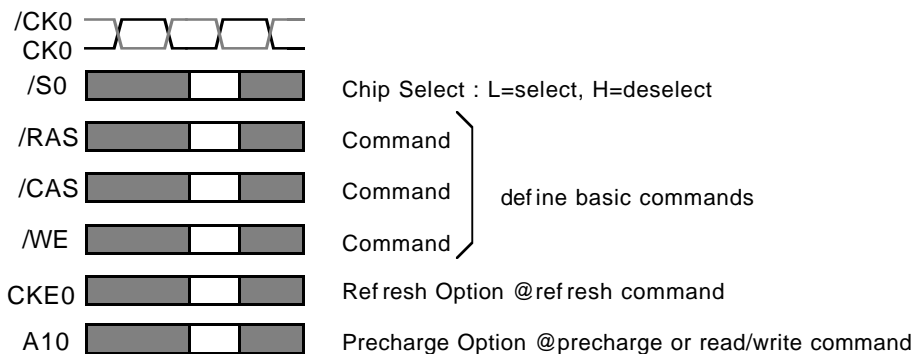

Activate (ACT) [/RAS =L, /CAS =/WE =H]

ACT command activates a row in an idle bank indicated by BA.

Read (READ) [/RAS =H, /CAS =L, /WE =H]

READ command starts burst read from the active bank indicated by BA. First output data appears after /CAS latency. When A10 =H at this command, the bank is deactivated after the burst read (auto-precharge, **READA**)

Write (WRITE) [/RAS =H, /CAS =/WE =L]

WRITE command starts burst write to the active bank indicated by BA. Total data length to be written is set by burst length. When A10 =H at this command, the bank is deactivated after the burst write (auto-precharge, **WRITEA**).

Precharge (PRE) [/RAS =L, /CAS =H, /WE =L]

PRE command deactivates the active bank indicated by BA. This command also terminates burst read /write operation. When A10 =H at this command, all banks are deactivated (precharge all, **PREA**).

Auto-Refresh (REFA) [/RAS =/CAS =L, /WE =CKE0 =H]

REFA command starts auto-refresh cycle. Refresh address including bank address are generated internally. After this command, the banks are precharged automatically.

MH28D72AKTG-10,-75,-75A

9,663,676,416-BIT (134,217,728-WORD BY 72-BIT) Double Data Rate Synchronous DRAM Module

COMMAND TRUTH TABLE

COMMAND	MNEMONIC	CKE _{n-1}	CKE _n	/S	/RAS	/CAS	/WE	BA0,1	A10 /AP	A0-9, 11-12	note
Deselect	DESEL	H	X	H	X	X	X	X	X	X	
No Operation	NOP	H	X	L	H	H	H	X	X	X	
Row Address Entry & Bank Activate	ACT	H	X	L	L	H	H	V	V	V	
Single Bank Precharge	PRE	H	X	L	L	H	L	V	L	X	
Precharge All Banks	PREA	H	X	L	L	H	L	X	H	X	
Column Address Entry & Write	WRITE	H	X	L	H	L	L	V	L	V	
Column Address Entry & Write with Auto-Precharge	WRITEA	H	X	L	H	L	L	V	H	V	
Column Address Entry & Read	READ	H	X	L	H	L	H	V	L	V	
Column Address Entry & Read with Auto-Precharge	READA	H	X	L	H	L	H	V	H	V	
Auto-Refresh	REFA	H	H	L	L	L	H	X	X	X	
Self-Refresh Entry	REFS	H	L	L	L	L	H	X	X	X	
Self-Refresh Exit	REFSX	L	H	H	X	X	X	X	X	X	
		L	H	L	H	H	H	X	X	X	
Burst Terminate	TERM	H	X	L	H	H	L	X	X	X	1
Mode Register Set	MRS	H	X	L	L	L	L	L	L	V	2

H=High Level, L=Low Level, V=Valid, X=Don't Care, n=CLK cycle number

NOTE:

1. Applies only to read bursts with autoprecharge disabled; this command is undefined (and should not be used) for read bursts with autoprecharge enabled, and for write bursts.
2. BA0-BA1 select either the Base or the Extended Mode Register (BA0 = 0, BA1 = 0 selects Mode Register; BA0 = 1, BA1 = 0 selects Extended Mode Register; other combinations of BA0-BA1 are reserved; A0-A11 provide the op-code to be written to the selected Mode Register.

MH28D72AKTG-10,-75,-75A

9,663,676,416-BIT (134,217,728-WORD BY 72-BIT) Double Data Rate Synchronous DRAM Module

FUNCTION TRUTH TABLE

Current State	/S	/RAS	/CAS	/WE	Address	Command	Action	Notes
IDLE	H	X	X	X	X	DESEL	NOP	
	L	H	H	H	X	NOP	NOP	
	L	H	H	L	BA	TERM	ILLEGAL	2
	L	H	L	X	BA, CA, A10	READ / WRITE	ILLEGAL	2
	L	L	H	H	BA, RA	ACT	Bank Active, Latch RA	
	L	L	H	L	BA, A10	PRE / PREA	NOP	4
	L	L	L	H	X	REFA	Auto-Refresh	5
	L	L	L	L	Op-Code, Mode-Add	MRS	Mode Register Set	5
ROW ACTIVE	H	X	X	X	X	DESEL	NOP	
	L	H	H	H	X	NOP	NOP	
	L	H	H	L	BA	TERM	NOP	
	L	H	L	H	BA, CA, A10	READ / READA	Begin Read, Latch CA, Determine Auto-Precharge	
	L	H	L	L	BA, CA, A10	WRITE / WRITEA	Begin Write, Latch CA, Determine Auto-Precharge	
	L	L	H	H	BA, RA	ACT	Bank Active / ILLEGAL	2
	L	L	H	L	BA, A10	PRE / PREA	Precharge / Precharge All	
	L	L	L	H	X	REFA	ILLEGAL	
	L	L	L	L	Op-Code, Mode-Add	MRS	ILLEGAL	
READ (Auto- Precharge Disabled)	H	X	X	X	X	DESEL	NOP (Continue Burst to END)	
	L	H	H	H	X	NOP	NOP (Continue Burst to END)	
	L	H	H	L	BA	TERM	Terminate Burst	
	L	H	L	H	BA, CA, A10	READ / READA	Terminate Burst, Latch CA, Begin New Read, Determine Auto-Precharge	3
	L	H	L	L	BA, CA, A10	WRITE WRITEA	ILLEGAL	
	L	L	H	H	BA, RA	ACT	Bank Active / ILLEGAL	2
	L	L	H	L	BA, A10	PRE / PREA	Terminate Burst, Precharge	
	L	L	L	H	X	REFA	ILLEGAL	
	L	L	L	L	Op-Code, Mode-Add	MRS	ILLEGAL	

MH28D72AKTG-10,-75,-75A

9,663,676,416-BIT (134,217,728-WORD BY 72-BIT) Double Data Rate Synchronous DRAM Module

FUNCTION TRUTH TABLE (continued)

Current State	/S	/RAS	/CAS	/WE	Address	Command	Action	Notes
WRITE (Auto-Precharge Disabled)	H	X	X	X	X	DESEL	NOP (Continue Burst to END)	
	L	H	H	H	X	NOP	NOP (Continue Burst to END)	
	L	H	H	L	BA	TERM	ILLEGAL	
	L	H	L	H	BA, CA, A10	READ / READA	Terminate Burst, Latch CA, Begin Read, Determine Auto-Precharge	3
	L	H	L	L	BA, CA, A10	WRITE / WRITEA	Terminate Burst, Latch CA, Begin Write, Determine Auto-Precharge	3
	L	L	H	H	BA, RA	ACT	Bank Active / ILLEGAL	2
	L	L	H	L	BA, A10	PRE / PREA	Terminate Burst, Precharge	
	L	L	L	H	X	REFA	ILLEGAL	
	L	L	L	L	Op-Code, Mode-Add	MRS	ILLEGAL	
READ with AUTO PRECHARGE	H	X	X	X	X	DESEL	NOP (Continue Burst to END)	
	L	H	H	H	X	NOP	NOP (Continue Burst to END)	
	L	H	H	L	BA	TERM	ILLEGAL	
	L	H	L	H	BA, CA, A10	READ / READA	ILLEGAL	
	L	H	L	L	BA, CA, A10	WRITE / WRITEA	ILLEGAL	
	L	L	H	H	BA, RA	ACT	Bank Active / ILLEGAL	2
	L	L	H	L	BA, A10	PRE / PREA	PRECHARGE/ILLEGAL	2
	L	L	L	H	X	REFA	ILLEGAL	
	L	L	L	L	Op-Code, Mode-Add	MRS	ILLEGAL	
WRITE with AUTO PRECHARGE	H	X	X	X	X	DESEL	NOP (Continue Burst to END)	
	L	H	H	H	X	NOP	NOP (Continue Burst to END)	
	L	H	H	L	BA	TERM	ILLEGAL	
	L	H	L	H	BA, CA, A10	READ / READA	ILLEGAL	
	L	H	L	L	BA, CA, A10	WRITE / WRITEA	ILLEGAL	
	L	L	H	H	BA, RA	ACT	Bank Active / ILLEGAL	2
	L	L	H	L	BA, A10	PRE / PREA	PRECHARGE/ILLEGAL	2
	L	L	L	H	X	REFA	ILLEGAL	
	L	L	L	L	Op-Code, Mode-Add	MRS	ILLEGAL	

MH28D72AKTG-10,-75,-75A

9,663,676,416-BIT (134,217,728-WORD BY 72-BIT) Double Data Rate Synchronous DRAM Module

FUNCTION TRUTH TABLE (continued)

Current State	/S	/RAS	/CAS	/WE	Address	Command	Action	Notes
PRE - CHARGING	H	X	X	X	X	DESEL	NOP (Idle after tRP)	
	L	H	H	H	X	NOP	NOP (Idle after tRP)	
	L	H	H	L	BA	TERM	ILLEGAL	2
	L	H	L	X	BA, CA, A10	READ / WRITE	ILLEGAL	2
	L	L	H	H	BA, RA	ACT	ILLEGAL	2
	L	L	H	L	BA, A10	PRE / PREA	NOP (Idle after tRP)	4
	L	L	L	H	X	REFA	ILLEGAL	
	L	L	L	L	Op-Code, Mode-Add	MRS	ILLEGAL	
ROW ACTIVATING	H	X	X	X	X	DESEL	NOP (Row Active after tRCD)	
	L	H	H	H	X	NOP	NOP (Row Active after tRCD)	
	L	H	H	L	BA	TERM	ILLEGAL	2
	L	H	L	X	BA, CA, A10	READ / WRITE	ILLEGAL	2
	L	L	H	H	BA, RA	ACT	ILLEGAL	2
	L	L	H	L	BA, A10	PRE / PREA	ILLEGAL	2
	L	L	L	H	X	REFA	ILLEGAL	
	L	L	L	L	Op-Code, Mode-Add	MRS	ILLEGAL	
WRITE RE- COVERING	H	X	X	X	X	DESEL	NOP	
	L	H	H	H	X	NOP	NOP	
	L	H	H	L	BA	TERM	ILLEGAL	2
	L	H	L	X	BA, CA, A10	READ / WRITE	ILLEGAL	2
	L	L	H	H	BA, RA	ACT	ILLEGAL	2
	L	L	H	L	BA, A10	PRE / PREA	ILLEGAL	2
	L	L	L	H	X	REFA	ILLEGAL	
	L	L	L	L	Op-Code, Mode-Add	MRS	ILLEGAL	

MH28D72AKTG-10,-75,-75A

9,663,676,416-BIT (134,217,728-WORD BY 72-BIT) Double Data Rate Synchronous DRAM Module

FUNCTION TRUTH TABLE (continued)

Current State	/S	/RAS	/CAS	/WE	Address	Command	Action	Notes
RE-FRESHING	H	X	X	X	X	DESEL	NOP (Idle after tRC)	
	L	H	H	H	X	NOP	NOP (Idle after tRC)	
	L	H	H	L	BA	TERM	ILLEGAL	
	L	H	L	X	BA, CA, A10	READ / WRITE	ILLEGAL	
	L	L	H	H	BA, RA	ACT	ILLEGAL	
	L	L	H	L	BA, A10	PRE / PREA	ILLEGAL	
	L	L	L	H	X	REFA	ILLEGAL	
	L	L	L	L	Op-Code, Mode-Add	MRS	ILLEGAL	
MODE REGISTER SETTING	H	X	X	X	X	DESEL	NOP (Idle after tRSC)	
	L	H	H	H	X	NOP	NOP (Idle after tRSC)	
	L	H	H	L	BA	TERM	ILLEGAL	
	L	H	L	X	BA, CA, A10	READ / WRITE	ILLEGAL	
	L	L	H	H	BA, RA	ACT	ILLEGAL	
	L	L	H	L	BA, A10	PRE / PREA	ILLEGAL	
	L	L	L	H	X	REFA	ILLEGAL	
	L	L	L	L	Op-Code, Mode-Add	MRS	ILLEGAL	

ABBREVIATIONS:

H=High Level, L=Low Level, X=Don't Care

BA=Bank Address, RA=Row Address, CA=Column Address, NOP=No Operation

NOTES:

1. All entries assume that CKE0 was High during the preceding clock cycle and the current clock cycle.
2. ILLEGAL to bank in specified state; function may be legal in the bank indicated by BA, depending on the state of that bank.
3. Must satisfy bus contention, bus turn around, write recovery requirements.
4. NOP to bank precharging or in idle state. May precharge bank indicated by BA.
5. ILLEGAL if any bank is not idle.

ILLEGAL = Device operation and/or data-integrity are not guaranteed.

MH28D72AKTG-10,-75,-75A

9,663,676,416-BIT (134,217,728-WORD BY 72-BIT) Double Data Rate Synchronous DRAM Module

FUNCTION TRUTH TABLE for CKE

Current State	CKE _{n-1}	CKE _n	/S	/RAS	/CAS	/WE	Add	Action	Notes
SELF-REFRESH	H	X	X	X	X	X	X	INVALID	1
	L	H	H	X	X	X	X	Exit Self-Refresh (Idle after tRC)	1
	L	H	L	H	H	H	X	Exit Self-Refresh (Idle after tRC)	1
	L	H	L	H	H	L	X	ILLEGAL	1
	L	H	L	H	L	X	X	ILLEGAL	1
	L	H	L	L	X	X	X	ILLEGAL	1
	L	L	X	X	X	X	X	NOP (Maintain Self-Refresh)	1
POWER DOWN	H	X	X	X	X	X	X	INVALID	
	L	H	X	X	X	X	X	Exit Power Down to Idle	
	L	L	X	X	X	X	X	NOP (Maintain Self-Refresh)	
ALL BANKS IDLE	H	H	X	X	X	X	X	Refer to Function Truth Table	2
	H	L	L	L	L	H	X	Enter Self-Refresh	2
	H	L	H	X	X	X	X	Enter Power Down	2
	H	L	L	H	H	H	X	Enter Power Down	2
	H	L	L	H	H	L	X	ILLEGAL	2
	H	L	L	H	L	X	X	ILLEGAL	2
	H	L	L	L	X	X	X	ILLEGAL	2
	L	X	X	X	X	X	X	Refer to Current State =Power Down	2
ANY STATE other than listed above	H	H	X	X	X	X	X	Refer to Function Truth Table	
	H	L	X	X	X	X	X	Begin CLK Suspend at Next Cycle	3
	L	H	X	X	X	X	X	Exit CLK Suspend at Next Cycle	3
	L	L	X	X	X	X	X	Maintain CLK Suspend	

ABBREVIATIONS:

H=High Level, L=Low Level, X=Don't Care

NOTES:

1. CKE0 Low to High transition will re-enable CK0 and other inputs **asynchronously**. A minimum setup time must be satisfied before any command other than EXIT.
2. Power-Down and Self-Refresh can be entered only from the All Banks Idle State.
3. Must be legal command.

MH28D72AKTG-10,-75,-75A

9,663,676,416-BIT (134,217,728-WORD BY 72-BIT) Double Data Rate Synchronous DRAM Module

POWER ON SEQUENCE

Before starting normal operation, the following power on sequence is necessary to prevent a SDRAM from damaged or multifunctioning.

1. Apply VDD and VDDQ before or the same time as VTT & Vref
2. Maintain stable condition for 200us after stable power and CLK, apply NOP or DSEL
3. Issue precharge command for all banks of the device
4. Issue EMRS
5. Issue MRS
6. Issue 2 or more Auto Refresh commands
7. Maintain stable condition for 200 cycle

After these sequence, the SDRAM is idle state and ready for normal operation.

MODE REGISTER

Burst Length, Burst Type and /CAS Latency can be programmed by setting the mode register (MRS). The mode register stores these data until the next MRS command, which may be issued in idle state.

After tMRD from a MRS command, the DDR DIMM is ready for new command.

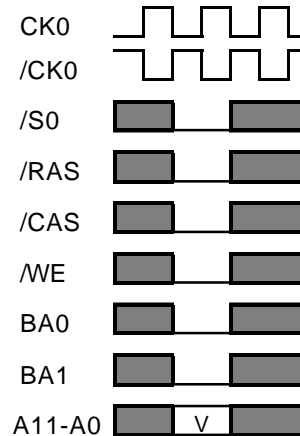

BA1	BA0	A12	A11	A10	A9	A8	A7	A6	A5	A4	A3	A2	A1	A0
-----	-----	-----	-----	-----	----	----	----	----	----	----	----	----	----	----

0	0	0	0	0	0	DR	0	LTMODE	BT	BL
---	---	---	---	---	---	----	---	--------	----	----

Latency Mode *1 (SDRAM level)	CL	/CAS Latency
	0 0 0	R
	0 0 1	R
	0 1 0	2
	0 1 1	R
	1 0 0	R
	1 0 1	R
	1 1 0	2.5
	1 1 1	R

Burst Length	BL	BT= 0	BT= 1
	0 0 0	R	R
	0 0 1	2	2
	0 1 0	4	4
	0 1 1	8	8
	1 0 0	R	R
	1 0 1	R	R
	1 1 0	R	R
	1 1 1	R	R

Burst Type	0	Sequential
	1	Interleaved

R: Reserved for Future Use

DLL	0	NO
Reset	1	YES

*1 In the module, 1latency should be added due to registered DIMM.

MH28D72AKTG-10,-75,-75A

9,663,676,416-BIT (134,217,728-WORD BY 72-BIT) Double Data Rate Synchronous DRAM Module

EXTENDED MODE REGISTER

DLL disable / enable mode can be programmed by setting the extended mode register (EMRS). The extended mode register stores these data until the next EMRS command, which may be issued in idle state. After tMRD from a EMRS command, the DDR DIMM is ready for new command.

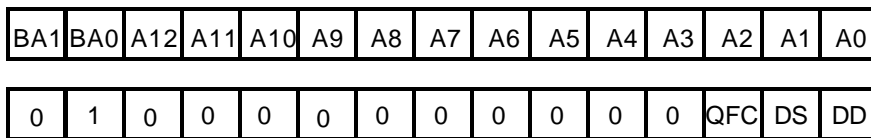
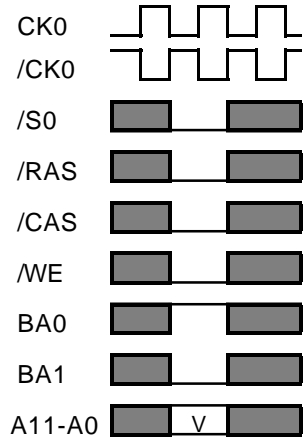

DLL	0	DLL enable
	1	DLL disable

Drive Strength	0	Normal
	1	Weak

QFC	0	Disable
	1	Enable

MH28D72AKTG-10,-75,-75A

9,663,676,416-BIT (134,217,728-WORD BY 72-BIT) Double Data Rate Synchronous DRAM Module

(Component Level)

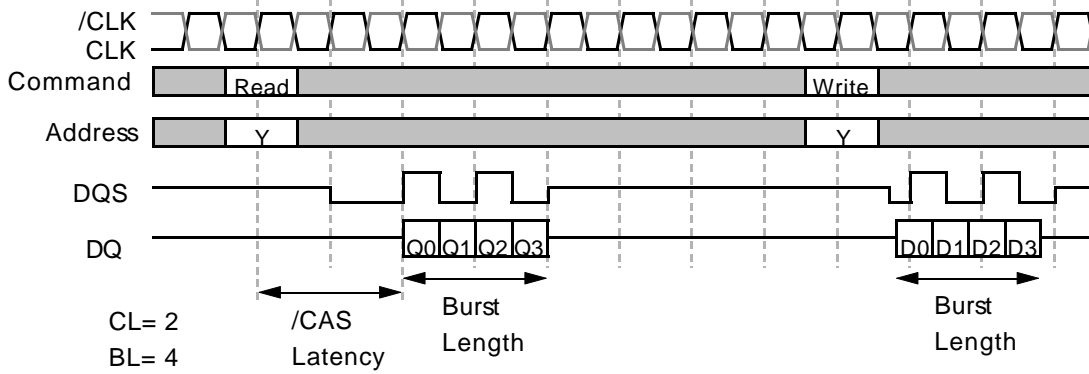

Initial Address			BL	Column Addressing															
A2	A1	A0		Sequential							Interleaved								
0	0	0	8	0	1	2	3	4	5	6	7	0	1	2	3	4	5	6	7
0	0	1		1	2	3	4	5	6	7	0	1	0	3	2	5	4	7	6
0	1	0		2	3	4	5	6	7	0	1	2	3	0	1	6	7	4	5
0	1	1		3	4	5	6	7	0	1	2	3	2	1	0	7	6	5	4
1	0	0		4	5	6	7	0	1	2	3	4	5	6	7	0	1	2	3
1	0	1		5	6	7	0	1	2	3	4	5	4	7	6	1	0	3	2
1	1	0		6	7	0	1	2	3	4	5	6	7	4	5	2	3	0	1
1	1	1		7	0	1	2	3	4	5	6	7	6	5	4	3	2	1	0
-	0	0	4	0	1	2	3					0	1	2	3				
-	0	1		1	2	3	0					1	0	3	2				
-	1	0		2	3	0	1					2	3	0	1				
-	1	1		3	0	1	2					3	2	1	0				
-	-	0	2	0	1							0	1						
-	-	1		1	0							1	0						

MH28D72AKTG-10,-75,-75A

9,663,676,416-BIT (134,217,728-WORD BY 72-BIT) Double Data Rate Synchronous DRAM Module

ABSOLUTE MAXIMUM RATINGS

Symbol	Parameter	Conditions	Ratings	Unit
Vdd	Supply Voltage	with respect to Vss	-0.5 ~ 3.7	V
VddQ	Supply Voltage for Output	with respect to VssQ	-0.5 ~ 3.7	V
VI	Input Voltage	with respect to Vss	-0.5 ~ Vdd+0.5	V
VO	Output Voltage	with respect to VssQ	-0.5 ~ VddQ+0.5	V
IO	Output Current		50	mA
Pd	Power Dissipation	Ta = 25°C	40	W
Topr	Operating Temperature		0 ~ 70	°C
Tstg	Storage Temperature		-40 ~ 100	°C

DC OPERATING CONDITIONS

(Ta=0 ~ 70°C , unless otherwise noted)

Symbol	Parameter	Limits			Unit	Notes
		Min.	Typ.	Max.		
Vdd/VddQ	Supply Voltage	2.3	2.5	2.7	V	
Vref	Input Reference Voltage	0.49*VddQ	0.50*VddQ	0.51*VddQ	V	5
VIH(DC)	High-Level Input Voltage	Vref + 0.15		VddQ+0.3	V	
VIL(DC)	Low-Level Input Voltage	-0.3		Vref - 0.15	V	
VIN(DC)	Input Voltage Level, CK0 and /CK0	-0.3		VddQ + 0.3	V	
VID(DC)	Input Differential Voltage, CK0 and /CK0	0.36		VddQ + 0.6	V	7
VTT	I/O Termination Voltage	Vref - 0.04		Vref + 0.04	V	6

CAPACITANCE

(Ta=0 ~ 70°C , Vdd = VddQ = 2.5 ± 0.2V, Vss = VssQ = 0V, unless otherwise noted)

Symbol	Parameter	Test Condition	Limits(max.)	Unit	Notes
CI(A)	Input Capacitance, address pin	VI - 1.25V f=100MHz VI = 25mV _{rm}	TBD	pF	11
CI(C)	Input Capacitance, control pin		TBD	pF	11
CI(K)	Input Capacitance, CK0 pin		TBD	pF	11
CI/O	Input Capacitance, I/O pin		TBD	pF	11

MH28D72AKTG-10,-75,-75A

9,663,676,416-BIT (134,217,728-WORD BY 72-BIT) Double Data Rate Synchronous DRAM Module

AVERAGE SUPPLY CURRENT from Vdd

(Ta=0 ~ 70°C, Vdd = VddQ = 2.5 ± 0.2V, Vss = VssQ = 0V, Output Open, unless otherwise noted)

Symbol	Parameter/Test Conditions	Limits(max)		Unit	Notes
		-75 / -75A	-10		
IDD0	OPERATING CURRENT: One Bank; Active-Precharge; t RC = t RC MIN; t CK = t CK MIN; DQ, DM and DQS inputs changing twice per clock cycle; address and control inputs changing once per clock cycle	2919	2764	mA	
IDD1	OPERATING CURRENT: One Bank; Active-Read-Precharge; Burst = 2; t RC = t RC MIN; CL = 2.5; t CK = t CK MIN; IOU= 0 mA; Address and control inputs changing once per clock cycle	3009	2854	mA	
IDD2P	PRECHARGE POWER-DOWN STANDBY CURRENT: All banks idle; power-down mode; CKE ≤ VIL (MAX); t CK = t CK MIN	1389	1324	mA	
IDD2N	IDLE STANDBY CURRENT: /CS > VIH (MIN); All banks idle; CKE > VIH (MIN); t CK = t CK MIN; Address and other control inputs changing once per clock cycle	1749	1684	mA	
IDD3P	ACTIVE POWER-DOWN STANDBY CURRENT: One bank active; power-down mode; CKE ≤ VIL (MAX); t CK = t CK MIN	1569	1504	mA	
IDD3N	ACTIVE STANDBY CURRENT: /CS > VIH (MIN); CKE > VIH (MIN); One bank; Active-Precharge; t RC = t RAS MAX; t CK = t CK MIN; DQ,DM and DQS inputs changing twice per clock cycle; address and other control inputs changing once per clock cycle	2109	1954	mA	
IDD4R	OPERATING CURRENT: Burst = 2; Reads; Continuous burst; One bank active; Address and control inputs changing once per clock cycle; CL = 2.5; t CK = t CK MIN; IOU = 0 mA	3729	3484	mA	
IDD4W	OPERATING CURRENT: Burst = 2; Writes; Continuous burst; One bank active; Address and control inputs changing once per clock cycle; CL = 2.5; t CK = t CK MIN; DQ, DM and DQS inputs changing twice per clock cycle	3639	3394	mA	
IDD5	AUTO REFRESH CURRENT: t RC = t RFC (MIN)	6969	6544	mA	
IDD6	SELF REFRESH CURRENT: CKE ≤ 0.2V	417	352	mA	
IDD7	OPERATING CURRENT-Four bank Operation: Four bank interleaving with BL=4, Refer to the Note20	5529	5104	mA	20

AC OPERATING CONDITIONS AND CHARACTERISTICS

(Ta=0 ~ 70°C, Vdd = VddQ = 2.5 ± 0.2V, Vss = VssQ = 0V, unless otherwise noted)

Symbol	Parameter/Test Conditions	Limits		Unit	Notes
		Min.	Max.		
VIH(AC)	High-Level Input Voltage (AC)	Vref + 0.31		V	
VIL(AC)	Low-Level Input Voltage (AC)		Vref - 0.31	V	
VID(AC)	Input Differential Voltage, CLK and /CLK	0.7	V _{DDQ} + 0.6	V	7
VIX(AC)	Input Crossing Point Voltage, CLK and /CLK	0.5*V _{DDQ} -0.2	0.5*V _{DDQ} +0.2	V	8
IOZ	Off-state Output Current /Q floating Vo=0~V _{DDQ}	-5	5	μA	
Ii	Input Current / VIN=0 ~ VddQ	-5	5	μA	

MH28D72AKTG-10,-75,-75A

9,663,676,416-BIT (134,217,728-WORD BY 72-BIT) Double Data Rate Synchronous DRAM Module

AC TIMING REQUIREMENTS (Component Level)

(Ta=0 ~ 70 °C, Vdd = VddQ = 2.5 ± 0.2V, Vss = VssQ = 0V, unless otherwise noted)

AC Characteristics		-75 / -75A		-10			
Symbol	Parameter	Min.	Max.	Min.	Max.	Unit	Notes
tAC	DQ Output Valid data delay time from CLK//CLK	-0.75	+0.75	-0.8	+0.8	ns	
tDQSK	DQ Output Valid data delay time from CLK//CLK	-0.75	+0.75	-0.8	+0.8	ns	
tCH	CLK High level width	0.45	0.55	0.45	0.55	tCK	
tCL	CLK Low level width	0.45	0.55	0.45	0.55	tCK	
tHP	CLK half period	min(tCL,tCH)		min(tCL,tCH)		ns	
tCK	CLK cycle time	CL=2.5	7.5	15	8	15	ns
		CL=2	10 (-75) 7.5(-75A)	15	10	15	ns
tDH	Input Setup time (DQ,DM)	0.5		0.6		ns	
tDS	Input Hold time(DQ,DM)	0.5		0.6		ns	
tDIPW	DQ and DM input pulse width (for each input)	1.75		2		ns	
tHZ	Data-out-high impedance time from CLK//CLK	-0.75	+0.75	-0.8	+0.8	ns	14
tLZ	Data-out-low impedance time from CLK//CLK	-0.75	+0.75	-0.8	+0.8	ns	14
tDQSQ	DQS-DQ Skew(for DQS and associated DQ signals)		+0.5		+0.6	ns	
tQH	DQ/DQS output hold time from DQS	tHP-0.75		tHP-1.0		ns	
tDQSS	Write command to first DQS latching transition	0.75	1.25	0.75	1.25	tCK	
tDQSH	DQS input High level width	0.35		0.35		tCK	
tDQSL	DQS input Low level width	0.35		0.35		tCK	
tDSS	DQS falling edge to CLK setup time	0.2		0.2		tCK	
tDSH	DQS falling edge hold time from CLK	0.2		0.2		tCK	
tMRD	Mode Register Set command cycle time	15		15		ns	
tWPRES	Write preamble setup time	0		0		ns	16
tWPST	Write postamble	0.4	0.6	0.4	0.6	tCK	15
tWPRE	Write preamble	0.25		0.25		tCK	
tIS	Input Setup time (address and control)	0.9		1.1		ns	19
tIH	Input Hold time (address and control)	0.9		1.1		ns	19
tRPST	Read postamble	0.4	0.6	0.4	0.6	tCK	
tRPRE	Read preamble	0.9	1.1	0.9	1.1	tCK	

MH28D72AKTG-10,-75,-75A

9,663,676,416-BIT (134,217,728-WORD BY 72-BIT) Double Data Rate Synchronous DRAM Module

AC TIMING REQUIREMENTS(Continues)

($T_a=0 \sim 70^\circ\text{C}$, $V_{dd} = V_{ddQ} = 2.5 \pm 0.2\text{V}$, $V_{ss} = V_{ssQ} = 0\text{V}$, unless otherwise noted)

AC Characteristics		-75 / -75A		-10			
Symbol	Parameter	Min.	Max.	Min.	Max.	Unit	Notes
tRAS	Row Active time	45	120,000	50	120,000	ns	
tRC	Row Cycle time(operation)	65		70		ns	
tRFC	Auto Ref. to Active/Auto Ref. command period	75		80		ns	
tRCD	Row to Column Delay	20		20		ns	
tRP	Row Precharge time	20		20		ns	
tRRD	Act to Act Delay time	15		15		ns	
tWR	Write Recovery time	15		15		ns	
tDAL	Auto Precharge write recovery + precharge time	35		35		ns	
tWTR	Internal Write to Read Command Delay	1		1		tCK	
tXSNR	Exit Self Ref. to non-Read command	75		80		ns	
tXSRD	Exit Self Ref. to -Read command	200		200		tCK	
tXPNR	Exit Power down to command	1		1		tCK	
tXPRD	Exit Power down to -Read command	1		1		tCK	18
tREFI	Average Periodic Refresh interval	7.8		7.8		us	17

Output Load Condition

(for component measurement)

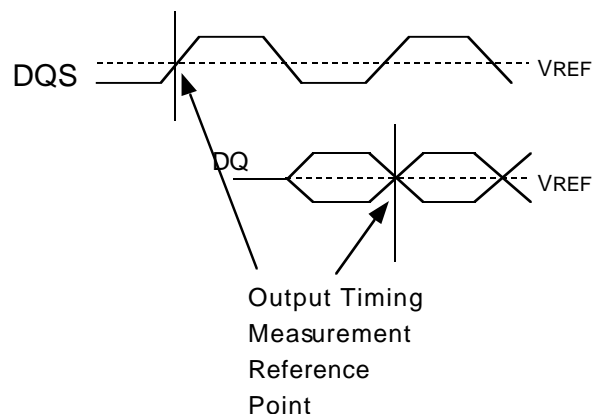
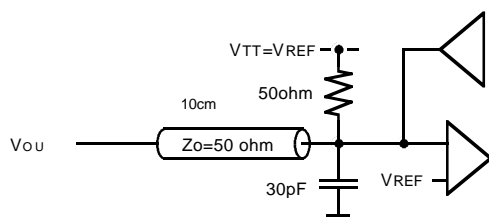

MH28D72AKTG-10,-75,-75A**9,663,676,416-BIT (134,217,728-WORD BY 72-BIT) Double Data Rate Synchronous DRAM Module****Notes**

1. All voltages referenced to Vss.
2. Tests for AC timing, IDD, and electrical, AC and DC characteristics, may be conducted at nominal reference/supply voltage levels, but the related specifications and device operation are guaranteed for the full voltage range specified.
3. AC timing and IDD tests may use a VIL to VIH swing of up to 1.5V in the test environment, but input timing is still referenced to VREF (or to the crossing point for CK//CK), and parameter specifications are guaranteed for the specified AC input levels under normal use conditions. The minimum slew rate for the input signals is 1V/ns in the range between VIL(AC) and VIH(AC).
4. The AC and DC input level specifications are as defined in the SSTL_2 Standard (i.e. the receiver will effectively switch as a result of the signal crossing the AC input level, and will remain in that state as long as the signal does not ring back above (below) the DC input LOW (HIGH) level.
5. VREF is expected to be equal to 0.5*VddQ of the transmitting device, and to track variations in the DC level of the same. Peak-to-peak noise on VREF may not exceed +/-2% of the DC value.
6. VTT is not applied directly to the device. VTT is a system supply for signal termination resistors, is expected to be set equal to VREF, and must track variations in the DC level of VREF.
7. VID is the magnitude of the difference between the input level on CLK and the input level on /CLK.
8. The value of VIX is expected to equal 0.5*VddQ of the transmitting device and must track variations in the DC level of the same.
9. Enables on-chip refresh and address counters.
10. IDD specification are tested after the device is properly initialized.
11. This parameter is sampled. VddQ = +2.5V+/-0.2V, Vdd = +2.5V+/-0.2V, f=100MHz, Ta = 25°C, VOUT(DC)= VddQ/2, VOUT(PEAK TO PEAK) = 25mV, DM inputs are grouped with I/O pins - reflecting the fact that they are matched in loading (to facilitate trace matching at the board level).
12. The CLK//CLK input reference level (for signals other than CLK//CLK) is the point at which CLK and /CLK cross; the input reference level for signals other than CLK//CLK, is VREF.
13. Inputs are not recognized as valid until VREF stabilized. Exception: during the period before VREF stabilizes, CKE=< 0.3VddQ is recognized as LOW.
14. tHZ and tLZ transitions occur in the same access time windows as valid data transitions. These parameters are not referenced to a specific voltage level, but specify when the device output is no longer driving (HZ), or begins driving (LZ).
15. The maximum limit for this parameter is not a device limit. The device will operate with a greater value for this parameter, but system performance (bus turnaround) will degrade accordingly.
16. The specific requirement is that DQS be valid (HIGH, LOW, or at some point on a valid transition) on or before this CLK edge. A valid transition is defined as monotonic, and meeting the input slew rate specifications of the device. When no writes were previously in progress on the bus, DQS will be transitioning from High-Z to logic LOW. If a previous write was in progress, DQS could be HIGH, LOW, or transitioning from HIGH to LOW at this time, depending on tDQSS.
17. A maximum of eight AUTO REFRESH commands can be posted to any given DDR SDRAM device.
18. tXPRD should be 200 tCLK in the condition of the unstable CLK operation during the power down mode.
19. For command/address and CLK & /CLK slew rate $\geq 1.0V/ns$.
20. IDD7 : Operating current: Four Bank
For Bank are being interleaved with tRC(min), Burst Mode, Address and Control inputs on NOP edge are not changing. Iout =0mA
Timing patterns:
tCK = min, tRRD=2*tCK, BL=4, tRCD=3*tCK, Read with Autoprecharge
Read:A0 N A1 R0 A2 R1 N R3 A0 N A0 N A1 R0 - repeat the same timing with random address changing
*100% of data changing at every burst
Abbrev. : A=Activate, R=Read, P=Precharge, N=NOP

MH28D72AKTG-10,-75,-75A

9,663,676,416-BIT (134,217,728-WORD BY 72-BIT) Double Data Rate Synchronous DRAM Module

(Component Level)

Read Operation

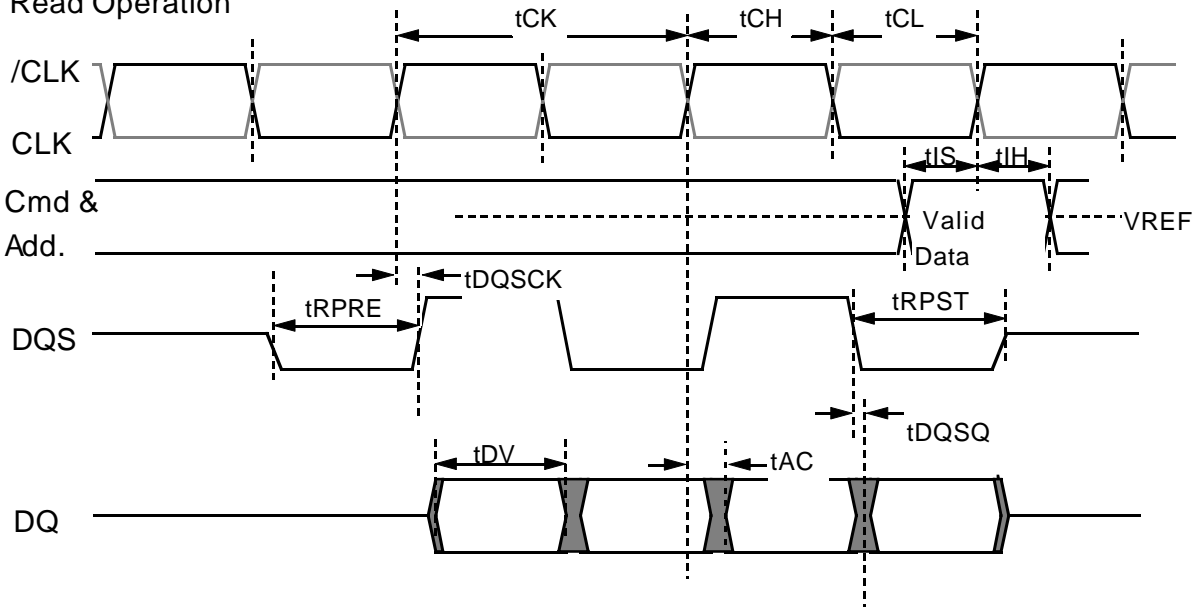

Write Operation / $t_{\text{DQSS}}=\text{max.}$

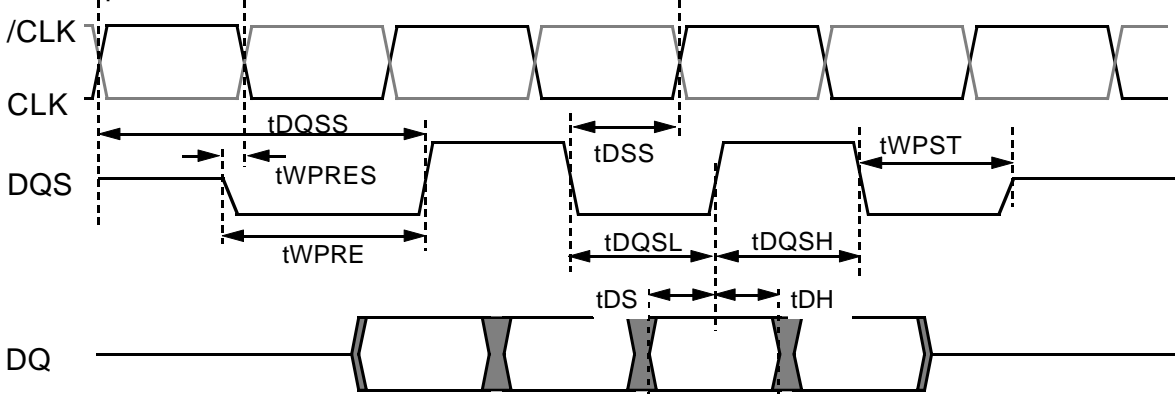

Write Operation / $t_{\text{DQSS}}=\text{min.}$

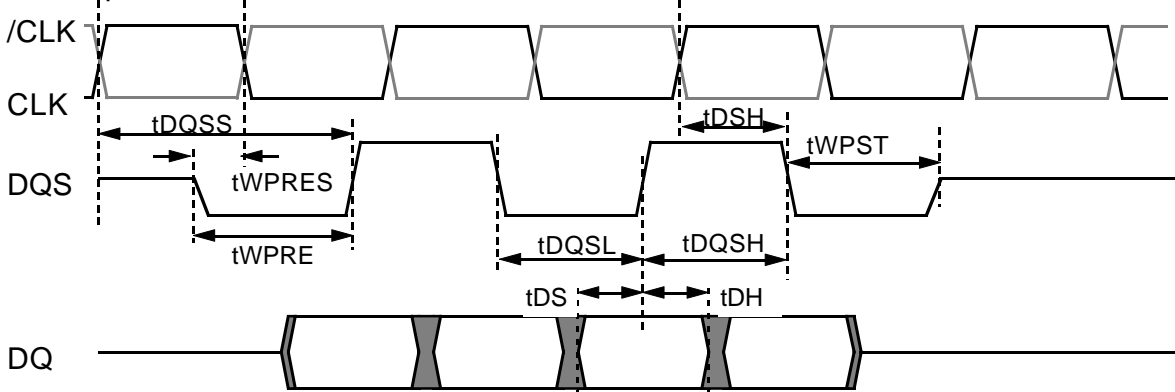

MH28D72AKTG-10,-75,-75A

9,663,676,416-BIT (134,217,728-WORD BY 72-BIT) Double Data Rate Synchronous DRAM Module

OPERATIONAL DESCRIPTION

BANK ACTIVATE

The DDR SDRAM has four independent banks. Each bank is activated by the ACT command with the bank addresses (BA0,1). A row is indicated by the row address A12-0. The minimum activation interval between one bank and the other bank is tRRD. Maximum 2 ACT commands are allowed within tRC, although the number of banks which are active concurrently is not limited.

PRECHARGE

The PRE command deactivates the bank indicated by BA0,1. When multiple banks are active, the precharge all command (PREA,PRE+A10=H) is available to deactivate them at the same time. After tRP from the precharge, an ACT command to the same bank can be issued.

Bank Activation and Precharge All (BL=8, CL=2 (Discrete level))

Module input and output timing.

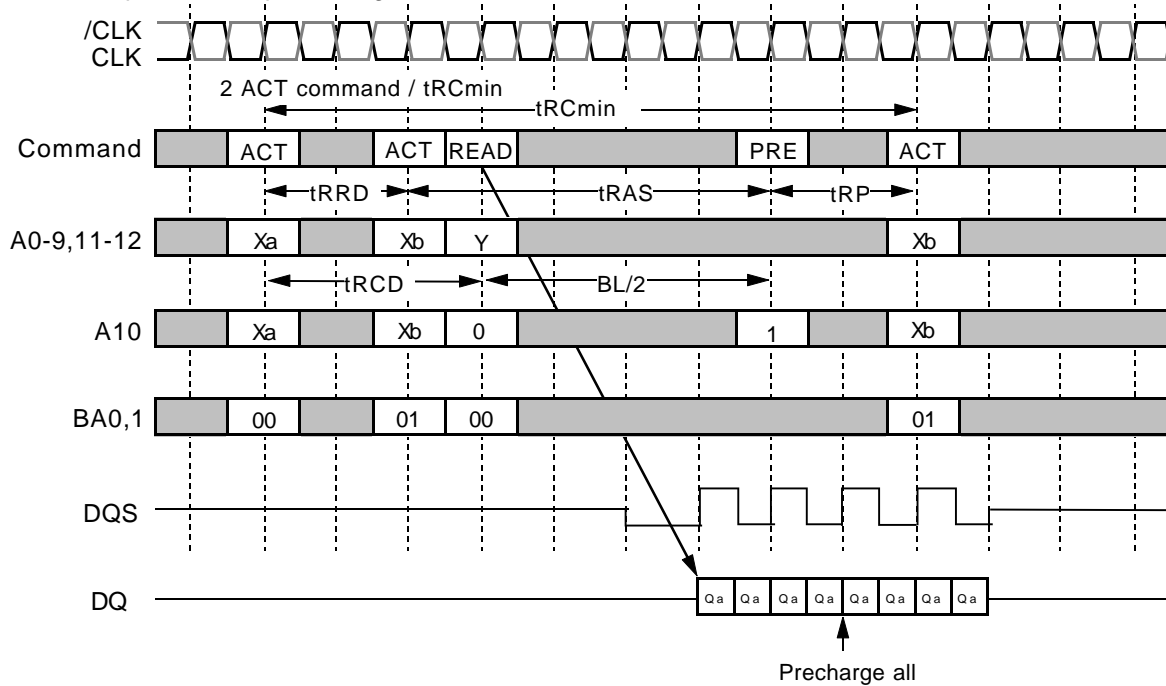

A precharge command can be issued at BL/2(Discrete) from a read command without data loss.

MH28D72AKTG-10,-75,-75A

9,663,676,416-BIT (134,217,728-WORD BY 72-BIT) Double Data Rate Synchronous DRAM Module

READ

After tRCD from the bank activation, a READ command can be issued. 1st Output data is available after the /CAS Latency from the READ, followed by (BL-1) consecutive data when the Burst Length is BL. The start address is specified by A11,A9-A0, and the address sequence of burst data is defined by the Burst Type. A READ command may be applied to any active bank, so the row precharge time (tRP) can be hidden behind continuous output data by interleaving the multiple banks. When A10 is high at a READ command, the auto-precharge(READA) is performed. Any command(READ,WRITE,PRE,ACT) to the same bank is inhibited till the internal precharge is complete. The internal precharge starts at BL/2(Discrete, In case of module, BL/2+1) after READA. The next ACT command can be issued after (BL/2+tRP) from the previous READA.

Multi Bank Interleaving READ (BL=8, CL=2(Discrete level))

Module input and output timing.

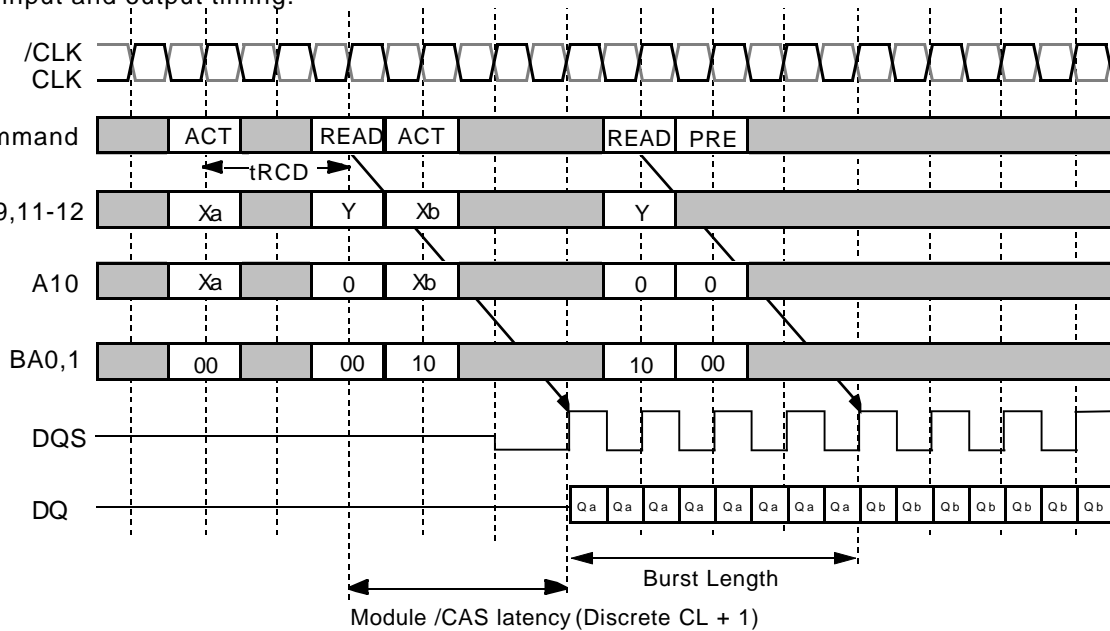

MH28D72AKTG-10,-75,-75A

9,663,676,416-BIT (134,217,728-WORD BY 72-BIT) Double Data Rate Synchronous DRAM Module

READ with Auto-Precharge (BL=8, CL=2(Discrete))

Module input and output timing.

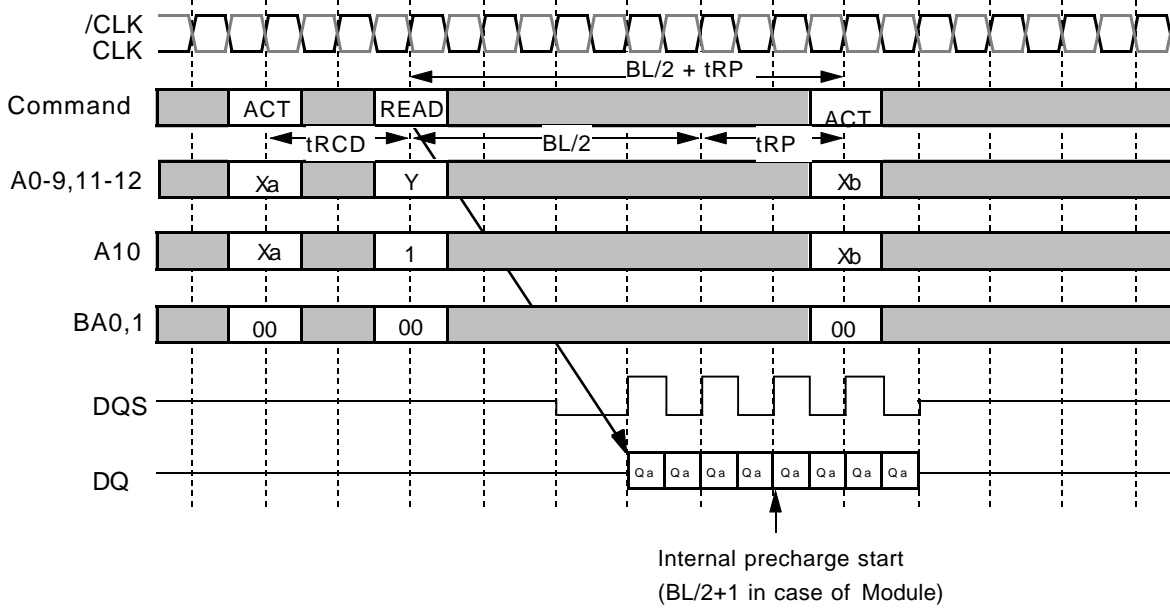

READ Auto-Precharge Timing (BL=8)

Module input and output timing.

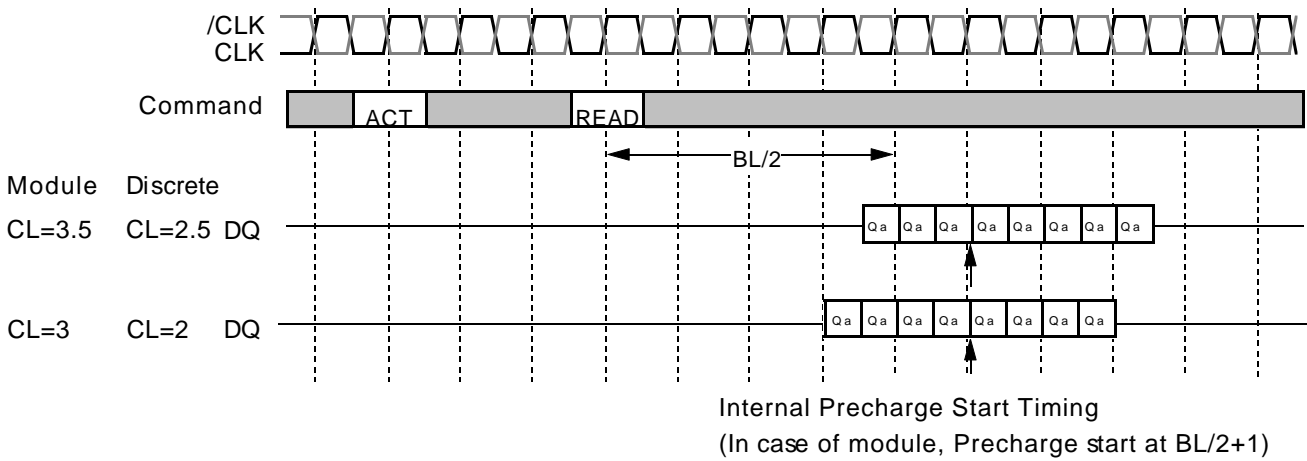

MH28D72AKTG-10,-75,-75A

9,663,676,416-BIT (134,217,728-WORD BY 72-BIT) Double Data Rate Synchronous DRAM Module

WRITE

After t_{RCD} from the bank activation, a WRITE command can be issued. 1st input data is set from the WRITE command with data strobe input, following (BL-1) data are written into RAM, when the Burst Length is BL. The start address is specified by A11,A9-A0, and the address sequence of burst data is defined by the Burst Type. A WRITE command may be applied to any active bank, so the row precharge time (t_{RP}) can be hidden behind continuous input data by interleaving the multiple banks. From the last data to the PRE command, the write recovery time (t_{WRP}) is required. When A10 is high at a WRITE command, the auto-precharge(WRITEEA) is performed. Any command(READ,WRITE,PRE,ACT) to the same bank is inhibited till the internal precharge is complete. The next ACT command can be issued after t_{DAL} from the last input data cycle.

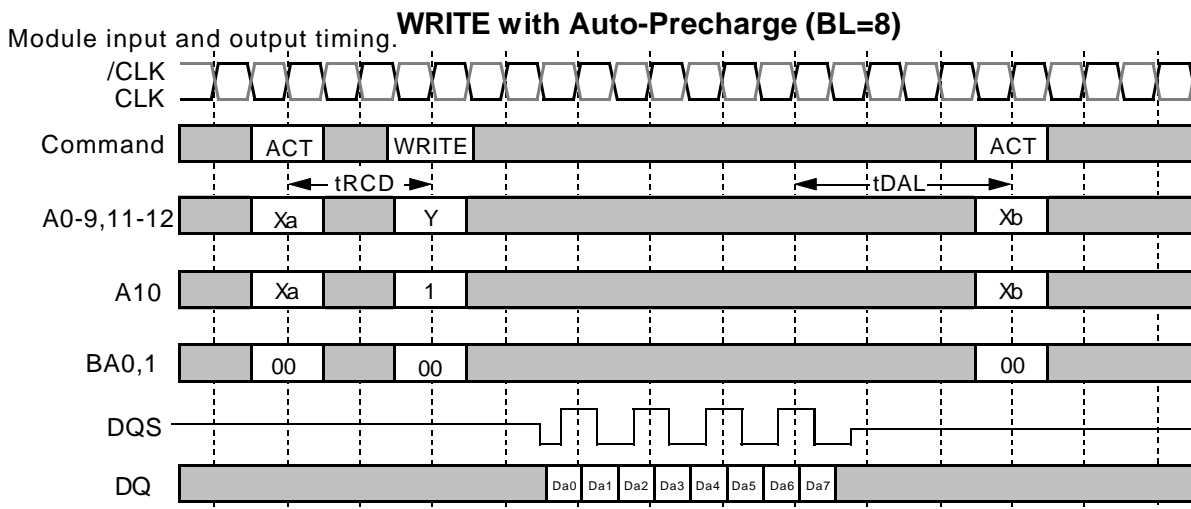
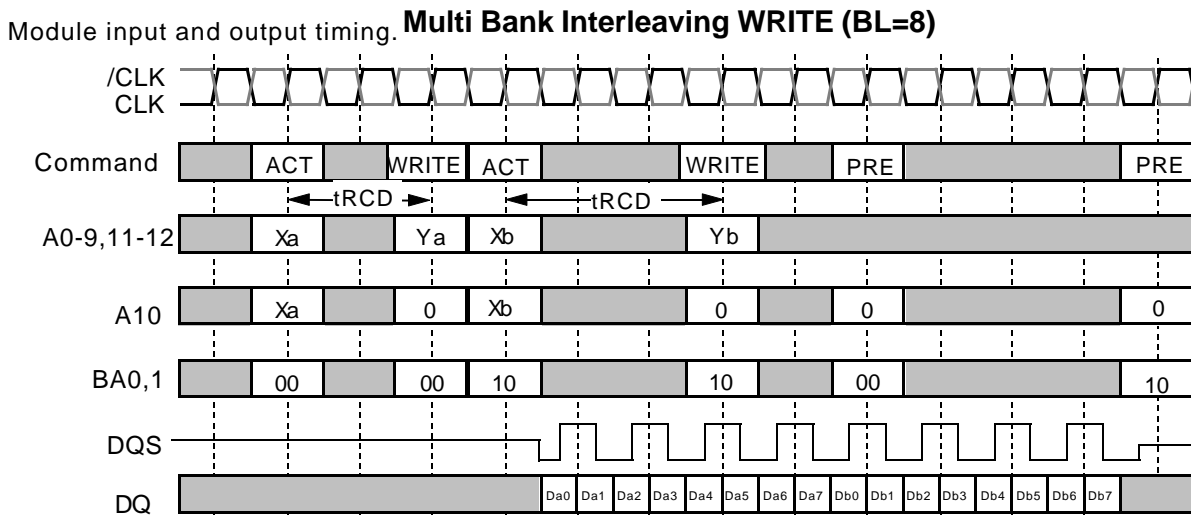

MH28D72AKTG-10,-75,-75A

9,663,676,416-BIT (134,217,728-WORD BY 72-BIT) Double Data Rate Synchronous DRAM Module

BURST INTERRUPTION

[Read Interrupted by Read]

Burst read operation can be interrupted by new read of any bank. Random column access is allowed. READ to READ interval is minimum 1CLK.

Module input and output timing. **Read Interrupted by Read (BL=8, CL=2(Discrete))**

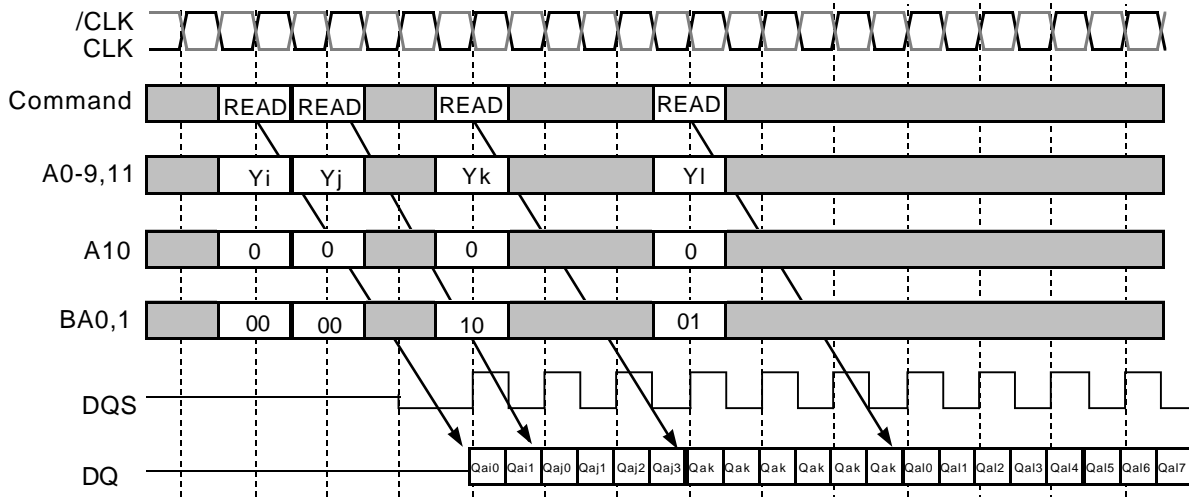

[Read Interrupted by precharge]

Burst read operation can be interrupted by precharge of the same bank. READ to PRE interval is minimum 1 CLK. A PRE command to output disable latency is equivalent to the /CAS Latency. As a result, READ to PRE interval determines valid data length to be output. The figure below shows examples of BL=8.

Read Interrupted by Precharge (BL=8)

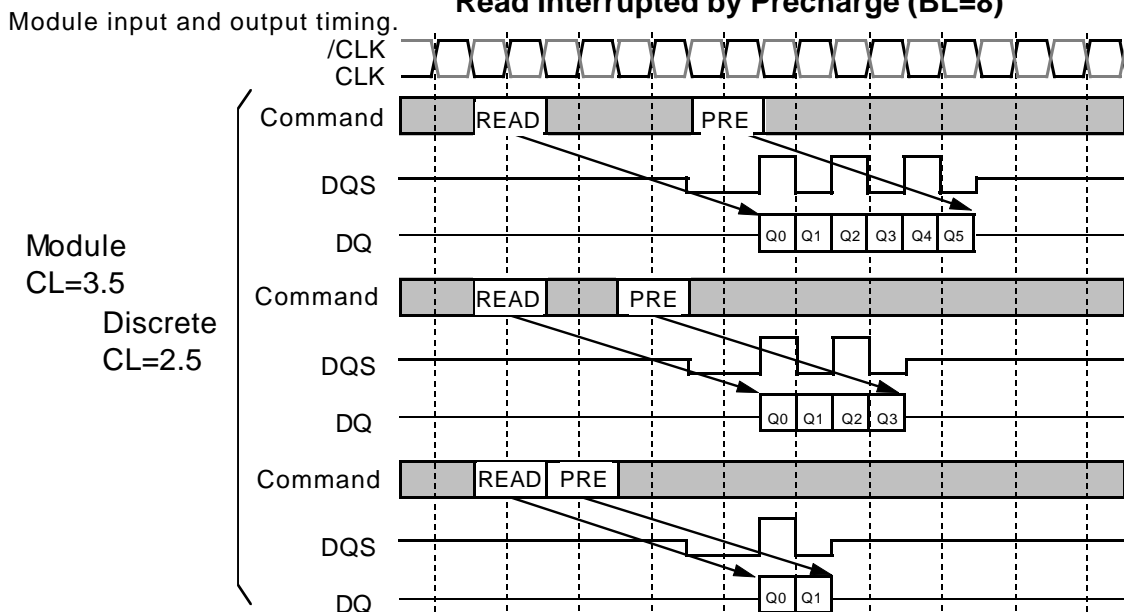

MH28D72AKTG-10,-75,-75A

9,663,676,416-BIT (134,217,728-WORD BY 72-BIT) Double Data Rate Synchronous DRAM Module

Module input and output timing. **Read Interrupted by Precharge (BL=8)**

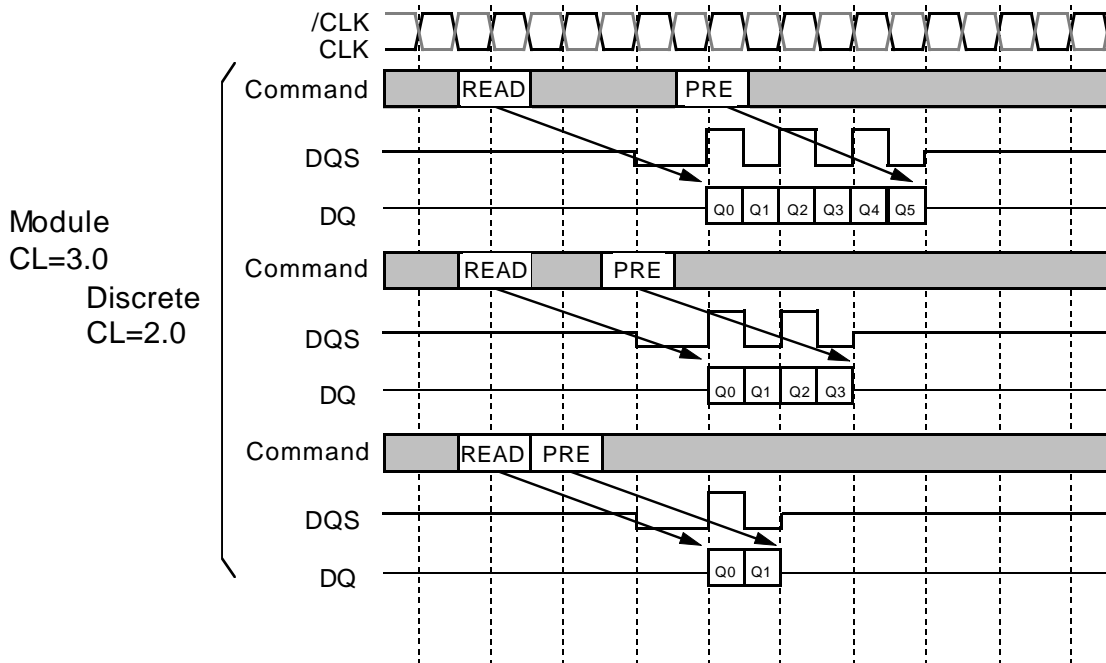

MH28D72AKTG-10,-75,-75A

9,663,676,416-BIT (134,217,728-WORD BY 72-BIT) Double Data Rate Synchronous DRAM Module

[Read Interrupted by Burst Stop]

Burst read operation can be interrupted by a burst stop command (TERM). READ to TERM interval is minimum 1 CLK. A TERM command to output disable latency is equivalent to the /CAS Latency. As a result, READ to TERM interval determines valid data length to be output. The figure below shows examples of BL=8.

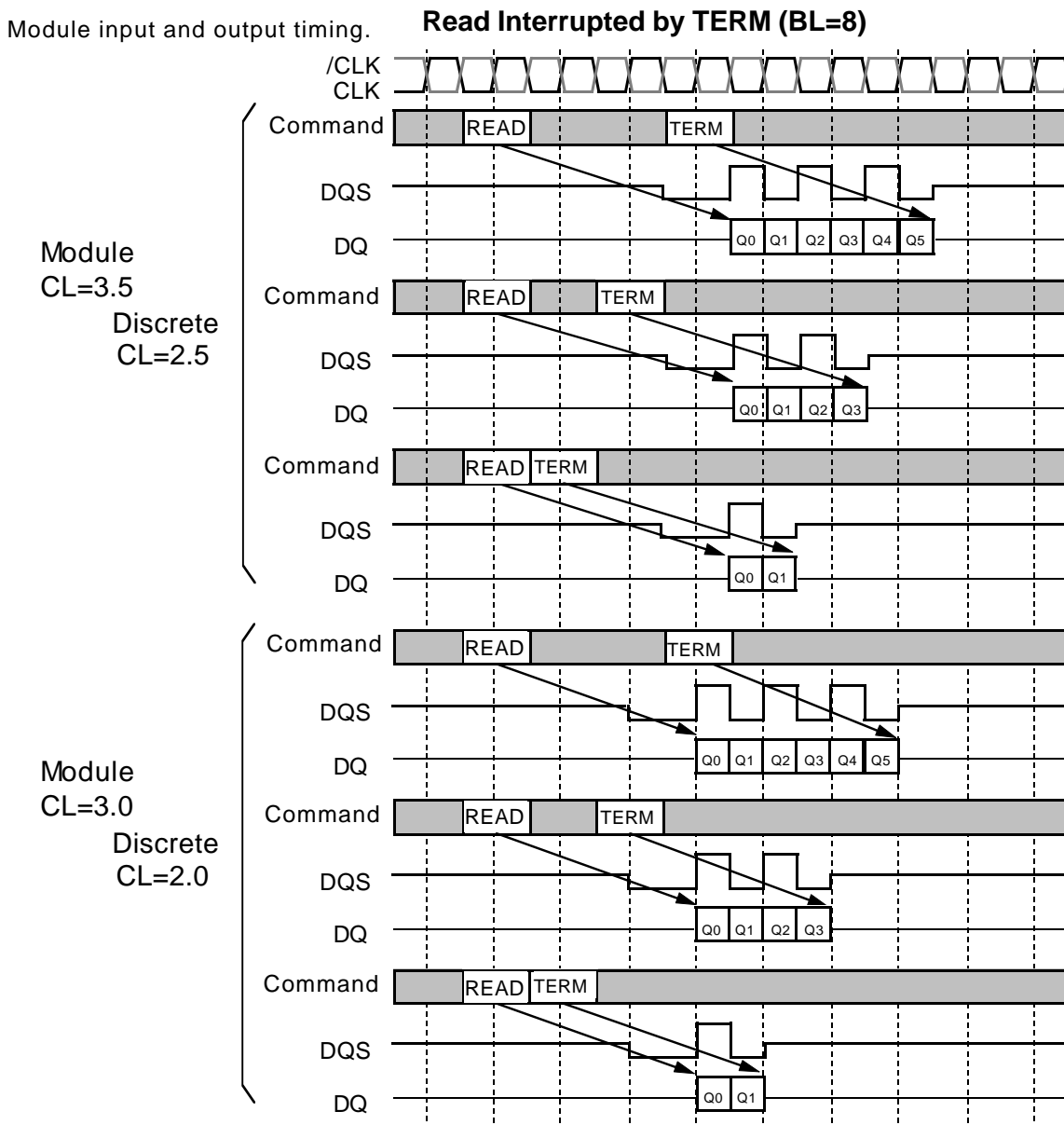

MH28D72AKTG-10,-75,-75A

9,663,676,416-BIT (134,217,728-WORD BY 72-BIT) Double Data Rate Synchronous DRAM Module

[Read Interrupted by Write with TERM]

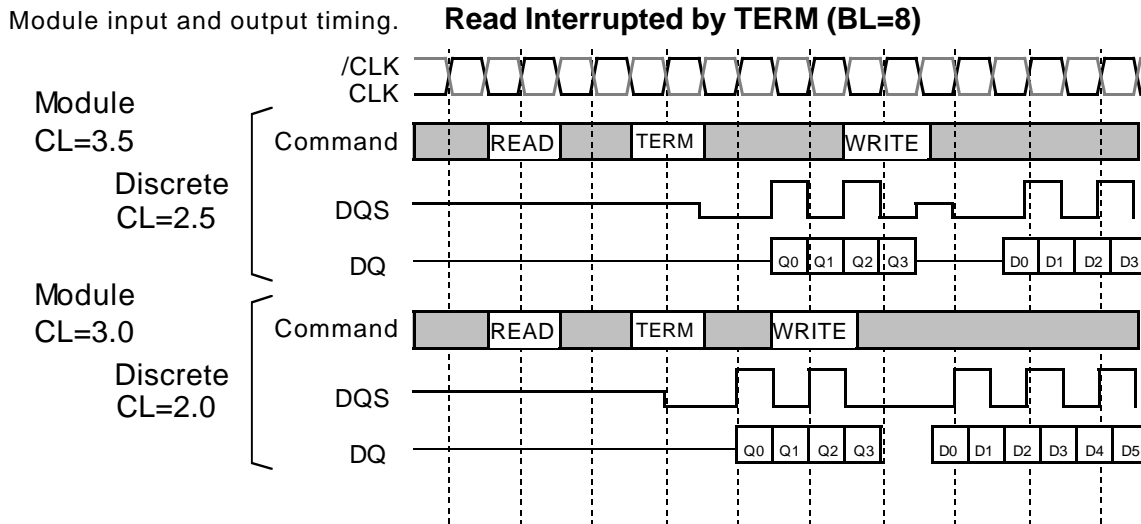

MH28D72AKTG-10,-75,-75A

9,663,676,416-BIT (134,217,728-WORD BY 72-BIT) Double Data Rate Synchronous DRAM Module

[Write interrupted by Write]

Burst write operation can be interrupted by write of any bank. Random column access is allowed. WRITE to WRITE interval is minimum 1 CLK.

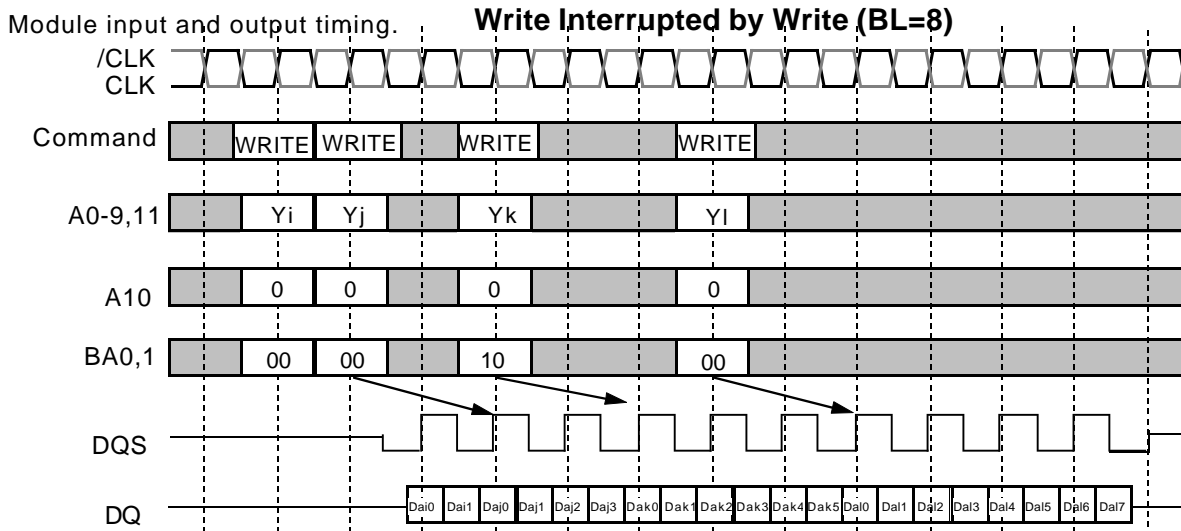

MH28D72AKTG-10,-75,-75A

9,663,676,416-BIT (134,217,728-WORD BY 72-BIT) Double Data Rate Synchronous DRAM Module

[Initialize and Mode Register sets]

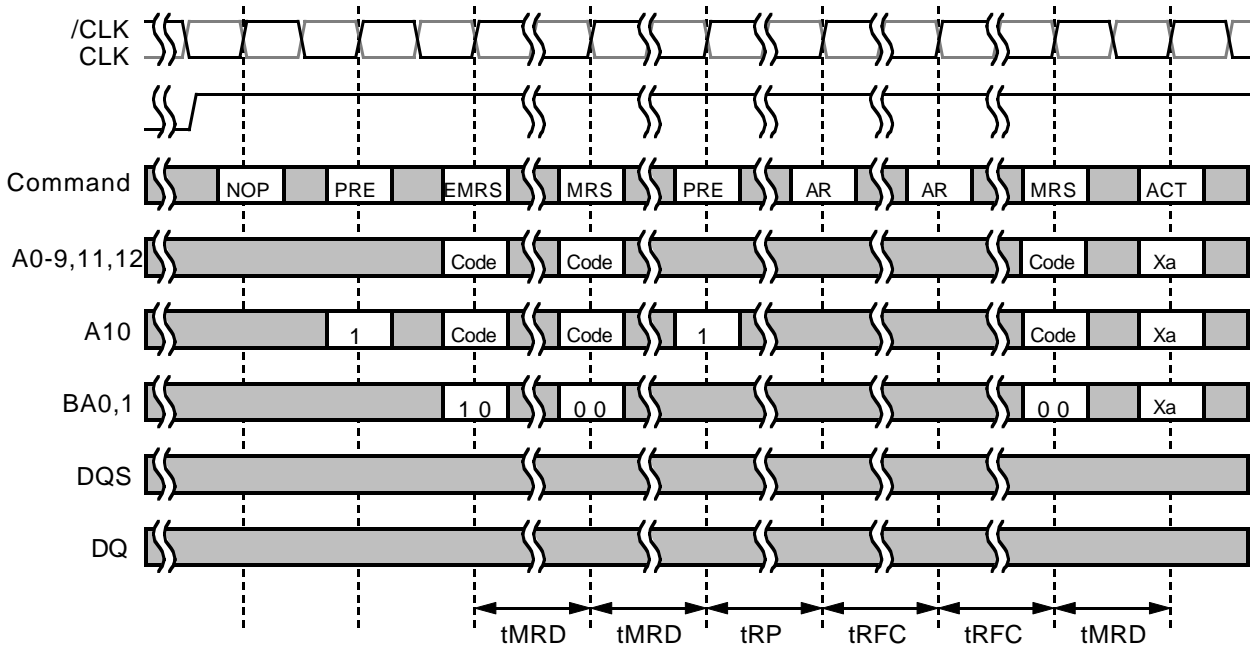

[AUTO REFRESH]

Single cycle of auto-refresh is initiated with a REFA(/CS=/RAS=/CAS=L,/WE=CKE=H) command. The refresh address is generated internally. 8192 REFA cycles within 64ms refresh 256Mbits memory cells. The auto-refresh is performed on 4 banks concurrently. Before performing an auto refresh, all banks must be in the idle state. Auto-refresh to auto-refresh interval is minimum t_{RFC} . Any command must not be supplied to the device before t_{RFC} from the REFA command.

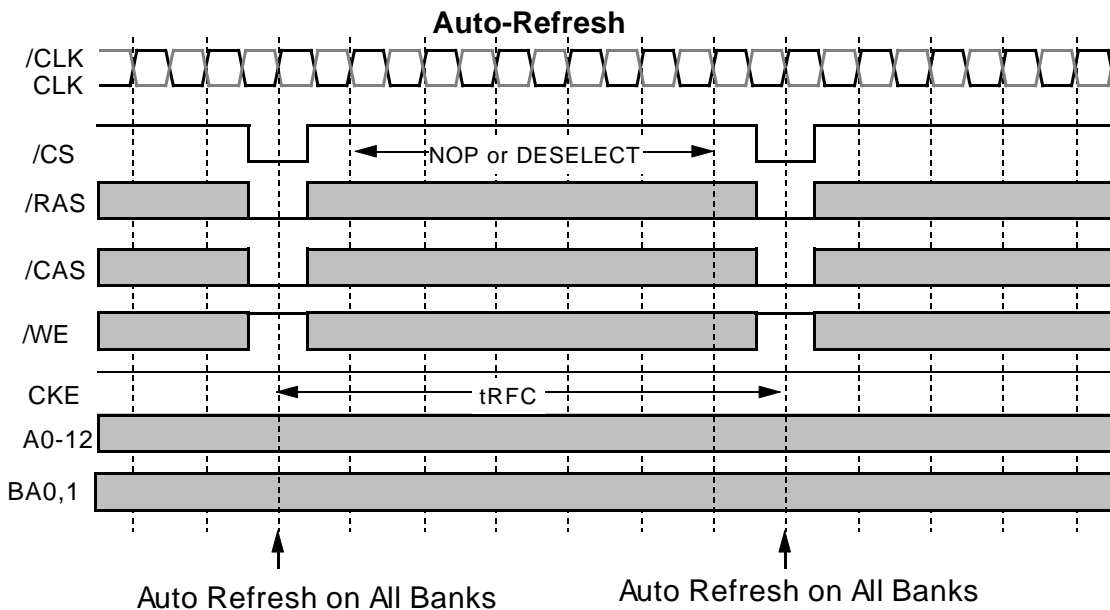

MH28D72AKTG-10,-75,-75A

9,663,676,416-BIT (134,217,728-WORD BY 72-BIT) Double Data Rate Synchronous DRAM Module

[SELF REFRESH]

Self -refresh mode is entered by issuing a REFS command (/CS=/RAS=/CAS=L,/WE=H,CKE=L). Once the self-refresh is initiated, it is maintained as long as CKE is kept low. During the self-refresh mode, CKE is asynchronous and the only enable input, all other inputs including CLK are disabled and ignored, so that power consumption due to synchronous inputs is saved. To exit the self-refresh, supplying stable CLK inputs, asserting DESEL or NOP command and then asserting CKE for longer than t_{XSNR} .

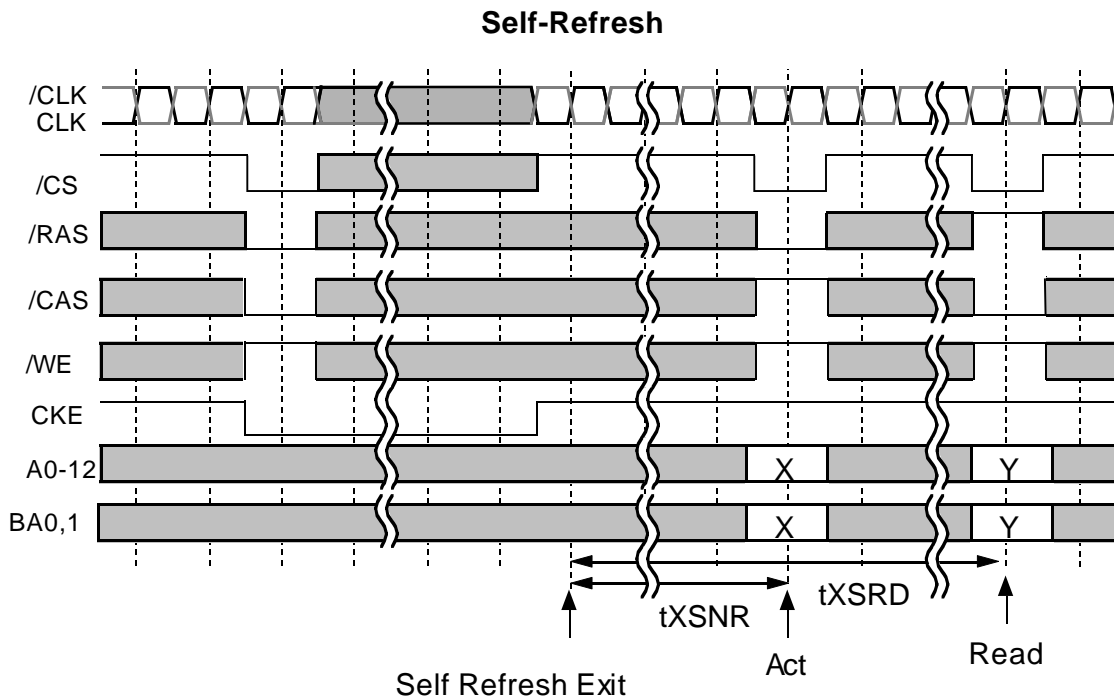

MH28D72AKTG-10,-75,-75A

9,663,676,416-BIT (134,217,728-WORD BY 72-BIT) Double Data Rate Synchronous DRAM Module

[Asynchronous SELF REFRESH]

Asynchronous Self-refresh mode is entered by CKE=L within 2 tCLK after issuing a REFA command (/CS=/RAS=/CAS=L,/WE=H). Once the self-refresh is initiated, it is maintained as long as CKE is kept low. During the self-refresh mode, CKE is asynchronous and the only enable input, all other inputs including CLK are disabled and ignored, so that power consumption due to synchronous inputs is saved. To exit the self-refresh, supplying stable CLK inputs, asserting DESEL or NOP command and then asserting CKE for longer than tXSNR/tXSRD.

Asynchronous Self-Refresh

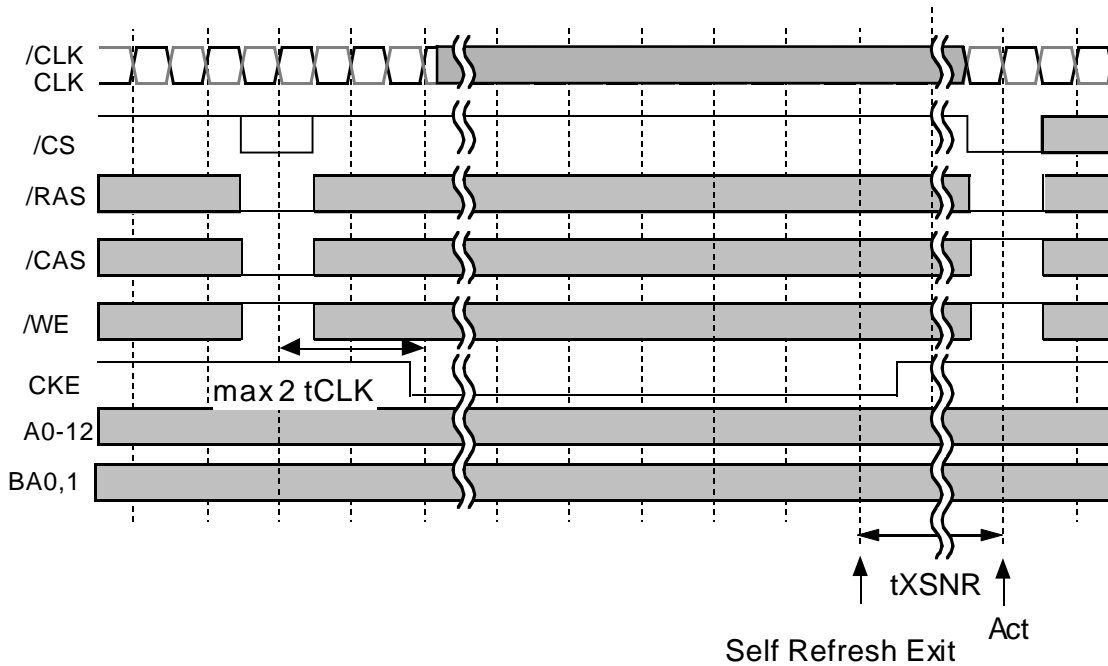

MH28D72AKTG-10,-75,-75A

9,663,676,416-BIT (134,217,728-WORD BY 72-BIT) Double Data Rate Synchronous DRAM Module

[Power DOWN]

The purpose of CLK suspend is power down. CKE is synchronous input except during the self-refresh mode. A command at cycle is ignored. From CKE=H to normal function, DLL recovery time is NOT required in the condition of the stable CLK operation during the power down mode.

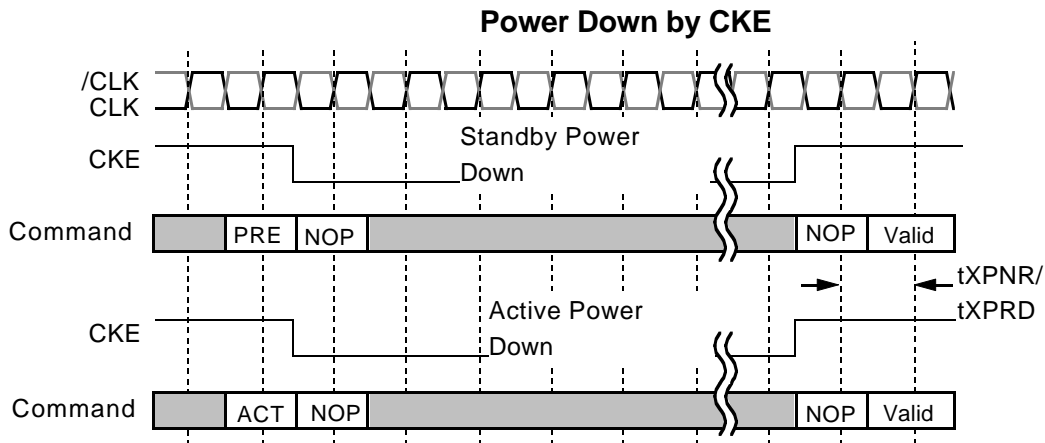

MH28D72AKTG-10,-75,-75A

9,663,676,416-BIT (134,217,728-WORD BY 72-BIT) Double Data Rate Synchronous DRAM Module

Serial Presence Detect Table I

Byte	Function described	SPD entry data	SPD DATA(hex)	
0	Number of Serial PD Bytes Written during Production	128	80	
1	Total # bytes of SPD memory device	256 Bytes	08	
2	Fundamental memory type	SDRAM DDR	07	
3	# Row Addresses on this assembly	13	0D	
4	# Column Addresses on this assembly	10	0B	
5	# Module Banks on this assembly	2BANK	02	
6	Data Width of this assembly...	x72	48	
7	... Data Width continuation	0	00	
8	Voltage interface standard of this assembly	SSTL2.5V	04	
9	SDRAM Cycletime at Max. Supported CAS Latency (CL). Cycle time for CL=2.5	-75A	7.5ns	75
		-75	7.5ns	75
		-10	8.0ns	80
10	SDRAM Access from Clock tAC for CL=2.5	-75A	+/-0.75ns	75
		-75	+/-0.75ns	75
		-10	+/-0.8 ns	80
11	DIMM Configuration type (Non-parity,Parity,ECC)	ECC	02	
12	Refresh Rate/Type	7.8uS/SR	82	
13	SDRAM width,Primary DRAM	x4	04	
14	Error Checking SDRAM data width	x4	04	
15	Minimum Clock Delay, Random Column Access	1 clock	01	
16	Burst Lengths Supported	2, 4, 8	0E	
17	Number of Device Banks	4bank	04	
18	CAS# Latency	2.0, 2.5	0C	
19	CS# Latency	0	01	
20	WE Latency	1	02	
21	SDRAM Module Attributes	Registered with PLL Differential Clock	26	
22	SDRAM Device Attributes:General	VDD +/- 0.2V	00	
23	SDRAM Cycle time(2nd highest CAS latency) Cycle time for CL=2	-75A	7.5ns	75
		-75	10ns	A0
		-10	10ns	A0
24	SDRAM Access form Clock(2nd highest CAS latency) tAC for CL=2	-75A	+/-0.75ns	75
		-75	+/-0.75ns	75
		-10	+/-0.8ns	80
25	SDRAM Cycle time(3rd highest CAS latency)	-75A	N/A	00
		-75	N/A	00
		-10	N/A	00
26	SDRAM Access form Clock(3rd highest CAS latency)	-75A	N/A	00
		-75	N/A	00
		-10	N/A	00
27	Minimum Row Precharge Time (tRP)	20ns	50	
28	Minimum Row Active to Row Active Delay (tRRD)	15ns	3C	
29	RAS to CAS Delay Minv (tRCD)	20ns	50	
30	Active to Precharge Min (tRAS)	-75A	45ns	2D
		-75	45ns	2D
		-10	50ns	32

MH28D72AKTG-10,-75,-75A

9,663,676,416-BIT (134,217,728-WORD BY 72-BIT) Double Data Rate Synchronous DRAM Module

Serial Presence Detect Table II

31	Density of each bank on module		512MByte	80
32	Command and Address signal input setup time	-75A	0.9nS	90
		-75	0.9nS	90
		-10	1.1nS	B0
33	Command and Address signal input hold time	-75A	0.9nS	90
		-75	0.9nS	90
		-10	1.1nS	B0
34	Data signal input setup time	-75A	0.5nS	50
		-75	0.5nS	50
		-10	0.6nS	60
35	Data signal input hold time	-75A	0.5nS	50
		-75	0.5nS	50
		-10	0.6nS	60
36-61	Superset Information (may be used in future)		option	00
62	SPD Revision		0	00
63	Checksum for bytes 0-62		Check sum for -75A	E6
			Check sum for -75	11
			Check sum for -10	97
64-71	Manufactures Jedec ID code per JEP-108E		MITSUBISHI	1C00000000000000
72	Manufacturing location		Manufacturing Location	xx
73-90	Manufactures Part Number		MH28D72AKTG-75A	4D483238443732414B54472D373541202020
			MH28D72AKTG-75	4D483238443732414B54472D373520202020
			MH28D72AKTG-10	4D483238443732414B54472D313020202020
91-92	Revision Code		PCB revision	rrrr
93-94	Manufacturing date		year/week code	yyww
95-98	Assembly Serial Number		serial number	ssssssss
99-127	Reserved		Undefined	00
128-255	Open for Customer Use		Undefined	00

MH28D72AKTG-10,-75,-75A

9,663,676,416-BIT (134,217,728-WORD BY 72-BIT) Double Data Rate Synchronous DRAM Module

EEPROM Components A.C. and D.C. Characteristics

Symbol	Parameter	Limits			Units
		Min.	Typ.	Max.	
V _{CC}	Supply Voltage	2.2		5.5	V
V _{SS}	Supply Voltage	0	0	0	V
V _{IH}	Input High Voltage	V _{CC} ×0.7		V _{CC} +0.5	V
V _{IL}	Input Low Voltage	-1		V _{CC} ×0.3	V
V _{OL}	Output Low Voltage			0.4	V

EEPROM A.C.Timing Parameters (T_a=0 to 70°C)

Symbol	Parameter	Limits		Units
		Min.	Max.	
f _{SCL}	SCL Clock Frequency		100	KHz
T _I	Noise Suppression Time Constant at SCL, SDA inputs		200	ns
T _{AA}	SCL Low to SDA Data Out Valid		3.5	us
T _{BUF}	Time the Bus Must Be Free before a New Transmission Can Start	4.7		us
T _{HD:STA}	Start Condition Hold Time	4.0		us
T _{LOW}	Clock Low Time	4.7		us
T _{HIGH}	Clock High Time	4.0		us
T _{SU:STA}	Start Condition Setup Time	4.7		us
T _{HD:DAT}	Data In Hold Time	0		us
T _{SU:DAT}	Data In Setup Time	250		ns
T _R	SDA and SCL Rise Time		1	us
T _F	SDA and SCL Fall Time		300	ns
T _{SU:STO}	Stop Condition Setup Time	4.0		us
T _{DH}	Data Out Hold Time	100		ns
T _{WR}	Write Cycle Time		10	ms

t_{WR} is the time from a valid stop condition of a write sequence to the end of the EEPROM internal erase/program cycle.

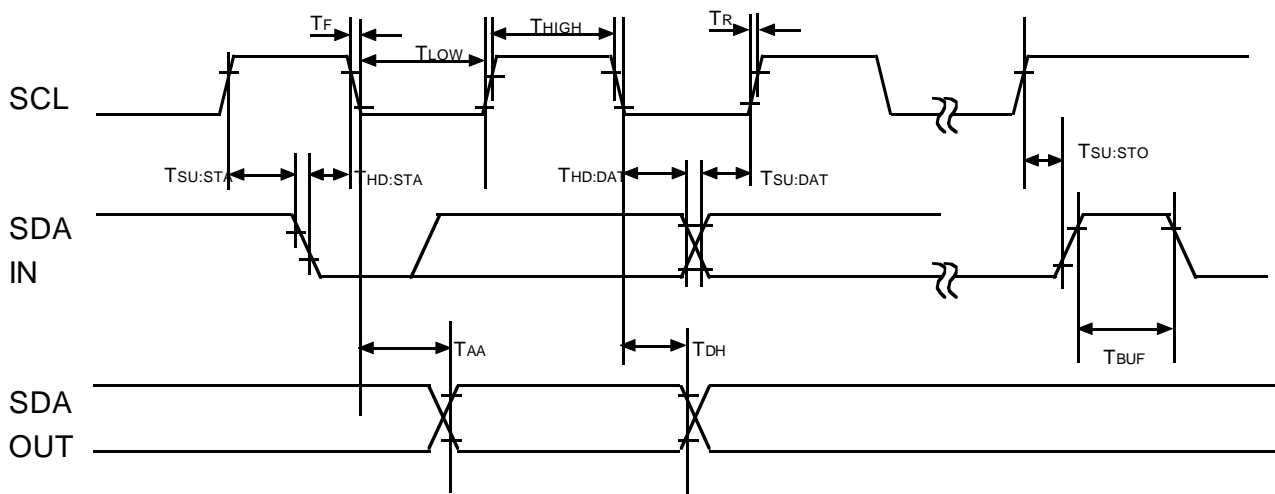

MH28D72AKTG-10,-75,-75A

9,663,676,416-BIT (134,217,728-WORD BY 72-BIT) Double Data Rate Synchronous DRAM Module

unit: millimeters

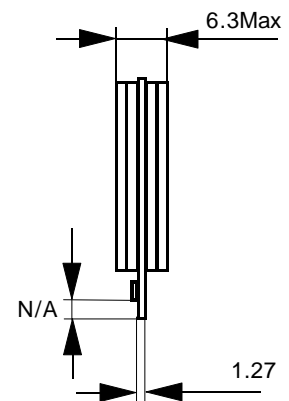
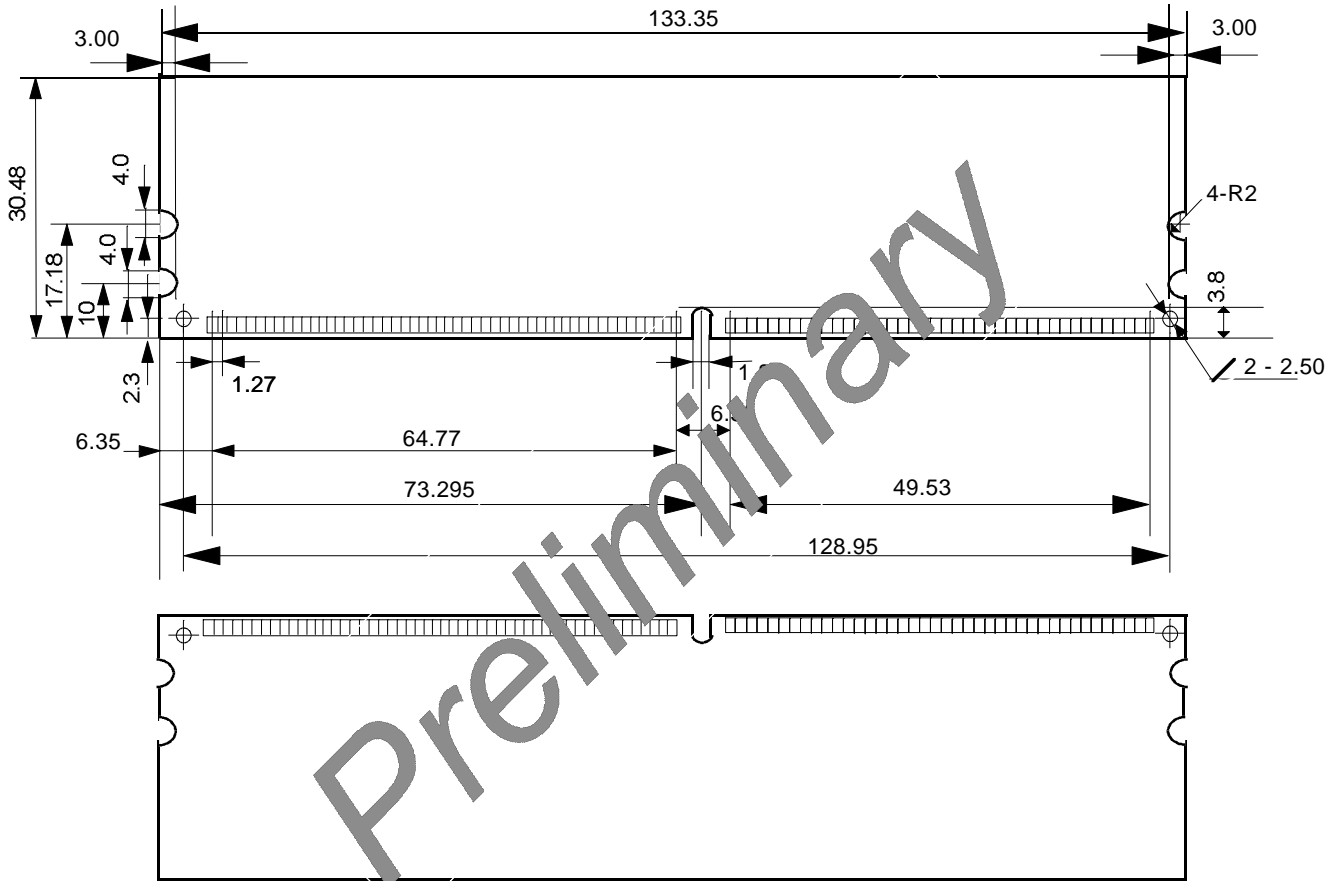

MH28D72AKTG-10,-75,-75A

9,663,676,416-BIT (134,217,728-WORD BY 72-BIT) Double Data Rate Synchronous DRAM Module

Keep safety first in your circuit designs!

Mitsubishi Electric Corporation puts the maximum effort into making semiconductor products better and more reliable, but there is always the possibility that trouble may occur with them. Trouble with semiconductors may lead to personal injury, fire or property damage. Remember to give due consideration to safety when making your circuit designs, with appropriate measures such as (i) placement of substitutive, auxiliary circuits, (ii) use of non-flammable material or (iii) prevention against any malfunction or mishap.

Notes regarding these materials

1. These materials are intended as a reference to assist our customers in the selection of the Mitsubishi semiconductor product best suited to the customer's application; they do not convey any license under any intellectual property rights, or any other rights, belonging to Mitsubishi Electric Corporation or a third party.
2. Mitsubishi Electric Corporation assumes no responsibility for any damage, or infringement of any third-party's rights, originating in the use of any product data, diagrams, charts, programs, algorithms, or circuit application examples contained in these materials.
3. All information contained in these materials, including product data, diagrams, charts, programs and algorithms represents information on products at the time of publication of these materials, and are subject to change by Mitsubishi Electric Corporation without notice due to product improvements or other reasons. It is therefore recommended that customers contact Mitsubishi Electric Corporation or an authorized Mitsubishi Semiconductor product distributor for the latest product information before purchasing a product listed herein. The information described here may contain technical inaccuracies or typographical errors. Mitsubishi Electric Corporation assumes no responsibility for any damage, liability, or other loss arising from these inaccuracies or errors. Please also pay attention to information published by Mitsubishi Electric Corporation by various means, including the Mitsubishi Semiconductor home page (<http://www.mitsubishichips.com>).
4. When using any or all of the information contained in these materials, including product data, diagrams, charts, programs and algorithms, please be sure to evaluate all information as a total system before making a final decision on the applicability of the information and products. Mitsubishi Electric Corporation assumes no responsibility for any damage, liability or other loss resulting from the information contained herein.
5. Mitsubishi Electric Corporation semiconductors are not designed or manufactured for use in a device or system that is used under circumstances in which human life is potentially at stake. Please contact Mitsubishi Electric Corporation or an authorized Mitsubishi Semiconductor product distributor when considering the use of a product contained herein for any specific purposes, such as apparatus or systems for transportation, vehicular, medical, aerospace, nuclear, or undersea repeater use.
6. The prior written approval of Mitsubishi Electric Corporation is necessary to reprint or reproduce in whole or in part these materials.
7. If these products or technologies are subject to the Japanese export control restrictions, they must be exported under a license from the Japanese government and cannot be imported into a country other than the approved destination. Any diversion or reexport contrary to the export control laws and regulations of Japan and/or the country of destination is prohibited.
8. Please contact Mitsubishi Electric Corporation or an authorized Mitsubishi Semiconductor product distributor for further details on these materials or the products contained therein.