

REVISION HISTORY			
REV	DESCRIPTION	DATE	APPROVED
-	DCN 36349	01/09	STW

# PRODUCT DATA DRAWING

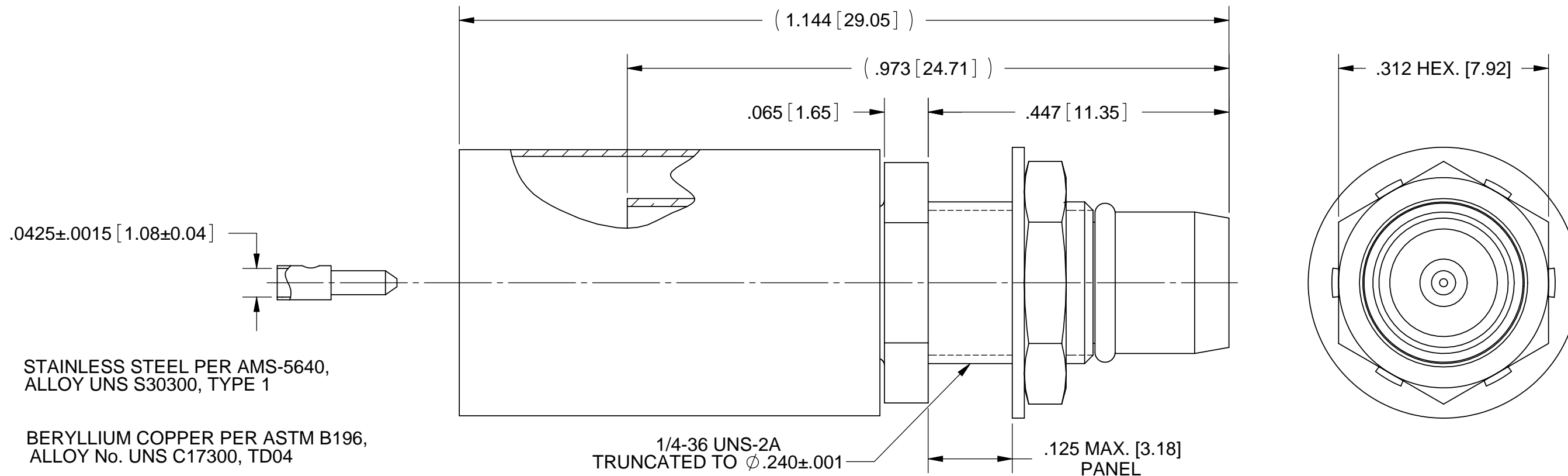

**MATERIAL:**

**BODY & HEX. NUT:** STAINLESS STEEL PER AMS-5640, ALLOY UNS S30300, TYPE 1

**CENTER CONTACT:** BERYLLIUM COPPER PER ASTM B196, ALLOY No. UNS C17300, TD04

**CABLE CONTACT:** BRASS PER ASTM B16, ALLOY UNS C36000

**INSULATOR:** PTFE PER ASTM D1710, TYPE I, GRADE 1, CLASS B

**O-RING:** FLUOROSILICONE RUBBER PER SAE-AMS-R-25988

**CRIMP RING:** COPPER PER ASTM B301, ALLOY UNSC18700

**LOCK WASHER:** STAINLESS STEEL PER ASTM-A-240, ALLOY UNS S30400, TYPE 304

**FINISH:**

**BODY, HEX NUT:** PASSIVATED PER AMS-2700, TYPE 2

**CONTACTS:** GOLD PER ASTM B488, TYPE II, CODE C, CLASS 1.27; OVER NICKEL PER AMS-QQ-N-290, CLASS 1, .00005" MIN.

**PERFORMANCE:**

**IMPEDANCE:** 50 OHMS  
**FREQ. RANGE:** DC TO 18.0 GHz  
**VSWR:** 1.15 + .01 DC TO 18.0 GHz OR APPROXIMATELY 80% OF UPPER CUTOFF FREQ. OF THE CABLE, WHICHEVER IS LOWER.  
**INSUL. RES.:** 5000 MEGOHMS MIN.  
**DWV:** 1000 VRMS

MATERIAL: SEE NOTES	DIMENSIONS ARE IN INCHES TOLERANCES: FRACTIONAL: ±1/64 ANGULAR: X° ±1'0" X°X' ±15'	UNLESS OTHERWISE SPECIFIED 1) ALL DIMENSIONS ARE IN INCHES (MILLIMETERS) 2) ALL DIMENSIONS ARE AFTER PLATING. 3) BREAK CORNERS & EDGES .005 R. MAX. 4) CHAM. 1ST & LAST THREADS. 5) SURFACE ROUGHNESS 63-MIL-STD-10. 6) DIA.'S ON COMMON CENTERS TO BE CONCENTRIC WITHIN .005 T.I.R. 7) REMOVE ALL BURRS	<b>SV Microwave, Inc.</b> 2400 Centrepark West Drive, Suite 100 West Palm Beach, FL 33409
FINISH: SEE NOTES	DECIMAL: .X ±.030 .XX ±.010 .XXX ±.005	INTERPRET DIMENSIONS AND TOLERANCES PER ASME Y14.5M - 1994	TITLE: BMA PLUG, JAM NUT MNT. FOR RG400 CABLE
SURFACE AREA: N/A	THIRD ANGLE PROJECTION	DRAWN: HLP 01/09/08 CHECKED: STW 01/09/09 APPROVED: STW 01/09/09	SIZE: B CAGE CODE: 95077 DWG. NO.: SF1708-6301
<p><b>PROPRIETARY</b></p> <p>THE INFORMATION CONTAINED IN THIS DRAWING IS THE SOLE PROPERTY OF SV MICROWAVE, INC. ANY REPRODUCTION IN PART OR AS A WHOLE WITHOUT THE WRITTEN PERMISSION OF SV MICROWAVE, INC IS PROHIBITED.</p>			SCALE: 6:1 SHEET 1 OF 1