



Technical  
Publication  
**TR395C/NQ**  
Issue 2  
January 1985

### High Frequency Inverter Grade Capsule Thyristor Type R395C/NQ

distributed amplified gate for high di/dt and low switching losses

**1050 amperes average: up to 2100 volts  $V_{DRM}$**

**Ratings (Maximum values at 125°C Tj unless stated otherwise)**

RATING	CONDITIONS	SYMBOL	
Average on-state current	Half sine wave { 55°C heatsink temperature (double side cooled) 85°C heatsink temperature (single side cooled)	$I_{T(AV)}$	1050 A 393 A
R.M.S. on-state current	25°C heatsink temperature, double side cooled	$I_T(RMS)$	2140 A
Continuous on-state current	25°C heatsink temperature, double side cooled	$I_T$	1720 A
Peak one-cycle surge (non-repetitive) on state current	10ms duration, 60% $V_{RRM}$ re-applied	$I_{TSM(1)}$	15500 A
	10ms duration, $V_R \leq 10$ volts	$I_{TSM(2)}$	17000 A
Maximum permissible surge energy	10ms duration, $V_R \leq 10$ volts	$I^2t(2)$	1450000 A <sup>2</sup> s
	3ms duration, $V_R \leq 10$ volts	$I^2t$	1080000 A <sup>2</sup> s
Peak forward gate current	Anode positive with respect to cathode	$I_{FGM}$	36 A
Peak forward gate voltage	Anode positive with respect to cathode	$V_{FGM}$	16 V
Peak reverse gate voltage		$V_{RGM}$	5 V
Average gate power		$P_G$	2 W
Peak gate power	100µs. pulse width	$P_{GM}$	120 W
Rate of rise of off-state voltage	To 80% $V_{DRM}$ gate open-circuit	$dv/dt$	*200V/µs
Rate of rise of on-state current (repetitive)	{ Gate drive 20 volts, 20 ohms with $t_r \leq 1\mu s.$ Anode voltage $\leq 80\% V_{DRM}$ }	$di/dt(1)$	1000A/µs
Rate of rise of on-state current (non-repetitive)		$di/dt(2)$	1500A/µs
Operating temperature range		$T_{hs}$	-40 + 125°C
Storage temperature range		$T_{stg}$	-40 + 150°C

### Characteristics (Maximum values at 125°C Tj unless stated otherwise)

CHARACTERISTIC	CONDITIONS	SYMBOL	
Peak on-state voltage	At 2000 A, $I_{TM}$	$V_{TM}$	1.9 V
Forward conduction threshold voltage		$V_O$	1.3 V
Forward conduction slope resistance		$r$	0.3 mΩ
Repetitive peak off-state current	At $V_{DRM}$	$I_{DRM}$	100 mA
Repetitive peak reverse current	At $V_{RRM}$	$I_{RRM}$	100 mA
Maximum gate current required to fire all devices	{ At 25°C, $V_A = 10$ V, $I_A = 2$ A }	$I_{GT}$	300 mA
Maximum gate voltage required to fire all devices		$V_{GT}$	3 V
Maximum holding current		$I_H$	1 A
Maximum gate voltage which will not trigger any device		$V_{GD}$	0.25 V
Stored charge	$I_{TM} = 1000A$ , $dir/dt = 60A/\mu s$ $V_{RM} = 50V$ , 50% chord value	$Q_{rr}$	420 µC
Circuit commutated turn-off time available down to	$I_{TM} = 1000A$ $dir/dt = 60A/\mu s$ , $V_{RM} = 50V$ { 200V/µs to 80% $V_{DRM}$ 20V/µs to 80% $V_{DRM}$	$t_q$ $t_q$ typical	65-75 µs 60-70 µs
Thermal resistance, junction to heat sink, for a device with a maximum forward volt drop characteristic	Double side cooled Single side cooled	$R_{th(j-hs)}$	0.032°C/W 0.064°C/W

VOLTAGE CODE		H16	H18	H20	H21				
Repetitive peak voltages	$V_{DRM}$	1600	1800	2000	2100				
Non-repetitive peak off-state voltage	$V_{DSM}$								
Repetitive peak reverse blocking voltage	$V_{RRM}$	60% $V_{DRM}$							

### Ordering Information (Please quote device code as explained below)

R	3	9	5	C	•	•	•	•	•	0	/NQ
Fixed type code	Voltage Code (see ratings)				dv/dt code to 80% $V_{DRM}$ C = 20V/µs E = 100V/µs D = 50V/µs F = 200V/µs		Turn-off time E = 75 µs 2G = 70 µs W = 65 µs 2H = 60 µs				

Typical code: R395CH16CW0/NQ = 1600  $V_{DRM}$   $dv/dt$  20 V/µs to 80%  $V_{DRM}$  65 µs turn-off

\*Other values of  $dv/dt$  up to 1000 V/µs. and turn-off time may be available.

## 1. INTRODUCTION

The R395/NQ thyristor is particularly suited to inverter and chopper applications especially those incorporating reverse parallel diodes. A 60% reverse voltage capability is maintained in the R395/NQ to withstand voltages induced within the thyristor-diode loop inductance at commutation.

## 2. NOTES ON THE RATINGS

### (a) Rate of rise of on-state current

The maximum un-primed rate of rise of on-state current must not exceed 1500 A/ $\mu$ s at any time during turn-on on a non-repetitive basis. For repetitive performance the on-state rate of rise of current must not exceed 1000 A/ $\mu$ s at any time during turn-on. Note that these values of current rate of rise apply to the circuit external to the device and its specified snubber network and device current rates of rise will be higher.

### (b) Square wave ratings

These ratings are given for leading edge linear rates of rise of forward current of 100 and 500 A/ $\mu$ s.

### (c) Duty Cycle Lines

The 100% duty cycle line appears on all these ratings. These frequency ratings are presented in the form that all duty cycles may be represented by straight parallel lines.

### (d) Maximum operating Frequency

The maximum operating frequency,  $f_{max}$ , is set by the time required for the thyristor to turn off ( $t_q$ ) and for the off-state voltage to reach full value ( $t_v$ ), i.e.

$$f_{max} = \frac{1}{t_{pulse} + t_q + t_v}$$

### (e) Energy per pulse characteristics

These curves enable rapid estimation of device dissipation to be obtained for conditions not covered by the frequency ratings.

Let  $E_p$  be the Energy per pulse for a given current and pulse width, in joules.

Then  $W_{AV} = E_p \times f$ .

## 3. REVERSE RECOVERY LOSS

On account of the number of circuit variables affecting reverse recovery voltage, no allowance for reverse recovery loss has been made in these ratings. The following procedure is recommended for use where it is necessary to include reverse recovery loss.

### (a) Determination by Measurement

From waveforms of recovery current obtained from a high frequency shunt (see Note 1) and reverse voltage present during recovery, an instantaneous reverse recovery loss waveform must be constructed. Let the area under this waveform be  $A$  joules per pulse. A new heat sink temperature can then be evaluated from:

$$T_{SINK} (new) = T_{SINK} (original) - A \left( \frac{r_t \cdot 10^6}{t} + R_{th} \times f \right)$$

where  $r_t = 4.11 \times 10^{-5} \sqrt{t}$ .

$t$  = duration of reverse recovery loss per pulse in microseconds

$A$  = Area under reverse loss waveform per pulse in joules (W.S.)

$f$  = rated frequency at the original heat sink temperature

The total dissipation is now given by

$$W_{(TOT)} = W_{(original)} + A \times f$$

### (b) Design Method

In circumstances where it is not possible to measure voltage and current conditions, or for design purposes, the additional losses may be estimated from figure 7. A typical R-C snubber network is connected across the thyristor to control the transient reverse voltage waveform.

Let  $E$  be the value of energy per reverse cycle in joules (figure 7).

Let  $f$  be the operating frequency in Hz

then  $T_{SINK} new = T_{SINK} original - ER_{th} \times f$

where  $T_{SINK} new$  is the required maximum heat sink temperature

and  $T_{SINK} original$  is the heat sink temperature given with the frequency ratings.

## 4. GATE DRIVE

The recommended gate drive is 20 V, 20 ohms with a short-circuit current rise time of not more than 1  $\mu$ s. This gate drive must be applied when using the full di/dt capability of the device.

## 5. THE DV/DT SUPPRESSION NETWORK

The effect of a conventional resistor-capacitor snubber of 0.25  $\mu$ F 5 ohms has been included in these ratings and all rating di/dt values apply to the circuit external to the thyristor and its suppression network.

## 6. NOTE 1

### REVERSE RECOVERY LOSS BY MEASUREMENT

This thyristor has a low reverse recovered charge and peak reverse recovery current. When measuring the charge care must be taken to ensure that:

- a.c. coupled devices such as current transformers are not affected by prior passage of high amplitude forward current.
- The measuring oscilloscope has adequate dynamic range — typically 100 screen heights — to cope with the initial forward current without overload.

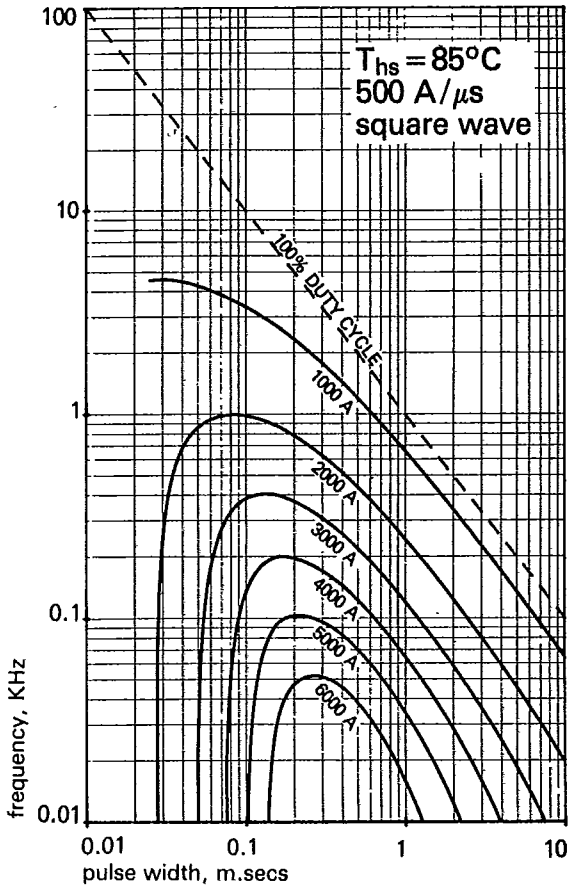


Figure 1 Frequency v. pulse width

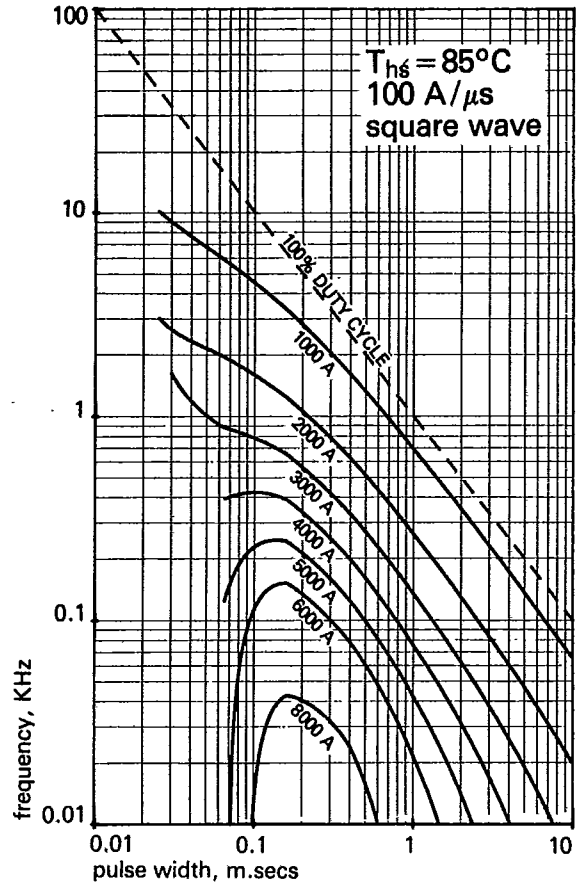


Figure 2 Frequency v. pulse width

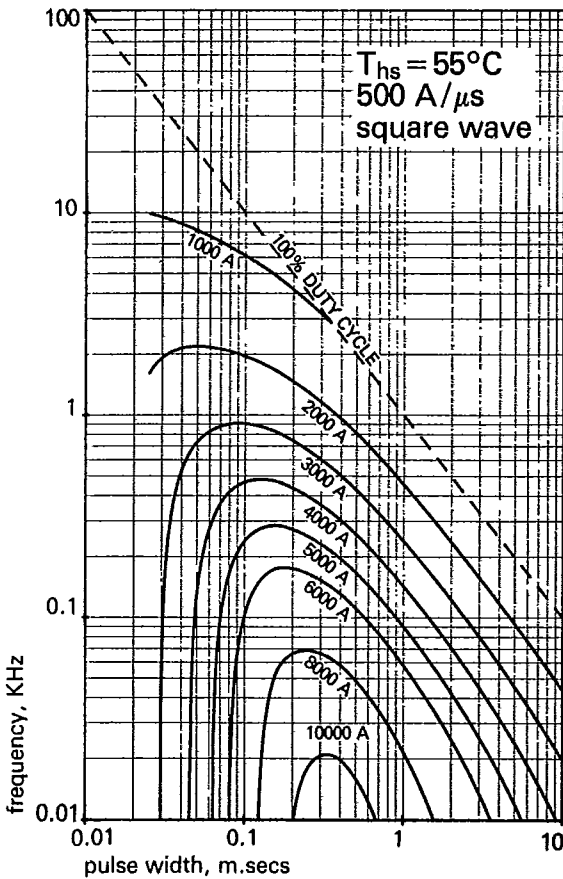


Figure 3 Frequency v. pulse width

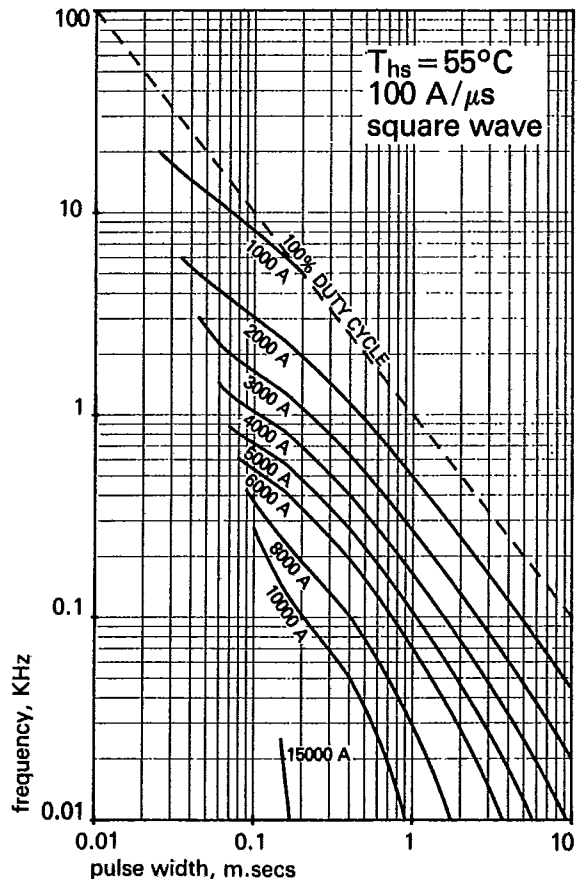


Figure 4 Frequency v. pulse width

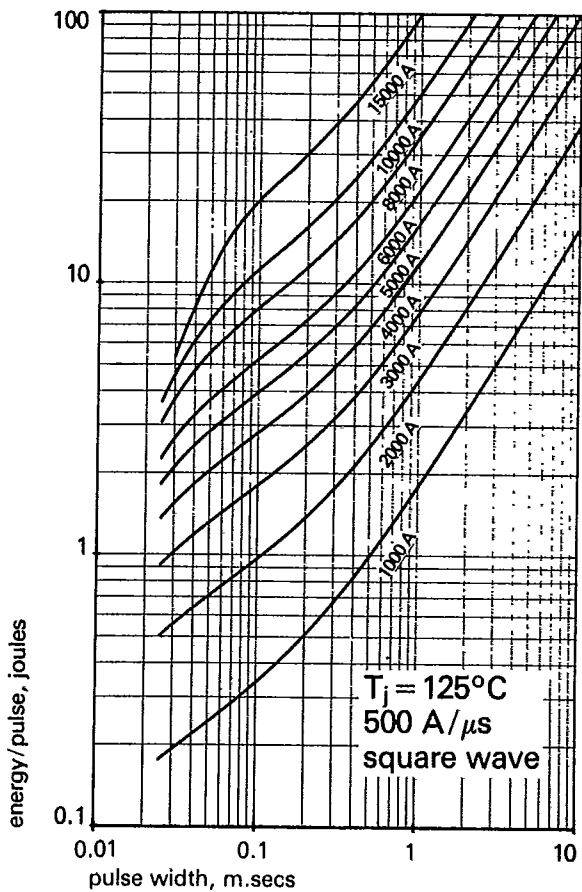


Figure 5 Energy/pulse v. pulse width

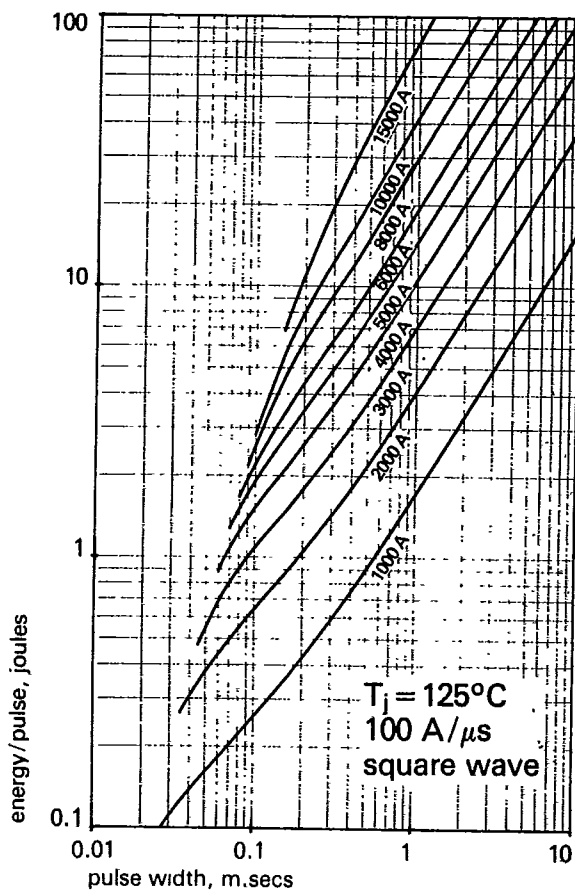


Figure 6 Energy/pulse v. pulse width

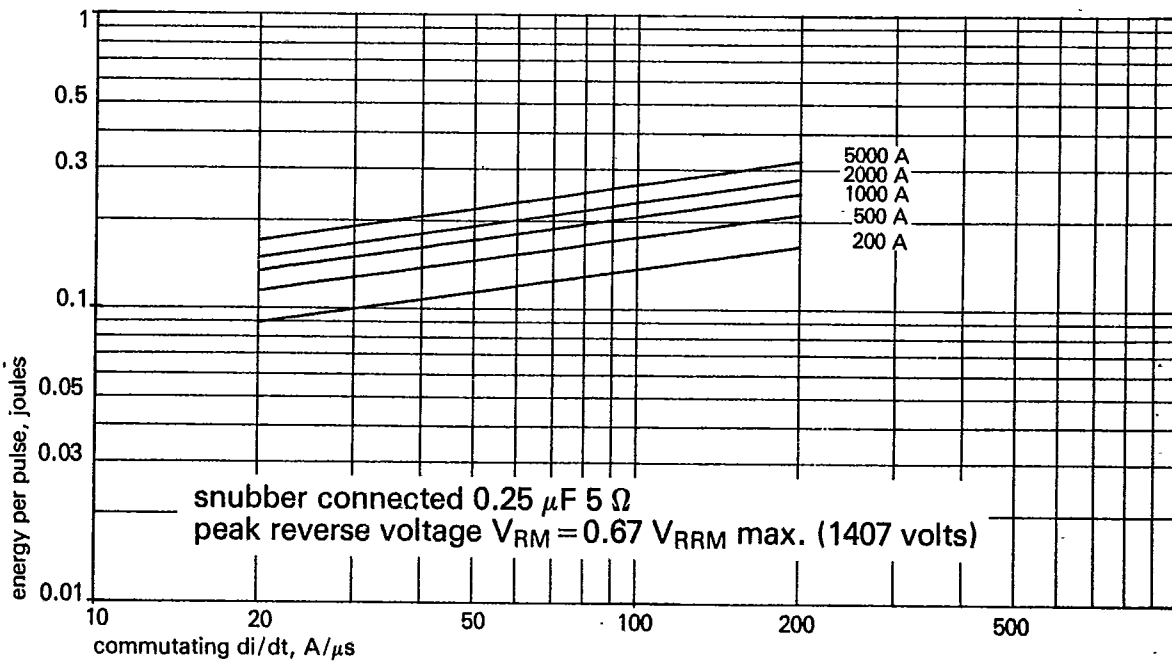


Figure 7 Max. reverse recovery energy loss per pulse at  $125^\circ\text{C}$  junction temperature and  $V_{RM} = 1407 \text{ volts}$

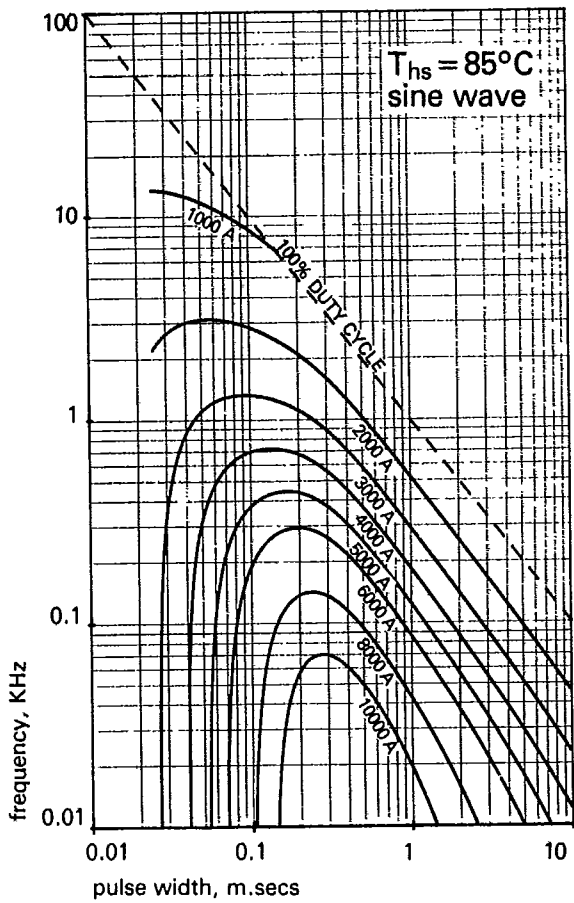


Figure 8 Frequency v. pulse width

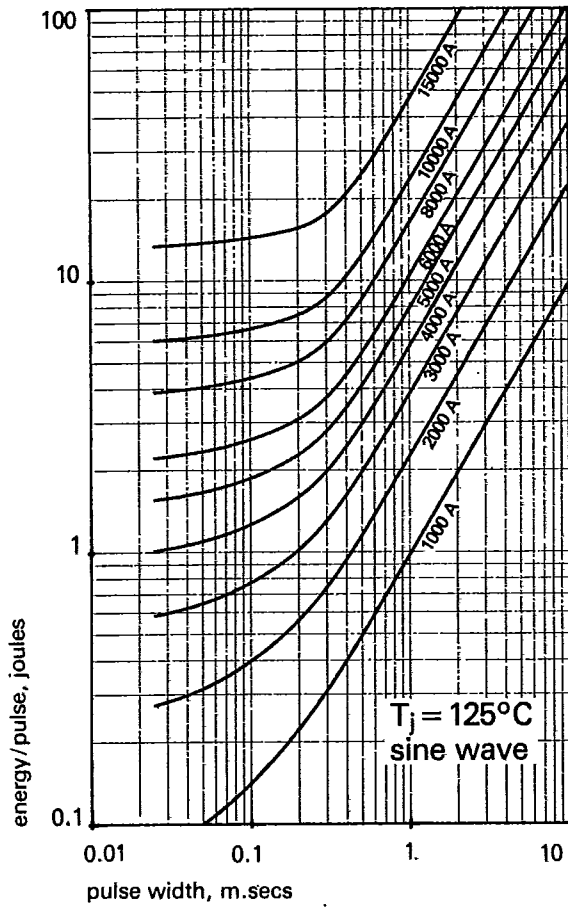


Figure 9 Energy/pulse v. pulse width

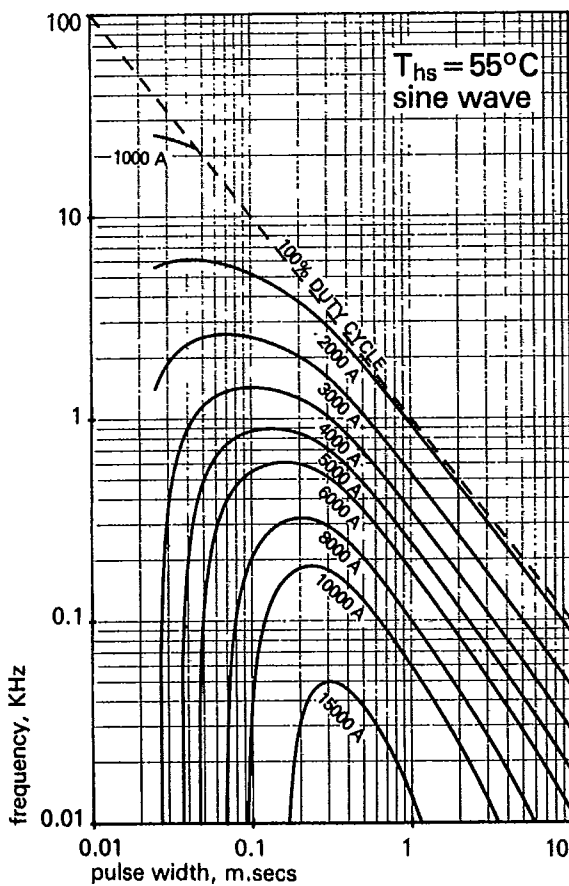


Figure 10 Frequency v. pulse width

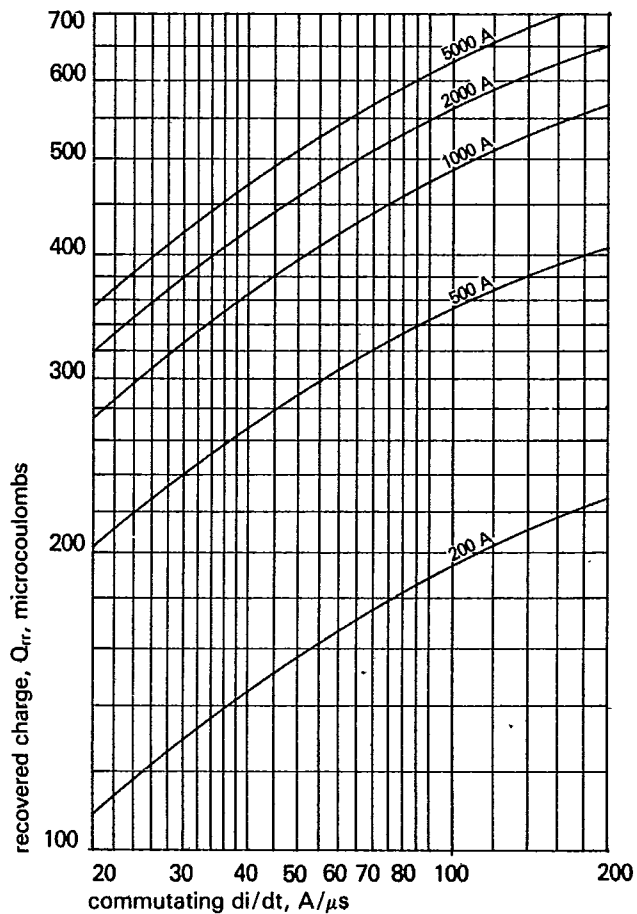
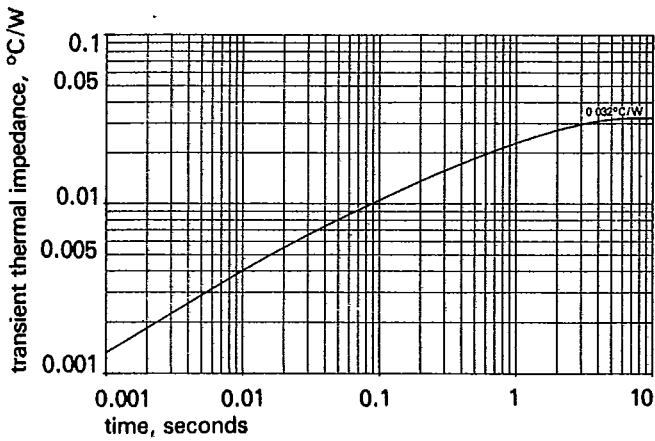
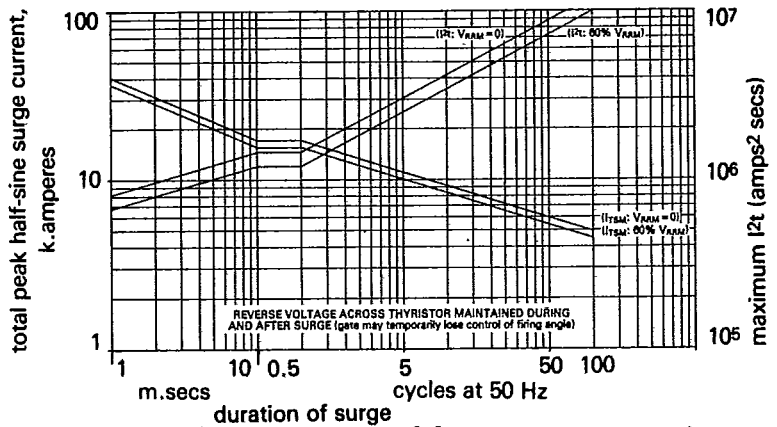


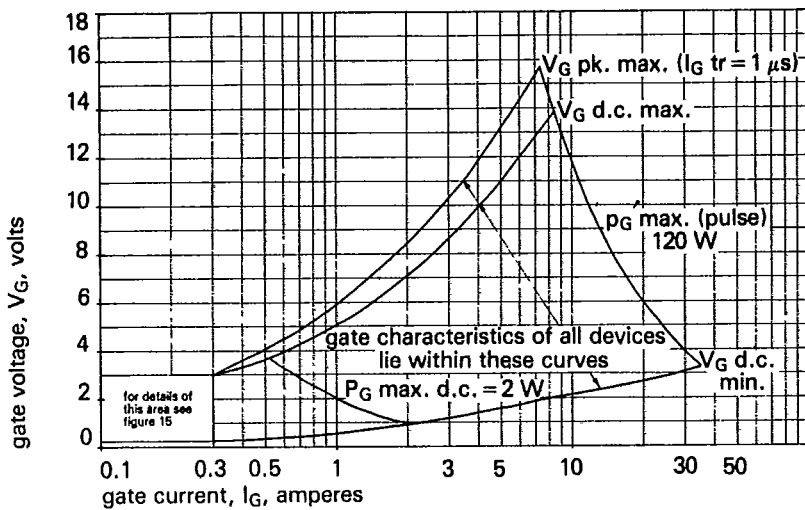
Figure 11 Maximum recovered charge at  $125^{\circ}\text{C}$  junction temperature



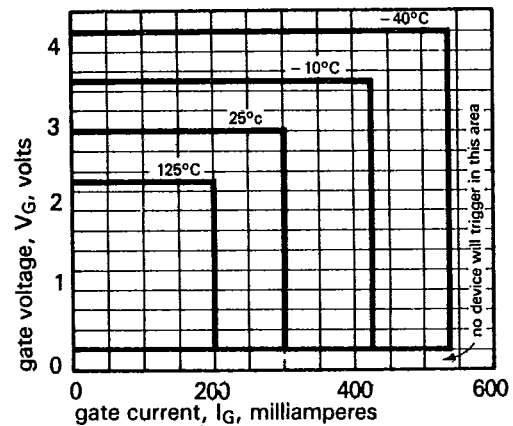
**Figure 12** Junction to heatsink transient thermal impedance



**Figure 13** Max. non-repetitive surge current at initial junction temperature 125°C  
Note: This rating must not be interpreted as an intermittent rating

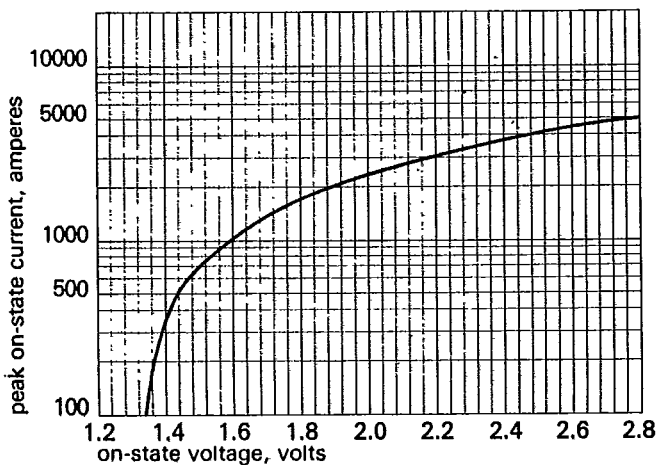


**Figure 14** Gate characteristics at 25°C junction temperature



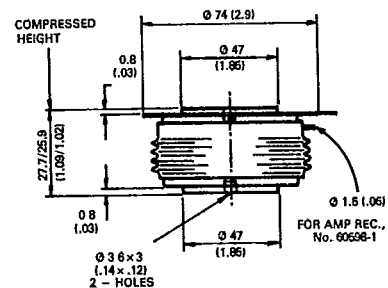
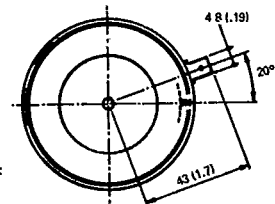
**Figure 15** Gate triggering characteristics.

Trigger points of all thyristors lie within the areas shown. Gate drive load line must lie outside appropriate  $I_G/V_G$  rectangle



**Figure 16** Limit on-state current at 125°C

dimensions in mm (inches)  
Mounting force: 1900-2600 kgf  
Weight: 510 grams



TO - 200AC

In the interest of product improvement, Westcode reserves the right to change specifications at any time without notice.

**WESTCODE SEMICONDUCTORS LTD**

P.O. Box 57 Chippenham Wiltshire SN15 1JL England  
Telephone Chippenham (0249) 654141 Telex 44751