

# SN54HC283, SN74HC283 4-BIT BINARY FULL ADDERS WITH FAST CARRY

D2804, MARCH 1984—REVISED SEPTEMBER 1987

- Full-Carry Look-Ahead Across the Four Bits
- Systems Achieve Partial Look-Ahead Performance with the Economy of Ripple Carry
- Supply Voltage and Ground on Corner Pins to Simplify P-C Board Layout
- Package Options Include Plastic "Small Outline" Packages, Ceramic Chip Carriers, and Standard Plastic and Ceramic 300-mil DIPs
- Dependable Texas Instruments Quality and Reliability

## description

These improved full adders perform the addition of two 4-bit binary words. The sum ( $\Sigma$ ) outputs are provided for each bit, and the resultant carry (C4) is obtained from the fourth bit.

These adders feature full internal look-ahead across all four bits generating the carry term. This capability provides the system designer with partial look-ahead performance at the economy and reduced package count of a ripple-carry implementation.

The adder logic, including the carry, is implemented in its true form. End around carry can be accomplished without the need for logic or level inversion.

The SN54HC283 is characterized for operation over the full military temperature range of  $-55^{\circ}\text{C}$  to  $125^{\circ}\text{C}$ . The SN74HC283 is characterized for operation from  $-40^{\circ}\text{C}$  to  $85^{\circ}\text{C}$ .

SN54HC283 . . . J PACKAGE  
SN74HC283 . . . D OR N PACKAGE

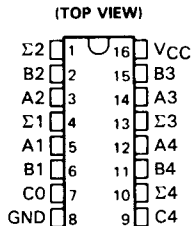

SN54HC283 . . . FK PACKAGE  
(TOP VIEW)

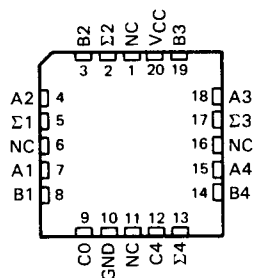

NC—No internal connection

2

HCMOS Devices

**SN54HC283, SN74HC283**  
**4-BIT BINARY FULL ADDERS WITH FAST CARRY**

2

HC MOS Devices

FUNCTION TABLE

INPUT				OUTPUT						
				WHEN C0 = L			WHEN C0 = H			
A1	B1	A2	B2	Σ1	Σ2	C2	Σ1	Σ2	C2	
A3	B3	A4	B4	Σ3	Σ4	C4	Σ3	Σ4	C4	
L	L	L	L	L	L	L	H	L	L	
H	L	L	L	L	H	L	L	H	L	
L	H	L	L	L	H	L	L	H	L	
H	H	L	L	L	L	H	H	H	L	
L	L	H	L	L	L	L	H	H	L	
H	L	H	L	L	H	L	L	L	H	
L	H	H	L	L	H	H	L	L	H	
H	H	H	L	L	L	L	H	H	L	
L	L	L	H	L	L	H	L	H	L	
H	L	L	H	L	H	L	L	L	H	
L	H	L	H	L	H	L	L	L	H	
H	H	L	H	L	L	H	H	L	H	
L	L	H	H	L	L	H	H	L	H	
H	L	H	H	L	H	L	L	H	H	
L	H	H	H	L	L	H	L	H	H	
H	H	H	H	L	H	H	H	H	H	

H = high level, L = low level

NOTE: Input conditions at A1, B1, A2, B2, and C0 are used to determine outputs Σ1 and Σ2 and the value of the internal carry C2. The values at C2, A3, B3, A4, and B4 are then used to determine outputs Σ3, Σ4, and C4.

logic symbol†

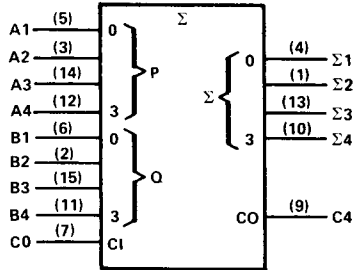

† This symbol is in accordance with ANSI/IEEE Std 91-1984 and IEC Publication 617-12.

Pin numbers shown are for D, J, and N packages.

SN54HC283, SN74HC283  
4-BIT BINARY FULL ADDERS WITH FAST CARRY

logic diagram (positive logic)

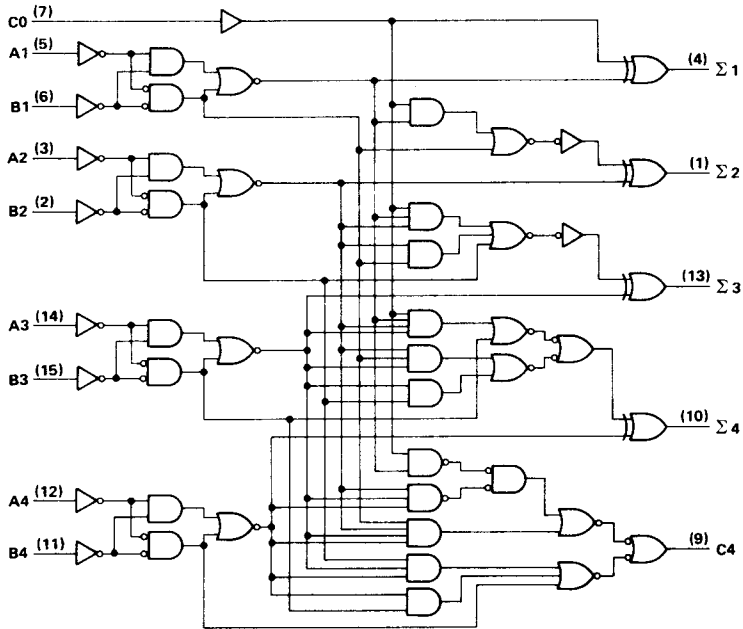

Pin numbers shown are for D, J, and N packages.

2

HCMOS Devices

# SN54HC283, SN74HC283

## 4-BIT BINARY FULL ADDERS WITH FAST CARRY

### absolute maximum ratings over operating free-air temperature range†

Supply voltage, $V_{CC}$ .....	-0.5 V to 7 V
Input clamp current, $I_{IK}$ ( $V_I < 0$ or $V_I > V_{CC}$ ) .....	$\pm 20$ mA
Output clamp current, $I_{OK}$ ( $V_O < 0$ or $V_O > V_{CC}$ ) .....	$\pm 20$ mA
Continuous output current, $I_O$ ( $V_O = 0$ to $V_{CC}$ ) .....	$\pm 25$ mA
Continuous current through $V_{CC}$ or GND pins .....	$\pm 50$ mA
Lead temperature 1,6 mm (1/16 in) from case for 60 s: FK or J package .....	300°C
Lead temperature 1,6 mm (1/16 in) from case for 10 s: D or N package .....	260°C
Storage temperature range .....	-65°C to 150°C

†Stresses beyond those listed under "absolute maximum ratings" may cause permanent damage to the device. These are stress ratings only, and functional operation of the device at these or any other conditions beyond those indicated under "recommended operating conditions" is not implied. Exposure to absolute-maximum-rated conditions for extended periods may affect device reliability.

### recommended operating conditions

		SN54HC283			SN74HC283			UNIT
		MIN	NOM	MAX	MIN	NOM	MAX	
$V_{CC}$	Supply voltage	2	5	6	2	5	6	V
$V_{IH}$	High-level input voltage	$V_{CC} = 2$ V		1.5	1.5		V	
		$V_{CC} = 4.5$ V		3.15	3.15			
		$V_{CC} = 6$ V		4.2	4.2			
$V_{IL}$	Low-level input voltage	$V_{CC} = 2$ V		0	0.3		V	
		$V_{CC} = 4.5$ V		0	0.9			
		$V_{CC} = 6$ V		0	1.2			
$V_I$	Input voltage	0		$V_{CC}$	0		$V_{CC}$	V
$V_O$	Output voltage	0		$V_{CC}$	0		$V_{CC}$	V
$t_t$	Input transition (rise and fall) times	$V_{CC} = 2$ V		0	1000		ns	
		$V_{CC} = 4.5$ V		0	500			
		$V_{CC} = 6$ V		0	400			
$T_A$	Operating free-air temperature	-55		125	-40		85	°C

### electrical characteristics over recommended operating free-air temperature range (unless otherwise noted)

PARAMETER	TEST CONDITIONS	$V_{CC}$	$T_A = 25^\circ\text{C}$			SN54HC283			SN74HC283			UNIT
			MIN	TYP	MAX	MIN	TYP	MAX	MIN	TYP	MAX	
$V_{OH}$	$V_I = V_{IH}$ or $V_{IL}$ , $I_{OH} = -20 \mu\text{A}$	2 V	1.9	1.998		1.9		1.9			V	
		4.5 V	4.4	4.499		4.4		4.4				
		6 V	5.9	5.999		5.9		5.9				
	$V_I = V_{IH}$ or $V_{IL}$ , $I_{OH} = -4 \text{ mA}$	4.5 V	3.98	4.30		3.7		3.84				
	$V_I = V_{IH}$ or $V_{IL}$ , $I_{OH} = -5.2 \text{ mA}$	6 V	5.48	5.80		5.2		5.34				
$V_{OL}$	$V_I = V_{IH}$ or $V_{IL}$ , $I_{OL} = 20 \mu\text{A}$	2 V		0.002	0.1			0.1			V	
		4.5 V		0.001	0.1			0.1				
		6 V		0.001	0.1			0.1				
	$V_I = V_{IH}$ or $V_{IL}$ , $I_{OL} = 4 \text{ mA}$	4.5 V		0.17	0.26			0.4		0.33		
	$V_I = V_{IH}$ or $V_{IL}$ , $I_{OL} = 5.2 \text{ mA}$	6 V		0.15	0.26			0.4		0.33		
$I_I$	$V_I = V_{CC}$ or 0	6 V	$\pm 0.1 \pm 100$			$\pm 1000$			$\pm 1000$			nA
$I_{CC}$	$V_I = V_{CC}$ or 0, $I_O = 0$	6 V	8			160			80			$\mu\text{A}$
$C_i$		2 to 6 V	3			10			10			pF

**SN54HC283, SN74HC283**  
**4-BIT BINARY FULL ADDERS WITH FAST CARRY**

switching characteristics over recommended operating free-air temperature range (unless otherwise noted),  $C_L = 50$  pF (see Note 1)

PARAMETER	FROM (INPUT)	TO (OUTPUT)	V <sub>CC</sub>	T <sub>A</sub> = 25°C			SN54HC283		SN74HC283		UNIT
				MIN	TYP	MAX	MIN	MAX	MIN	MAX	
t <sub>pd</sub>	C0	Any Σ	2 V	60	150		225		188	ns	
			4.5 V	20	30		45		37		
			6 V	16	26		38		32		
t <sub>pd</sub>	A <sub>i</sub> or B <sub>i</sub>	Σ <sub>i</sub>	2 V	80	175		262		218	ns	
			4.5 V	25	35		52		44		
			6 V	20	30		45		37		
t <sub>pd</sub>	C0	C4	2 V	70	175		262		218	ns	
			4.5 V	25	35		52		44		
			6 V	20	30		45		37		
t <sub>pd</sub>	A <sub>i</sub> or B <sub>i</sub>	C4	2 V	90	175		262		218	ns	
			4.5 V	26	35		52		44		
			6 V	21	30		45		37		
t <sub>t</sub>		Any	2 V	28	75		110		95	ns	
			4.5 V	8	15		22		19		
			6 V	6	13		19		16		

2

HCMOS Devices

C <sub>pd</sub>	Power dissipation capacitance	No load, T <sub>A</sub> = 25°C	90 pF typ
-----------------	-------------------------------	--------------------------------	-----------

NOTE 1: Load circuit and voltage waveforms are shown in Section 1.