

To all our customers

---

## **Regarding the change of names mentioned in the document, such as Hitachi Electric and Hitachi XX, to Renesas Technology Corp.**

---

The semiconductor operations of Mitsubishi Electric and Hitachi were transferred to Renesas Technology Corporation on April 1st 2003. These operations include microcomputer, logic, analog and discrete devices, and memory chips other than DRAMs (flash memory, SRAMs etc.) Accordingly, although Hitachi, Hitachi, Ltd., Hitachi Semiconductors, and other Hitachi brand names are mentioned in the document, these names have in fact all been changed to Renesas Technology Corp. Thank you for your understanding. Except for our corporate trademark, logo and corporate statement, no changes whatsoever have been made to the contents of the document, and these changes do not constitute any alteration to the contents of the document itself.

Renesas Technology Home Page: <http://www.renesas.com>

Renesas Technology Corp.  
Customer Support Dept.  
April 1, 2003

## Cautions

Keep safety first in your circuit designs!

1. Renesas Technology Corporation puts the maximum effort into making semiconductor products better and more reliable, but there is always the possibility that trouble may occur with them. Trouble with semiconductors may lead to personal injury, fire or property damage.  
Remember to give due consideration to safety when making your circuit designs, with appropriate measures such as (i) placement of substitutive, auxiliary circuits, (ii) use of nonflammable material or (iii) prevention against any malfunction or mishap.

Notes regarding these materials

1. These materials are intended as a reference to assist our customers in the selection of the Renesas Technology Corporation product best suited to the customer's application; they do not convey any license under any intellectual property rights, or any other rights, belonging to Renesas Technology Corporation or a third party.
2. Renesas Technology Corporation assumes no responsibility for any damage, or infringement of any third-party's rights, originating in the use of any product data, diagrams, charts, programs, algorithms, or circuit application examples contained in these materials.
3. All information contained in these materials, including product data, diagrams, charts, programs and algorithms represents information on products at the time of publication of these materials, and are subject to change by Renesas Technology Corporation without notice due to product improvements or other reasons. It is therefore recommended that customers contact Renesas Technology Corporation or an authorized Renesas Technology Corporation product distributor for the latest product information before purchasing a product listed herein.  
The information described here may contain technical inaccuracies or typographical errors.  
Renesas Technology Corporation assumes no responsibility for any damage, liability, or other loss rising from these inaccuracies or errors.  
Please also pay attention to information published by Renesas Technology Corporation by various means, including the Renesas Technology Corporation Semiconductor home page (<http://www.renesas.com>).
4. When using any or all of the information contained in these materials, including product data, diagrams, charts, programs, and algorithms, please be sure to evaluate all information as a total system before making a final decision on the applicability of the information and products. Renesas Technology Corporation assumes no responsibility for any damage, liability or other loss resulting from the information contained herein.
5. Renesas Technology Corporation semiconductors are not designed or manufactured for use in a device or system that is used under circumstances in which human life is potentially at stake. Please contact Renesas Technology Corporation or an authorized Renesas Technology Corporation product distributor when considering the use of a product contained herein for any specific purposes, such as apparatus or systems for transportation, vehicular, medical, aerospace, nuclear, or undersea repeater use.
6. The prior written approval of Renesas Technology Corporation is necessary to reprint or reproduce in whole or in part these materials.
7. If these products or technologies are subject to the Japanese export control restrictions, they must be exported under a license from the Japanese government and cannot be imported into a country other than the approved destination.  
Any diversion or reexport contrary to the export control laws and regulations of Japan and/or the country of destination is prohibited.
8. Please contact Renesas Technology Corporation for further details on these materials or the products contained therein.

---

# HD66410

(RAM-Provided 128-Channel Driver for Dot-Matrix  
Graphic LCD)

# HITACHI

---

## Description

The HD66410 drives and controls a dot-matrix graphic LCD using a bit-mapped display method. It provides a highly flexible display through its on-chip display RAM, in which each bit of data can be used to turn on or off one dot on the LCD panel.

A single HD66410 can display a maximum of  $128 \times 33$  dots using its powerful display control functions. It features 24-channel annunciator output operating with 1/3 duty cycle that is available even during standby modes, which makes it suitable for time and other mark indications.

An MPU can access the HD66410 at any time because the MPU operations are asynchronous with the HD66410's system clock and display operations.

Its low-voltage operation at minimum 2.2V and the standby function provides low power-dissipation, making the HD66410 suitable for small portable device applications.

## Features

- 4.2-kbits ( $128 \times 33$ -bit) bit-mapped display RAM
- $128 \times 33$  dots displayed using a single HD66410
  - 8 characters  $\times$  2 lines ( $16 \times 16$ -dot character)
  - 21 characters  $\times$  4 lines ( $6 \times 8$ -dot character)
- Annunciator display using dedicated output channels
  - Maximum of 72 segments displayed with 1/3 duty cycle
  - Available even during standby modes

---

## HD66410

---

- Flexible LCD driver configuration
  - Row output from both sides of an LCD panel
  - Row output from one side of an LCD panel
- Low power-dissipation suitable for long battery-based operation
  - Voltage operation: 2.2 to 5.5V
  - Two standby modes: modes with and without annunciator display
- On-chip double to quadruple booster
- Versatile display control functions
  - Display data read/write
  - Display on/off
  - Column address inversion according to column driver layout
  - Vertical display scroll
  - Blink area select
  - Read-modify-write
- 80-system MPU interface through 8-bit asynchronous data bus
- On-chip oscillator combined with external resistor and capacitor
- Tape carrier package (TCP)

### Ordering Information

Type No.	Package
HD66410TA0	Outer Lead Pitch 300 $\mu$ m (TCP-239)
HCD66410BP	Chip with gold bump

---

Pin Arrangement

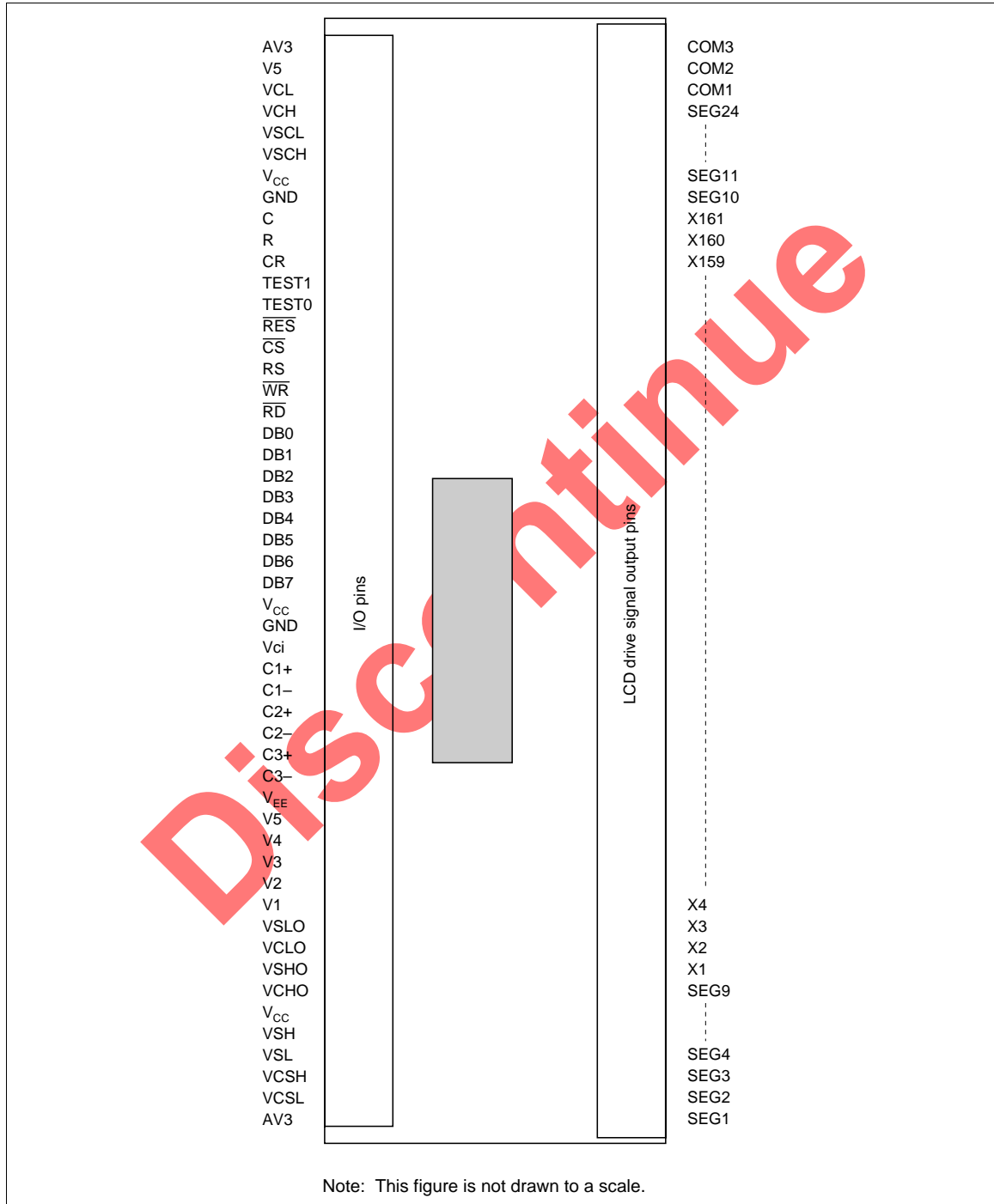

---

## HD66410

---

### HD66410 Pad Arrangement

- Chip size : 14.28 × 2.72mm  
Coordinate : Pad Center  
Orgin : Chip Center  
Bump size : 50 × 70 × 20 μm  
Dummy pad 1: Bump size 70 × 70 × 20 μm (Typ.)  
(DMY-A, DMY-B, DMY-C, DMY-D)  
Dummy pad 2: Bump size 50 × 70 × 20 μm (Typ.)  
(DMY-1 to DMY-40)

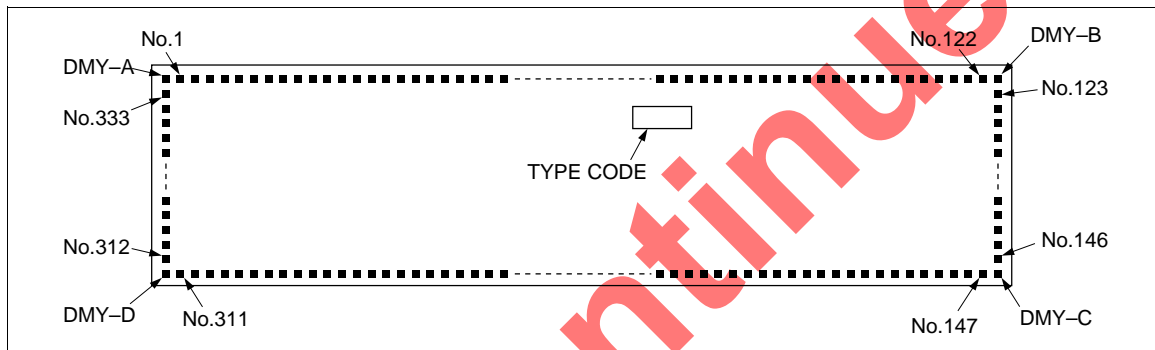

HD66410 Pad Location Coordinates

Pad No.	Pad Name	Coordinate		Pad No.	Pad Name	Coordinate		Pad No.	Pad Name	Coordinate		Pad No.	Pad Name	Coordinate	
		X	Y			X	Y			X	Y			X	Y
1	AV3-1	-6788	1056	51	(V <sub>CC</sub> )	-1727	1202	101	RS	3686	1114	151	X161	6123	-1139
2	(DMY1)	-6708	1056	52	(V <sub>CC</sub> )	-1647	1202	102	CS	3890	1114	152	X160	6043	-1139
3	VCSL	-6628	1056	53	(V <sub>CC</sub> )	-1567	1202	103	RES	4094	1114	153	X159	5963	-1139
4	(DMY2)	-6548	1056	54	(V <sub>CC</sub> )	-1487	1202	104	TEST0	4298	1114	154	X158	5883	-1139
5	VCSH	-6468	1056	55	(V <sub>CC</sub> )	-1407	1202	105	TEST1	4477	1114	155	X157	5803	-1139
6	VSL	-6388	1056	56	(V <sub>CC</sub> )	-1327	1202	106	CR	4685	1114	156	X156	5723	-1139
7	(DMY3)	-6308	1056	57	(V <sub>CC</sub> )	-1247	1202	107	R	4893	1114	157	X155	5643	-1139
8	VSH	-6228	1056	58	(V <sub>CC</sub> )	-1167	1202	108	C	5102	1114	158	X154	5563	-1139
9	V <sub>CC</sub> -1	-6106	1056	59	(V <sub>CC</sub> )	-1087	1202	109	GND-2	5360	1114	159	X153	5483	-1139
10	VCHO	-5961	1056	60	(V <sub>CC</sub> )	-1007	1202	110	GND-3	5440	1114	160	X152	5403	-1139
11	(DMY4)	-5881	1056	61	(V <sub>CC</sub> )	-927	1202	111	V <sub>CC</sub> -3	5711	1114	161	X151	5323	-1139
12	VSHO	-5801	1056	62	(V <sub>CC</sub> )	-847	1202	112	V <sub>CC</sub> -4	5791	1114	162	X150	5243	-1139
13	(DMY5)	-5721	1056	63	(V <sub>CC</sub> )	-767	1202	113	(DMY14)	5975	1114	163	X149	5163	-1139
14	VCMO	-5641	1056	64	(V <sub>CC</sub> )	-687	1202	114	VSCH	6055	1114	164	X148	5083	-1139
15	VSL0	-5561	1056	65	(V <sub>CC</sub> )	-607	1202	115	VSCL	6135	1114	165	X147	5003	-1139
16	(DMY6)	-5481	1056	66	(V <sub>CC</sub> )	-527	1202	116	(DMY15)	6215	1114	166	X146	4923	-1139
17	V1	-5401	1056	67	(V <sub>CC</sub> )	-447	1202	117	VCH	6295	1114	167	X145	4843	-1139
18	(DMY7)	-5321	1020	68	(V <sub>CC</sub> )	-367	1202	118	(DMY16)	6375	1114	168	X144	4763	-1139
19	V2	-5241	1020	69	(V <sub>CC</sub> )	-287	1202	119	VCL	6455	1114	169	X143	4683	-1139
20	V3	-5161	1020	70	(V <sub>CC</sub> )	-207	1202	120	V5-2	6535	1114	170	X142	4603	-1139
21	(DMY8)	-5081	1020	71	(V <sub>CC</sub> )	-127	1202	121	(DMY17)	6663	1114	171	X141	4523	-1139
22	(DMY9)	-5001	1020	72	(V <sub>CC</sub> )	-47	1202	122	AV3-2	6744	1114	172	X140	4443	-1139
23	(DMY10)	-4894	1056	73	(V <sub>CC</sub> )	33	1202	123	(DMY18)	6925	939	173	X139	4363	-1139
24	V4	-4814	1056	74	(V <sub>CC</sub> )	113	1202	124	COM3	6925	769	174	X138	4283	-1139
25	V5-1	-4729	1056	75	(V <sub>CC</sub> )	193	1202	125	COM2	6925	689	175	X137	4203	-1139
26	(DMY11)	-4524	1069	76	(V <sub>CC</sub> )	273	1202	126	COM1	6925	609	176	X136	4123	-1139
27	(DMY12)	-4444	1069	77	(V <sub>CC</sub> )	353	1202	127	SEG24	6925	529	177	X135	4043	-1139
28	V <sub>EE</sub>	-4268	1069	78	(V <sub>CC</sub> )	433	1202	128	SEG23	6925	449	178	X134	3963	-1139
29	C3-	-4178	1069	79	(V <sub>CC</sub> )	513	1202	129	SEG22	6925	369	179	X133	3883	-1139
30	(DMY13)	-3987	1069	80	(V <sub>CC</sub> )	593	1202	130	SEG21	6925	289	180	X132	3803	-1139
31	C3+	-3701	1076	81	(V <sub>CC</sub> )	673	1202	131	SEG20	6925	209	181	X131	3723	-1139
32	C2-	-3621	1076	82	(V <sub>CC</sub> )	753	1202	132	SEG19	6925	129	182	X130	3643	-1139
33	C2+	-3456	1076	83	(V <sub>CC</sub> )	833	1202	133	SEG18	6925	49	183	X129	3563	-1139
34	C1-	-3376	1076	84	(V <sub>CC</sub> )	913	1202	134	SEG17	6925	-31	184	X128	3483	-1139
35	C1+	-3088	1069	85	(V <sub>CC</sub> )	993	1202	135	SEG16	6925	-111	185	X127	3403	-1139
36	VCI	-3008	1069	86	(V <sub>CC</sub> )	1073	1202	136	SEG15	6925	-191	186	X126	3323	-1139
37	GND-1	-2887	1069	87	(V <sub>CC</sub> )	1153	1114	137	SEG14	6925	-271	187	X125	3243	-1139
38	(GND)	-2767	1069	88	(V <sub>CC</sub> )	1233	1114	138	SEG13	6925	-351	188	X124	3163	-1139
39	(GND)	-2687	1069	89	(V <sub>CC</sub> )	1313	1114	139	SEG12	6925	-431	189	X123	3083	-1139
40	(GND)	-2607	1069	90	V <sub>CC</sub> -2	1393	1114	140	SEG11	6925	-511	190	X122	3003	-1139
41	(V <sub>CC</sub> )	-2527	1202	91	DB7	1583	1114	141	SEG10	6925	-591	191	X121	2923	-1139
42	(V <sub>CC</sub> )	-2447	1202	92	DB6	1795	1114	142	(DMY19)	6925	-699	192	X120	2843	-1139
43	(V <sub>CC</sub> )	-2367	1202	93	DB5	2008	1114	143	(DMY20)	6925	-779	193	X119	2763	-1139
44	(V <sub>CC</sub> )	-2287	1202	94	DB4	2220	1114	144	(DMY21)	6925	-859	194	X118	2683	-1139
45	(V <sub>CC</sub> )	-2207	1202	95	DB3	2433	1114	145	(DMY22)	6925	-939	195	X117	2603	-1139
46	(V <sub>CC</sub> )	-2127	1202	96	DB2	2645	1114	146	(DMY23)	6925	-1019	196	X116	2523	-1139
47	(V <sub>CC</sub> )	-2047	1202	97	DB1	2858	1114	147	(DMY24)	6754	-1139	197	X115	2443	-1139
48	(V <sub>CC</sub> )	-1967	1202	98	DB0	3070	1114	148	(DMY25)	6674	-1139	198	X114	2363	-1139
49	(V <sub>CC</sub> )	-1887	1202	99	RD	3278	1114	149	(DMY26)	6594	-1139	199	X113	2283	-1139
50	(V <sub>CC</sub> )	-1807	1202	100	WR	3482	1114	150	(DMY27)	6514	-1139	200	X112	2203	-1139

# HD66410

Pad No.	Pad Name	Coordinate		Pad No.	Pad Name	Coordinate		Pad No.	Pad Name	Coordinate		Pad No.	Pad Name	Coordinate	
		X	Y			X	Y			X	Y			X	Y
201	X111	2123	-1139	236	X76	-677	-1139	271	X41	-3477	-1139	306	X6	-6277	-1139
202	X110	2043	-1139	237	X75	-757	-1139	272	X40	-3557	-1139	307	X5	-6357	-1139
203	X109	1963	-1139	238	X74	-837	-1139	273	X39	-3637	-1139	308	X4	-6437	-1139
204	X108	1883	-1139	239	X73	-917	-1139	274	X38	-3717	-1139	309	X3	-6517	-1139
205	X107	1803	-1139	240	X72	-997	-1139	275	X37	-3797	-1139	310	X2	-6597	-1139
206	X106	1723	-1139	241	X71	-1077	-1139	276	X36	-3877	-1139	311	X1	-6677	-1139
207	X105	1643	-1139	242	X70	-1157	-1139	277	X35	-3957	-1139	312	(DMY28)	-6935	-1018
208	X104	1563	-1139	243	X69	-1237	-1139	278	X34	-4037	-1139	313	(DMY29)	-6935	-938
209	X103	1483	-1139	244	X68	-1317	-1139	279	X33	-4117	-1139	314	(DMY30)	-6935	-858
210	X102	1403	-1139	245	X67	-1397	-1139	280	X32	-4197	-1139	315	(DMY31)	-6935	-778
211	X101	1323	-1139	246	X66	-1477	-1139	281	X31	-4277	-1139	316	(DMY32)	-6935	-698
212	X100	1243	-1139	247	X65	-1557	-1139	282	X30	-4357	-1139	317	(DMY33)	-6935	-618
213	X99	1163	-1139	248	X64	-1637	-1139	283	X29	-4437	-1139	318	(DMY34)	-6935	-538
214	X98	1083	-1139	249	X63	-1717	-1139	284	X28	-4517	-1139	319	(DMY35)	-6935	-458
215	X97	1003	-1139	250	X62	-1797	-1139	285	X27	-4597	-1139	320	(DMY36)	-6935	-378
216	X96	923	-1139	251	X61	-1877	-1139	286	X26	-4677	-1139	321	(DMY37)	-6935	-298
217	X95	843	-1139	252	X60	-1957	-1139	287	X25	-4757	-1139	322	(DMY38)	-6935	-218
218	X94	763	-1139	253	X59	-2037	-1139	288	X24	-4837	-1139	323	(DMY39)	-6935	-138
219	X93	683	-1139	254	X58	-2117	-1139	289	X23	-4917	-1139	324	(DMY40)	-6935	-58
220	X92	603	-1139	255	X57	-2197	-1139	290	X22	-4997	-1139	325	SEG9	-6927	99
221	X91	523	-1139	256	X56	-2277	-1139	291	X21	-5077	-1139	326	SEG8	-6927	179
222	X90	443	-1139	257	X55	-2357	-1139	292	X20	-5157	-1139	327	SEG7	-6927	259
223	X89	363	-1139	258	X54	-2437	-1139	293	X19	-5237	-1139	328	SEG6	-6927	339
224	X88	283	-1139	259	X53	-2517	-1139	294	X18	-5317	-1139	329	SEG5	-6927	419
225	X87	203	-1139	260	X52	-2597	-1139	295	X17	-5397	-1139	330	SEG4	-6927	499
226	X86	123	-1139	261	X51	-2677	-1139	296	X16	-5477	-1139	331	SEG3	-6927	579
227	X85	43	-1139	262	X50	-2757	-1139	297	X15	-5557	-1139	332	SEG2	-6927	659
228	X84	-37	-1139	263	X49	-2837	-1139	298	X14	-5637	-1139	333	SEG1	-6927	739
229	X83	-117	-1139	264	X48	-2917	-1139	299	X13	-5717	-1139	334	(DMY-A)	-6927	927
230	X82	-197	-1139	265	X47	-2997	-1139	300	X12	-5797	-1139	335	(DMY-B)	6925	1114
231	X81	-277	-1139	266	X46	-3077	-1139	301	X11	-5877	-1139	336	(DMY-C)	6925	-1139
232	X80	-357	-1139	267	X45	-3157	-1139	302	X10	-5957	-1139	337	(DMY-D)	-6935	-1139
233	X79	-437	-1139	268	X44	-3237	-1139	303	X9	-6037	-1139				
234	X78	-517	-1139	269	X43	-3317	-1139	304	X8	-6117	-1139				
235	X77	-597	-1139	270	X42	-3397	-1139	305	X7	-6197	-1139				

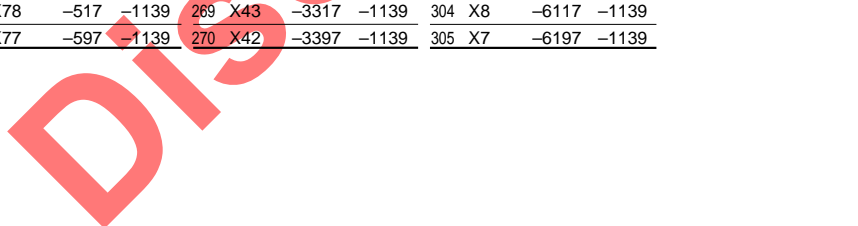

**Pin Description**

Pin Name	Number of Pins	I/O	Connected to	Description
V <sub>CC</sub> , GND	5	—	Power supply	V <sub>CC</sub> : +2.2 to +5.5V, GND: 0V
V <sub>ci</sub>	1	—	Power supply	Inputs voltage to the booster to generate the base of the LCD drive voltages (V <sub>EE</sub> ); must be below V <sub>CC</sub> . V <sub>ci</sub> : 0 to +3.6V.
AV3	2	—	Power supply	Supplies power to the internal annunciator drivers to generate the annunciator drive voltages using AV3 and V <sub>CC</sub> . V <sub>CC</sub> -AV3: 0 to 3.6V; must be above GND.
V <sub>EE</sub>	1	—	Booster capacitors and V5	Boosts and outputs the voltage input to the V <sub>ci</sub> pin; must be connected to the booster capacitors and V5 pin.
V5	2	—	V <sub>EE</sub> Resistive divider	Power supply for LCD driving circuit. Supplies several levels of power to the internal LCD drivers for dot-matrix display; must be connected to the V <sub>EE</sub> pin.
V1, V2, V3, V4	4	—	Resistive divider	Supplies several levels of power to the internal LCD drivers for dot-matrix display; must be applied with the appropriate level of bias for the LCD panel used.
C1+ to C3+, C1- to C3-	6	—	Booster capacitor	Must be connected to external capacitors according to the boosting ratio.
VSHO, VSLO	2	O	VSH, VSL, VCSH, VCSL, (VSCH, VSCL)	Output voltage to be supplied to the internal column drivers.
VCHO, VCLO	2	O	VCH, VCL, VCSH, VCSL, (VSCH, VSCL)	Output voltage to be supplied to the internal row drivers.
VSH, VSL	2	I	VSHO, VSLO	Input voltage to be supplied to internal drivers X17 to X128.
VCH, VCL	2	I	VCHO, VCLO	Input voltage to be supplied to internal drivers X145 to X160.
VCSH, VCSL	2	I	VCHO, VCLO, VSHO, VSLO	Input voltage to be supplied to internal drivers X1 to X16.
VSCH, VSCL	2	I	VCHO, VCLO, VSHO, VSLO	Input voltage to be supplied to internal drivers X129 to X144.
C, R, CR	3	I, I/O	Oscillator resistor and capacitor	Must be connected to external capacitors and resistors when using R-C oscillation. When using an external clock, it must be input to the CR pin.
RES	1	I	—	Resets the LSI internally when driven low.
CS	1	I	MPU	Selects the LSI, specifically internal registers (index and data registers) when driven low.
RS	1	I	MPU	Selects one of the internal registers; selects the index register when driven low and data registers when driven high.
WR	1	I	MPU	Inputs write strobe; allows a write access when driven low.

---

**HD66410**

---

Pin Name	Number of Pins	I/O	Connected to	Description
$\overline{\text{RD}}$	1	I	MPU	Inputs read strobe; allows a read access when driven low.
DB7 to DB0	8	I/O	MPU	8-bit three-state bidirectional data bus; transfers data between the HD66410 and MPU through this bus.
X1 to X16, X129 to X144	32	O	Liquid crystal display	Output column or row drive signals; either column or row can be selected by programming.
X17 to X128	112	O	Liquid crystal display	Output column drive signals.
X145 to X161	17	O	Liquid crystal display	Output row drive signals.
COM1 to COM3	3	O	Liquid crystal display	Output row drive signals for annunciator display; available even during standby modes. Can operate statically or with 1/3 duty cycle.
SEG1 to SEG24	24	O	Liquid crystal display	Output column drive signals for annunciator display; available even during standby modes.
TEST0	1	I	GND	Tests the LSI; must be grounded.
TEST1	1	O	—	Tests the LSI; must be left unconnected.

Discontinued



# HD66410

## Block Diagram

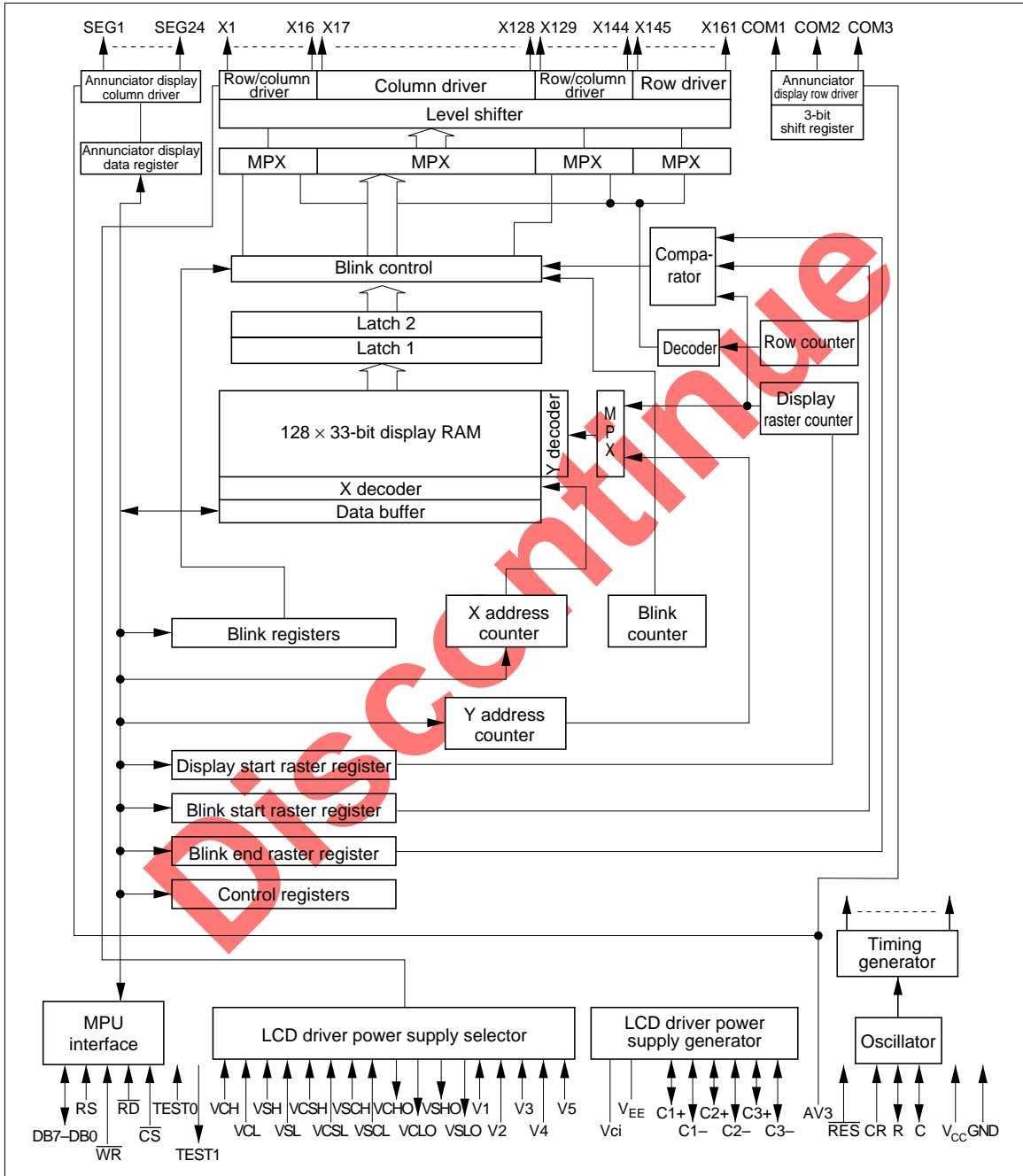

**System Description**

The HD66410 comprises two kinds of independent LCD drivers: one operating with 1/33 or 1/17 duty cycle for dot-matrix displays and the other operating statically or with 1/3 duty cycle for annunciator displays. These drivers can display a maximum of 128 × 33 dots (eight 16 × 16-dot characters × 2 lines) on an LCD panel together with a 72-segment annunciator. Annunciator display is available even during standby modes, thus enabling constant display such as for a time function. The HD66410 can reduce power dissipation without affecting display because data is retained in the display RAM even during standby modes. An LCD system can be configured simply by attaching external capacitors and resistors (Figure 1) since the HD66410 incorporates booster circuits.

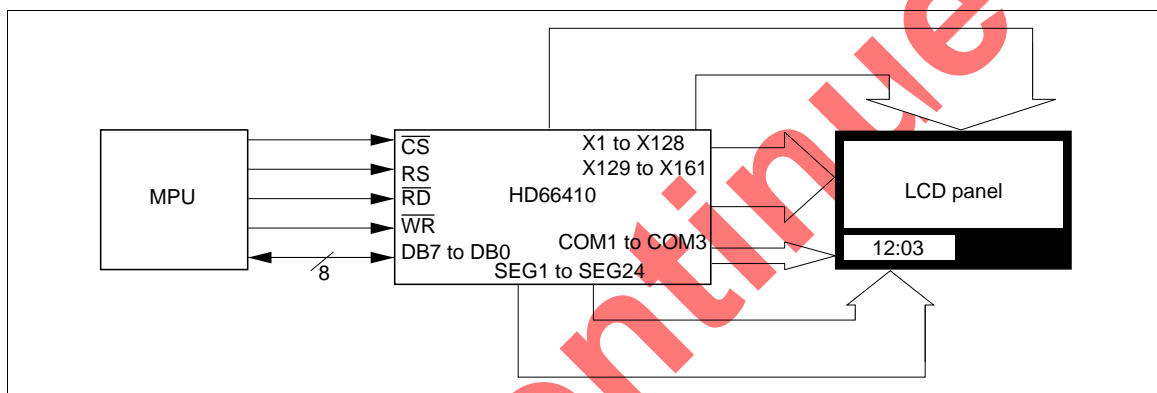

**Figure 1 System Block Diagram**

## HD66410

### MPU Interface

The HD66410 can interface directly to an MPU through an 8-bit data bus or through an I/O port (Figure 2). The MPU can access the HD66410 internal registers independent of internal clock timing.

The index register can be directly accessed but the other registers (data registers) cannot. Before accessing a data register, its register number must be written to the index register. Once written, the register number is held until it is rewritten, enabling the same register to be consecutively accessed without having to rewrite to the register number for each access. An example of a register access sequence is shown in Figure 3.

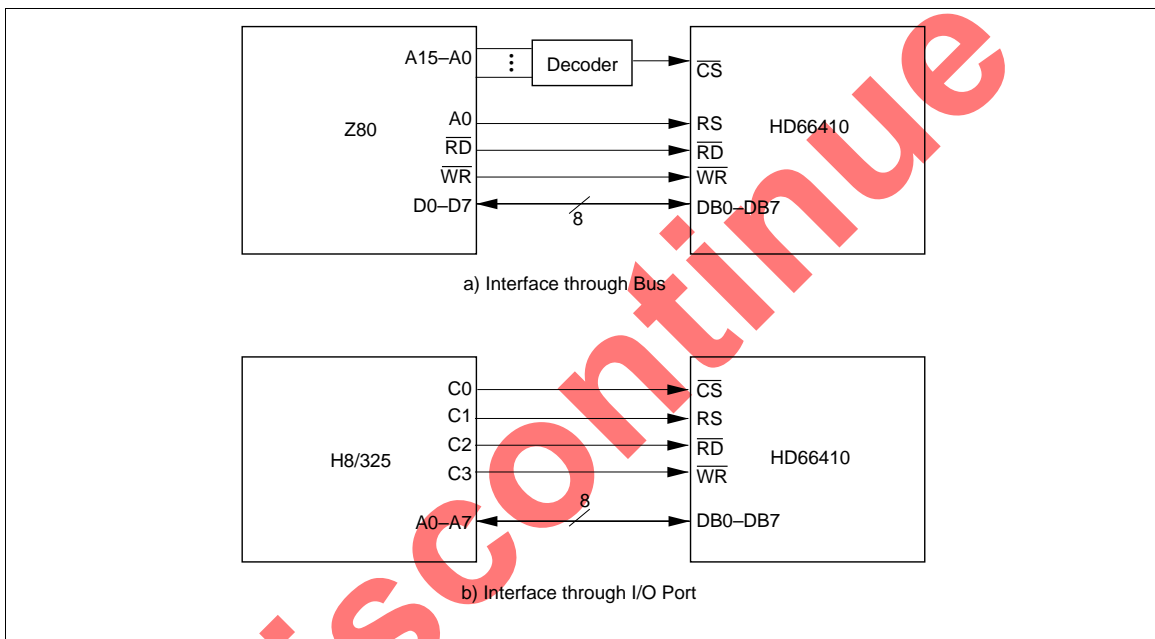

**Figure 2 8-Bit MPU Interface Examples**

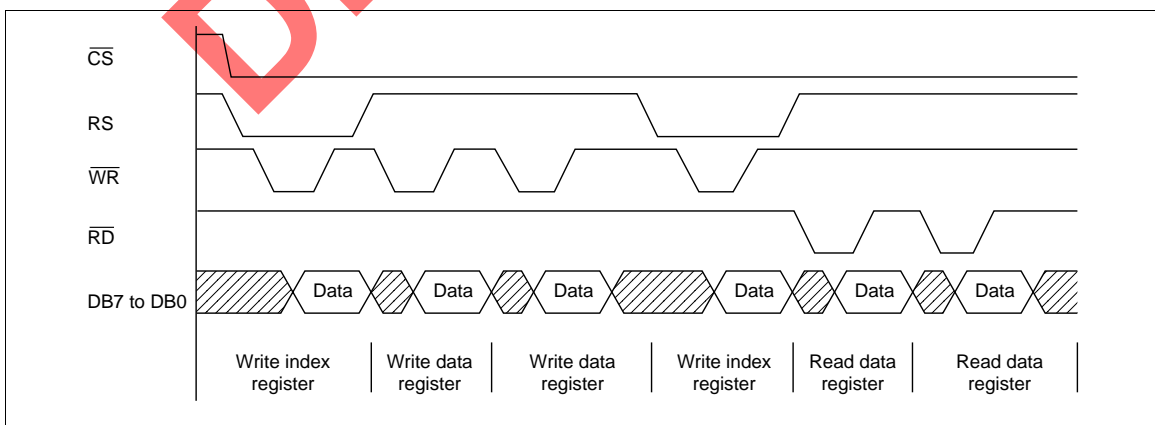

**Figure 3 8-Bit Data Transfer Sequence**

**LCD Driver Configuration**

**Row/Column Output Assignment:** The HD66410 can assign LCD driver output pins X1 to X16 and X129 to X144 to either row or column output depending on the CNF bit value in control register 1, while X17 to X128 and X145 to X161 are fixed to column output and row output, respectively. With this function, row output can be positioned on either one side or two sides of an LCD panel. Figure 4 shows an example where 33-channel row output is positioned to the right of an LCD panel, with X129 to X144 assigned to row output and X1 to X16 assigned to column output. Figure 5 shows an example where 33-channel row output is divided into two and positioned to the right and left of the LCD panel, with X129 to X144 assigned to column output and X1 to X16 assigned to row output. These assignment are valid in the case of 1/17 display duty. Only seventeen X terminals output row signal; unselected signal is output from the rest of terminals which are assigned to row output.

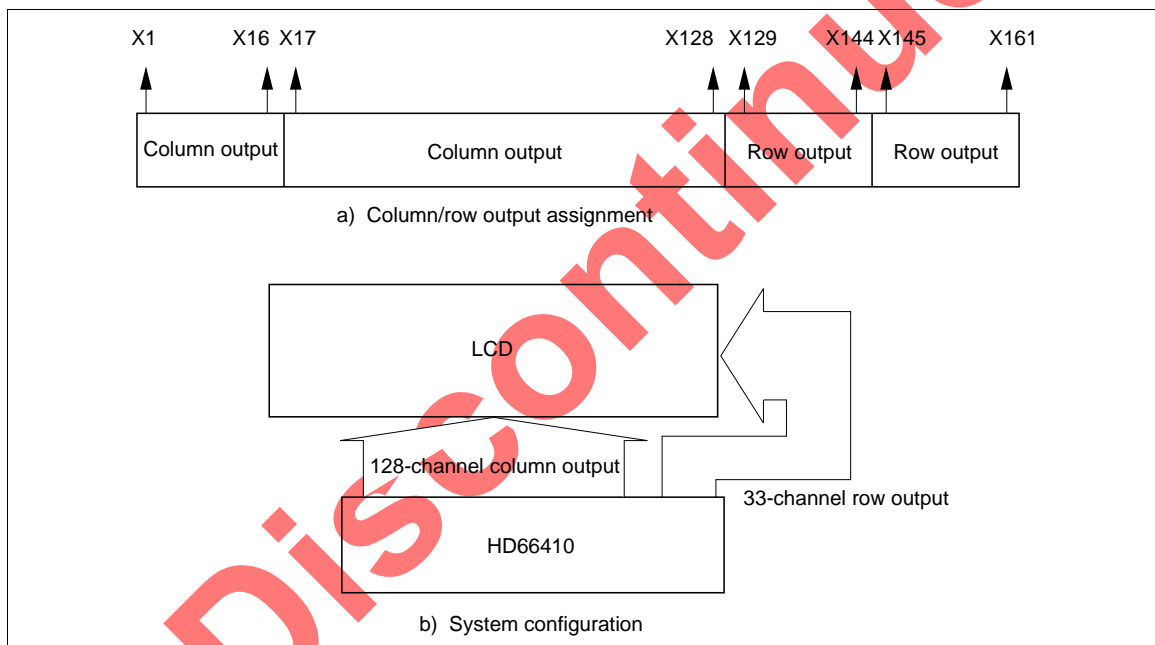
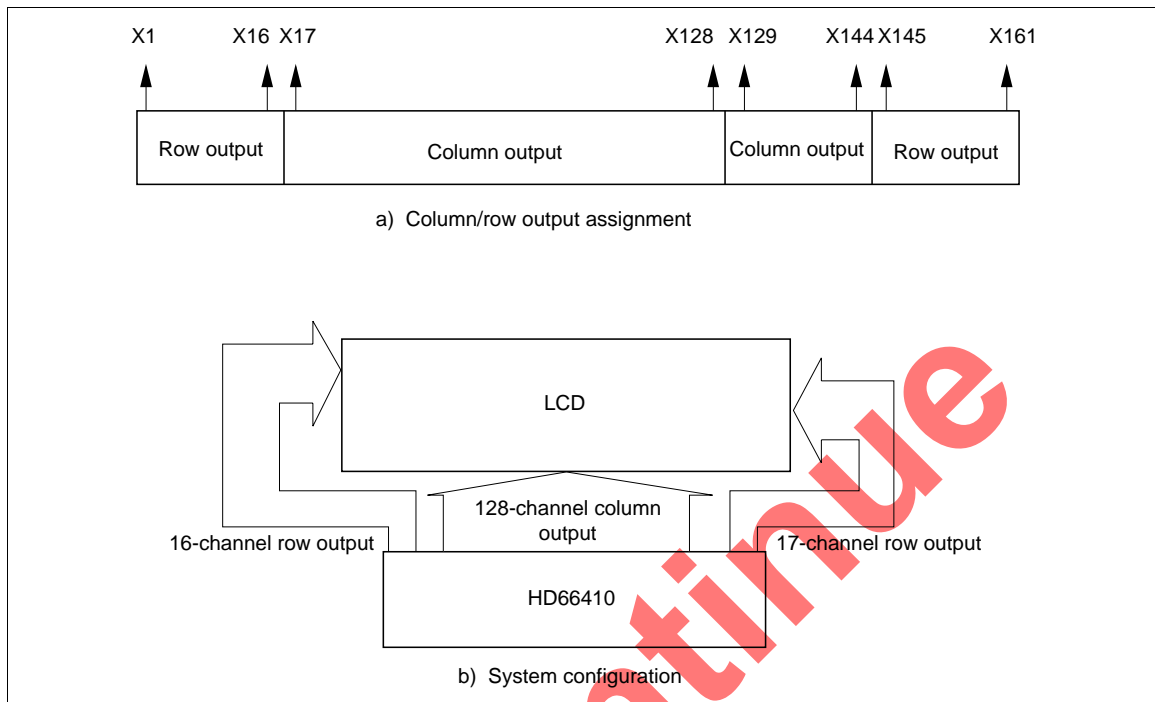

**Figure 4 Row Output on Right Side**

---

**HD66410**

---



**Figure 5 Row Output on Right and Left Sides**

Discontinued

**Column Address Inversion According to LCD Driver Layout:** The HD66410 can always display data in address H'0 on the top left of an LCD panel regardless of where it is positioned with respect to the panel. This is because the HD66410 can invert the positional relationship between display RAM addresses and LCD driver output pins by inverting RAM addresses. Specifically, the HD66410 outputs data in address H'0 from X1 (X17) when the ADC bit in control register 1 is 0, and from X128 (X144) otherwise. Here, the scan direction of row output is also inverted according to the situation, as shown in Figure 6. Note that addresses and scan direction are inverted when data is written to the display RAM, and thus changing the ADC bit after data has been written has no effect. Therefore, hardware control bits such as CNF and ADC must be set immediately after reset is canceled, and must not be set while data is being displayed.

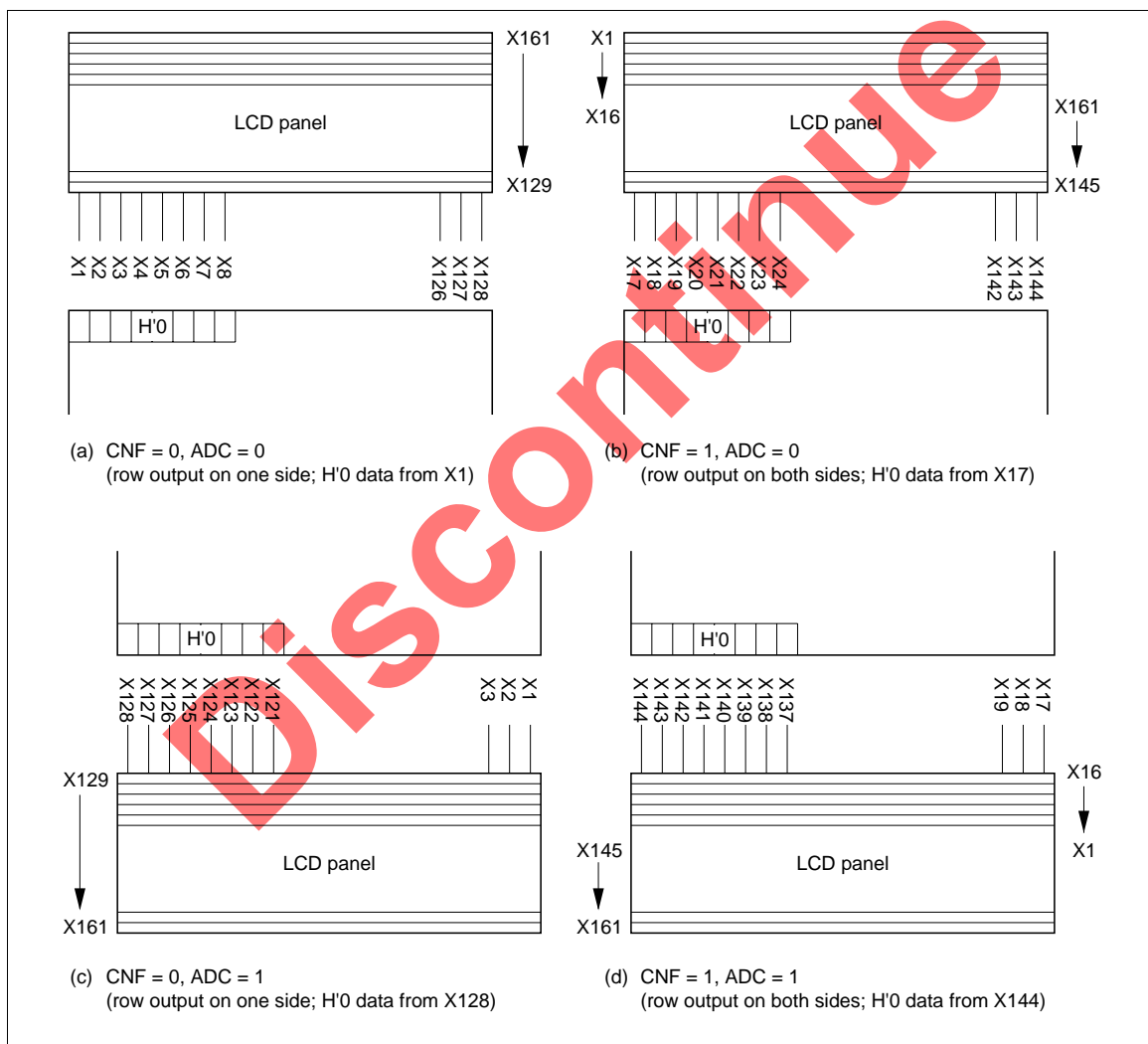

Figure 6 LCD Driver Layout and RAM Addresses (1/33 Duty)

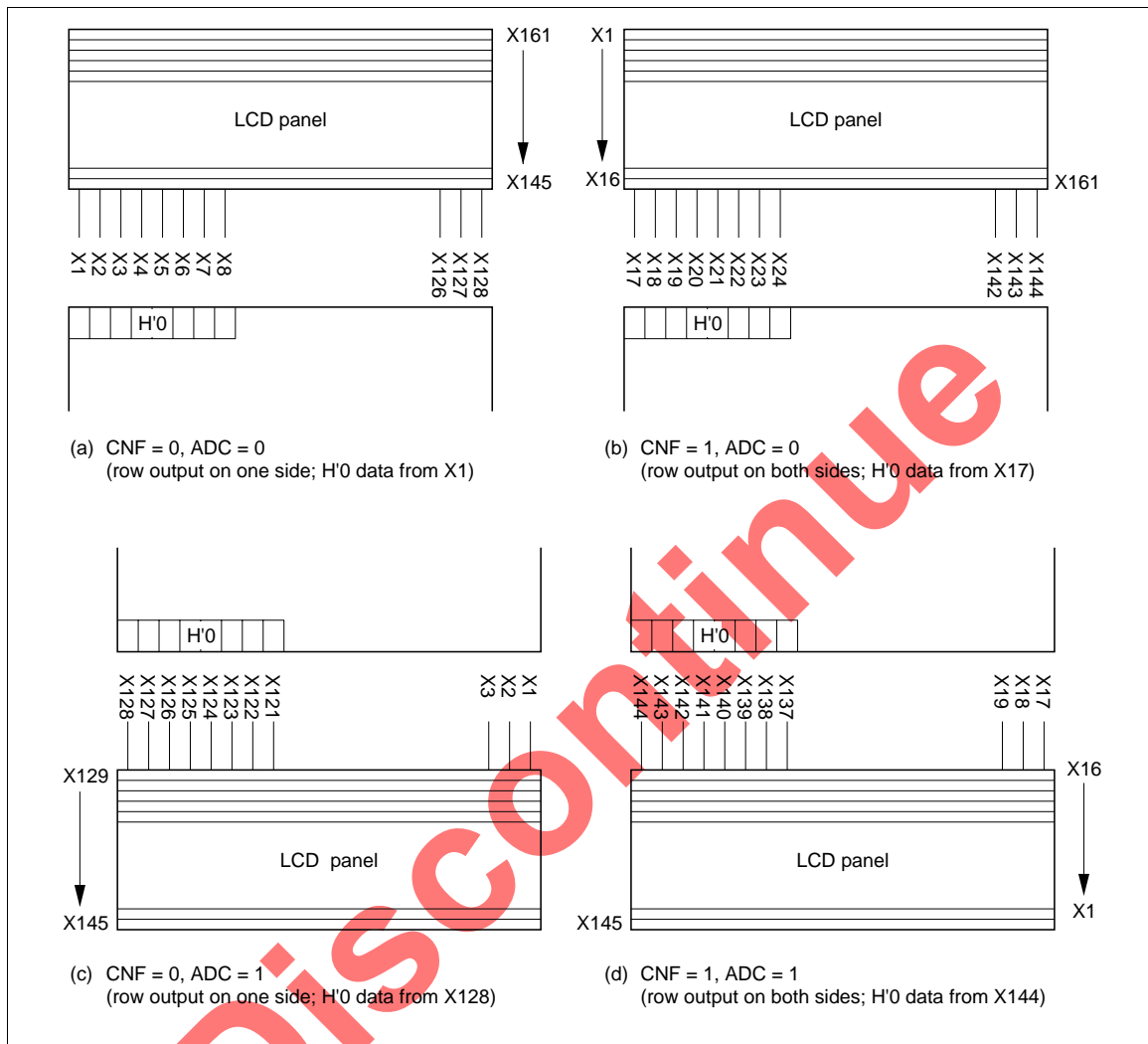
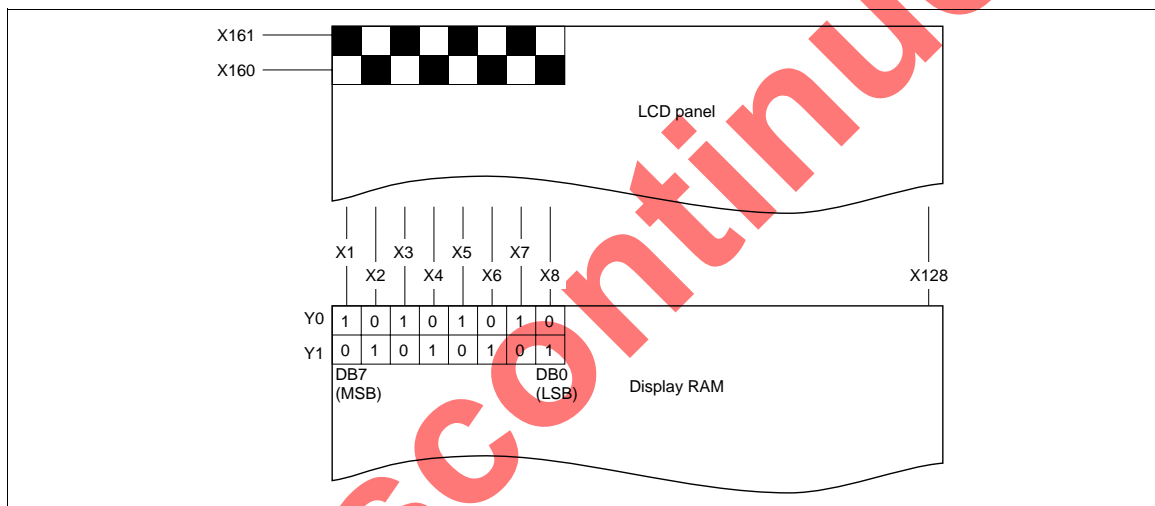

Figure 7 LCD Driver Layout and RAM Addresses (1/17 Duty)

**Display RAM Configuration and Display**

The HD66410 incorporates a bit-mapped display RAM. It has 128 bits in the X direction and 33 bits in the Y direction. The 128 bits are divided into sixteen 8-bit groups. As shown in Figure 8, data written by the MPU is stored horizontally with the MSB at the far left and the LSB at the far right. A display data of 1 turns on (black) the corresponding dot of an LCD panel and 0 turns it off (transparent).

The ADC bit of control register 1 can control the positional relationship between X addresses of the RAM and LCD driver output (Figure 9). Specifically, the data in address H'0 is output from X1 (X17) when the ADC bit in control register 1 is 0, and from X128 (X144) otherwise. Here, data in each 8-bit group is also inverted. Because of this function, the data in X address H'0 can be always displayed on the top left of an LCD panel with the MSB at the far left regardless of the LSI is positioned with respect to the panel.



**Figure 8 Display RAM Data and Display**

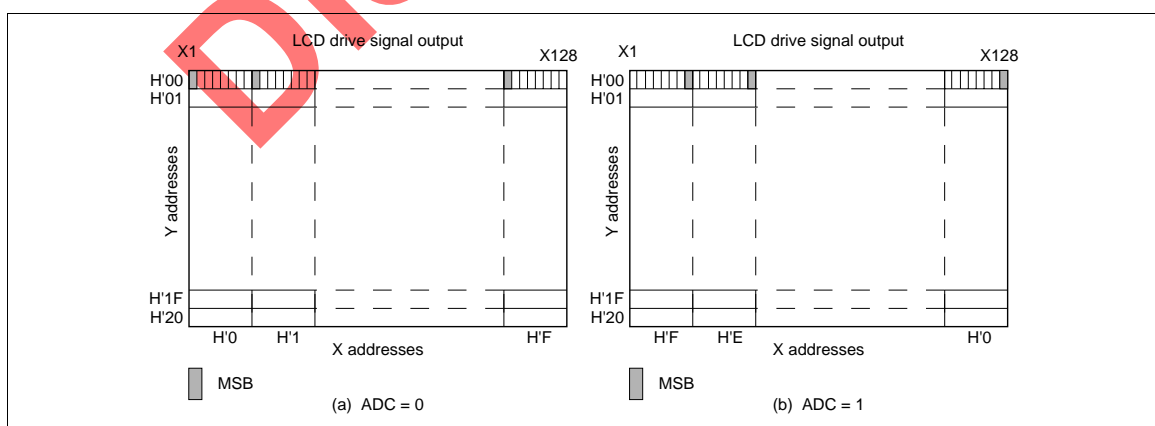

**Figure 9 Display RAM Configuration**

## HD66410

### Access to Internal Registers and Display RAM

**Access to Internal Registers by the MPU:** The internal registers include the index register and data registers. The index register can be accessed by driving both the  $\overline{CS}$  and RS signals low. To access a data register, first write its register number to the index register with RS set to 0, and then access the data register with RS set to 1. Once written, the register number is held until it is rewritten, enabling the same register to be consecutively accessed without having to rewrite to the register number for each access. Some data registers contain unused bits; they should be set to 0. Note that all data registers except the display memory access register can only be written to.

**Access to Display RAM by the MPU:** To access the display RAM, first write the RAM address desired to the X address register (R2) and the Y address register (R3). Then read/write the display memory access register (R4). Memory access by the MPU is independent of memory read by the HD66410 and is also asynchronous with the system clock, thus enabling an interface independent of HD66410's internal operations. However, when reading, data is temporarily latched into a HD66410's buffer and then output next time a read is performed in a subsequent cycle. This means that a dummy read is necessary after setting X and Y addresses. The memory read sequence is shown in Figure 10.

X and Y addresses are automatically incremented after each memory access according to the INC bit value in control register 2; therefore, it is not necessary to update the addresses for each access. Figure 11 shows two cases of incrementing display RAM address. When the INC bit is 0, the Y address will be incremented up to H'3F with the X address unchanged. However, actual memory is valid only within H'00 to H'20; accessing an invalid address is ignored. When the INC bit is 1, the X address will be incremented up to H'F with the Y address unchanged. After address H'F, the X address will return to H'0; if more than 16 bytes of data are consecutively written, data will be overwritten at the same address.

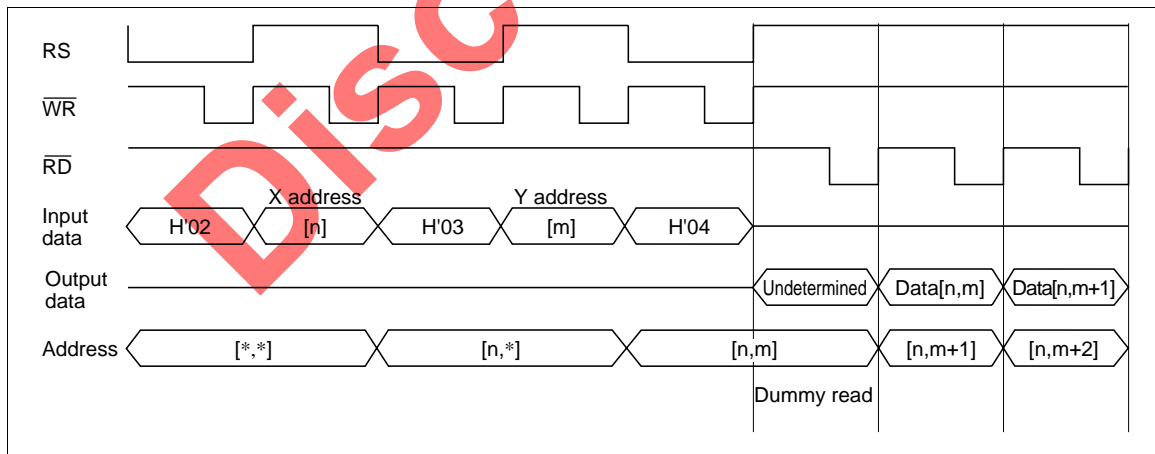

Figure 10 Display RAM Read Sequence

**Display RAM Reading by LCD Controller:** Data is read by the HD66410 to be displayed asynchronously with accesses by the MPU. However, because simultaneous access could damaging data in the display RAM, the HD66410 internally arbitrates access timing; access by the MPU usually has priority and so access by the HD66410 is placed between accesses by the MPU. Accordingly, an appropriate time must be secured (see the given electrical characteristics between two accesses by the MPU).

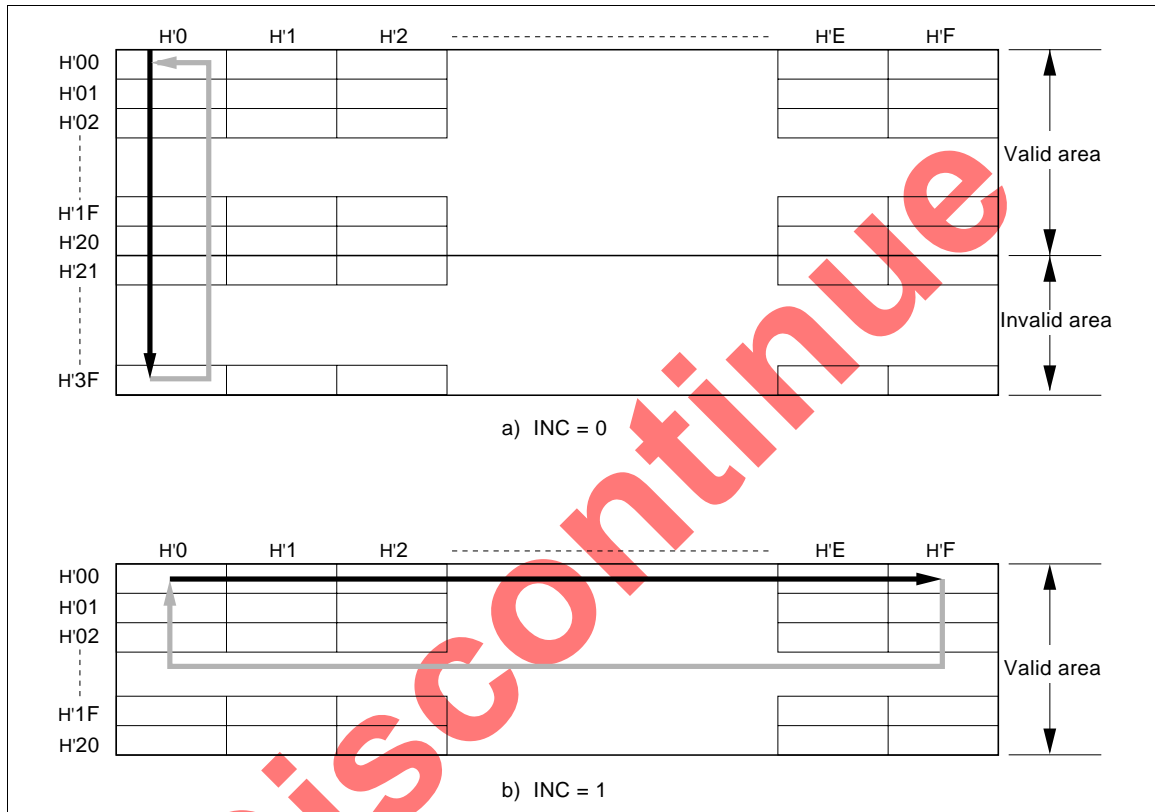

Figure 11 Display RAM Address Increment

---

## HD66410

---

**Read-Modify-Write:** X- or Y-address is incremented after reading from or writing data to the display RAM at normal mode. However, X- or Y-address is not incremented after reading data from the display RAM at read-modify-write mode. The data which is read from the display RAM may be modified and written to the same address without resetting the address. Data is temporarily latched into a HD66410's buffer and then output next time a read is performed in a subsequent cycle. This means that the dummy read is necessary after every cycle. This sequence is shown in Figure 12.

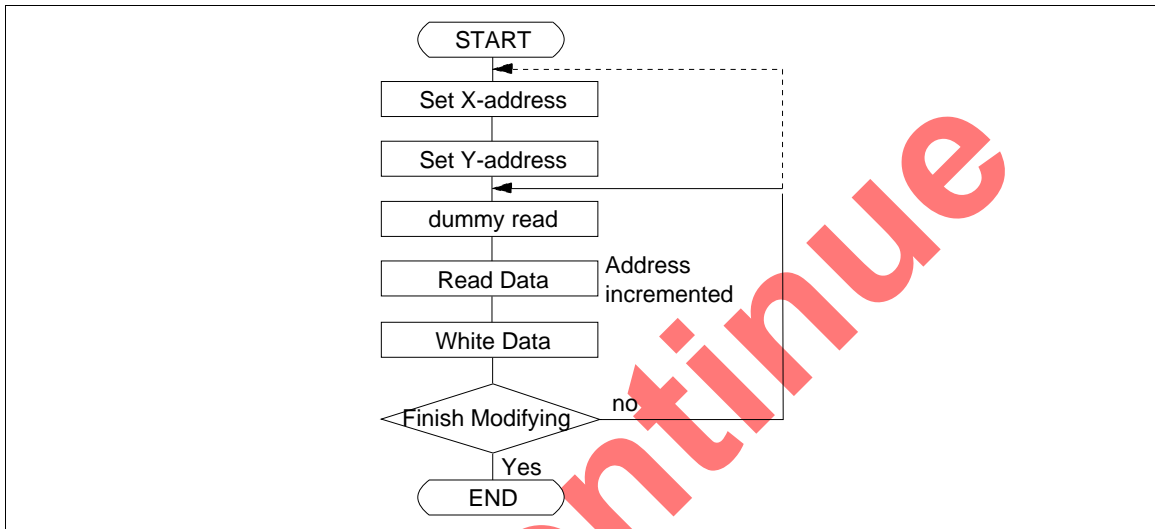
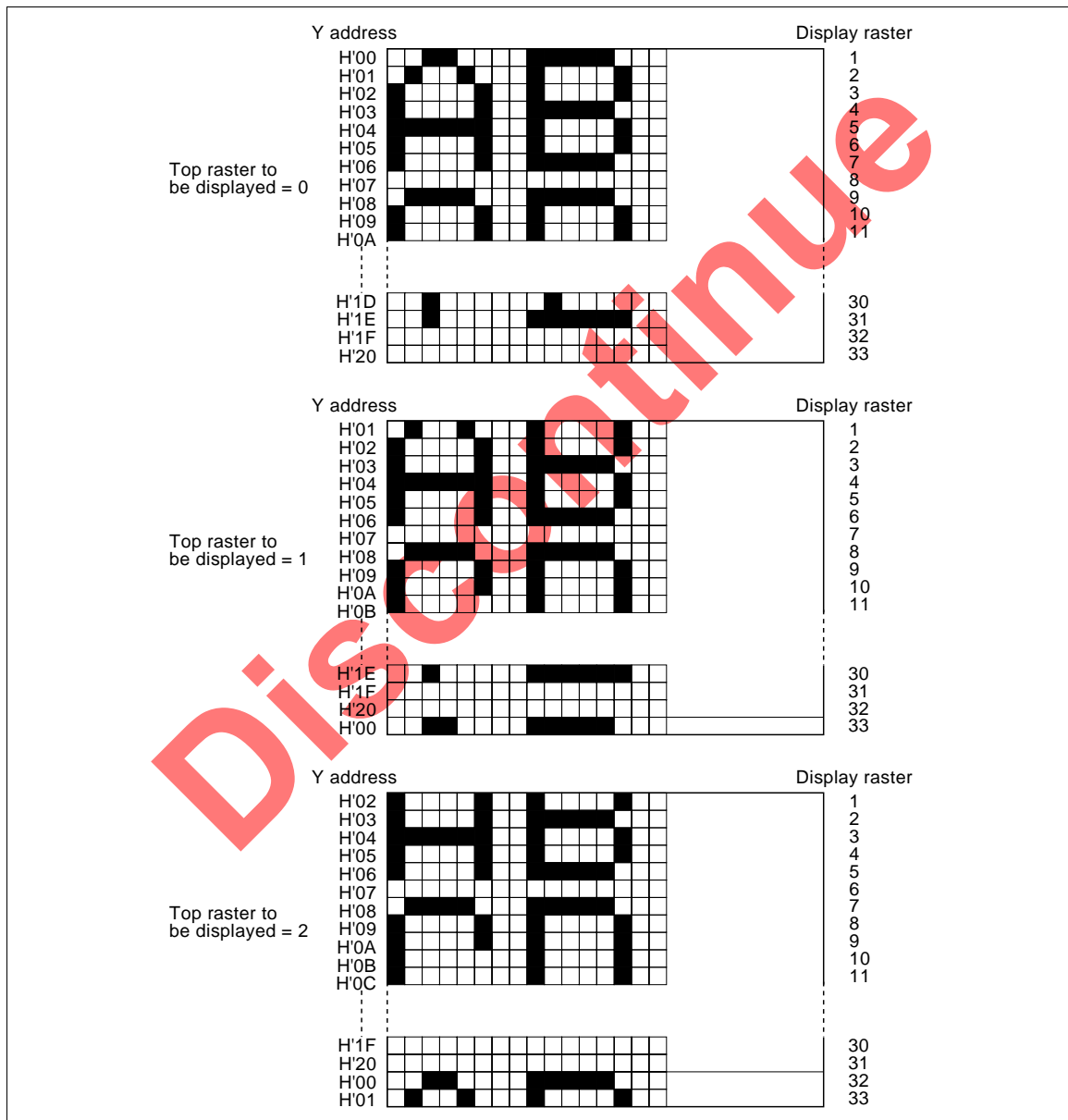

Figure 12 The Flow Chart for Read-Modify-Write

**Vertical Scroll Function**

The HD66410 can vertically scroll a display by varying the top raster to be displayed, which is specified by the display start raster register. Figure 13 and 14 show vertical scroll examples. As shown, when the top raster to be displayed is set to 1, data in Y address H'00 is displayed on the 33rd raster. To display another frame on the 33rd raster, therefore, data in Y address H'00 must be modified after setting the top raster.



**Figure 13 Vertical Scroll (1/33 Duty)**

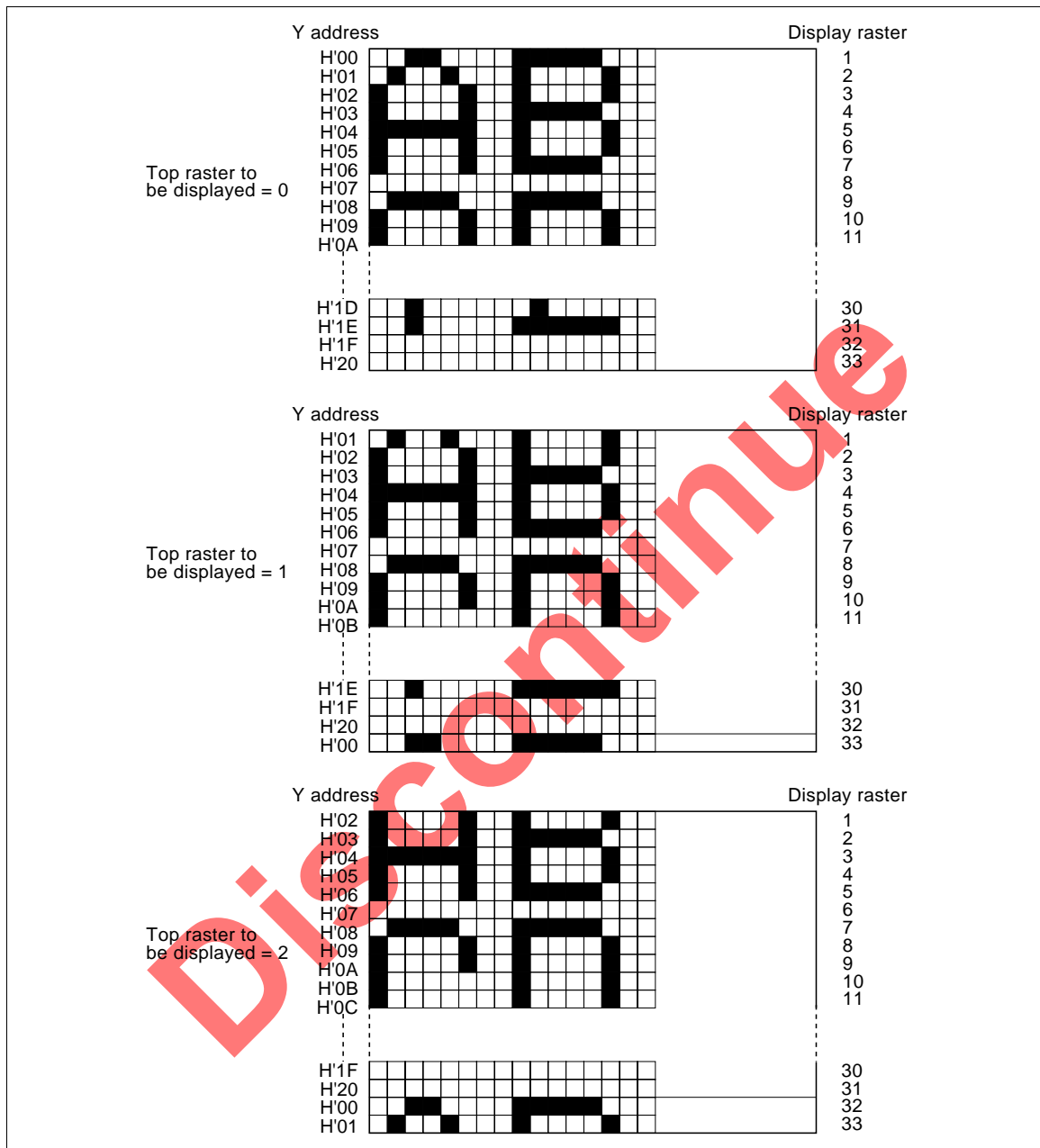
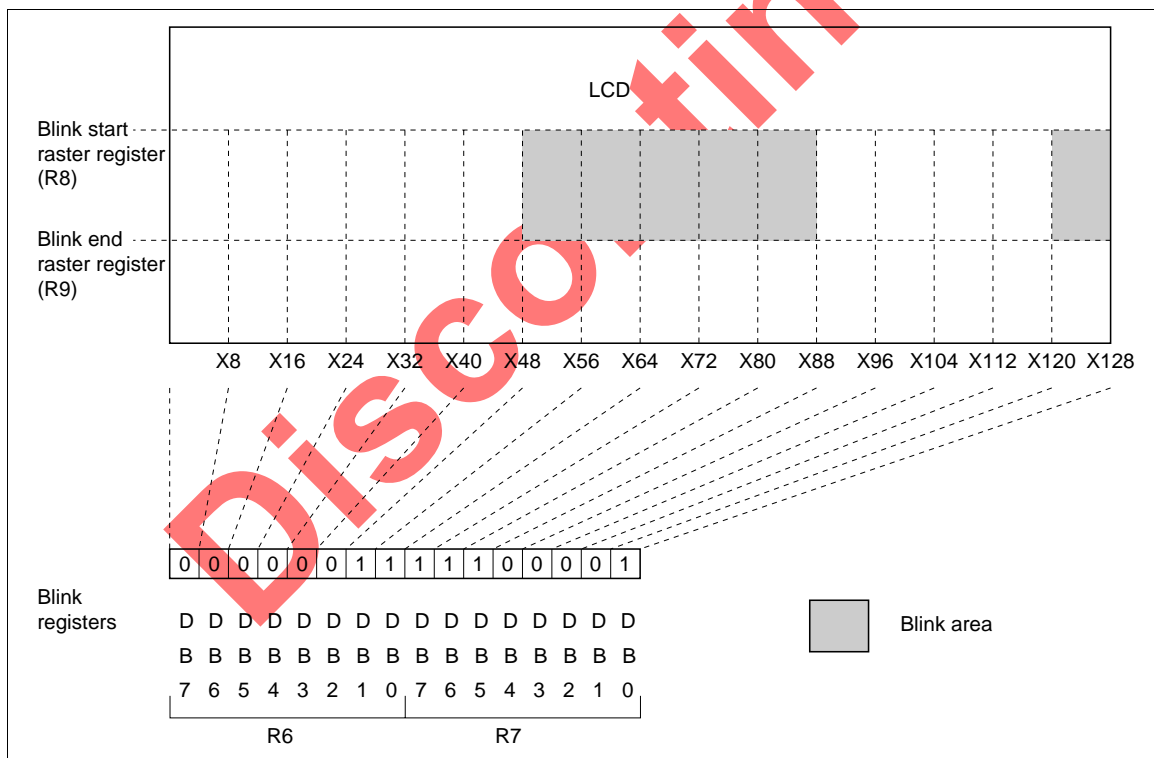

Figure 14 Vertical Scroll (1/17 Duty)

**Blink Function**

**Blinking Dot-Matrix Display Area:** The HD66410 can blink a specified area on the dot-matrix display. Blinking is achieved by repeatedly turning on and off the specified area at a frequency of one sixty-fourth the frame frequency. For example, when the frame frequency is 80 Hz, the area is turned on and off every 0.8 seconds.

The area to be blinked can be designated by specifying vertical and horizontal positions of the area. The vertical position, or the rasters to be blinked, are specified by the blink start raster register (R8) and blink end raster register (R9). The horizontal position, or the dots to be blinked in the specified rasters, are specified by the blink registers (R6 and R7) in an 8-dot group; each data bit in the blink registers controls its corresponding 8-dot group. The relationship between the registers and blink area is shown in Figure 15. Setting the BLK bit to 1 in control register 2 after setting the above registers starts blinking the designated area. Note that since the area to be blinked is designated absolutely with respect to the display RAM, it will move along with a scrolling display (Figure 16).



**Figure 15 Blink Area Designation by Blink Control Registers**

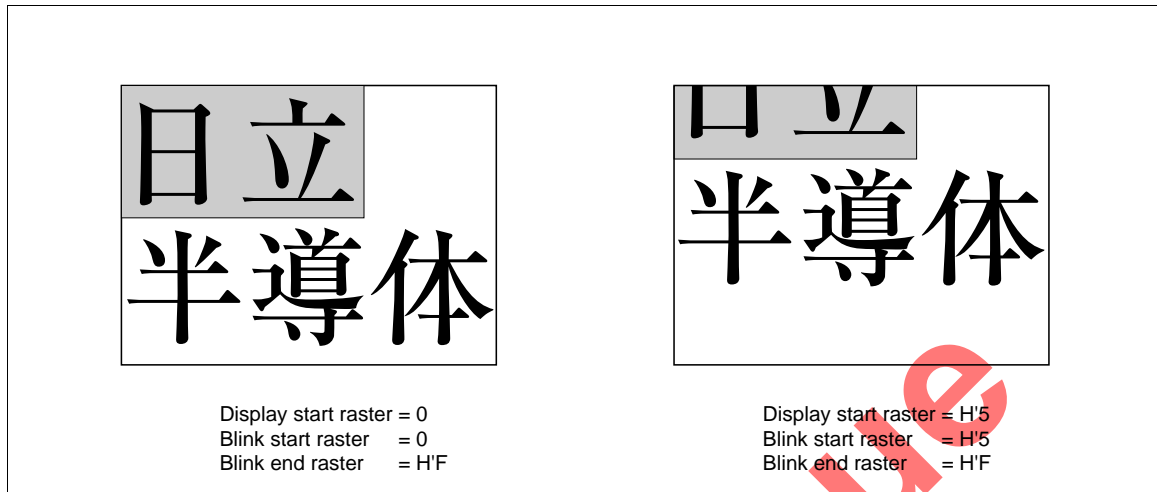

Figure 16 Scrolling Blink Area

Discontinued

**Blinking Annunciator Display Area:** The HD66410 can blink up to 18 dots among a maximum of 72 dots on the annunciator display. This function is controlled by a blink controller independent of that for the main dot-matrix display part. The dots to be blinked can be designated by annunciator blink registers 1, 2, and 3, each of which contains two bits to specify a block and six bits to specify dots to be blinked in the specified block (Figures 17 and 18).

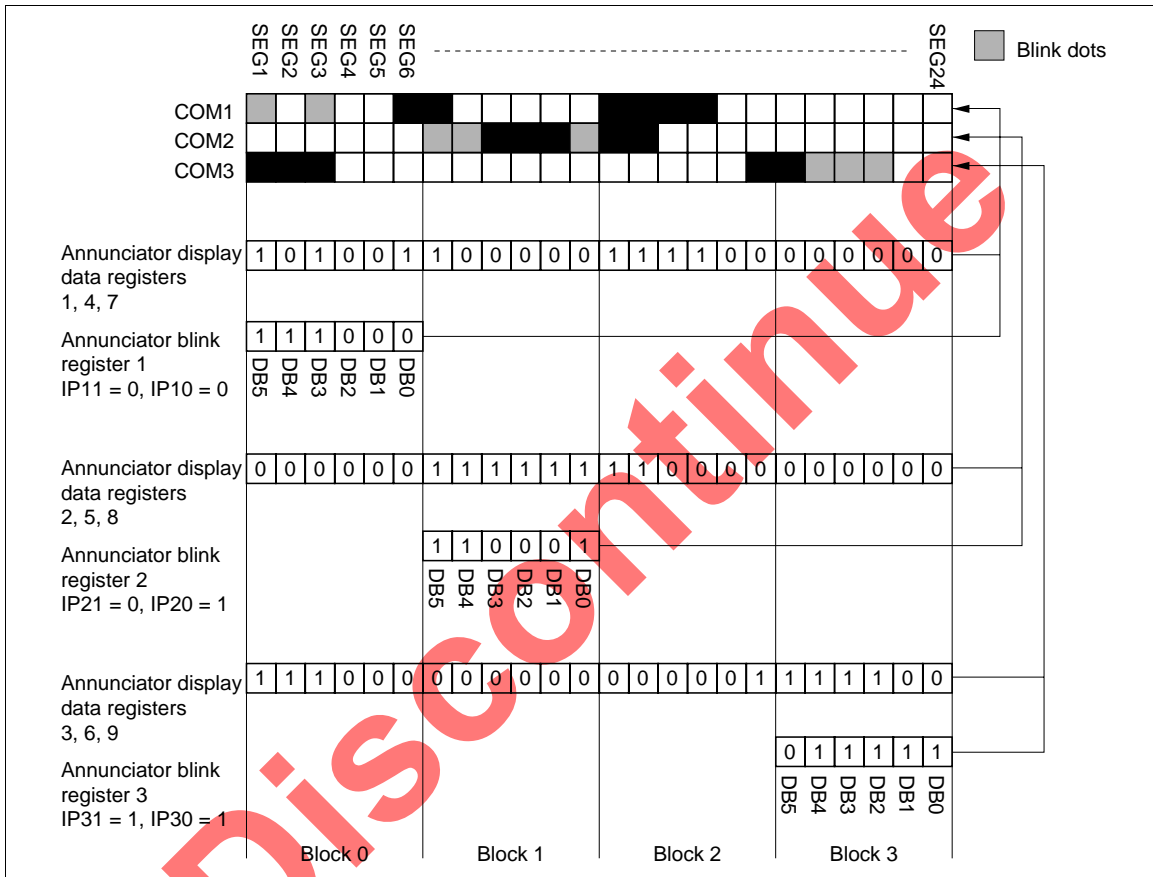

Figure 17 Blink Area Designation by Annunciator Blink Control Registers

	DB7	DB6	DB5	DB4	DB3	DB2	DB1	DB0
Annunciator blink register 1	IP11	IP10	IB15	IB14	IB13	IB12	IB11	IB10
Annunciator blink register 2	IP21	IP20	IB25	IB24	IB23	IB22	IB21	IB20
Annunciator blink register 3	IP31	IP30	IB35	IB34	IB33	IB32	IB31	IB30

IPn1	IPn0	Blink Block
0	0	Block 0 (SEG1–SEG6)
0	1	Block 1 (SEG7–SEG12)
1	0	Block 2 (SEG13–SEG18)
1	1	Block 3 (SEG19–SEG24)

IPn1, IPn0: Block select bits (n = 1, 2, 3)

**Figure 18 Annunciator Blink Registers**

Discontinued

**Power Down Modes**

The HD66410 has a standby function providing low power-dissipation, which is initiated by internal register settings. There are two standby modes: in one, all the HD66410 functions are inactive, and in the other, only the annunciator display function is active. In both modes, the internal booster halts but data in the display RAM and internal registers except the DISP bit is retained. However, only control registers can be accessed during standby modes. In the standby mode with annunciator display, the oscillator does not halt, thus dissipating more power than in the other standby mode. Table 1 lists the LCD driver output pin status during standby modes. Figure 19 shows the procedure for initiating and canceling a standby mode. Note that the cancelation procedure must be strictly followed to protect data in the display RAM.

**Table 1 Output Pin Status during Standby Modes**

X1 to X161	Output V <sub>cc</sub> (display off)	
COM1 to COM3	OSC = 0	Output V <sub>cc</sub> (display off)
	OSC = 1	Output common signals (display on)
SEG1 to SEG24	OSC = 0	Output V <sub>cc</sub> (display off)
	OSC = 1	Output segment signals (display on)

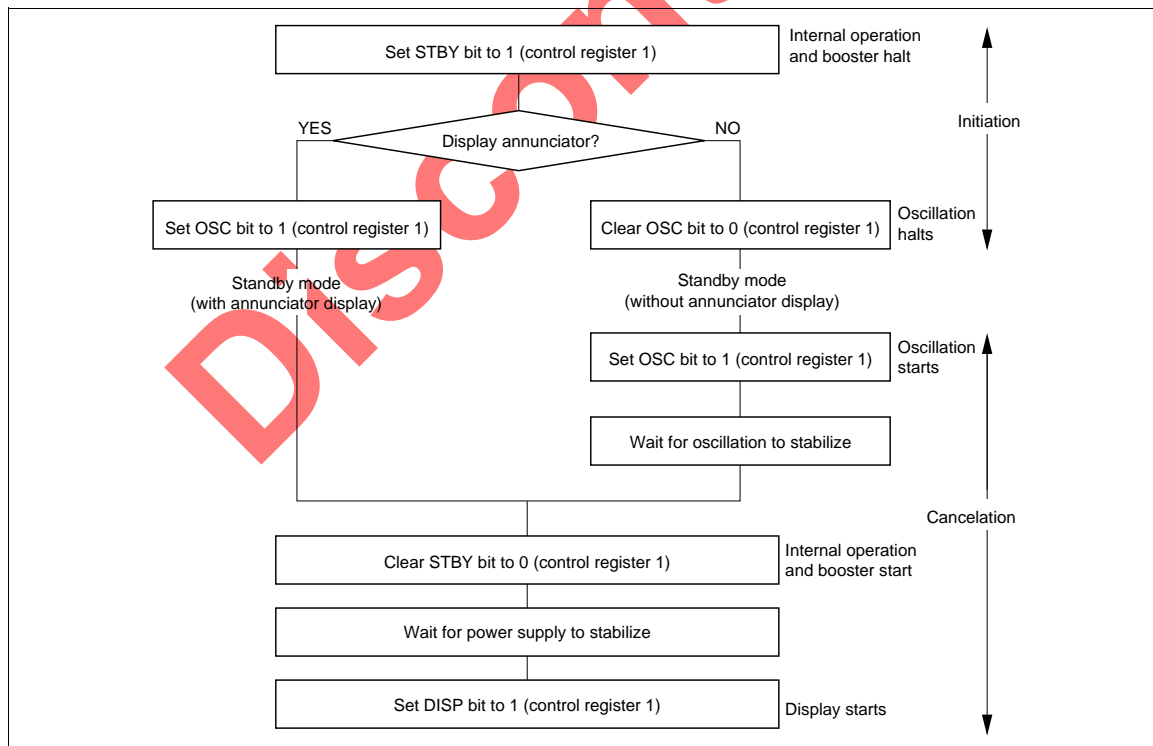

**Figure 19 Procedure for Initiating and Canceling a Standby Mode**

---

## HD66410

---

### Power On/Off Procedure

Figure 20 shows the procedure for turning the power supply on and off. This procedure must be strictly followed to prevent incorrect display because the HD66410 incorporates all power supply circuits .

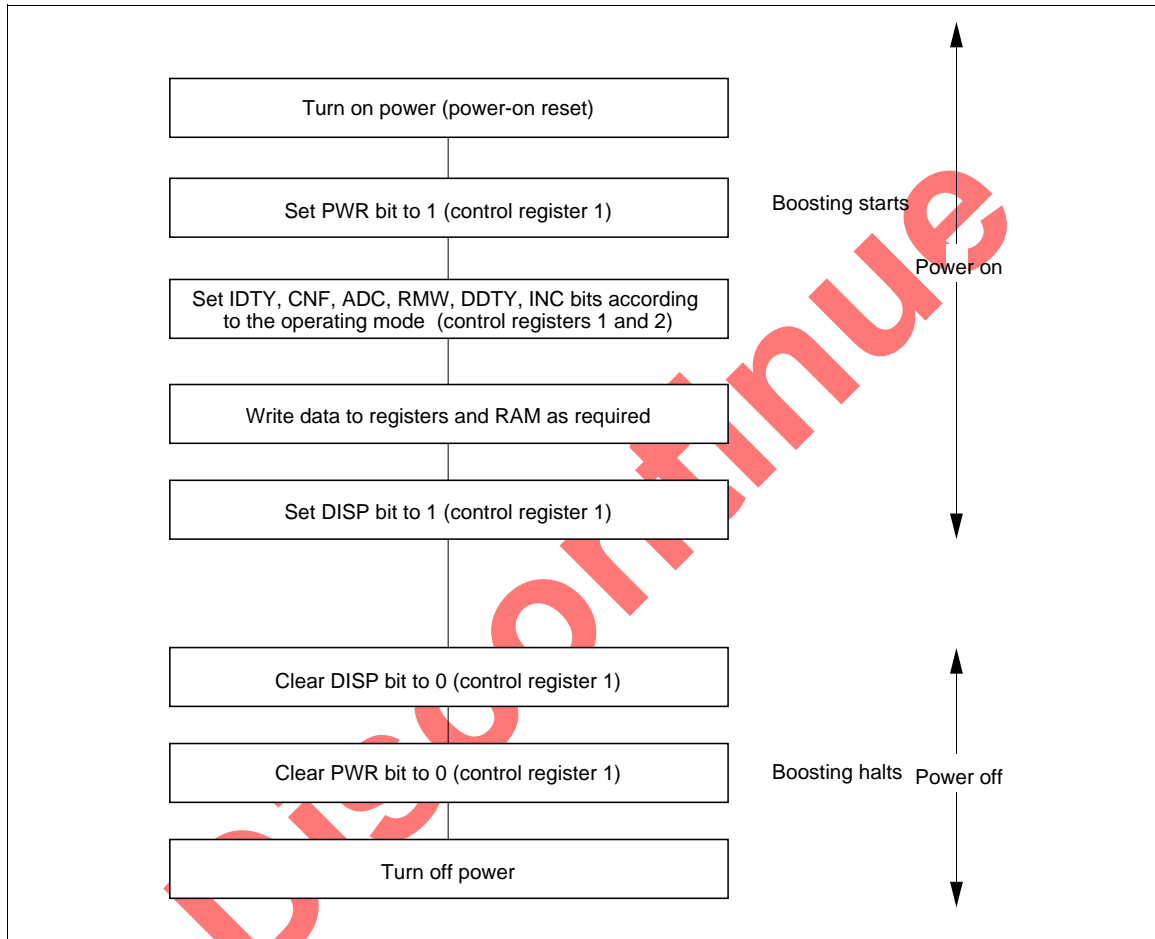

**Figure 20 Procedure for Turning Power Supply On/Off**

**Annunciator Display Function**

The HD66410 can display up to 72 dots of annunciator using 24 segment (column) drivers (SEG1 to SEG24) and three common (row) drivers (COM1 to COM3). These drivers, independent of the display RAM, operate statically or with a 1/3 duty cycle. They are available even during standby modes, where dot-matrix display and the internal booster is turned off, making them suitable for time and other mark indications with reduced power dissipation.

The dots to be displayed are designated by annunciator display data registers 1 to 9. For static drive, only display data registers 1, 3, and 7 and row driver COM1 are used. A maximum of 18 turned-on dots can be blinked. For details on blinking, see the Blink Function section. Figure 21 shows the relationship between annunciator display data register bits and display positions. In the figure, alphanumeric in the ovals indicate the bit names of annunciator display data registers. Data value 1 turns on the corresponding dot on the panel, and data value 0 turns off the corresponding dot. Table 2 lists the annunciator display data registers.

**Table 2 Annunciator Display Data Register Bits**

Register		DB7	DB6	DB5	DB4	DB3	DB2	DB1	DB0
Annunciator display data register 1	A0	IC1A	IC1B	IC1C	IC1D	IC1E	IC1F	IC1G	IC1H
Annunciator display data register 2	A1	IC2A	IC2B	IC2C	IC2D	IC2E	IC2F	IC2G	IC2H
Annunciator display data register 3	A2	IC3A	IC3B	IC3C	IC3D	IC3E	IC3F	IC3G	IC3H
Annunciator display data register 4	A3	IC1I	IC1J	IC1K	IC1L	IC1M	IC1N	IC1O	IC1P
Annunciator display data register 5	A4	IC2I	IC2J	IC2K	IC2L	IC2M	IC2N	IC2O	IC2P
Annunciator display data register 6	A5	IC3I	IC3J	IC3K	IC3L	IC3M	IC3N	IC3O	IC3P
Annunciator display data register 7	A6	IC1Q	IC1R	IC1S	IC1T	IC1U	IC1V	IC1W	IC1X
Annunciator display data register 8	A7	IC2Q	IC2R	IC2S	IC2T	IC2U	IC2V	IC2W	IC2X
Annunciator display data register 9	A8	IC3Q	IC3R	IC3S	IC3T	IC3U	IC3V	IC3W	IC3X

Note: Only annunciator display data registers 1, 3, and 7 are used for static display.

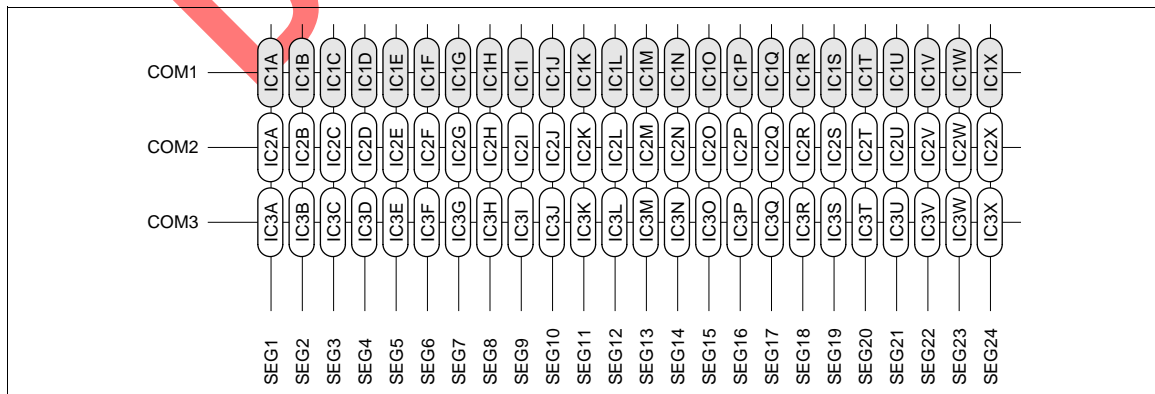

**Figure 21 Annunciator Display Data and Display Positions**

---

## HD66410

---

### Oscillator

The HD66410 incorporates an R-C oscillator with low power-dissipation, in which the oscillation frequency can be adjusted by appropriate selection of oscillator resistor  $R_f$  and capacitor  $C_f$ . The adjusted clock signal is used for system internal circuits; thus, if this oscillator is not used, an appropriate clock signal must be externally input through the CR pin. In this case, the C and R pins must be left unconnected. Figure 22 shows oscillator connections.

### Clock and Frame Frequency

The HD66410 generates the frame frequency (LCD drive frequency) by dividing the input clock frequency by 132. The division ratio is the same for all LCD duty cycles.

The frame frequency is usually 70 to 90 Hz; when the frame frequency is 80 Hz, for example, the input clock frequency must be 10.56 kHz.

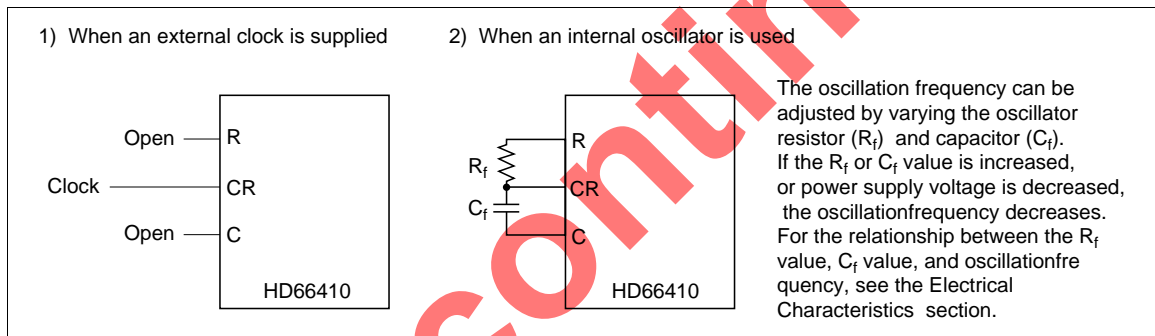
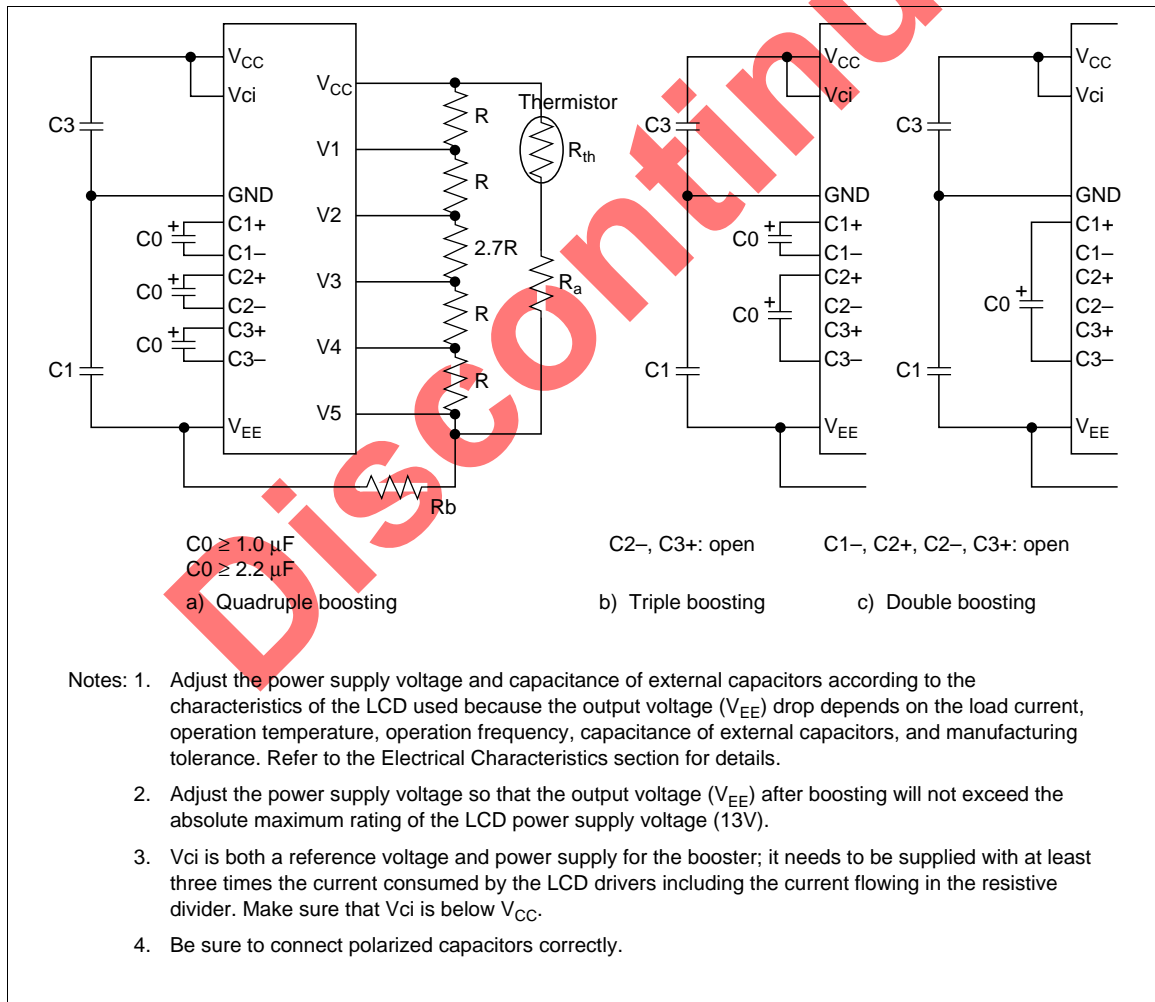

Figure 22 Oscillator Connections

**Power Supply Circuits**

The HD66410 incorporates a double to quadruple booster to supply power to LCD drivers. The booster is automatically turned off during standby mode, dissipating no power. If the current capacity provided is insufficient for the user system, external power supply circuits are necessary. In this case, the internal power supply can be turned off by register settings. Figure 23 shows examples of power supply circuits for different boosting ratios.

**Booster:** The internal booster raises the input voltage between  $V_{CC}$  and GND two to four times every raster by turning on the internal power supply with capacitors attached between C1+ and C1-, C2+ and C2-, C3+ and C3-, and to  $V_{EE}$ . The booster uses the system clock, and thus the internal oscillator must be operating to activate the booster (if the internal oscillator has been selected to generate the system clock).  $V_{EE}$  outputs  $V_{CC}$  level when the booster is inactive.



**Figure 23 Power Supply Circuit Examples**

---

## HD66410

---

**LCD Drive Voltage Power Supply Levels:** To drive the LCD, a 6-level power supply is necessary. These levels can be usually generated by dividing the  $V_{CC}$ -V5 power supply using resistive dividers. If the total resistance is small, current consumption increases, and if the total resistance is large, display quality degrades. Appropriate resistance should be selected for the user system.

**Brightness Adjust:** The booster drives liquid crystals with a voltage after raising the voltage supplied to the Vci pin two to four times. Accordingly, brightness can be adjusted by varying the Vci level. Attaching a thermister is recommended to vary the voltage according to the thermal characteristics of liquid crystals.

**Annunciator:** Annunciator has its own power circuit apart from the main power circuit. Four power supply levels are used: these are  $V_{CC}$ , AV3 and two levels generated by dividing the  $V_{CC}$ -AV3 power supply using internal resistive dividers. The level of AV3 must be inside of  $V_{CC}$ -GND power supply or connected to GND unless bright adjust is used. Brightness of annunciator can be adjusted by inserting a resistor into between AV3 and GND. The value of this resistor might be several hundred kilo-ohm because the value of internal resistor is around one mega-ohm. Figure 24 shows the power circuit for annunciator.

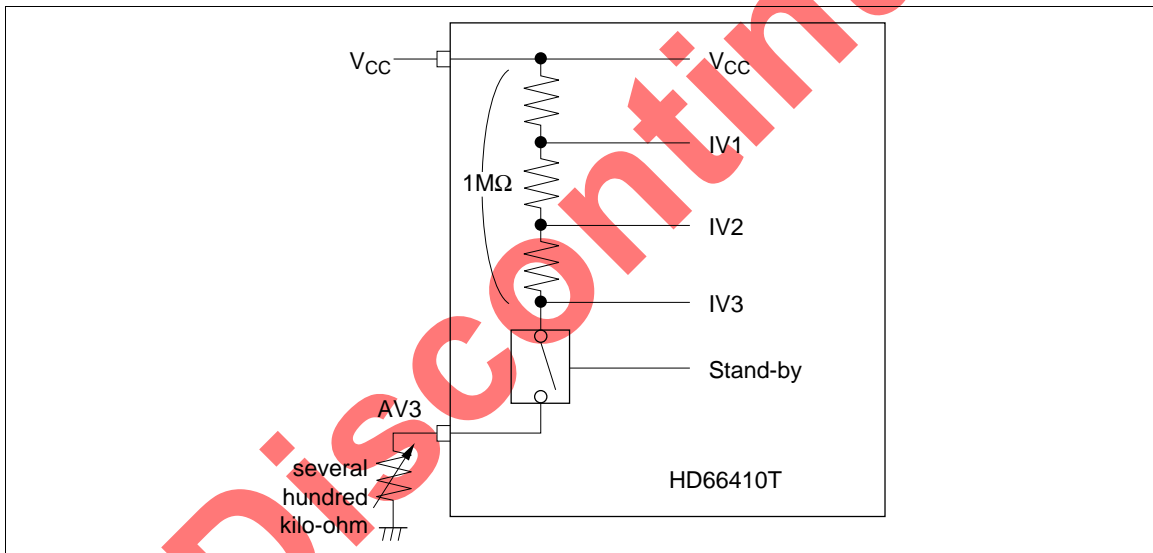

Figure 24 Power Circuit for Annunciator

**Row/Column Output Switchover:** LCD column drivers use  $V_{CC}$ , V2, V3, and V5, while row drivers use  $V_{CC}$ , V1, V4, and V5. These voltage levels are switched to AC and are output to an LCD panel. Since the HD66410 can assign X1 to X16 and X129 to X144 to either row or column output, the power supply connection must be externally changed according to the assignment, which is determined by the CNF bit value in control register 1. The select and deselect levels for row output are temporarily output from the VCHO and VCLO pins, and the two levels for column output are output from the VSHO and VSLO pins; these outputs must be connected according to row and column output assignment as shown in Figure 25.

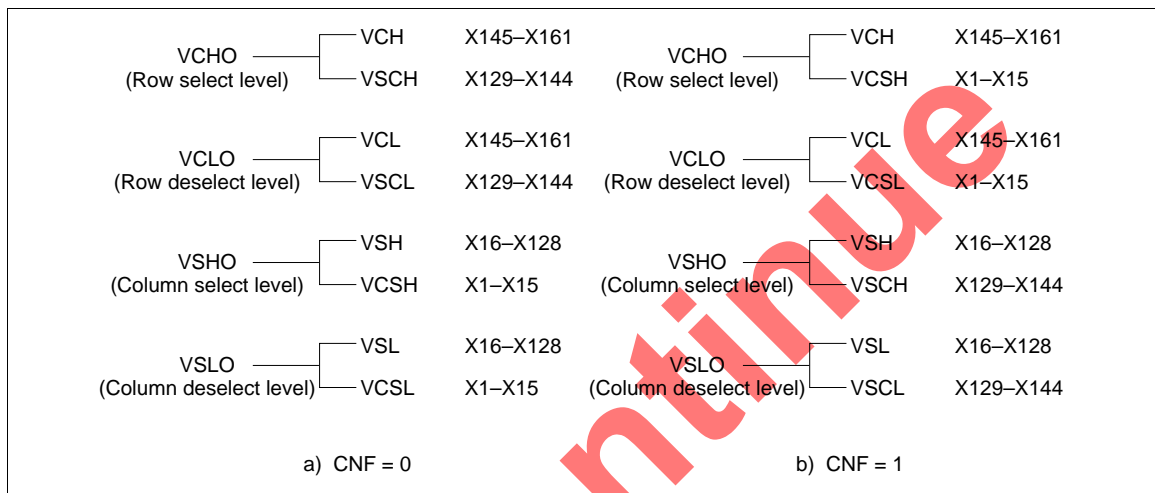

Figure 25 Connection of LCD Drive Voltage Level Pins

---

## HD66410

---

### Reset

The low  $\overline{\text{RESET}}$  signal initializes the HD66410, clearing all the bits in the internal registers. During reset, the internal registers cannot be accessed.

Note that if the reset conditions specified in the Electric Characteristics section are not satisfied, the HD66410 will not be correctly initialized. In this case, the internal registers of the HD66410 must be initialized by software.

**Initial Setting of Internal Registers:** All the internal register bits are cleared to 0. Details are listed below.

- The data in index register is not affected
- The data in the internal RAM are not affected
- All counters are cleared to zero
- Modes after reset
  - Normal operation
  - Oscillator is active
  - Display is off (including annunciator display)
  - Booster is not used
  - Y address of display RAM is incremented
  - 1/33 duty cycle
  - X and Y addresses are 0
  - Data in address H'0 is output from the X1 pin
  - Blink function is inactive

### Initial Setting of Pins:

- Bus interface pins  
During reset, the bus interface pins do not accept signals to access internal registers; data is undefined when read.
- LCD driver output pins  
During reset, all the LCD driver output pins (X1 to X161, SEG1 to SEG33, COM1 to COM3) output  $V_{CC}$ -level voltage, regardless of data value in the display RAM, turning off the LCD. Here, the output voltage is not alternated. Note that the same voltage ( $V_{CC}$ ) is applied to both column and row output pins to prevent liquid crystals from degrading.
- Booster output pins  
Since the PWR bit in control register 1 is 0 during reset, the booster halts. Accordingly, the output state of the  $V_{EE}$  pin depends on the value of the booster's external capacitor.

## Internal Registers

The HD66410 has one index register and 22 data registers, all of which can be accessed asynchronously with the internal clock. All the registers except the display memory access register are write-only. Accessing unused bits or addresses affects nothing; unused bits should be set to 0 when written to.

**Index Register (IR):** The index register (Figure 26) selects one of 22 data registers. The index register itself is selected when both the  $\overline{CS}$  and RS signals are low. Data bits 7 to 5 are unused; they should be set to 0 when written to.

**Control Register 1 (R0):** Control register 1 (Figure 27) controls general operations of the HD66410. Each bit has its own function as described below. Data bit 7 bit is unused; it should be set to 0 when written to.

- DSP bit  
DSP = 1: Display on  
DSP = 0: Display off (all LCD driver output pins output  $V_{CC}$  level)
- STBY bit  
STBY = 1: Internal operation and booster halt; display off  
STBY = 0: Normal operation  
The STBY bit does not affect the state of PWR and DISP bit.
- PWR bit  
PWR = 1: Booster active  
PWR = 0: Booster inactive
- OSC bit  
OSC = 1: Internal operation and booster halt; oscillator does not halt to provide annunciator display  
OSC = 0: Internal operation, booster, and oscillator halt  
The OSC bit is valid only when the STBY bit is 1.
- IDTY bit  
IDTY = 1: Annunciator display signals are operating statically  
IDTY = 0: Annunciator display signals are operating with 1/3 duty cycle
- CNF bit  
CNF = 1: Row output on both sides of the LCD panel  
CNF = 0: Row output on one side of the LCD panel
- ADC bit  
ADC = 1: Data in X address H'0 is output from X128 or X144; row signals are scanned from X129 to X161.  
ADC = 0: Data in X address H'0 is output from X1 or X17; row signals are scanned from X161 to X129.

---

**HD66410**

---

IR	Data bit	7	6	5	4	3	2	1	0
	Set value				Register number				

**Figure 26 Index Register (IR)**

R0	Data bit	7	6	5	4	3	2	1	0
	Set value		DISP	STBY	PWR	OSC	IDTY	CNF	ADC

**Figure 27 Control Register 1 (R0)**

Discontinue

**Control Register 2 (R1):** Control register 2 (Figure 28) controls general operations of the HD66410. Each bit has its own function as described below. Data bits 7 to 4 are unused; they should be set to 0 when written to.

- **RMW bit**
  - RMW = 1: Read-modify-write mode  
Address is incremented only after write access
  - RMW = 0: Address is incremented after both write and read accesses
- **DDTY bit**
  - DDTY = 1: 1/17 display duty cycle
  - DDTY = 0: 1/33 display duty cycle
- **INC bit**
  - INC = 1: X address is incremented for each access
  - INC = 0: Y address is incremented for each access
- **BLK bit**
  - BLK = 1: Blink function is used
  - BLK = 0: Blink function is not used
  - The blink counter is reset when the BLK bit is set to 0. It starts counting and at the same time initiates blinking when the BLK bit is set to 1.

**X Address Register (R2):** The X address register (Figure 29) designates the X address of the display RAM to be accessed by the MPU. The set value must range from H'0 to H'F; setting a greater value is ignored. The set address is automatically incremented each time the display RAM is accessed; it is not necessary to update the address each time. Data bits 7 to 4 are unused; they should be set to 0 when written to.

**Y Address Register (R3):** The Y address register (Figure 30) designates the Y address of the display RAM to be accessed by the MPU. The set value must range from H'00 to H'20; setting a greater value is ignored. The set address is automatically incremented each time the display RAM is accessed; it is not necessary to update the address each time. Data bit 7 is unused; it should be set to 0 when written to.

---

**HD66410**

---

R1	Data bit	7	6	5	4	3	2	1	0
	Set value					RMW	DDTY	INC	BLK

**Figure 28 Control Register 2 (R1)**

R2	Data bit	7	6	5	4	3	2	1	0
	Set value					XA3	XA2	XA1	XA0

**Figure 29 X Address Register (R2)**

R3	Data bit	7	6	5	4	3	2	1	0
	Set value			YA5	YA4	YA3	YA2	YA1	YA0

**Figure 30 Y Address Register (R3)**

Discontinued

**Display Memory Access Register (R4):** The display memory access register (Figure 31) is used to access the display RAM. If this register is write-accessed, data is directly written to the display RAM. If this register is read-accessed, data is first latched to this register from the display RAM and sent out to the data bus on the next read; therefore, a dummy read access is necessary after setting the display RAM address.

**Display Start Raster Register (R5):** The display start raster register (Figure 32) designates the raster to be displayed at the top of the LCD panel. Varying the set value scrolls the display vertically. The set value must be one less than the actual top raster and range from 0 to 32 for 1/33 duty cycle and from 0 to 16 for 1/17 duty cycle. If the value is set outside these ranges, data may not be displayed correctly. Data bits 7 and 6 are unused; they should be set to 0 when written to.

**Blink Registers (R6, R7):** The blink bit registers (Figure 33) designate the 8-bit groups to be blinked. Setting a bit to 1 blinks the corresponding 8-bit group. Any number of groups can be blinked; setting all the bits to 1 will blink the entire LCD panel. These bits are valid only when the BLK bit of control register 2 is 1.

R4	Data bit	7	6	5	4	3	2	1	0
	Set value	D7	D6	D5	D4	D3	D2	D1	D0

**Figure 31 Display Memory Access Register (R4)**

R5	Data bit	7	6	5	4	3	2	1	0
	Set value			ST5	ST4	ST3	ST2	ST1	ST0

**Figure 32 Display Start Raster Register (R5)**

R6	Data bit	7	6	5	4	3	2	1	0
	Set value	BK0	BK1	BK2	BK3	BK4	BK5	BK6	BK7
R7	Set value	BK8	BK9	BK10	BK11	BK12	BK13	BK14	BK15

**Figure 33 Blink Registers (R6, R7)**

---

## HD66410

---

**Blink Start Raster Register (R8):** The blink start raster register (Figure 34) designates the top raster in the area to be blinked. The set value must be one less than the actual top raster and range from 0 to 32 for 1/33 duty cycle and from 0 to 16 for 1/17 duty cycle. If the value is set outside these ranges, operations may not be correct. Data bits 7 and 6 are unused; they should be set to 0 when written to.

**Blink End Raster Register (R9):** The blink end raster register (Figure 35) designates the bottom raster in the area to be blinked. The area to be blinked is designated by the blink registers, blink start raster register, and blink end raster register. The set value must be one less than the actual bottom raster and range from 0 to 32 for 1/33 duty cycle and from 0 to 16 for 1/17 duty cycle. It must also be greater than the value set in the blink start raster register. If an inappropriate value is set, operations may not be correct. Data bits 7 and 6 are unused; they should be set to 0 when written to.

R8	Data bit	7	6	5	4	3	2	1	0
	Set value			BSL5	BSL4	BSL3	BSL2	BSL1	BSL0

Figure 34 Blink Start Raster Register (R8)

R9	Data bit	7	6	5	4	3	2	1	0
	Set value			BEL5	BEL4	BEL3	BEL2	BEL1	BEL0

Figure 35 Blink End Raster Register (R9)

**Annunciator Display Data Registers (A0 to A8):** The annunciator display data registers (Figure 36) store data for annunciator (icon) display. Setting a data bit to 1 turns on the corresponding dot on the LCD panel.

**Annunciator Blink Registers (A9 to A11):** The annunciator blink registers (Figure 37) designate bits to be blinked on the annunciator display. For details, see the Blink Function section.

- IPn1, IPn0 bits (n = 1, 2, 3)  
 These bits select annunciator blocks to be blinked.  
 IPn1, IPn0 = 0, 0: Block 0 is selected (SEG1 to SEG6)  
 IPn1, IPn0 = 0, 1: Block 1 is selected (SEG7 to SEG12)  
 IPn1, IPn0 = 1, 0: Block 2 is selected (SEG13 to SEG18)  
 IPn1, IPn0 = 1, 1: Block 3 is selected (SEG19 to SEG24)
- IBn5, IBn0 bits (n = 1, 2, 3)  
 These bits select bits to be blinked in the selected blocks.

	Data bit	7	6	5	4	3	2	1	0
A0	Set value	IC1A	IC1B	IC1C	IC1D	IC1E	IC1F	IC1G	IC1H
A1	Set value	IC2A	IC2B	IC2C	IC2D	IC2E	IC2F	IC2G	IC2H
A2	Set value	IC3A	IC3B	IC3C	IC3D	IC3E	IC3F	IC3G	IC3H
A3	Set value	IC1I	IC1J	IC1K	IC1L	IC1M	IC1N	IC1O	IC1P
A4	Set value	IC2I	IC2J	IC2K	IC2L	IC2M	IC2N	IC2O	IC2P
A5	Set value	IC3I	IC3J	IC3K	IC3L	IC3M	IC3N	IC3O	IC3P
A6	Set value	IC1Q	IC1R	IC1S	IC1T	IC1U	IC1V	IC1W	IC1X
A7	Set value	IC2Q	IC2R	IC2S	IC2T	IC2U	IC2V	IC2W	IC2X
A8	Set value	IC3Q	IC3R	IC3S	IC3T	IC3U	IC3V	IC3W	IC3X

**Figure 36 Annunciator Display Data Registers (A0 to A8)**

	Data bit	7	6	5	4	3	2	1	0
A9	Set value	IP11	IP10	IB15	IB14	IB13	IB12	IB11	IB10
A10	Set value	IP21	IP20	IB25	IB24	IB23	IB22	IB21	IB20
A11	Set value	IP31	IP30	IB35	IB34	IB33	IB32	IB31	IB30

**Figure 37 Annunciator Blink Registers (A9 to A11)**

---

## HD66410

---

### Absolute Maximum Ratings

Item		Symbol	Ratings	Unit	Notes
Power supply voltage	Logic circuit	$V_{CC}$	-0.3 to +7.0	V	1
	LCD drive circuits	$V_{EE}$	$V_{CC} - 18.0$ to $V_{CC} + 0.3$	V	
Input voltage 1		VT1	-0.3 to $V_{CC} + 0.3$	V	1, 2
Input voltage 2		VT2	$V_5 - 0.3$ to $V_{CC} + 0.3$	V	1, 3
Operating temperature		$T_{opr}$	-30 to +75	°C	
Storage temperature		$T_{stg}$	-55 to +110	°C	

Notes: 1. Measured relative to GND.

2. Applies to pins CR, DB7 to DB0,  $\overline{RD}$ ,  $\overline{WR}$ ,  $\overline{CS}$ , RS,  $\overline{RES}$ , TEST0.

3. Applies to pins V1, V2, V3, V4, V5, VSH, VSL, VCH, VCL, VSCH, VSCL, VCSH, VCSL.

4. If the LSI is used beyond its absolute maximum rating, it may be permanently damaged. It should always be used within the limits of its electrical characteristics to prevent malfunction or unreliability.

Discontinued

**Electrical Characteristics**

**DC Characteristics ( $V_{CC} = 2.2$  to  $5.5V$ ,  $GND = 0V$ ,  $V_{CC}-V5 = 6$  to  $15V$ ,  $T_a = -30$  to  $+75^{\circ}C$ )\*8**

Item	Symbol	Applicable Pins	Min	Typ	Max	Unit	Measurement Condition	Notes
Input leakage current (1)	$I_{IL1}$		-1	—	1	$\mu A$	$V_{in} = V_{CC}$ to GND	1
Input leakage current (2)	$I_{IL2}$		-10	—	10	$\mu A$	$V_{in} = V_{CC}$ to V5	2
Driver "on" resistance	$R_{ON}$	X1 to X161			20	$k\Omega$	$I_{ON} = 100 \mu A$ $V_{CC}-V5 = 8V$	3
Input high voltage	$V_{IH1}$		$0.8 \times V_{CC}$	—	$V_{CC}$	V		1
Input low voltage	$V_{IL1}$		0	—	$0.2 \times V_{CC}$	V		1
Output high voltage	$V_{OH}$	DB7 to DB0	$0.8 \times V_{CC}$	—	$V_{CC}$	V	$I_{OH} = -50 \mu A$	
Output low voltage	$V_{OL}$	DB7 to DB0	0	—	$0.2 \times V_{CC}$	V	$I_{OL} = 50 \mu A$	
Current consumption during display	$I_{disp}$		—	55	80	$\mu A$		4, 5
Current consumption during annunciator display	$I_{ann}$		—	17	30	$\mu A$		4, 6
Current consumption during standby	$I_{stb}$		—	0.1	5	$\mu A$		4, 7

- Notes:
- Applies to pins: CS, RS, WR, RD, RES, CR, TEST0, DB7 to DB0
  - Applies to pins: V1, V2, V3, V4, VCH, VCL, VSH, VSL, VCSH, VCSL, VSCH, VSCL
  - Indicates the resistance between one pin from X1 to X161 and another pin from V1, V2, V3 and V4. VCHO, VCLO, VSHO, VSLO and VCH, VCL, VSH, VSL, VCSH, VCSL, VSCH, VSCL are connected according to the configuration. V1 and V2 should be near  $V_{CC}$  level, and V3 and V4 should be near V5 level. All voltage must be within  $\Delta V$ .  $\Delta V$  is the range within which  $R_{ON}$  is stable. V1 to V4 levels should keep following condition:  $V_{CC} \geq V1 \geq V2 \geq V3 \geq V4 \geq V5$
  - Input and output current are excluded. When a CMOS input is floating, excess current flows from power supply to the input circuit. To avoid this,  $V_{IH}$  and  $V_{IL}$  must be held to  $V_{CC}$  and GND levels, respectively. The current which flows at resistive divider and LCD are excluded. When the unmolded side of LSI is exposed to light, excess current flows. Use under sealed condition.
  - Specified under following conditions:  
Internal oscillator is used;  $R_f = 470 k\Omega$ ,  $C_f = 100 pF$   
Triple boosting is used;  $C_0 = 1.0 \mu F$ ,  $C_1 = 2.2 \mu F$   
 $V_{CC} = V_{ci} = 3.0V$ ,  $V_5 = V_{EE}$ ,  $AV3 = GND$ ,  $T_a = 25^{\circ}C$   
Checker board is displayed  
No access from MPU
  - Measured when STB bit is 1 and OSC bit is 1.  
Internal oscillator is used;  $R_f = 470 k\Omega$ ,  $C_f = 100 pF$   
 $V_{CC} = 3.0V$ ,  $AV3 = GND$
  - Measured when STB bit is 1 and OSC bit is 0.  $V_{CC} = 3.0V$ , All LCD driving outputs, X1 to X161, output  $V_{CC}$  level, so no current is consumed at the resistive divider.
  - Specified at  $+75^{\circ}C$  for die products.

## HD66410

**Booster Characteristics** ( $V_{CC} = 2.2$  to  $5.5V$ ,  $GND = 0V$ ,  $V_{CC}-V5 = 6$  to  $15V$ ,  $T_a = -30$  to  $+75^\circ C$ )<sup>\*3</sup>

Item	Symbol	Min.	Typ	Max	Unit	Measurement Condition	Notes
Output voltage	$V_{EE}$	10	11	12	V		1
Input voltage	$V_{ci}$	—	—	3.6	V		2

Notes: 1. Measured when  $V_{CC} = V_{ci} = 3.0V$ ,  $I_o$  (load current) =  $0.25$  mA,  $C_0 = 1$   $\mu F$ ,  $C_1 = 2.2$   $\mu F$   
 $f_{osc}$  (oscillation frequency) =  $10$  kHz, and the input voltage is boosted four times.  
 2. Input voltage must be below  $V_{CC}$ .  
 3. Specified at  $+75^\circ C$  for die products.

### Current Consumption

Current consumption are shown below under various conditions. These values are shown as a reference, and are not guaranteed.

#### Current Consumption during Display 1

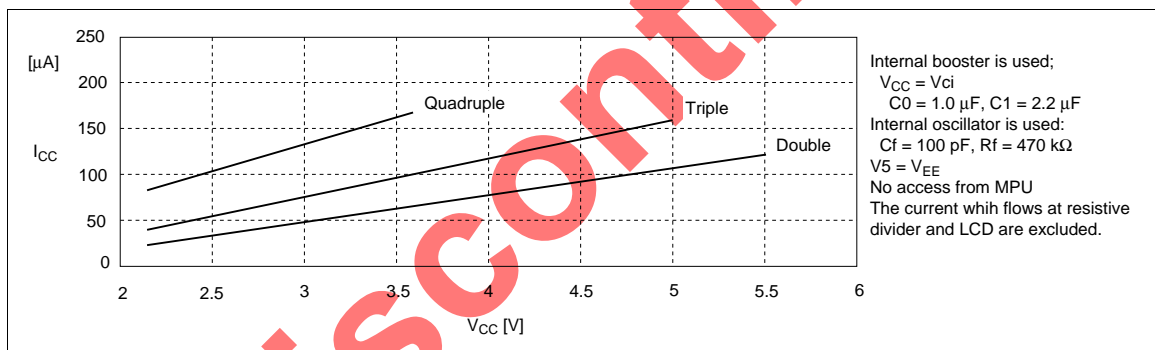

#### Current Consumption during Display 2

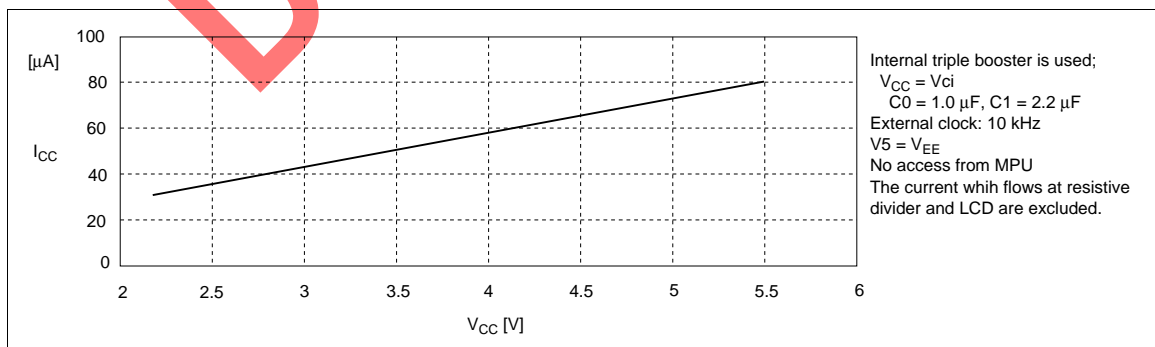

**Current Consumption during Display 3**

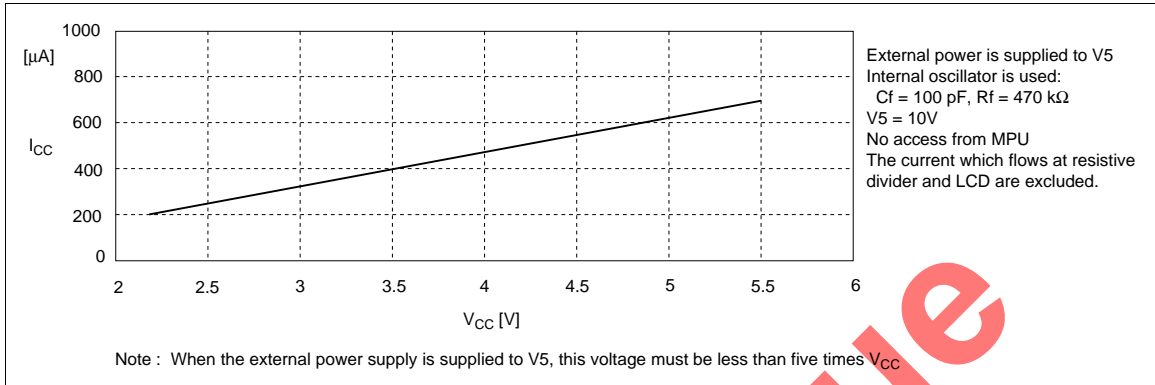

**Current Consumption during being accessed form MPU**

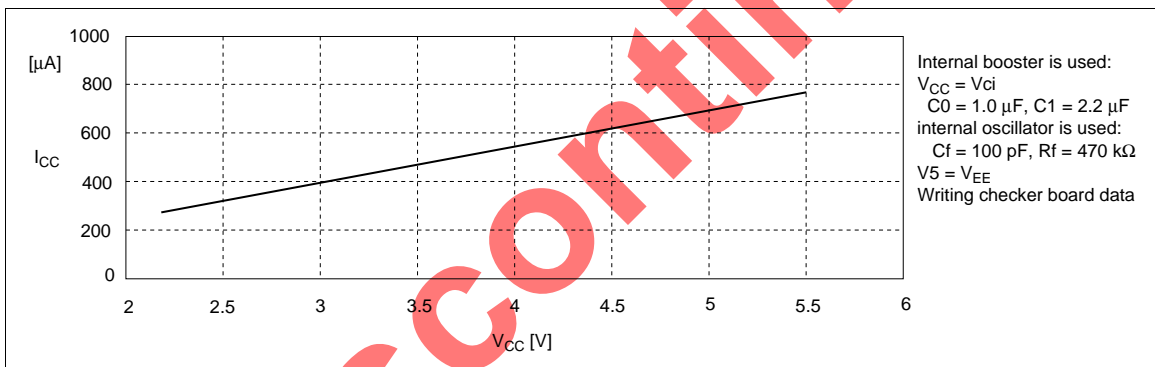

**Oscillation Frequency**

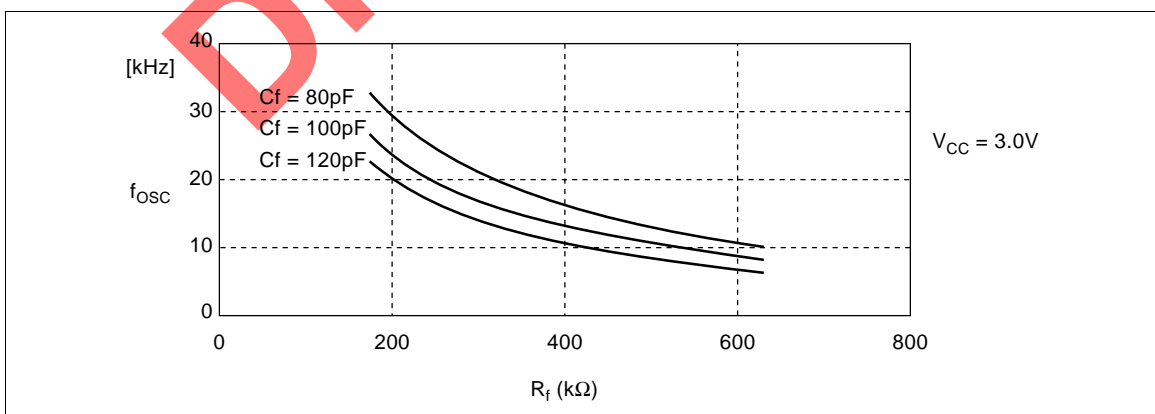

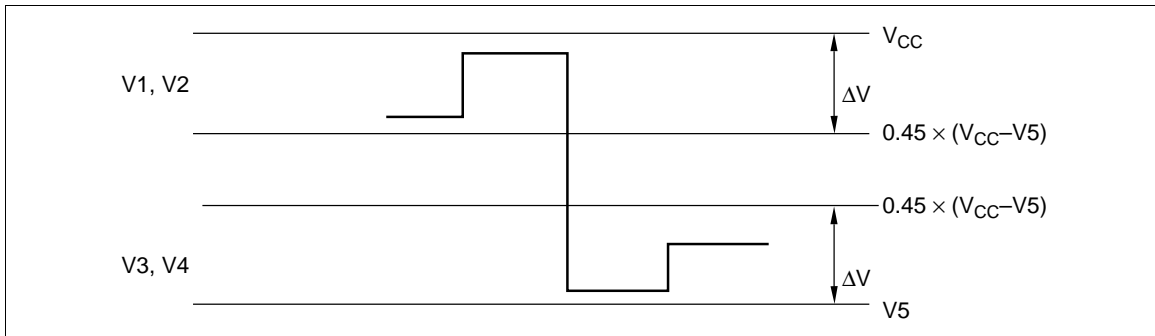

**Figure 38 Limitation of V1 to V4 Levels**

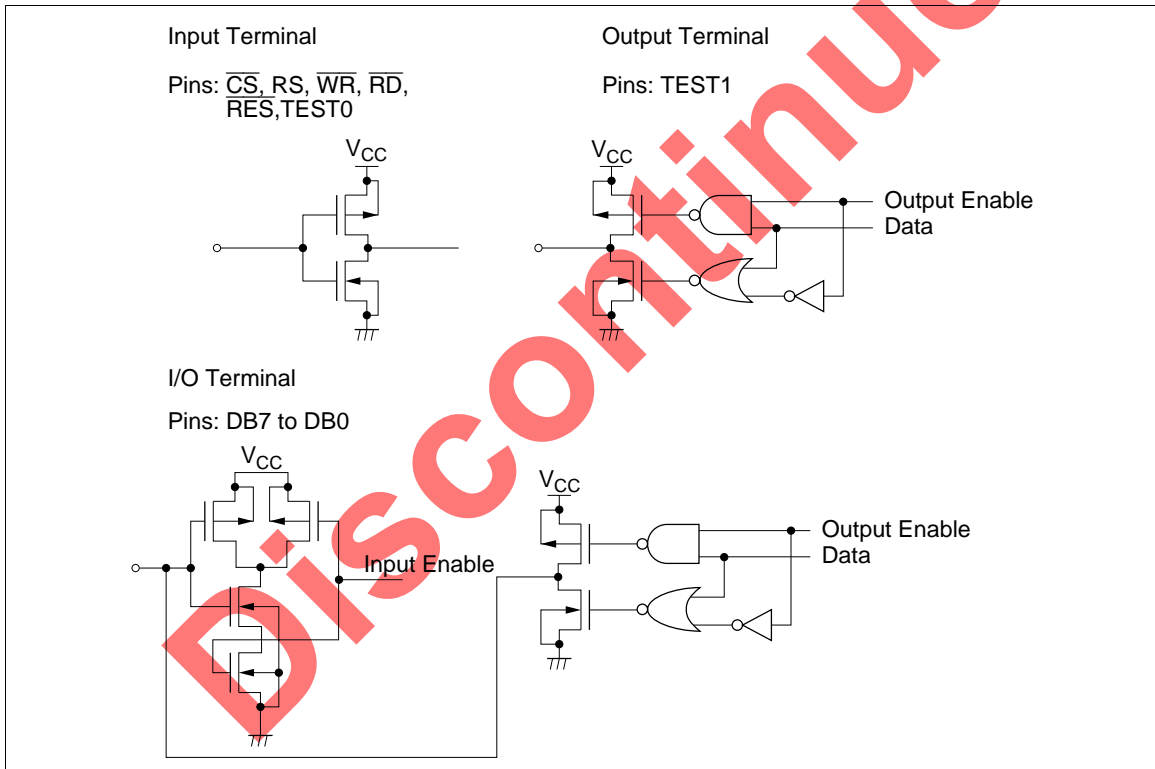

**Figure 39 Terminal Configuration**

**AC Characteristics 1 ( $V_{CC} = 2.2$  to  $4.5V$ ,  $GND = 0V$ ,  $T_a = -30$  to  $+75^\circ C$ )\*<sup>3</sup>**

**Clock Characteristics**

Item	Symbol	Min	Typ	Max	Unit	Notes
Oscillation frequency	$f_{OSC}$	7	10	13	kHz	$C_f = 100$ pF, $R_f = 470$ k $\Omega$
External clock frequency	$f_{CP}$	7	10	20	kHz	
External clock duty cycle	Duty	45	50	55	%	
External clock fall time	$t_f$	—	—	0.2	$\mu S$	
External clock rise time	$t_r$	—	—	0.2	$\mu S$	

**MPU Interface**

Item	Symbol	Min	Typ	Max	Unit	Notes
$\overline{RD}$ low-level width	$t_{WRDL}$	450	—	$t_{cyc}/2-450$	ns	1, 2
$\overline{RD}$ high-level width	$t_{WRDH}$	450	—	—	ns	1
$\overline{WR}$ low-level width	$t_{WWRL}$	450	—	$t_{cyc}/2-450$	ns	1, 2
$\overline{WR}$ high-level width	$t_{WWRH}$	450	—	—	ns	1
Address setup time	$t_{AS}$	10	—	—	ns	
Address hold time	$t_{AH}$	10	—	—	ns	
Data delay time	$t_{DDR}$	—	—	360	ns	
Data output hold time	$t_{DHR}$	10	—	—	ns	
Data setup time	$t_{DSW}$	150	—	—	ns	
Data hold time	$t_{DHW}$	10	—	—	ns	

**MPU Interface**

Item	Symbol	Min	Typ	Max	Unit	Notes
$\overline{RES}$ low-level width	$t_{RES}$	1	—	—	ms	

- Notes
1.  $t_{cyc}$  is a period of the clock.
  2. Keep these specifications even if  $\overline{CS}$  is high. If these conditions are not kept, display flickering may happen.
  3. Specified at  $+75^\circ C$  for die products.

## HD66410

### AC Characteristics 2 ( $V_{CC} = 4.5V$ to $5.5V$ , $GND = 0V$ , $T_a = -30$ to $+75^\circ C$ )\*<sup>3</sup>

#### Clock Characteristics

Item	Symbol	Min	Typ	Max	Unit	Notes
Oscillation frequency	$f_{OSC}$	8	11.5	14	kHz	$C_f = 100$ pF, $R_f = 470$ k $\Omega$
External clock frequency	$f_{CP}$	7	—	20	kHz	
External clock duty cycle	Duty	45	50	55	%	
External clock fall time	$t_f$	—	—	0.2	$\mu$ S	
External clock rise time	$t_r$	—	—	0.2	$\mu$ S	

#### MPU Interface

Item	Symbol	Min	Typ	Max	Unit	Notes
$\overline{RD}$ low-level width	$t_{WRDL}$	450	—	$t_{cyc}/2-450$	ns	1, 2
$\overline{RD}$ high-level width	$t_{WRDH}$	450	—	—	ns	1
$\overline{WR}$ low-level width	$t_{WWRL}$	450	—	$t_{cyc}/2-450$	ns	1, 2
$\overline{WR}$ high-level width	$t_{WWRH}$	450	—	—	ns	1
Address setup time	$t_{AS}$	10	—	—	ns	
Address hold time	$t_{AH}$	10	—	—	ns	
Data delay time	$t_{DDR}$	—	—	360	ns	
Data output hold time	$t_{DHR}$	10	—	—	ns	
Data setup time	$t_{DSW}$	150	—	—	ns	
Data hold time	$t_{DHW}$	20	—	—	ns	

#### MPU Interface

Item	Symbol	Min	Typ	Max	Unit	Notes
$\overline{RES}$ low-level width	$t_{RES}$	1	—	—	ms	

- Notes
1.  $t_{cyc}$  is a period of the clock.
  2. Keep these specifications even if  $\overline{CS}$  is high. If these conditions are not kept, display flickering may happen.
  3. Specified at  $+75^\circ C$  for die products.

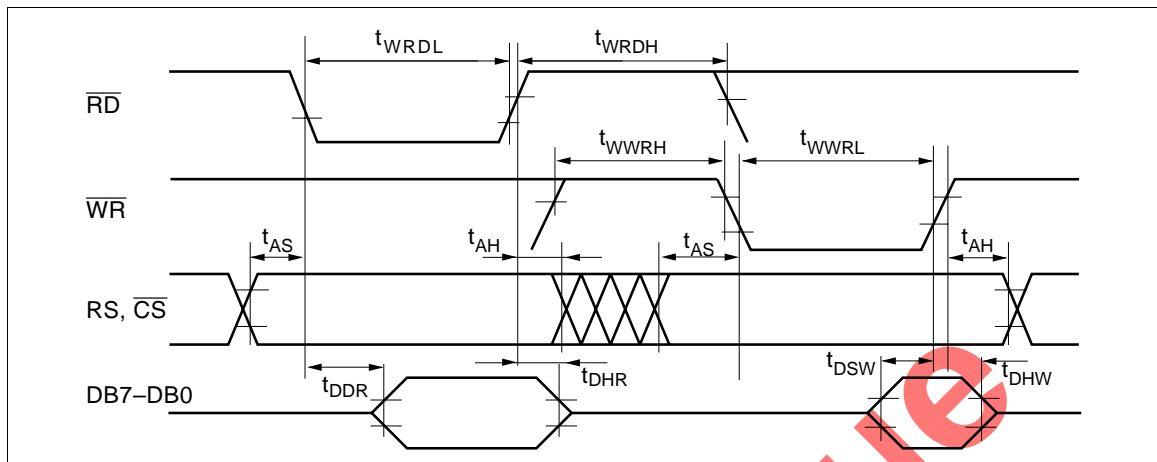

Figure 40 MPU Interface

Discontinued