

ECL 10KH High-Speed Emitter-Coupled Logic Family MC10H103 Quad 2-Input OR Gate

Features/Benefits

- Propagation delay, 1.0 ns typical
- Power dissipation 25 mW/gate
- Noise margin 150 mV
- Voltage compensated
- ECL 10K compatible

Ordering Information

PART NUMBER	PACKAGE	TEMPERATURE
MC10H103	J,N,NL(20)	Com

Description

The MC10H103 is a member of Monolithic Memories' ECL family. This ECL 10KH part is a functional/pinout duplication of the standard ECL 10K family part with 100% improvement in propagation delay, and no increase in power-supply current.

Logic Diagram

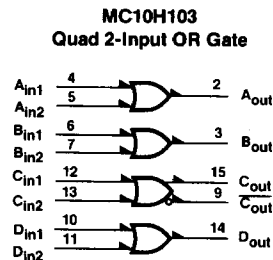

Pin Configurations

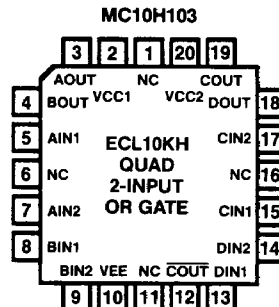
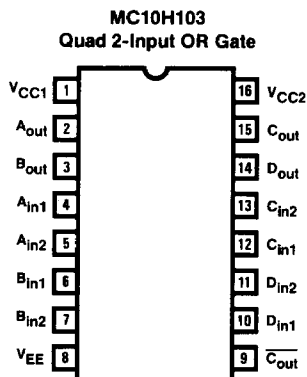

14

Portions of this Data Sheet reproduced with the courtesy of Motorola, Inc.

MC10H103

Absolute Maximum Ratings

Supply voltage V_{EE} ($V_{CC} = 0$)	-8.0 V to 0 V _{dc}
Input voltage V_I ($V_{CC} = 0$)	0 V _{dc} to V_{EE}
Output Current:	
Continuous	50 mA
Surge	100 mA

Operating Conditions

SYMBOL	PARAMETER	COMMERCIAL			UNIT
		MIN	TYP	MAX	
V_{EE}	Supply voltage	-5.46	-5.2	-4.94	V
T_A	Operating temperature range	0		75	°C
T_{STG}	Storage temperature range	Plastic		150	°C
		Ceramic		165	

Electrical Characteristics $V_{EE} = -5.2 \text{ V} \pm 5\%$ (See Note)

SYMBOL	PARAMETER	0°		25°		75°		UNIT
		MIN	MAX	MIN	MAX	MIN	MAX	
I_E	Power supply current	—	29	—	26	—	29	mA
I_{inH}	Input current HIGH	—	425	—	265	—	265	μA
I_{inL}	Input current LOW	0.5	—	0.5	—	0.3	—	μA
V_{OH}	HIGH output voltage	-1.02	-0.84	-0.98	-0.81	-0.92	-0.735	V _{dc}
V_{OL}	LOW output voltage	-1.95	-1.63	-1.95	-1.63	-1.95	-1.60	V _{dc}
V_{IH}	HIGH input voltage	-1.17	-0.84	-1.13	-0.81	-1.07	-0.735	V _{dc}
V_{IL}	LOW input voltage	-1.95	-1.48	-1.95	-1.48	-1.95	-1.45	V _{dc}

Switching Characteristics $V_{EE} = -5.2 \text{ V}, \pm 5\%$ (See Note)

SYMBOL	PARAMETER	0°		25°		75°		UNIT
		MIN	MAX	MIN	MAX	MIN	MAX	
t_{pd}	Propagation delay	0.4	1.3	0.4	1.3	0.4	1.45	ns
t_r, t_+	Rise time (20%-80%)	0.5	1.7	0.5	1.8	0.5	1.9	ns
t_f, t_-	Fall time (80%-20%)	0.5	1.7	0.5	1.8	0.5	1.9	ns

Note: Each ECL 10KH series circuit has been designed to meet the dc specifications shown in the test table, after thermal equilibrium has been established. The circuit is in a test socket or mounted on a printed circuit board and transverse air flow greater than 500 linear fpm is maintained. Outputs are terminated through a 50 Ω resistor to -2.0 V.